

TCXO Specification Model ML602

CONNOR WINFIELD



2111 Comprehensive Drive
Aurora, Illinois 60505
Phone: 630-851-4722
Fax: 630-851-5040
www.conwin.com

US Headquarters:
630-851-4722
European Headquarters:
+353-61-472221

Description:

The Connor-Winfield ML602 is a surface mount 5x3.2mm, 3.3V, LVCMOS Temperature Compensated Crystal Oscillator (TCXO) designed for application compliance to Telcordia Stratum 3, ITU-T G.813 Option 2, and ITU-T G.8262 Option 2.



Features:

- 3.3 Vdc Operation
- Frequency Stability: ± 0.14 ppm
- Temperature Range: -40 to 85°C
- LVCMOS Output
- Ceramic Surface Mount Package
- Tape and Reel Packaging
- RoHS Compliant / Pb Free

Absolute Maximum Ratings

Parameter	Minimum	Nominal	Maximum	Units	Notes
Storage Temperature	-55	-	85	°C	
Supply Voltage (Vcc)	-0.5	-	6.0	Vdc	
Input Voltage	-0.5	-	Vcc+0.5		

Operating Specifications

Parameter	Minimum	Nominal	Maximum	Units	Notes
Nominal Frequency (Fo)	-	10, 20, and 24.576	-	MHz	
Frequency Calibration @ 25 °C	-1.0	-	1.0	ppm	1
Frequency Stability vs. Temperature	-140	-	140	ppb	2
Frequency vs. Load Stability	-50	-	50	ppb	$\pm 5\%$
Frequency vs. Voltage Stability	-50	-	50	ppb	$\pm 5\%$
Static Temperature Hysteresis	-	-	0.40	ppm	3
Short Term Allan Variance (1 second)	-	1.0E-10	-	RMS	
Constant Temperature Stability	-40	-	40	ppb	24 Hours
Aging 1st Year	-1.0	-	1.0	ppm	
Total Tolerance	-4.6	-	4.6	ppm	
Operating Temperature Range:	-40	-	85	°C	
Supply Voltage (Vcc)	3.135	3.3	3.465	Vdc	$\pm 5\%$
Supply Current (Icc)	-	-	6	mA	
Period Jitter	-	3	5	ps rms	
Integrated Phase Jitter	-	0.5	1.0	ps rms	4
SSB Phase Noise for Fo=20.0MHz					
@ 10 Hz offset	-	-90	-	dBc/Hz	
@ 100 Hz offset	-	-113	-	dBc/Hz	
@ 1 KHz offset	-	-135	-	dBc/Hz	
@ 10 KHz offset	-	-150	-	dBc/Hz	
@ 100 KHz offset	-	-150	-	dBc/Hz	
Start-up Time	-	-	10	ms	

LVCMOS Output Characteristics

Parameter	Minimum	Nominal	Maximum	Units	Notes
Load	-	15	-	pF	
Voltage (High) (Voh)	90%Vcc	-	-	Vdc	
(Low) (Vol)	-	-	10%Vcc	Vdc	
Duty Cycle at 50% of Vcc	45	50	55	%	
Rise / Fall Time 10% to 90%	-	4	8	ns	

Package Characteristics

Package Hermetically sealed crystal mounted on a ceramic package

Environmental Characteristics

Vibration: Vibration per Mil Std 883E Method 2007.3 Test Condition A
Shock: Mechanical Shock per Mil Std 883E Method 2002.4 Test Condition B.
Soldering Process: RoHS compliant lead free. See soldering profile on page 2.

Ordering Information

ML602-010.0M, ML602-020.0M, ML602-024.576M

Notes:

1. Frequency referenced to Fo. @ 25°C. Specification at time of shipment after 48 hours operation
2. Frequency stability vs. change in temperature. $[\pm(F_{max} - F_{min})/2.F_0]$.
3. Frequency change after reciprocal temperature ramped over the operating range. Frequency measured before and after at 25°C.
4. Bandwidth = 12KHz to Fo/2 MHz.



Bulletin **Tx418**
Page **1 of 3**
Revision **00**
Date **10 Feb 2015**



Package Layout

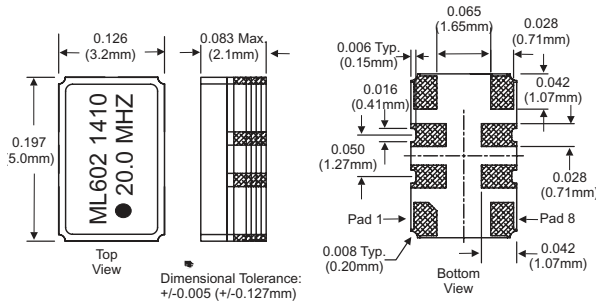

Suggested Pad Layout

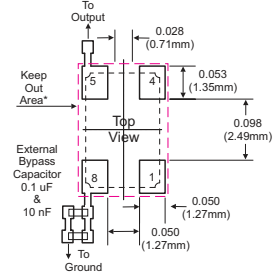

* Do not route any traces in the keep out area. It is recommended the next layer under the keep out area is to be ground plane.

ML602-024.576M Package Layout

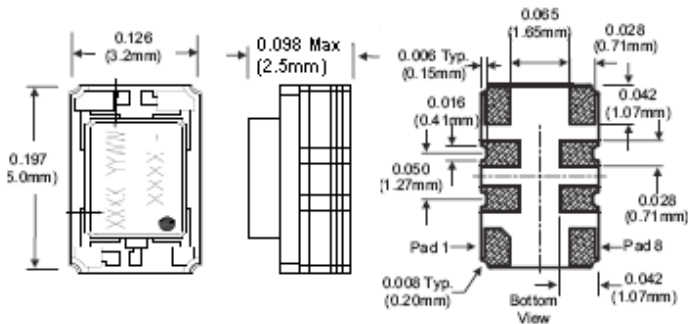

Pad Connections

- 1: N/C
- 2: Do Not Connect
- 3: Do Not Connect
- 4: Ground
- 5: Output
- 6: Do Not Connect
- 7: Do Not Connect
- 8: Supply Voltage (Vcc)

Typical Phase Noise

ML602-020.0M Typical Phase Noise (dBc/Hz)

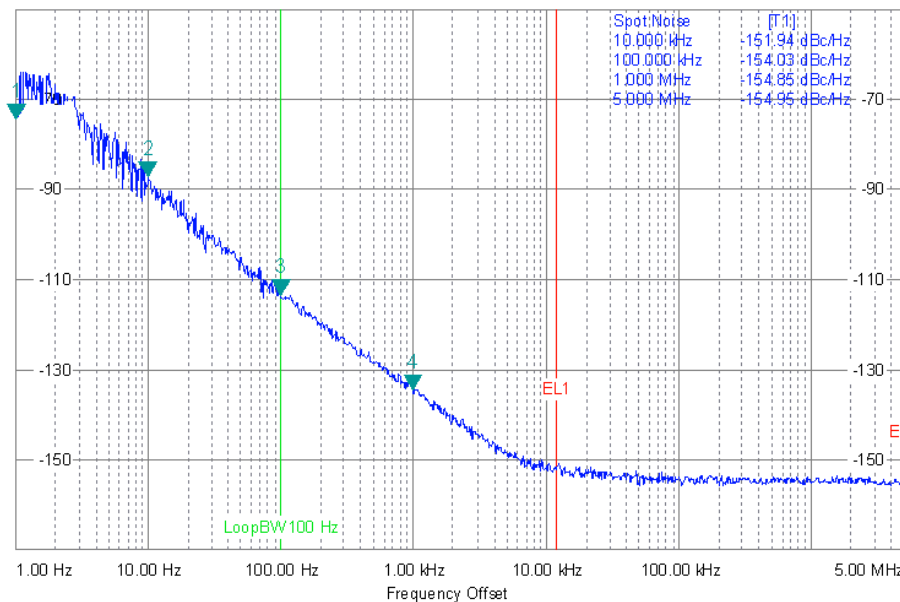



Design Recommendations

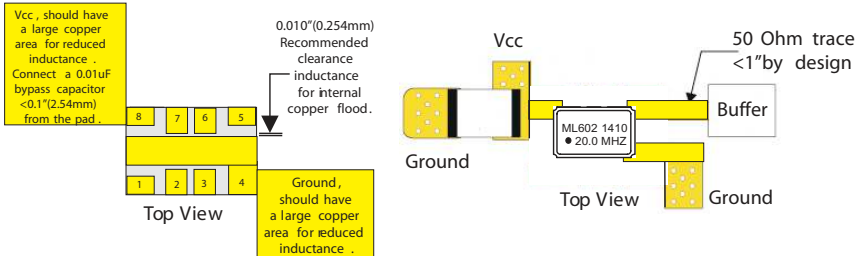

Attention: To achieve optimal frequency stability, and in some cases to meet the specification stated on this data sheet, it is required that the circuit connected to this TCXO output must have the equivalent input capacitance that is specified by the nominal load capacitance. Deviations from the nominal load capacitance will have a graduated effect on the stability of approximately 20 ppb per pF load difference.

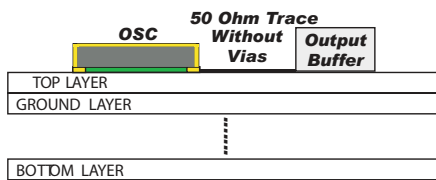

Test Circuit

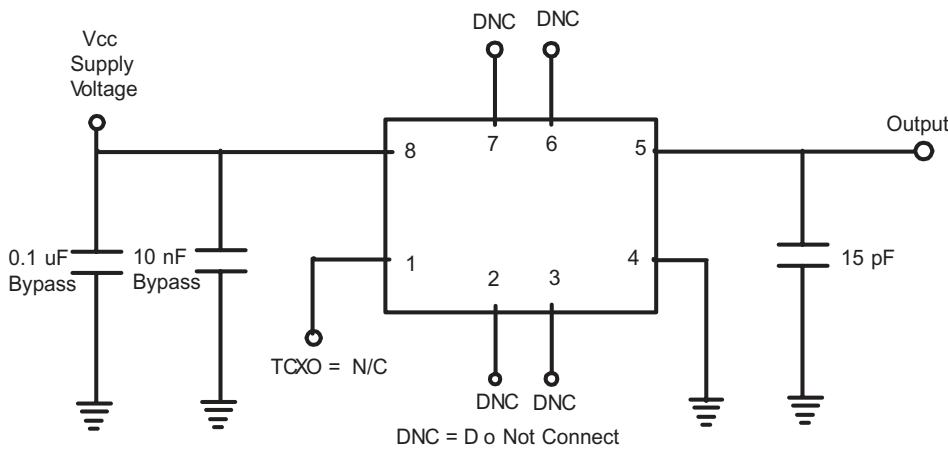

Output Waveform

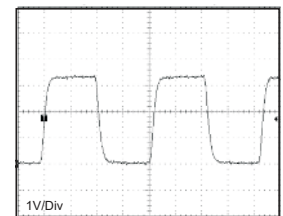

Tape and Reel Dimensions

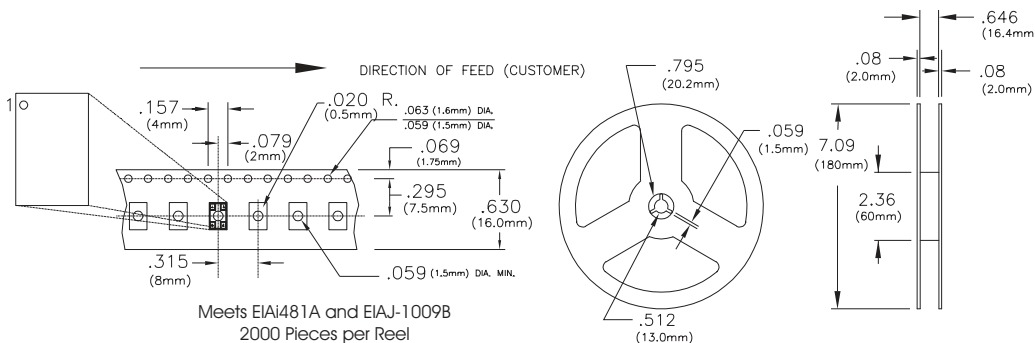

Solder Profile

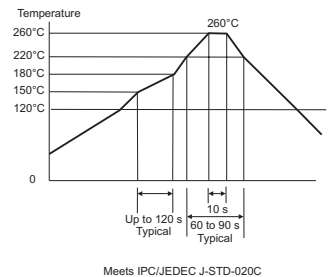

Bulletin	Tx418
Page	3 of 3
Revision	00
Date	10 Feb 2015