

DS125BR401A Low-Power 12 Gbps 4-Lane Linear Repeater With Equalization

1 Features

- Low 65-mW/Channel (Typ) Power Consumption, With Option to Power Down Unused Channels
- Linear Equalization allows for Link Training in PCIe and SAS
- Supports Out-of-Band (OOB) Signaling
- Advanced Signal Conditioning B-Side I/O
 - Receive CTLE up to 24 dB at 6 GHz
 - Transmit (Tx) DE > 10 dB
 - Tx Output Voltage: 700 mV to 1400 mV
- Advanced Signal Conditioning A-Side I/O
 - Receive CTLE up to 10 dB at 6 GHz
 - Linear output drive
 - Output voltage range over 1200mV
 Programmable via Terminal Selection, EEPROM, or SMBus Interface
- Single Supply Voltage: 2.5 V or 3.3 V
- -40°C to 85°C Operating Temperature Range
- 4 kV HBM ESD Rating
- Flow-Thru Layout in 10mmx5.5mm 54-Terminal Leadless WQFN Package

2 Applications

- SAS/SATA
- PCI Express
- Other Proprietary Interfaces up to 12 Gbps

3 Description

The DS125BR401A is an extremely low-power high-performance repeater/redriver designed to support four lanes carrying high speed interface up to 12 Gbps. The B-Side receiver's continuous time linear equalizers (CTLE) provide high frequency boost of up to +24 dB at 6 GHz (12 Gbps) and are capable of opening an input eye that is completely closed due to inter symbol interference (ISI) induced by interconnect medium such as backplane traces or twinaxial copper cables. The programmable equalization allows maximum flexibility in the physical placement within the interconnect channel. The A-Side channel has a 10 dB linear equalizer and linear output driver.

The A-Side channel has a settable 3-10 dB linear equalizer coupled to a linear output driver. When operating in SAS-3 and PCIe Gen-3 applications the DS125BR401A preserves transmit signal characteristics allowing the host controller and the end point to negotiate transmit equalizer coefficients. This transparency to the link training protocol aides system level interoperability and minimum latency.

The programmable settings can be applied easily via Terminals, software (SMBus or I2C), or loaded via an external EEPROM. In EEPROM mode, the configuration information is automatically loaded on power up, which eliminates the need for an external microprocessor or software driver.

Device Information

| ORDER NUMBER | PACKAGE | BODY SIZE |
|----------------|-----------|----------------|
| DS125BR401ANJY | WQFN (48) | 10 mm x 5.5 mm |

SAS-3 Application

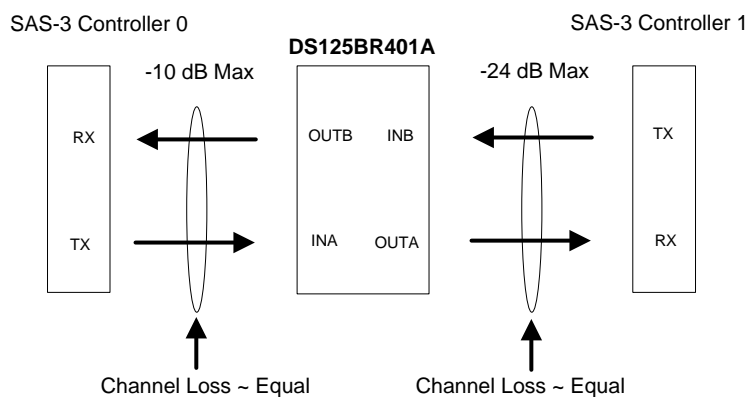

Table of Contents

| | | | |
|---|-----------|--|-----------|
| 1 Features | 1 | 7.3 Feature Description | 14 |
| 2 Applications | 1 | 7.4 Device Functional Modes | 14 |
| 3 Description | 1 | 7.5 Signal Conditioning Settings | 16 |
| 4 Revision History | 2 | 7.6 Programming | 18 |
| 5 Terminal Configuration and Functions | 3 | 7.7 Register Maps | 25 |
| 6 Specifications | 6 | 8 Applications and Implementation | 38 |
| 6.1 Absolute Maximum Ratings | 6 | 8.1 Application Information | 38 |
| 6.2 Handling Ratings | 6 | 8.2 Typical Application | 39 |
| 6.3 Recommended Operating Conditions | 6 | 9 Power Supply Recommendations | 42 |
| 6.4 Thermal Information | 6 | 10 Layout | 43 |
| 6.5 Electrical Characteristics | 6 | 10.1 Layout Guidelines | 43 |
| 6.6 Electrical Characteristics — Serial Management Bus Interface | 10 | 10.2 Layout Example | 43 |
| 6.7 Timing Requirements Serial Bus Interface | 10 | 11 Device and Documentation Support | 44 |
| 6.8 Typical Characteristics | 12 | 11.1 Trademarks | 44 |
| 7 Detailed Description | 13 | 11.2 Electrostatic Discharge Caution | 44 |
| 7.1 Overview | 13 | 11.3 Glossary | 44 |
| 7.2 Functional Block Diagram | 13 | 12 Mechanical, Packaging, and Orderable Information | 44 |

4 Revision History

Changes from Original (September 2013) to Revision A

Page

- | | |
|---|----------|
| • Changed from preview to production data document. | 1 |
| • Changed to new TI datasheet standard: added Handling Ratings table and Device and Documentation section. | 1 |

5 Terminal Configuration and Functions

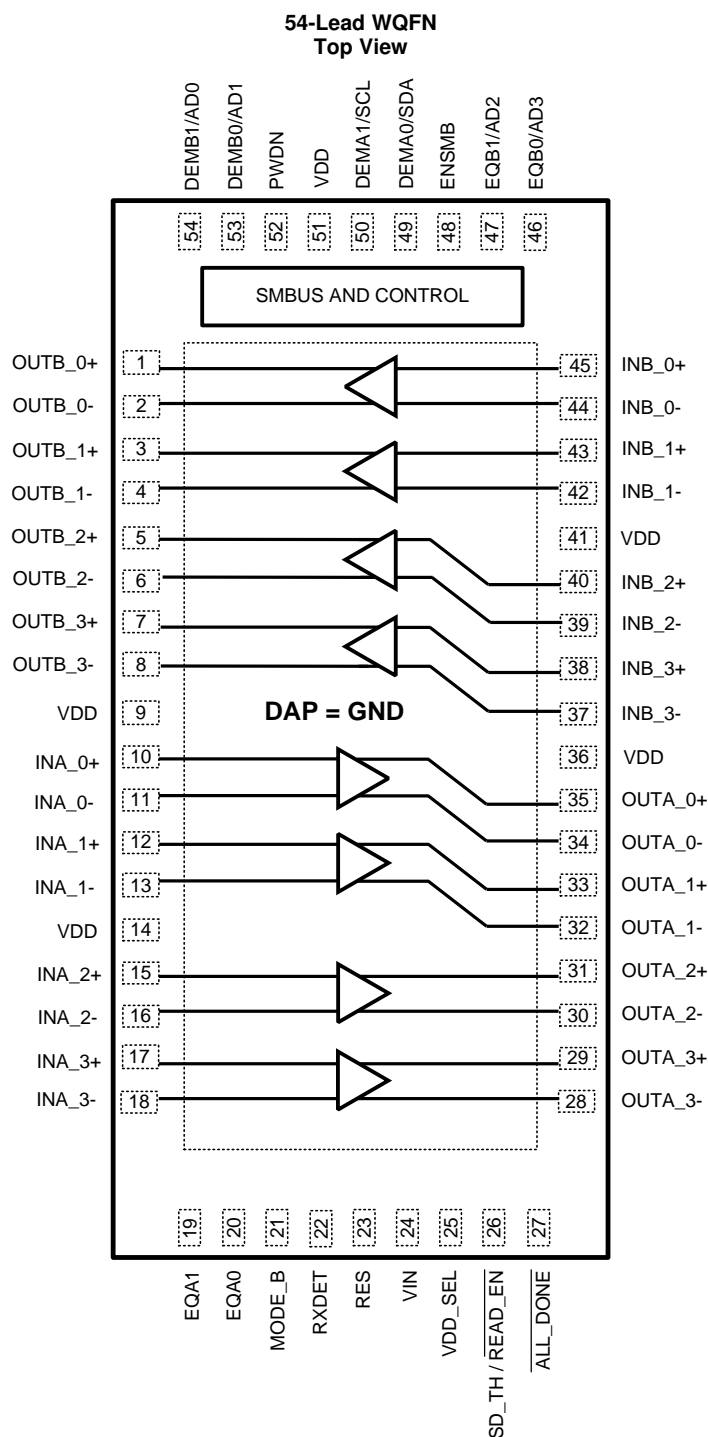

NOTE: Above 54-lead WQFN graphic is a TOP VIEW, looking down through the package.

Terminal Functions⁽¹⁾

| TERMINAL NAME | TERMINAL NUMBER | I/O, TYPE | TERMINAL DESCRIPTION |
|---|----------------------------------|-----------------------------|---|
| DIFFERENTIAL HIGH SPEED I/O | | | |
| INB_0+, INB_0-, INB_1+, INB_1-, INB_2+, INB_2-, INB_3+, INB_3- | 45, 44, 43, 42 40, 39, 38, 37 | I | Inverting and non-inverting CML differential inputs to the equalizer. On-chip 50Ω termination resistor connects INB_n+ to VDD and INB_n- to VDD when enabled. AC coupling required on high-speed I/O |
| OUTB_0+, OUTB_0-, OUTB_1+, OUTB_1-, OUTB_2+, OUTB_2-, OUTB_3+, OUTB_3- | 1, 2, 3, 4 5, 6, 7, 8 | O | Inverting and non-inverting 50Ω driver outputs with de-emphasis. Compatible with AC coupled CML inputs. AC coupling required on high-speed I/O |
| INA_0+, INA_0-, INA_1+, INA_1-, INA_2+, INA_2-, INA_3+, INA_3- | 10, 11, 12, 13 15, 16, 17, 18 | I | Inverting and non-inverting CML differential inputs to the equalizer. On-chip 50Ω termination resistor connects INA_n+ to VDD and INA_n- to VDD when enabled. AC coupling required on high-speed I/O |
| OUTA_0+, OUTA_0-, OUTA_1+, OUTA_1-, OUTA_2+, OUTA_2-, OUTA_3+, OUTA_3- | 35, 34, 33, 32 31, 30, 29, 28 | O | Inverting and non-inverting 50Ω driver outputs. Compatible with AC coupled CML inputs. AC coupling required on high-speed I/O |
| CONTROL TERMINALS — SHARED (LVCMOS) | | | |
| ENSMB | 48 | I, LVCMOS | System Management Bus (SMBus) enable Terminal Tie 1kΩ to VDD = Register Access SMBus Slave mode FLOAT = Read External EEPROM (Master SMBUS Mode) Tie 1kΩ to GND = Terminal Mode |
| ENSMB = 1 (SMBus MODE) | | | |
| SCL | 50 | I, LVCMOS, O, OPEN Drain | ENSMB Master or Slave mode SMBus clock input Terminal is enabled (slave mode). Clock output when loading EEPROM configuration (master mode). |
| SDA | 49 | I, LVCMOS, O, OPEN Drain | ENSMB Master or Slave mode The SMBus bidirectional SDA Terminal is enabled. Data input or open drain (pull-down only) output. |
| AD0-AD3 | 54, 53, 47, 46 | I, LVCMOS | ENSMB Master or Slave mode SMBus Slave Address Inputs. In SMBus mode, these Terminals are the user set SMBus slave address inputs. |
| READ_EN | 26 | I, LVCMOS | When using an External EEPROM, a logic low on this terminal starts the load from the external EEPROM |
| ENSMB = 0 (TERMINAL MODE) | | | |
| EQA0, EQA1 EQB0, EQB1 | 20, 19 46, 47 | I, 4-LEVEL, LVCMOS | EQA[1:0] and EQB[1:0] control the level of equalization of the A/B directions. The Terminals are defined as EQx[1:0] only when ENSMB is de-asserted (low). Each of the 4 A/B channels have the same level unless controlled by the SMBus control registers. When ENSMB goes high the SMBus registers provide independent control of each lane. The EQB[1:0] Terminals are converted to SMBus AD2, AD3 inputs. See Table 5 . |
| DEMB0, DEMB1 | 53, 54 | I, 4-LEVEL, LVCMOS | DEMB[1:0] controls the level of de-emphasis of CHB outputs. The Terminals are defined as DEMB[1:0] only when ENSMB is de-asserted (low). Each of the 4 B channels have the same level unless controlled by the SMBus control registers. When ENSMB goes high the SMBus registers provide independent control of each lane. The DEMB[1:0] Terminals are converted to AD0, AD1 inputs. See Table 7 . |
| MODE_B | 21 | I, 4-LEVEL, LVCMOS | MODE_B control Terminal selects operating modes for the INB-OUTB Channels. Tie 1kΩ to GND = GEN 1,2 and SAS 1,2 Float = Auto Mode Select (for PCIe) Tie 20kΩ to GND = SAS-3 and GEN-3 without De-emphasis Tie 1kΩ to VDD = SAS-3 and GEN-3 with De-emphasis See Table 4 . |

- (1) LVCMOS inputs without the "Float" conditions must be driven to a logic low or high at all times or operation is not ensured. Input edge rate for LVCMOS/FLOAT inputs must be faster than 50 ns from 10–90%.
For 3.3V mode operation, VIN Terminal input = 3.3V and the logic "1" reference for the 4-level input is 3.3V.
For 2.5V mode operation, VDD Terminal output = 2.5V and the logic "1" reference for the 4-level input is 2.5V.

Terminal Functions⁽¹⁾ (continued)

| TERMINAL NAME | TERMINAL NUMBER | I/O, TYPE | TERMINAL DESCRIPTION |
|--|------------------|---------------------|--|
| DEMA0, DEMA1 | 49, 50 | I, 4-LEVEL, LVC MOS | DEMA[1:0] controls the CHA output amplitude. The Terminals are defined as DEMA[1:0] only when ENSMB is de-asserted (low). Each of the 4 A channels have the same level unless controlled by the SMBus control registers. When ENSMB goes high the SMBus registers provide independent control of each lane and the DEMA[1:0] Terminals are converted to SCL and SDA. See Table 7 . |
| SD_TH | 26 | I, 4-LEVEL, LVC MOS | Controls the internal Signal Detect Threshold on the INB-OUTB Channels. For CHB, the signal detect is used to bring the output into and out of IDLE. This allows the OOB signaling to pass with minimal distortion. See Table 3 . |
| CONTROL TERMINALS — BOTH TERMINAL AND SMBus MODES (LVC MOS) | | | |
| RXDET | 22 | I, 4-LEVEL, LVC MOS | The RXDET Terminal controls the receiver detect function. Depending on the input level, a 50Ω or >50KΩ termination to the power rail is enabled. In SAS/SATA system RXDET should be set to a Logic "1" state to keep the termination always enabled. See Table 2 . |
| RES | 23 | I, 4-LEVEL, LVC MOS | Reserved: This input must be left Floating. |
| VDD_SEL | 25 | I, FLOAT | Controls the internal regulator Float = 2.5V mode Tie GND = 3.3V mode |
| PWDN | 52 | I, LVC MOS | Tie High = Low power - power down Tie GND = Normal Operation See Table 2 . |
| ALL_DONE | 27 | O, LVC MOS | Valid Register Load Status Output HIGH = External EEPROM load failed or incomplete LOW = External EEPROM load passed |
| POWER | | | |
| VIN | 24 | Power | In 3.3V mode, feed 3.3V to VIN In 2.5V mode, leave floating. |
| VDD | 9, 14,36, 41, 51 | Power | Power supply Terminals CML/analog 2.5V mode, connect to 2.5V 3.3V mode, connect 0.1 μF cap to each VDD Terminal and GND |
| GND | DAP | Power | Ground pad (DAP - die attach pad). |

6 Specifications

6.1 Absolute Maximum Ratings⁽¹⁾

| | MIN | MAX | UNIT |
|------------------------------|--------------------|-------|------|
| Supply Voltage (VDD - 2.5V) | -0.5 | +2.75 | V |
| Supply Voltage (VIN - 3.3V) | -0.5 | +4.0 | V |
| LVC MOS Input/Output Voltage | -0.5 | +4.0 | V |
| CML Input Voltage | -0.5V to (VDD+0.5) | | |
| CML Input Current | -30 | +30 | mA |

- (1) “Absolute Maximum Ratings” indicate limits beyond which damage to the device may occur, including inoperability and degradation of device reliability and/or performance. Functional operation of the device and/or non-degradation at the Absolute Maximum Ratings or other conditions beyond those indicated in the Recommended Operating Conditions is not implied. The Recommended Operating Conditions indicate conditions at which the device is functional and the device should not be operated beyond such conditions. Absolute Maximum Numbers are ensured for a junction temperature range of -40°C to +125°C. Models are validated to Maximum Operating Voltages only.

6.2 Handling Ratings

| | | MIN | MAX | UNIT |
|---------------------|--|-----|-----|------|
| ESD _{HBM} | HBM, STD - JESD22-A114F | | 4 | kV |
| ESD _{CDM} | CDM, STD - JESD22-C101-D | | 1 | kV |
| T _{stg} | Storage Temperature Range | -40 | 125 | °C |
| T _{solder} | Lead Temperature Range Soldering (4 sec.) ⁽¹⁾ | | 260 | °C |

- (1) For soldering specifications: See application note [SNOA549](#).

6.3 Recommended Operating Conditions

| | MIN | TYP | MAX | UNIT |
|--|-------|-----|-------|-------|
| Supply Voltage (2.5V mode) | 2.375 | 2.5 | 2.625 | V |
| Supply Voltage (3.3V mode) | 3.0 | 3.3 | 3.6 | V |
| Ambient Temperature | -40 | 25 | +85 | °C |
| SMBus (SDA, SCL) | | | 3.6 | V |
| Supply Noise up to 50 MHz ⁽¹⁾ | | | 100 | mVp-p |

- (1) Allowed supply noise (mVp-p sine wave) under typical conditions.

6.4 Thermal Information

| THERMAL METRIC ⁽¹⁾ | | DS125BR401A | UNIT |
|-------------------------------|--|--------------|------|
| | | WQFN | |
| | | 54 TERMINALS | |
| R _{θJA} | Junction-to-ambient thermal resistance | 26.6 | °C/W |
| R _{θJctop} | Junction-to-case (top) thermal resistance | 10.8 | |
| R _{θJB} | Junction-to-board thermal resistance | 4.4 | |
| Ψ _{JT} | Junction-to-top characterization parameter | 0.2 | |
| Ψ _{JB} | Junction-to-board characterization parameter | 4.3 | |
| R _{θJcbot} | Junction-to-case (bottom) thermal resistance | 1.5 | |

- (1) For more information about traditional and new thermal metrics, see the *IC Package Thermal Metrics* application report, [SPRA953](#).

6.5 Electrical Characteristics

| PARAMETER | | TEST CONDITIONS | MIN | TYP | MAX | UNIT |
|-----------------|--------------------------------|--|-----|-----|-----|------|
| POWER | | | | | | |
| I _{DD} | Current Consumption | DEM0 = Float, ,DEM1 = Float EQ = 0, VOD = 0.8VP-P, RXDET = 1, PWDN = 0 | | 200 | 280 | mA |
| | Power Down Current Consumption | PWDN = 1 | | 14 | 27 | mA |

Electrical Characteristics (continued)

| PARAMETER | | TEST CONDITIONS | MIN | TYP | MAX | UNIT |
|---|--|---|-------|-----|-----------------|-------|
| V _{DD} | Integrated LDO Regulator | V _{IN} = 3.0 - 3.6 V | 2.375 | 2.5 | 2.625 | V |
| LVC MOS / LV TTL DC SPECIFICATIONS | | | | | | |
| V _{ih25} | High Level Input Voltage | 2.5 V Supply Mode | 1.7 | | V _{DD} | V |
| V _{ih33} | High Level Input Voltage | 3.3 V Supply Mode | 1.7 | | V _{IN} | V |
| V _{il} | Low Level Input Voltage | | 0 | | 0.7 | V |
| V _{oh} | High Level Output Voltage (ALL_DONE Terminal) | I _{oh} = -4mA | 2.0 | | | V |
| V _{ol} | Low Level Output Voltage (ALL_DONE Terminal) | I _{ol} = 4mA | | | 0.4 | V |
| I _{ih} | Input High Current (PWDN Terminal) | V _{IN} = 3.6 V, LVC MOS = 3.6 V | -15 | | +15 | µA |
| I _{il} | Input Low Current (PWDN Terminal) | V _{IN} = 3.6 V, LVC MOS = 0 V | -15 | | +15 | µA |
| 4-LEVEL INPUT DC SPECIFICATIONS | | | | | | |
| I _{ih} | Input High Current with internal resistors (4-level input Terminal) | V _{IN} = 3.6 V, LVC MOS = 3.6 V | +20 | | +150 | µA |
| I _{il} | Input Low Current with internal resistors (4-level input Terminal) | V _{IN} = 3.6 V, LVC MOS = 0 V | -160 | | -40 | µA |
| V _{th} | Threshold 0 / R | V _{DD} = 2.5V (2.5V supply mode) Internal LDO Disabled See Table 1 for details | | | 0.45 | V |
| | Threshold R / Float | | | | 1.2 | |
| | Threshold Float / 1 | | | | 2 | |
| | Threshold 0 / R | V _{IN} = 3.3V (3.3V supply mode) Internal LDO Enabled See Table 1 for details. | | | 0.6 | V |
| | Threshold R / Float | | | | 1.6 | |
| | Threshold Float / 1 | | | | 2.6 | |
| CML RECEIVER INPUTS (IN_{n+}, IN_{n-}) | | | | | | |
| RL _{RX-diff} | RX Differential return loss | SDD11 10 MHz | | | -19 | dB |
| | | SDD11 2 GHz | | | -14 | |
| | | SDD11 6-11.1 GHz | | | -8 | |
| RL _{RX-cm} | RX Common mode return loss | 0.05 - 5 GHz | | | -10 | dB |
| Z _{RX-dc} | RX DC common mode impedance | Tested at V _{DD} = 2.5 V | 40 | 50 | 60 | Ω |
| Z _{RX-diff-dc} | RX DC differential mode impedance | Tested at V _{DD} = 2.5 V | 80 | 100 | 120 | Ω |
| V _{RX-signal-det-diff-pp} | Signal detect assert level for active data signal | SD_TH = F (float), 0101 pattern at 12 Gbps | | | 50 | mVp-p |
| V _{RX-idle-det-diff-pp} | Signal detect de-assert level for electrical idle | SD_TH = F (float), 0101 pattern at 12 Gbps | | | 37 | mVp-p |
| HIGH SPEED OUTPUTS | | | | | | |
| T _{TX-RISE-FALL} | Transmitter rise/fall time ⁽¹⁾ | 20% to 80% of differential output voltage | | | 40 | ps |
| T _{RF-MISMATCH} | Transmitter rise/fall mismatch | 20% to 80% of differential output voltage | | | 0.01 | UI |
| RL _{TX-DIFF} | TX Differential return loss | SDD22 10 MHz - 2 GHz | | | -15 | dB |
| | | SDD22 5.5 GHz | | | -12 | |
| | | SDD22 11.1 GHz | | | -10 | |
| RL _{TX-CM} | TX Common mode return loss | 0.05 - 5 GHz | | | -10 | dB |
| Z _{TX-DIFF-DC} | DC differential TX impedance | | | | 100 | Ω |
| I _{TX-SHORT} | Transmitter short circuit current limit | Total current, output shorted to V _{DD} or GND | | | 20 | mA |
| V _{TX-CM-DC-ACTIVE-IDLE-DELTA} | Absolute delta of DC common mode voltage during L0 and electrical idle | | | | 100 | mV |

(1) Rise / Fall time measurements will on A-Channels will vary based on EQ setting, Input Amplitude, and input edge rate.

Electrical Characteristics (continued)

| PARAMETER | | TEST CONDITIONS | MIN | TYP | MAX | UNIT |
|--|--|---|-----|------|------|-------|
| $V_{TX-CM-DC-LINE-DELTA}$ | Absolute delta of DC common mode voltage between TX+ and TX- | | | | 25 | mV |
| HIGH SPEED OUTPUTS (A-CHANNELS) | | | | | | |
| $V_{TXA-diff1-pp}$ | Output Voltage Differential Swing | Differential measurement with OUTA _{n+} and OUTA _{n-} , AC-Coupled and terminated by 50Ω to GND, Inputs AC-Coupled, VID = 600 mVp-p, VOD = 001'b (800mV) | 375 | 465 | 600 | mVp-p |
| $V_{TXA-diff2-pp}$ | Output Voltage Differential Swing | Differential measurement with OUTA _{n+} and OUTA _{n-} , AC-Coupled and terminated by 50Ω to GND, Inputs AC-Coupled, VID = 1000 mVp-p, VOD = 001'b (800mV) | 550 | 675 | 825 | mVp-p |
| $V_{TXA-diff3-pp}$ | Output Voltage Differential Swing | Differential measurement with OUTA _{n+} and OUTA _{n-} , AC-Coupled and terminated by 50Ω to GND, Inputs AC-Coupled, VID = 600 mVp-p, DEMA[1:0] = 10, VOD = 1300mV | 475 | 600 | 750 | Vp-p |
| $V_{TXA-diff4-pp}$ | Output Voltage Differential Swing | Differential measurement with OUTA _{n+} and OUTA _{n-} , AC-Coupled and terminated by 50Ω to GND, Inputs AC-Coupled, VID = 1000 mVp-p, VOD = 110'b (1300mV) | 775 | 915 | 1125 | Vp-p |
| $T_{TXA-IDLE-DATA}$ | Time to transition to valid differential signal after idle | VID = 1.0 Vp-p, 3 Gbps | | 0.04 | | ns |
| $T_{TXA-DATA-IDLE}$ | Time to transition to idle after differential signal | VID = 1.0 Vp-p, 3 Gbps | | 0.70 | | ns |
| T_{PDEQA} | Differential propagation delay - Channel A | EQ = Level 1 to Level 4 | | 80 | | ps |
| HIGH SPEED OUTPUTS (B-CHANNELS) | | | | | | |
| $V_{TXB-diff1-pp}$ | Output Voltage Differential Swing | Differential measurement with OUTB _{n+} and OUTB _{n-} , AC-Coupled and terminated by 50Ω to GND, Inputs AC-Coupled, VID = 1.0 Vp-p, MODE_B = 1, DEMB1 = 0, DEMB0 = 1 ⁽²⁾ | 0.8 | 1.0 | 1.2 | Vp-p |
| $V_{TXB-diff2-pp}$ | Output Voltage Differential Swing | Differential measurement with OUTB _{n+} and OUTB _{n-} , AC-Coupled and terminated by 50Ω to GND, Inputs AC-Coupled, VID = 1.0 Vp-p, MODE_B = 0, DEMB1 = 0, DEMB0 = R | 670 | 820 | 930 | mVp-p |
| $V_{TXB-diff3-pp}$ | Output Voltage Differential Swing | Differential measurement with OUTB _{n+} and OUTB _{n-} , AC-Coupled and terminated by 50Ω to GND, Inputs AC-Coupled, VID = 1.0 Vp-p, MODE_B = 0, DEMB1 = R, DEMB0 = FLOAT | 950 | 1140 | 1250 | mVp-p |

(2) In SAS-3 and PCIe GEN3 mode, the output VOD level is not fixed. It will be adjusted automatically based on the VID input amplitude level. The output VOD level set by DEMA/B[1:0] in this mode BOUTn is dependent on the VID level and the frequency content. The DS125BR401A repeater is designed to be transparent in this mode, so the TX-FIR (de-emphasis) is passed to the RX to support the handshake negotiation link training.

Electrical Characteristics (continued)

| PARAMETER | | TEST CONDITIONS | MIN | TYP | MAX | UNIT |
|--|--|--|-----|------|-----|------|
| $V_{\text{TXB-de-ratio_3.5}}$ | TX de-emphasis ratio | VOD = 1.0 Vp-p, DEM0 = 0, DEM1 = R, MODE_B = 0 OUTB_n only Gen 1 & 2 mode | | -3.5 | | dB |
| $V_{\text{TXB-de-ratio_6}}$ | TX de-emphasis ratio | VOD = 1.0 Vp-p, DEM0 = R, DEM1 = R, MODE_B = 0 OUTB_n only in Gen 1 & 2 mode | | -6 | | dB |
| $T_{\text{TXB-IDLE-DATA}}$ | Time to transition to valid differential signal after idle | VID = 1.0 Vp-p, 3 Gbps | | 3.5 | | ns |
| $T_{\text{TXB-DATA-IDLE}}$ | Time to transition to idle after differential signal | VID = 1.0 Vp-p, 3 Gbps | | 5.0 | | ns |
| T_{PDEQB} | Differential propagation delay - Channel B | EQ = 00 ⁽³⁾ | | 135 | | ps |
| EQUALIZATION (A-CHANNELS) | | | | | | |
| DJE1A | Residual deterministic jitter at 6 Gbps | 5" Differential Stripline, 5mil trace width, FR4, VID = 0.8 Vp-p, PRBS15, EQ = 01'h , VOD = 1.3V, DEM = 0 dB | | 0.06 | | UI |
| DJE3A | Residual deterministic jitter at 12 Gbps | 5" Differential Stripline, 5mil trace width, FR4, VID = 0.8 Vp-p, PRBS15, EQ = 01'h , VOD = 1.3V, DEM = 0 dB | | 0.12 | | UI |
| EQUALIZATION (B-CHANNELS) | | | | | | |
| DJE1B | Residual deterministic jitter at 12 Gbps | 30" Differential Stripline, 5mil trace width, FR4, VID = 0.6 Vp-p, PRBS15, EQ = 07'h , DEM = 0 dB | | 0.18 | | UI |
| DJE2B | Residual deterministic jitter at 12 Gbps | 5 meters 30 awg cable, VID = 0.6 Vp-p, PRBS15, EQ = 07'h , DEM = 0 dB | | 0.25 | | UI |
| DE-EMPHASIS (B-CHANNELS, GEN 1&2 MODE ONLY) | | | | | | |
| DJD1 | Residual deterministic jitter at 12 Gbps | Input Channel: 20" Differential Stripline, 5mil trace width, FR4, Output Channel: 10" Differential Stripline, 5mil trace width, FR4, VID = 0.6 Vp-p, PRBS15, EQ = 03'h, VOD = 1.0 Vp-p, DEMB = -3.5 dB | | 0.1 | | UI |

(3) Propagation Delay measurements will change slightly based on the level of EQ selected. EQ = 00 will result in the shortest propagation delays.

6.6 Electrical Characteristics — Serial Management Bus Interface

Over recommended operating supply and temperature ranges unless other specified.

| PARAMETER | | TEST CONDITIONS | MIN | TYP | MAX | UNIT |
|---|--|------------------------------------|-------|------|------|----------|
| SERIAL BUS INTERFACE DC SPECIFICATIONS | | | | | | |
| V_{IL} | Data, Clock Input Low Voltage | | | | 0.8 | V |
| V_{IH} | Data, Clock Input High Voltage | | 2.1 | | 3.6 | V |
| V_{OL} | Output Low Voltage | SDA or SCL, $I_{OL} = 1.25$ mA | 0 | | 0.36 | V |
| V_{DD} | Nominal Bus Voltage | | 2.375 | | 3.6 | V |
| $I_{IH-Terminal}$ | Input Leakage Per Device Terminal | | +20 | | +150 | μ A |
| $I_{IL-Terminal}$ | Input Leakage Per Device Terminal | | -160 | | -40 | μ A |
| C_I | Capacitance for SDA and SCL | See ⁽¹⁾⁽²⁾ | | < 5 | | pF |
| R_{TERM} | External Termination Resistance pull to $V_{DD} = 2.5V \pm 5\%$ OR $3.3V \pm 10\%$ | Pullup $V_{DD} = 3.3V^{(1)(2)(3)}$ | | 2000 | | Ω |
| | | Pullup $V_{DD} = 2.5V^{(1)(2)(3)}$ | | 1000 | | Ω |

(1) Recommended value.

(2) Recommended maximum capacitance load per bus segment is 400pF.

(3) Maximum termination voltage should be identical to the device supply voltage.

6.7 Timing Requirements Serial Bus Interface

| PARAMETER | | TEST CONDITIONS | MIN | TYP | MAX | UNIT |
|---|-------------------------|---|-----|-----|------|------|
| SERIAL BUS INTERFACE TIMING SPECIFICATIONS | | | | | | |
| FSMB | Bus Operating Frequency | ENSMB = V_{DD} (Slave Mode) | | | 400 | kHz |
| | | ENSMB = FLOAT (Master Mode) | 280 | 400 | 520 | kHz |
| t_{FALL} | SDA Fall Time | Read operation RPU = 4.7K, $C_b < 50$ pF | | 60 | | ns |
| t_{RISE} | SDA Rise Time | Read operation RPU = 4.7K, $C_b < 50$ pF | | 140 | | ns |
| t_F | Clock/Data Fall Time | See ⁽¹⁾ | | | 300 | ns |
| t_R | Clock/Data Rise Time | See ⁽¹⁾ | | | 1000 | ns |

(1) Compliant to SMBus 2.0 physical layer specification. See System Management Bus (SMBus) Specification Version 2.0, section 3.1.1 SMBus common AC specifications for details.

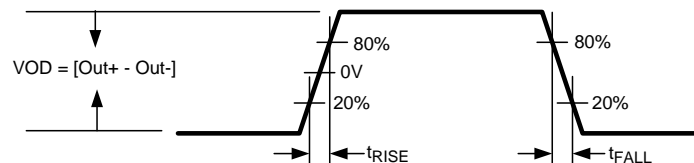

Figure 1. Output and Rise And Fall Transition Time

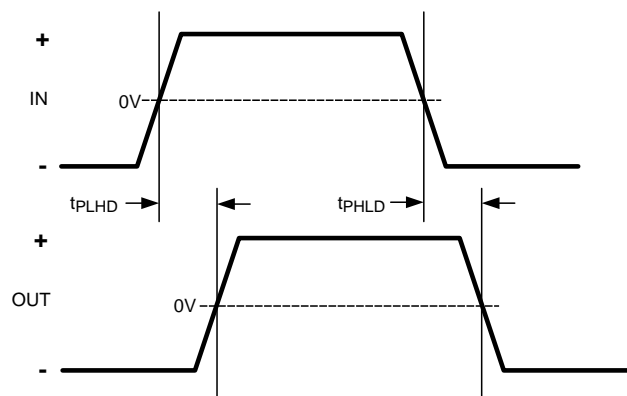

Figure 2. Propagation Delay Timing Diagram

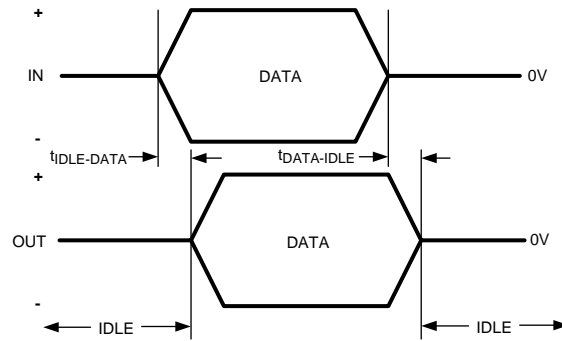

Figure 3. Transmit Idle-Data and Data-Idle Response Time

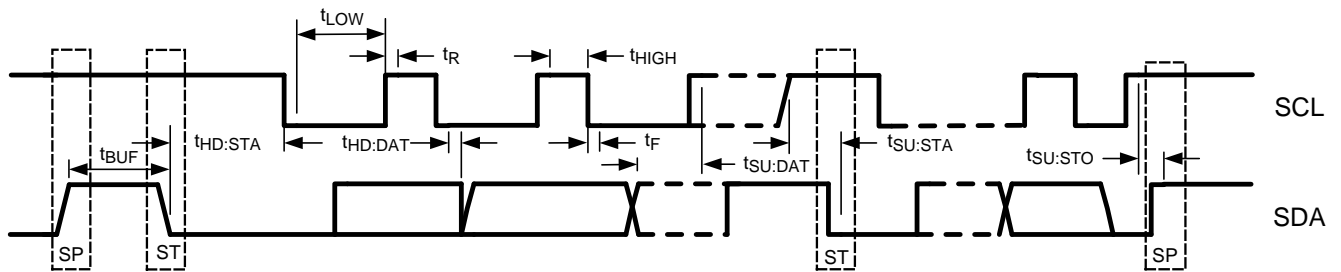

Figure 4. SMBus Timing Parameters

6.8 Typical Characteristics

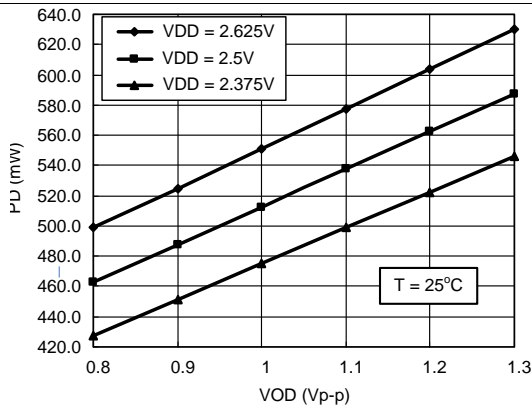

Figure 5. Typical Power Dissipation vs. Output Voltage Amplitude Setting

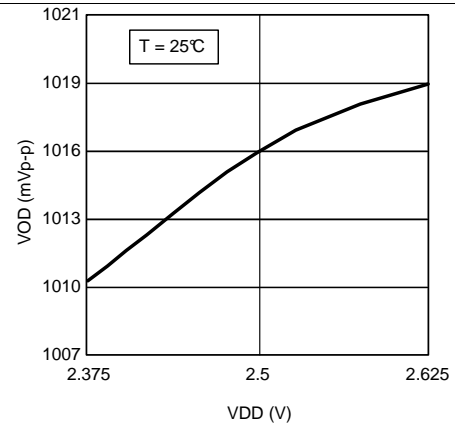

Figure 6. Channel-B Output Differential Voltage vs. VDD (VOD = 1000 mV setting)

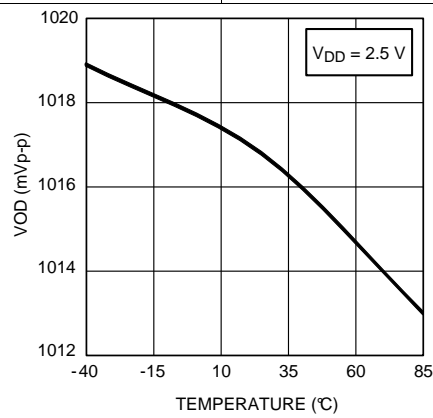

Figure 7. Channel-B Output Differential Voltage Vs. Temperature (VOD = 1000 mV setting)

7 Detailed Description

7.1 Overview

The DS125BR401A compensates for lossy FR-4 printed circuit board backplanes and balanced cables. The DS125BR401A operates in 3 modes: Terminal Control Mode (ENSMB = 0), SMBus Slave Mode (ENSMB = 1) and SMBus Master Mode (ENSMB = float) to load register information from external EEPROM; please refer to SMBus Master Mode for additional information.

7.2 Functional Block Diagram

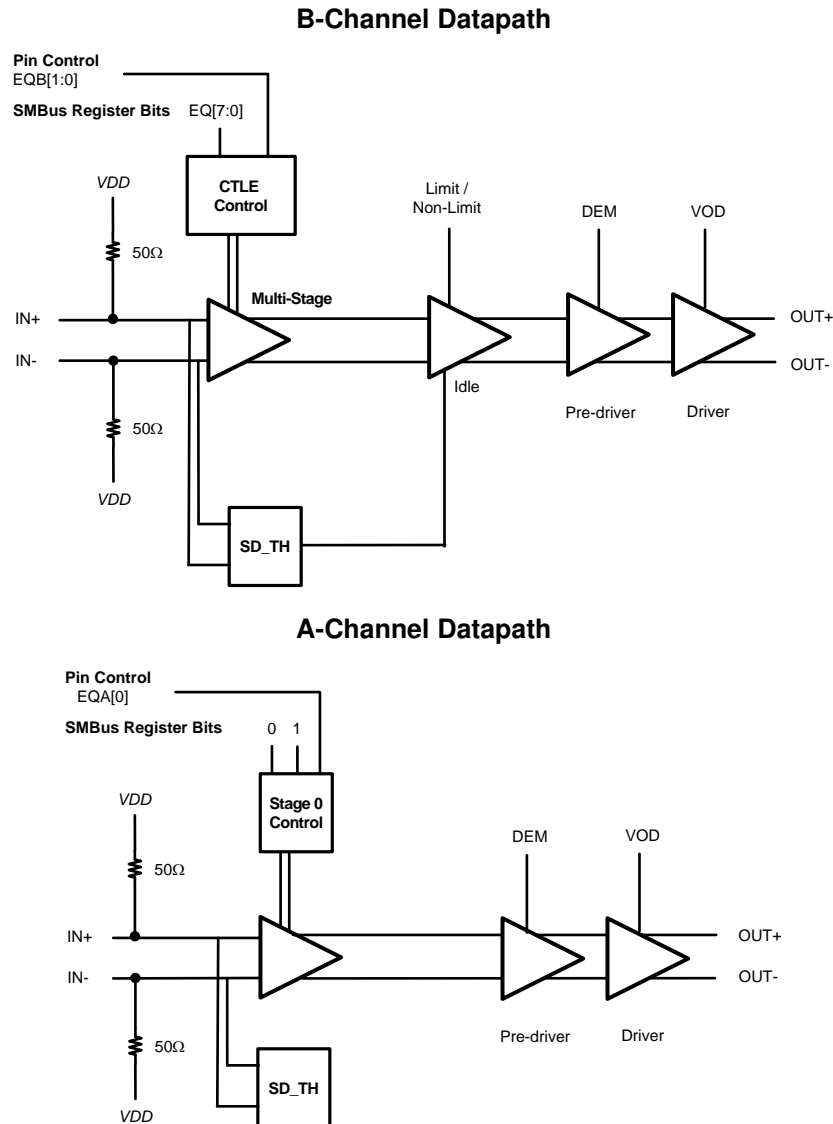

7.2.1 Functional Datapath Blocks

The Channel-B datapath is designed to handle higher levels of input attenuation and includes an output with a soft-limiting function to provide some transparency for Rx-Tx training in SAS-3 and other standards. The Channel-A datapath has less input equalization coupled with a linear driver. This combination has a high level of transparency, achieving greater drive distance in SAS-3 applications which utilize Rx-Tx training. The asymmetrical channel design follows the application diagram in .

Functional Block Diagram (continued)

The Channel-A and Channel-B data-paths are optimized to work as a transparent driver and a transparent receiver. The typical DS125BR401A system placement breaks a long transmission line into two pieces. This often leads to one short and one long piece, this unequal partition places different demands on A and B-Channels. To maximize channel extension with the DS125BR401A, connect the A-Channel Inputs to the channel segment with the lowest attenuation to the SAS-3 Tx.

7.3 Feature Description

The 4-level input Terminals utilize a resistor divider to help set the 4 valid levels and provide a wider range of control settings when ENSMB=0. There is an internal 30K pull-up and a 60K pull-down connected to the package Terminal. These resistors, together with the external resistor connection combine to achieve the desired voltage level. Using the 1K pull-up, 1K pull-down, no connect, and 20K pull-down provide the optimal voltage levels for each of the four input states.

Table 1. 4-Level Control Terminal Settings

| Level | Setting | 3.3V Mode | 2.5V Mode |
|-------|---------------------------------|---------------------------|---------------------------|
| 0 | Tie 1kΩ to GND | 0.10 V | 0.08 V |
| R | Tie 20kΩ to GND | $1/3 \times V_{IN}$ | $1/3 \times V_{DD}$ |
| Float | Float (leave Terminal open) | $2/3 \times V_{IN}$ | $2/3 \times V_{DD}$ |
| 1 | Tie 1kΩ to V_{IN} or V_{DD} | $V_{IN} - 0.05 \text{ V}$ | $V_{DD} - 0.04 \text{ V}$ |

Typical 4-Level Input Thresholds

- Level 1 - 2 = $0.2 \times V_{IN}$ or V_{DD}
- Level 2 - 3 = $0.5 \times V_{IN}$ or V_{DD}
- Level 3 - 4 = $0.8 \times V_{IN}$ or V_{DD}

In order to minimize the startup current associated with the integrated 2.5V regulator the 1K pull-up / pull-down resistors are recommended. If several 4 level inputs require the same setting, it is possible to combine two or more 1K resistors into a single lower value resistor. As an example; combining two inputs with a single 500 Ohm resistor is a good way to save board space.

7.4 Device Functional Modes

7.4.1 Terminal Control Mode:

When in Terminal mode (ENSMB = 0), equalization and de-emphasis can be selected via Terminal for each side independently. When de-emphasis is asserted VOD is automatically adjusted per [Table 7](#). For PCIe applications, the RXDET Terminals provides automatic and manual control for input termination (50Ω or >50KΩ). MODE_B setting is also Terminal controllable with Terminal selections (Gen 1/2, auto detect, and SAS-3 / PCIe Gen 3). The receiver electrical signal detect threshold is also adjustable via the SD_TH Terminal. For A-Side Channels this can only be used for status information, on B-Side Channels this threshold will determine when the output state, Mute if no signal is present or active with a valid input signal detected.

7.4.2 SMBus Mode:

When in SMBus mode (ENSMB = 1), the VOD (output amplitude), equalization, de-emphasis, and termination disable features are all programmable on a individual lane basis, instead of grouped by A or B as in the Terminal mode case. Upon assertion of ENSMB, the EQx and DEMx functions revert to register control immediately. The EQx and DEMx Terminals are converted to AD0-AD3 SMBus address inputs. The other external control Terminals (MODE_B, RXDET and SD_TH) remain active unless their respective registers are written to and the appropriate override bit is set, in which case they are ignored until ENSMB is driven low (Terminal mode). On power-up or when ENSMB is driven low all registers are reset to their default state. If PWDN is asserted while ENSMB is high, the registers retain their current state.

Device Functional Modes (continued)

Equalization settings accessible via the Terminal controls were chosen to meet the needs of most high speed applications. If additional fine tuning or adjustment is needed, additional equalization settings can be accessed via the SMBus registers. Each input has a total of 256 possible equalization settings. The tables show the 16 settings when the device is in Terminal mode. When using SMBus mode, the equalization, VOD and de-Emphasis levels are set by registers.

The 4-level input Terminals utilize a resistor divider to help set the 4 valid levels and provide a wider range of control settings when ENSMB=0. There is an internal 30K pull-up and a 60K pull-down connected to the package Terminal. These resistors, together with the external resistor connection combine to achieve the desired voltage level. Using the 1K pull-up, 1K pull-down, no connect, and 20K pull-down provide the optimal voltage levels for each of the four input states.

Table 2. RX-Detect Settings

| PWDN (Terminal 52) | RXDET (Terminal 22) | SMBus REG Bit[3:2] | INPUT TERMINATION | RECOMMENDED USE | COMMENTS |
|-----------------------|------------------------|-----------------------|---------------------------------------|--------------------|--|
| 0 | 0 | 00 | Hi-Z | X | Manual RX-Detect, input is high impedance mode |
| 0 | Tie 20kΩ to GND | 01 | Pre Detect: Hi-Z Post Detect: 50 Ω | PCIe only | Auto RX-Detect, outputs test every 12 msec for 600 msec then stops; termination is Hi-Z until RX detection; once detected input termination is 50 Ω Reset function by pulsing PWDN high for 5 usec then low again |
| 0 | Float (Default) | 10 | Pre Detect: Hi-Z Post Detect: 50 Ω | PCIe only | Auto RX-Detect, outputs test every 12 msec until detection occurs; termination is Hi-Z until RX detection; once detected input termination is 50 Ω |
| 0 | 1 | 11 | 50 Ω | All Others | Manual RX-Detect, input is 50 Ω |
| 1 | X | | High Impedance | X | Power down mode, input is Hi-Z, output drivers are disabled Used to reset RX-Detect State Machine when held high for 5 usec |

Table 3. OOB And Signal Detect Threshold Level⁽¹⁾

| SD_TH (Terminal 26) | SMBus REG BIT [3:2] and [1:0] | [3:2] ASSERT LEVEL (mVp-p) | | [1:0] DE-ASSERT LEVEL (mVp-p) | |
|------------------------|-------------------------------|----------------------------|---------|-------------------------------|---------|
| | | 3 Gbps | 12 Gbps | 3 Gbps | 12 Gbps |
| 0 | 10 | 18 | 75 | 14 | 55 |
| R | 01 | 12 | 40 | 8 | 22 |
| F (default) | 00 | 15 | 50 | 11 | 37 |
| 1 | 11 | 16 | 58 | 12 | 45 |

(1) VDD = 2.5V, 25°C, 11 00 11 00 pattern at 3 Gbps and 101010 pattern at 12 Gbps

Table 4. Mode Operation With Terminal Control

| MODE_B (Terminal 21) | Driver characteristics | PCIe | SAS SATA | 10GbE | CPRI OBSAI | SRIO (R)XAUI | Interlaken Infiniband |
|-------------------------|------------------------|------|-------------|-------|---------------|-----------------|--------------------------|
| 0 | Limiting | | X (≤ 6G) | X | X | X | X |
| R | Transparent without DE | | | | | | |
| F (default) | Automatic | X | | | | | |
| 1 | Transparent with DE | | X (SAS-3) | | | | |

7.4.3 MODE operation with SMBus Registers

When in SMBus mode (Slave or Master), the MODE Terminal retains control of the output driver characteristics. In order to override this control function, Register 0x08[2] must be written with a "1". Writing this bit enables MODE control of each channel individually using the channel registers defined in Table 9. For Channel-A outputs the MODE control bit is not functional. The outputs are always in a linear mode of operation. Changing these bits while Register 0x08[2]=1 will dramatically reduce the output amplitude.

7.5 Signal Conditioning Settings

Information in [Table 5](#) and [Table 6](#) shows the level of CTLE or equalization gain for Channel-B and Channel-A.

Table 5. B-Channel Equalizer Settings

| Level | EQB1 | EQB0 | EQ – 8 bits [7:0] | dB at 1.5 GHz | dB at 2.5 GHz | dB at 4 GHz | dB at 6 GHz | Suggested Use ⁽¹⁾ |
|-------|-------|-------|-------------------|---------------|---------------|-------------|-------------|------------------------------|
| 1 | 0 | 0 | 0000 0000 = 0x00 | 2.5 | 3.5 | 3.8 | 3.1 | FR4 < 5 inch trace |
| 2 | 0 | R | 0000 0001 = 0x01 | 3.8 | 5.4 | 6.7 | 6.7 | FR4 5-10 inch trace |
| 3 | 0 | Float | 0000 0010 = 0x02 | 5.0 | 7.0 | 8.4 | 8.4 | FR4 10 inch trace |
| 4 | 0 | 1 | 0000 0011 = 0x03 | 5.9 | 8.0 | 9.3 | 9.1 | FR4 15-20 inch trace |
| 5 | R | 0 | 0000 0111 = 0x07 | 7.4 | 10.3 | 12.8 | 13.7 | FR4 20-30 inch trace |
| 6 | R | R | 0001 0101 = 0x15 | 6.9 | 10.2 | 13.9 | 16.2 | FR4 25-30 inch trace |
| 7 | R | Float | 0000 1011 = 0x0B | 9.0 | 12.4 | 15.3 | 15.9 | FR4 25-30 inch trace |
| 8 | R | 1 | 0000 1111 = 0x0F | 10.2 | 13.8 | 16.7 | 17.0 | 8m, 30awg cable |
| 9 | Float | 0 | 0101 0101 = 0x55 | 8.5 | 12.6 | 17.5 | 20.7 | > 8m cable |
| 10 | Float | R | 0001 1111 = 0x1F | 11.7 | 16.2 | 20.3 | 21.8 | |
| 11 | Float | Float | 0010 1111 = 0x2F | 13.2 | 18.3 | 22.8 | 23.6 | |
| 12 | Float | 1 | 0011 1111 = 0x3F | 14.4 | 19.8 | 24.2 | 24.7 | |
| 13 | 1 | 0 | 1010 1010 = 0xAA | 14.4 | 20.5 | 26.4 | 28.0 | |
| 14 | 1 | R | 0111 1111 = 0x7F | 16.0 | 22.2 | 27.8 | 29.2 | |
| 15 | 1 | Float | 1011 1111 = 0xBF | 17.6 | 24.4 | 30.2 | 30.9 | |
| 16 | 1 | 1 | 1111 1111 = 0xFF | 18.7 | 25.8 | 31.6 | 31.9 | |

(1) Cable and FR4 lengths are for reference only. FR4 lengths based on a 100 Ohm differential stripline with 5-mil traces and 8-mil trace separation. Optimal EQ setting should be determined via simulation and prototype verification.

Table 6. A-Channel Equalizer Settings

| Level | EQA1 | EQA0 | EQ – 8 bits [7:0] | dB at 1.5 GHz | dB at 2.5 GHz | dB at 4 GHz | dB at 6 GHz | Suggested Use ⁽¹⁾ |
|-------|------|-------|-------------------|---------------|---------------|-------------|-------------|------------------------------|
| 1 | N/A | 0 | xxxx xx00 = 0x00 | 2.5 | 3.5 | 3.8 | 3.1 | |
| 2 | N/A | R | xxxx xx01 = 0x01 | 3.8 | 5.4 | 6.7 | 6.7 | |
| 3 | N/A | Float | xxxx xx10 = 0x02 | 5.0 | 7.0 | 8.4 | 8.4 | |
| 4 | N/A | 1 | xxxx xx11 = 0x03 | 5.9 | 8.0 | 9.3 | 9.1 | SAS-3 |

(1) Cable and FR4 lengths are for reference only. FR4 lengths based on a 100 Ohm differential stripline with 5-mil traces and 8-mil trace separation. Optimal EQ setting should be determined via simulation and prototype verification.

Table 7. B-Channel Output Voltage And De-Emphasis Settings

| Level | DEMB1 | DEMB0 | VOD Vp-p | DEM dB ⁽¹⁾ | Inner Amplitude Vp-p | Suggested Use ⁽²⁾ |
|-------|-------|-------|----------|-----------------------|----------------------|------------------------------|
| 1 | 0 | 0 | 0.8 | 0 | 0.8 | FR4 <5 inch trace |
| 2 | 0 | R | 0.9 | 0 | 0.9 | FR4 <5 inch trace |
| 3 | 0 | Float | 0.9 | - 3.5 | 0.6 | FR4 10 inch trace |
| 4 | 0 | 1 | 1.0 | 0 | 1.0 | FR4 <5 inch trace |
| 5 | R | 0 | 1.0 | - 3.5 | 0.7 | FR4 10 inch trace |
| 6 | R | R | 1.0 | - 6 | 0.5 | FR4 15 inch trace |
| 7 | R | Float | 1.1 | 0 | 1.1 | FR4 <5 inch trace |
| 8 | R | 1 | 1.1 | - 3.5 | 0.7 | FR4 10 inch trace |
| 9 | Float | 0 | 1.1 | - 6 | 0.6 | FR4 15 inch trace |
| 10 | Float | R | 1.2 | 0 | 1.2 | FR4 <5 inch trace |
| 11 | Float | Float | 1.2 | - 3.5 | 0.8 | FR4 10 inch trace |
| 12 | Float | 1 | 1.2 | - 6 | 0.6 | FR4 15 inch trace |
| 13 | 1 | 0 | 1.3 | 0 | 1.3 | FR4 <5 inch trace |
| 14 | 1 | R | 1.3 | - 3.5 | 0.9 | FR4 10 inch trace |
| 15 | 1 | Float | 1.3 | - 6 | 0.7 | FR4 15 inch trace |
| 16 | 1 | 1 | 1.3 | - 9 | 0.5 | FR4 20 inch trace |

(1) The VOD output amplitude and DEM de-emphasis levels are set with the DEMB[1:0] Terminals.

(2) FR4 lengths are for reference only. FR4 lengths based on a 100 Ohm differential stripline with 5-mil traces and 8-mil trace separation. Optimal DEM settings should be determined via simulation and prototype verification.

Table 8. A-Channel Output Voltage And De-Emphasis Settings

| Level | DEMA1 | DEMA0 | VID Vp-p | DEM Setting ⁽¹⁾ | VOD Vp-p |
|-------|-------|-------|----------|----------------------------|----------|
| 1 | 0 | 0 | 1.0 | 0 | 0.70 |
| 2 | 0 | R | 1.0 | 0 | 0.78 |
| 4 | 0 | 1 | 1.0 | 0 | 0.83 |
| 7 | R | Float | 1.0 | 0 | 0.88 |
| 10 | Float | R | 1.0 | 0 | 0.91 |
| 13 | 1 | 0 | 1.0 | 0 | 1.00 |

(1) The VOD output amplitude is set with the DEMA[1:0] Terminals. For SAS-3 operation the DEM level is typically left at 0 dB (SMBus control = 000'b) in order to keep the output dynamic range as large as possible. DEM settings other than 0 dB or 000'b will decrease the output dynamic range and act to limit the OUTA VOD. When operating in Terminal Mode in a SAS3 environment it is recommended to use DEMA[1:0] = 10'b.

Table 9. EEPROM Register Map - Single Device With Default Value

| EEPROM Address Byte | | Bit 7 | Bit 6 | Bit 5 | Bit 4 | Bit 3 | Bit 2 | Bit 1 | Bit 0 |
|---------------------|---|--------------------------|--------------------------|--------------------------|--------------------------|--------------------------|--------------------------|--------------------------|--------------------------|
| Description | 0 | CRC EN | Address Map Present | EEPROM > 256 Bytes | RES | DEVICE COUNT[3] | DEVICE COUNT[2] | DEVICE COUNT[1] | DEVICE COUNT[0] |
| Value | | 00 | 0 | 0 | 0 | 0 | 0 | 0 | 0 |
| Description | 1 | RES | RES | RES | RES | RES | RES | RES | RES |
| Value | | 00 | 0 | 0 | 0 | 0 | 0 | 0 | 0 |
| Description | 2 | Max EEPROM Burst size[7] | Max EEPROM Burst size[6] | Max EEPROM Burst size[5] | Max EEPROM Burst size[4] | Max EEPROM Burst size[3] | Max EEPROM Burst size[2] | Max EEPROM Burst size[1] | Max EEPROM Burst size[0] |
| Value | | 00 | 0 | 0 | 0 | 0 | 0 | 0 | 0 |
| Description | 3 | PWDN_CH7 | PWDN_CH6 | PWDN_CH5 | PWDN_CH4 | PWDN_CH3 | PWDN_CH2 | PWDN_CH1 | PWDN_CH0 |
| SMBus Register | | 0x01 [7] | 0x01 [6] | 0x01 [5] | 0x01 [4] | 0x01 [3] | 0x01 [2] | 0x01 [1] | 0x01 [0] |
| Value | | 00 | 0 | 0 | 0 | 0 | 0 | 0 | 0 |
| Description | 4 | Reserved | Reserved | Reserved | Reserved | Ovrd_PWDN | CH7_EQ_LIM | CH6_EQ_LIM | CH5_EQ_LIM |
| SMBus Register | | 0x02 [5] | 0x02 [4] | 0x02 [3] | 0x02 [2] | 0x02 [0] | 0x04 [7] | 0x04 [6] | 0x04 [5] |
| Value | | 00 | 0 | 0 | 0 | 0 | 0 | 0 | 0 |
| Description | 5 | CH4_EQ_LIM | CH3_EQ_LIM | CH2_EQ_LIM | CH1_EQ_LIM | CH0_EQ_LIM | rxdet_btb_en | Ovrd_SD_TH | Reserved |
| SMBus Register | | 0x04 [4] | 0x04 [3] | 0x04 [2] | 0x04 [1] | 0x04 [0] | 0x06 [4] | 0x08 [6] | 0x08 [5] |
| Value | | 04 | 0 | 0 | 0 | 0 | 1 | 0 | 0 |
| Description | 6 | Ovrd_IDLE | Ovrd_RX_DET | Ovrd_MODE | Reserved | Reserved | rxdet_delay_2 | rxdet_delay_1 | rxdet_delay_0 |
| SMBus Register | | 0x08 [4] | 0x08 [3] | 0x08 [2] | 0x08 [1] | 0x08 [0] | 0x0B [6] | 0x0B [5] | 0x0B [4] |
| Value | | 07 | 0 | 0 | 0 | 0 | 1 | 1 | 1 |
| Description | 7 | rate_delay_3 | rate_delay_2 | rate_delay_1 | rate_delay_0 | CH0_Idle_auto | CH0_Idle_sel | CH0_Rxdet_1 | CH0_Rxdet_0 |
| SMBus Register | | 0x0B [3] | 0x0B [2] | 0x0B [1] | 0x0B [0] | 0x0E [5] | 0x0E [4] | 0x0E [3] | 0x0E [2] |
| Value | | 00 | 0 | 0 | 0 | 0 | 0 | 0 | 0 |
| Description | 8 | CH0_EQ_7 | CH0_EQ_6 | CH0_EQ_5 | CH0_EQ_4 | CH0_EQ_3 | CH0_EQ_2 | CH0_EQ_1 | CH0_EQ_0 |
| SMBus Register | | 0x0F [7] | 0x0F [6] | 0x0F [5] | 0x0F [4] | 0x0F [3] | 0x0F [2] | 0x0F [1] | 0x0F [0] |
| Value | | 2F | 0 | 0 | 1 | 0 | 1 | 1 | 1 |
| Description | 9 | CH0_SCP | CH0_MODE | Reserved | Reserved | Reserved | CH0_VOD_2 | CH0_VOD_1 | CH0_VOD_0 |
| SMBus Register | | 0x10 [7] | 0x10 [6] | 0x10 [5] | 0x10 [4] | 0x10 [3] | 0x10 [2] | 0x10 [1] | 0x10 [0] |
| Value | | AD | 1 | 0 | 1 | 0 | 1 | 1 | 0 |

Table 9. EEPROM Register Map - Single Device With Default Value (continued)

| EEPROM Address Byte | | Bit 7 | Bit 6 | Bit 5 | Bit 4 | Bit 3 | Bit 2 | Bit 1 | Bit 0 |
|---------------------|----|---------------|--------------|-------------|-------------|---------------|--------------|-------------|-------------|
| Description | A | CH0_DEM_2 | CH0_DEM_1 | CH0_DEM_0 | Reserved | CH0_THa_1 | CH0_THa_0 | CH0_THd_1 | CH0_THd_0 |
| SMBus Register | | 0x11 [2] | 0x11 [1] | 0x11 [0] | 0x12 [7] | 0x12 [3] | 0x12 [2] | 0x12 [1] | 0x12 [0] |
| Value | | 40 | 0 | 1 | 0 | 0 | 0 | 0 | 0 |
| Description | B | CH1_Idle_auto | CH1_Idle_sel | CH1_Rxdet_1 | CH1_Rxdet_0 | CH1_EQ_7 | CH1_EQ_6 | CH1_EQ_5 | CH1_EQ_4 |
| SMBus Register | | 0x15 [5] | 0x15 [4] | 0x15 [3] | 0x15 [2] | 0x16 [7] | 0x16 [6] | 0x16 [5] | 0x16 [4] |
| Value | | 02 | 0 | 0 | 0 | 0 | 0 | 1 | 0 |
| Description | C | CH1_EQ_3 | CH1_EQ_2 | CH1_EQ_1 | CH1_EQ_0 | CH1_SCP | CH1_MODE | Reserved | Reserved |
| SMBus Register | | 0x16 [3] | 0x16 [2] | 0x16 [1] | 0x16 [0] | 0x17 [7] | 0x17 [6] | 0x17 [5] | 0x17 [4] |
| Value | | FA | 1 | 1 | 1 | 1 | 1 | 0 | 1 |
| Description | D | Reserved | CH1_VOD_2 | CH1_VOD_1 | CH1_VOD_0 | CH1_DEM_2 | CH1_DEM_1 | CH1_DEM_0 | Reserved |
| SMBus Register | | 0x17 [3] | 0x17 [2] | 0x17 [1] | 0x17 [0] | 0x18 [2] | 0x18 [1] | 0x18 [0] | 0x19 [7] |
| Value | | D4 | 1 | 1 | 0 | 1 | 0 | 1 | 0 |
| Description | E | CH1_THa_1 | CH1_THa_0 | CH1_THd_1 | CH1_THd_0 | CH2_Idle_auto | CH2_Idle_sel | CH2_Rxdet_1 | CH2_Rxdet_0 |
| SMBus Register | | 0x19 [3] | 0x19 [2] | 0x19 [1] | 0x19 [0] | 0x1C [5] | 0x1C [4] | 0x1C [3] | 0x1C [2] |
| Value | | 00 | 0 | 0 | 0 | 0 | 0 | 0 | 0 |
| Description | F | CH2_EQ_7 | CH2_EQ_6 | CH2_EQ_5 | CH2_EQ_4 | CH2_EQ_3 | CH2_EQ_2 | CH2_EQ_1 | CH2_EQ_0 |
| SMBus Register | | 0x1D [7] | 0x1D [6] | 0x1D [5] | 0x1D [4] | 0x1D [3] | 0x1D [2] | 0x1D [1] | 0x1D [0] |
| Value | | 2F | 0 | 0 | 1 | 0 | 1 | 1 | 1 |
| Description | 10 | CH2_SCP | CH2_MODE | Reserved | Reserved | Reserved | CH2_VOD_2 | CH2_VOD_1 | CH2_VOD_0 |
| SMBus Register | | 0x1E [7] | 0x1E [6] | 0x1E [5] | 0x1E [4] | 0x1E [3] | 0x1E [2] | 0x1E [1] | 0x1E [0] |
| Value | | AD | 1 | 0 | 1 | 0 | 1 | 1 | 0 |
| Description | 11 | CH2_DEM_2 | CH2_DEM_1 | CH2_DEM_0 | Reserved | CH2_THa_1 | CH2_THa_0 | CH2_THd_1 | CH2_THd_0 |
| SMBus Register | | 0x1F [2] | 0x1F [1] | 0x1F [0] | 0x20 [7] | 0x20 [3] | 0x20 [2] | 0x20 [1] | 0x20 [0] |
| Value | | 40 | 0 | 1 | 0 | 0 | 0 | 0 | 0 |
| Description | 12 | CH3_Idle_auto | CH3_Idle_sel | CH3_Rxdet_1 | CH3_Rxdet_0 | CH3_EQ_7 | CH3_EQ_6 | CH3_EQ_5 | CH3_EQ_4 |
| SMBus Register | | 0x23 [5] | 0x23 [4] | 0x23 [3] | 0x23 [2] | 0x24 [7] | 0x24 [6] | 0x24 [5] | 0x24 [4] |
| Value | | 02 | 0 | 0 | 0 | 0 | 0 | 1 | 0 |
| Description | 13 | CH3_EQ_3 | CH3_EQ_2 | CH3_EQ_1 | CH3_EQ_0 | CH3_SCP | CH3_MODE | Reserved | Reserved |
| SMBus Register | | 0x24 [3] | 0x24 [2] | 0x24 [1] | 0x24 [0] | 0x25 [7] | 0x25 [6] | 0x25 [5] | 0x25 [4] |
| Value | | FA | 1 | 1 | 1 | 1 | 1 | 0 | 1 |

Table 9. EEPROM Register Map - Single Device With Default Value (continued)

| EEPROM Address Byte | | Bit 7 | Bit 6 | Bit 5 | Bit 4 | Bit 3 | Bit 2 | Bit 1 | Bit 0 |
|---------------------|----|-----------------|----------------|----------------|---------------|----------------|------------------|-----------------|-----------------|
| Description | 14 | Reserved | CH3_VOD_2 | CH3_VOD_1 | CH3_VOD_0 | CH3_DEM_2 | CH3_DEM_1 | CH3_DEM_0 | Reserved |
| SMBus Register | | 0x25 [3] | 0x25 [2] | 0x25 [1] | 0x25 [0] | 0x26 [2] | 0x26 [1] | 0x26 [0] | 0x27 [7] |
| Value | | D4 | 1 | 1 | 0 | 1 | 0 | 1 | 0 |
| Description | 15 | CH3_THa_1 | CH3_THa_0 | CH3_THd_1 | CH3_THd_0 | ovrd_fast_idle | hi_idle_th CH0-3 | hi_idle_thCH4-7 | fast_idle CH0-3 |
| SMBus Register | | 0x27 [3] | 0x27 [2] | 0x27 [1] | 0x27 [0] | 0x28 [6] | 0x28 [5] | 0x28 [4] | 0x28 [3] |
| Value | | 09 | 0 | 0 | 0 | 0 | 1 | 0 | 0 |
| Description | 16 | fast_idle CH4-7 | low_gain CH0-3 | low_gain CH4-7 | CH4_Idle_auto | CH4_Idle_sel | CH4_Rxdet_1 | CH4_Rxdet_0 | Reserved |
| SMBus Register | | 0x28 [2] | 0x28 [1] | 0x28 [0] | 0x2B [5] | 0x2B [4] | 0x2B [3] | 0x2B [2] | 0x2C [7] |
| Value | | 80 | 1 | 0 | 0 | 0 | 0 | 0 | 0 |
| Description | 17 | Reserved | Reserved | Reserved | Reserved | Reserved | CH4_EQ_1 | CH4_EQ_0 | CH4_SCP |
| SMBus Register | | 0x2C [6] | 0x2C [5] | 0x2C [4] | 0x2C [3] | 0x2C [2] | 0x2C [1] | 0x2C [0] | 0x2D [7] |
| Value | | 5F | 0 | 1 | 0 | 1 | 1 | 1 | 1 |
| Description | 18 | Reserved | Reserved | Reserved | Reserved | CH4_VOD_2 | CH4_VOD_1 | CH4_VOD_0 | CH4_DEM_2 |
| SMBus Register | | 0x2D [6] | 0x2D [5] | 0x2D [4] | 0x2D [3] | 0x2D [2] | 0x2D [1] | 0x2D [0] | 0x2E [2] |
| Value | | 5A | 0 | 1 | 0 | 1 | 1 | 0 | 1 |
| Description | 19 | CH4_DEM_1 | CH4_DEM_0 | Reserved | CH4_THa_1 | CH4_THa_0 | CH4_THd_1 | CH4_THd_0 | CH5_Idle_auto |
| SMBus Register | | 0x2E [1] | 0x2E [0] | 0x2F [7] | 0x2F [3] | 0x2F [2] | 0x2F [1] | 0x2F [0] | 0x32 [5] |
| Value | | 80 | 1 | 0 | 0 | 0 | 0 | 0 | 0 |
| Description | 1A | CH5_Idle_sel | CH5_Rxdet_1 | CH5_Rxdet_0 | Reserved | Reserved | Reserved | Reserved | Reserved |
| SMBus Register | | 0x32 [4] | 0x32 [3] | 0x32 [2] | 0x33 [7] | 0x33 [6] | 0x33 [5] | 0x33 [4] | 0x33 [3] |
| Value | | 05 | 0 | 0 | 0 | 0 | 1 | 0 | 1 |
| Description | 1B | Reserved | CH5_EQ_1 | CH5_EQ_0 | CH5_SCP | Reserved | Reserved | Reserved | Reserved |
| SMBus Register | | 0x33 [2] | 0x33 [1] | 0x33 [0] | 0x34 [7] | 0x34 [6] | 0x34 [5] | 0x34 [4] | 0x34 [3] |
| Value | | F5 | 1 | 1 | 1 | 1 | 0 | 1 | 0 |
| Description | 1C | CH5_VOD_2 | CH5_VOD_1 | CH5_VOD_0 | CH5_DEM_2 | CH5_DEM_1 | CH5_DEM_0 | Reserved | CH5_THa_1 |
| SMBus Register | | 0x34 [2] | 0x34 [1] | 0x34 [0] | 0x35 [2] | 0x35 [1] | 0x35 [0] | 0x36 [7] | 0x36 [3] |
| Value | | A8 | 1 | 0 | 1 | 0 | 1 | 0 | 0 |
| Description | 1D | CH5_THa_0 | CH5_THd_1 | CH5_THd_0 | CH6_Idle_auto | CH6_Idle_sel | CH6_Rxdet_1 | CH6_Rxdet_0 | Reserved |
| SMBus Register | | 0x36 [2] | 0x36 [1] | 0x36 [0] | 0x39 [5] | 0x39 [4] | 0x39 [3] | 0x39 [2] | 0x3A [7] |
| Value | | 00 | 0 | 0 | 0 | 0 | 0 | 0 | 0 |

Table 9. EEPROM Register Map - Single Device With Default Value (continued)

| EEPROM Address Byte | | Bit 7 | Bit 6 | Bit 5 | Bit 4 | Bit 3 | Bit 2 | Bit 1 | Bit 0 |
|---------------------|----|--------------|-------------|-------------|-----------|-----------|-----------|-----------|---------------|
| Description | 1E | Reserved | Reserved | Reserved | Reserved | Reserved | CH6_EQ_1 | CH6_EQ_0 | CH6_SCP |
| SMBus Register | | 0x3A [6] | 0x3A [5] | 0x3A [4] | 0x3A [3] | 0x3A [2] | 0x3A [1] | 0x3A [0] | 0x3B [7] |
| Value | | 5F | 0 | 1 | 0 | 1 | 1 | 1 | 1 |
| Description | 1F | Reserved | Reserved | Reserved | Reserved | CH6_VOD_2 | CH6_VOD_1 | CH6_VOD_0 | CH6_DEM_2 |
| SMBus Register | | 0x3B [6] | 0x3B [5] | 0x3B [4] | 0x3B [3] | 0x3B [2] | 0x3B [1] | 0x3B [0] | 0x3C [2] |
| Value | | 5A | 0 | 1 | 0 | 1 | 1 | 0 | 1 |
| Description | 20 | CH6_DEM_1 | CH6_DEM_0 | Reserved | CH6_THa_1 | CH6_THa_0 | CH6_THd_1 | CH6_THd_0 | CH7_Idle_auto |
| SMBus Register | | 0x3C [1] | 0x3C [0] | 0x3D [7] | 0x3D [3] | 0x3D [2] | 0x3D [1] | 0x3D [0] | 0x40 [5] |
| Value | | 80 | 1 | 0 | 0 | 0 | 0 | 0 | 0 |
| Description | 21 | CH7_Idle_sel | CH7_Rxdet_1 | CH7_Rxdet_0 | Reserved | Reserved | Reserved | Reserved | Reserved |
| SMBus Register | | 0x40 [4] | 0x40 [3] | 0x40 [2] | 0x41 [7] | 0x41 [6] | 0x41 [5] | 0x41 [4] | 0x41 [3] |
| Value | | 05 | 0 | 0 | 0 | 0 | 0 | 1 | 0 |
| Description | 22 | Reserved | CH7_EQ_1 | CH7_EQ_0 | CH7_SCP | Reserved | Reserved | Reserved | Reserved |
| SMBus Register | | 0x41 [2] | 0x41 [1] | 0x41 [0] | 0x42 [7] | 0x42 [6] | 0x42 [5] | 0x42 [4] | 0x42 [3] |
| Value | | F5 | 1 | 1 | 1 | 1 | 0 | 1 | 0 |
| Description | 23 | CH7_VOD_2 | CH7_VOD_1 | CH7_VOD_0 | CH7_DEM_2 | CH7_DEM_1 | CH7_DEM_0 | Reserved | CH7_THa_1 |
| SMBus Register | | 0x42 [2] | 0x42 [1] | 0x42 [0] | 0x43 [2] | 0x43 [1] | 0x43 [0] | 0x44 [7] | 0x44 [3] |
| Value | | A8 | 1 | 0 | 1 | 0 | 1 | 0 | 0 |
| Description | 24 | CH7_THa_0 | CH7_THd_1 | CH7_THd_0 | Reserved | Reserved | Reserved | Reserved | Reserved |
| SMBus Register | | 0x44 [2] | 0x44 [1] | 0x44 [0] | 0x47 [3] | 0x47 [2] | 0x47 [2] | 0x47 [0] | 0x48 [7] |
| Value | | 00 | 0 | 0 | 0 | 0 | 0 | 0 | 0 |
| Description | 25 | Reserved | Reserved | Reserved | Reserved | Reserved | Reserved | Reserved | Reserved |
| SMBus Register | | 0x48 [6] | 0x4C [7] | 0x4C [6] | 0x4C [5] | 0x4C [4] | 0x4C [3] | 0x4C [0] | 0x59 [0] |
| Value | | 00 | 0 | 0 | 0 | 0 | 0 | 0 | 0 |
| Description | 26 | Reserved | Reserved | Reserved | Reserved | Reserved | Reserved | Reserved | Reserved |
| SMBus Register | | 0x5A [7] | 0x5A [6] | 0x5A [5] | 0x5A [4] | 0x5A [3] | 0x5A [2] | 0x5A [1] | 0x5A [0] |
| Value | | 54 | 0 | 1 | 0 | 1 | 0 | 1 | 0 |
| Description | 27 | Reserved | Reserved | Reserved | Reserved | Reserved | Reserved | Reserved | Reserved |
| SMBus Register | | 0x5B [7] | 0x5B [6] | 0x5B [5] | 0x5B [4] | 0x5B [3] | 0x5B [2] | 0x5B [1] | 0x5B [0] |
| Value | | 54 | 0 | 1 | 0 | 1 | 0 | 1 | 0 |

Table 10. Example Of EEPROM For Four Devices Using Two Address Maps

| EEPROM Address | Address (Hex) | EEPROM Data | Comments |
|----------------|---------------|-------------|--|
| 0 | 00 | 0x43 | CRC_EN = 0, Address Map = 1, >256 bytes = 0, Device Count[3:0] = 3 |
| 1 | 01 | 0x00 | |
| 2 | 02 | 0x08 | EEPROM Burst Size |
| 3 | 03 | 0x00 | CRC not used |
| 4 | 04 | 0x0B | Device 0 Address Location |
| 5 | 05 | 0x00 | CRC not used |
| 6 | 06 | 0x0B | Device 1 Address Location |
| 7 | 07 | 0x00 | CRC not used |
| 8 | 08 | 0x30 | Device 2 Address Location |
| 9 | 09 | 0x00 | CRC not used |
| 10 | 0A | 0x30 | Device 3 Address Location |
| 11 | 0B | 0x00 | Begin Device 0, 1 - Address Offset 3 |
| 12 | 0C | 0x00 | |
| 13 | 0D | 0x04 | |
| 14 | 0E | 0x07 | |
| 15 | 0F | 0x00 | |
| 16 | 10 | 0x01 | EQ CHB0 = 01 |
| 17 | 11 | 0xAD | VOD CHB0 = 1.2V |
| 18 | 12 | 0x00 | DEM CHB0 = 0 (0dB) |
| 19 | 13 | 0x00 | EQ CHB1 = 01 |
| 20 | 14 | 0x1A | VOD CHB1 = 1.2V |
| 21 | 15 | 0xD0 | DEM CHB1 = 0 (0dB) |
| 22 | 16 | 0x00 | |
| 23 | 17 | 0x01 | EQ CHB2 = 01 |
| 24 | 18 | 0xAD | VOD CHB2 = 1.2V |
| 25 | 19 | 0x00 | DEM CHB2 = 0 (0dB) |
| 26 | 1A | 0x00 | EQ CHB3 = 01 |
| 27 | 1B | 0x1A | VOD CHB3 = 1.2V |
| 28 | 1C | 0xD0 | DEM CHB3 = 0 (0dB) |
| 29 | 1D | 0x09 | Signal Detect Control |
| 30 | 1E | 0x80 | Signal Detect Control |
| 31 | 1F | 0x07 | EQ CHA0 = 03 |
| 32 | 20 | 0x5E | VOD CHA0 = 111'b |
| 33 | 21 | 0x00 | DEM CHA0 = 0 (0dB) |
| 34 | 22 | 0x00 | EQ CHA1 = 03 |
| 35 | 23 | 0x75 | VOD CHA1 = 111'b |
| 36 | 24 | 0xE0 | DEM CHA1 = 0 (0dB) |
| 37 | 25 | 0x00 | |
| 38 | 26 | 0x07 | EQ CHA2 = 03 |
| 39 | 27 | 0x5E | VOD CHA2 = 1.4V |
| 40 | 28 | 0x00 | DEM CHA2 = 0 (0dB) |
| 41 | 29 | 0x00 | EQ CHA3 = 03 |
| 42 | 2A | 0x75 | VOD CHA3 = 111'b |
| 43 | 2B | 0xE0 | DEM CHA3 = 0 (0dB) |
| 44 | 2C | 0x00 | |
| 45 | 2D | 0x00 | |
| 46 | 2E | 0x54 | |

Table 10. Example Of EEPROM For Four Devices Using Two Address Maps (continued)

| EEPROM Address | Address (Hex) | EEPROM Data | Comments |
|----------------|---------------|-------------|--------------------------------------|
| 47 | 2F | 0x54 | End Device 0, 1 - Address Offset 39 |
| 48 | 30 | 0x00 | Begin Device 2, 3 - Address Offset 3 |
| 49 | 31 | 0x00 | |
| 50 | 32 | 0x04 | |
| 51 | 33 | 0x07 | |
| 52 | 34 | 0x00 | |
| 53 | 35 | 0x01 | EQ CHB0 = 01 |
| 54 | 36 | 0xAB | VOD CHB0 = 1.0V |
| 55 | 37 | 0x00 | DEM CHB0 = 0 (0dB) |
| 56 | 38 | 0x00 | EQ CHB1 = 01 |
| 57 | 39 | 0x1A | VOD CHB1 = 1.0V |
| 58 | 3A | 0xB0 | DEM CHB1 = 0 (0dB) |
| 59 | 3B | 0x00 | |
| 60 | 3C | 0x01 | EQ CHB2 = 01 |
| 61 | 3D | 0xAB | VOD CHB2 = 1.0V |
| 62 | 3E | 0x00 | DEM CHB2 = 0 (0dB) |
| 63 | 3F | 0x00 | EQ CHB3 = 01 |
| 64 | 40 | 0x1A | VOD CHB3 = 1.0V |
| 65 | 41 | 0xB0 | DEM CHB3 = 0 (0dB) |
| 66 | 42 | 0x09 | Signal Detect Control |
| 67 | 43 | 0x80 | Signal Detect Control |
| 68 | 44 | 0x03 | EQ CHA0 = 01 |
| 69 | 45 | 0x5E | VOD CHA0 = 111'b |
| 70 | 46 | 0x00 | DEM CHA0 = 0 (0dB) |
| 71 | 47 | 0x00 | EQ CHA1 = 01 |
| 72 | 48 | 0x35 | VOD CHA1 = 111'b |
| 73 | 49 | 0xE0 | DEM CHA1 = 0 (0dB) |
| 74 | 4A | 0x00 | |
| 75 | 4B | 0x03 | EQ CHA2 = 01 |
| 76 | 4C | 0x5E | VOD CHA2 = 111'b |
| 77 | 4D | 0x00 | DEM CHA2 = 0 (0dB) |
| 78 | 4E | 0x00 | EQ CHA3 = 01 |
| 79 | 4F | 0x35 | VOD CHA3 = 111'b |
| 80 | 50 | 0xE0 | DEM CHA3 = 0 (0dB) |
| 81 | 51 | 0x00 | |
| 82 | 52 | 0x00 | |
| 83 | 53 | 0x54 | |
| 84 | 54 | 0x54 | End Device 2, 3 - Address Offset 39 |

Note: CRC_EN = 0, Address Map = 1, >256 byte = 0, Device Count[3:0] = 3. Multiple devices can point to the same address map. Maximum EEPROM size is 8 kbits (1024 x 8-bits).

7.7 Register Maps

The System Management Bus interface is compatible to SMBus 2.0 physical layer specification. ENSMB = 1kΩ to VDD to enable SMBus slave mode and allow access to the configuration registers.

The DS125BR401A has the AD[3:0] inputs in SMBus mode. These Terminals are the user set SMBus slave address inputs. The AD[3:0] Terminals have internal pull-down. When left floating or pulled low the AD[3:0] = 0000'b, the device default address byte is B0'h. Based on the SMBus 2.0 specification, the DS125BR401A has a 7-bit slave address. The LSB is set to 0'b (for a WRITE). The device supports up to 16 address byte, which can be set with the AD[3:0] inputs. Below are the 16 addresses.

Table 11. Device Slave Address Bytes

| AD[3:0] Settings | Address Bytes (HEX) |
|------------------|---------------------|
| 0000 | B0 |
| 0001 | B2 |
| 0010 | B4 |
| 0011 | B6 |
| 0100 | B8 |
| 0101 | BA |
| 0110 | BC |
| 0111 | BE |
| 1000 | C0 |
| 1001 | C2 |
| 1010 | C4 |
| 1011 | C6 |
| 1100 | C8 |
| 1101 | CA |
| 1110 | CC |
| 1111 | CE |

The SDA, SCL Terminals are 3.3V tolerant, but are not 5V tolerant. External pull-up resistor is required on the SDA. The resistor value can be from 1 kΩ to 5 kΩ depending on the voltage, loading and speed. The SCL may also require an external pull-up resistor and it depends on the Host that drives the bus.

7.7.1 Transfer Of Data Via The SMBus

During normal operation the data on SDA must be stable during the time when SCL is High.

There are three unique states for the SMBus:

START: A High-to-Low transition on SDA while SCL is High indicates a message START condition.

STOP: A Low-to-High transition on SDA while SCL is High indicates a message STOP condition.

IDLE: If SCL and SDA are both High for a time exceeding t_{BUF} from the last detected STOP condition or if they are High for a total exceeding the maximum specification for t_{HIGH} then the bus will transfer to the IDLE state.

7.7.2 SMBus Transactions

The device supports WRITE and READ transactions. See [Table 12](#) for register address, type (Read/Write, Read Only), default value and function information.

7.7.3 Writing a Register

To write a register, the following protocol is used (see SMBus 2.0 specification).

1. The Host drives a START condition, the 7-bit SMBus address, and a “0” indicating a WRITE.
2. The Device (Slave) drives the ACK bit (“0”).
3. The Host drives the 8-bit Register Address.
4. The Device drives an ACK bit (“0”).
5. The Host drive the 8-bit data byte.
6. The Device drives an ACK bit (“0”).
7. The Host drives a STOP condition.

The WRITE transaction is completed, the bus goes IDLE and communication with other SMBus devices may now occur.

7.7.4 Reading a Register

To read a register, the following protocol is used (see SMBus 2.0 specification).

1. The Host drives a START condition, the 7-bit SMBus address, and a “0” indicating a WRITE.
2. The Device (Slave) drives the ACK bit (“0”).
3. The Host drives the 8-bit Register Address.
4. The Device drives an ACK bit (“0”).
5. The Host drives a START condition.
6. The Host drives the 7-bit SMBus Address, and a “1” indicating a READ.
7. The Device drives an ACK bit “0”.
8. The Device drives the 8-bit data value (register contents).
9. The Host drives a NACK bit “1” indicating end of the READ transfer.
10. The Host drives a STOP condition.

The READ transaction is completed, the bus goes IDLE and communication with other SMBus devices may now occur.

[Table 12](#) for more information.

Table 12. SMBus Slave Mode Register Map

| Address | Register Name | Bit | Field | Type | Default | Description |
|---------|---------------|-----|------------------------|------|---------|--|
| 0x00 | Observation | 7 | Reserved | R/W | 0x00 | Set bit to 0. |
| | | 6:3 | Address Bit AD[3:0] | R | | Observation of AD[3:0] bits [6]: AD3 [5]: AD2 [4]: AD1 [3]: AD0 |
| | | 2 | EEPROM Read Done | R | | 1: Device completed the read from external EEPROM. |
| | | 1 | Reserved | R/W | | Set bit to 0. |
| | | 0 | Reserved | R/W | | Set bit to 0. |
| 0x01 | PWDN Channels | 7:0 | PWDN CHx | R/W | 0x00 | Power Down per Channel [7]: CH7 – CHA_3 [6]: CH6 – CHA_2 [5]: CH5 – CHA_1 [4]: CH4 – CHA_0 [3]: CH3 – CHB_3 [2]: CH2 – CHB_2 [1]: CH1 – CHB_1 [0]: CH0 – CHB_0 00'h = all channels enabled FF'h = all channels disabled Note: override PWDN Terminal. |

Table 12. SMBus Slave Mode Register Map (continued)

| Address | Register Name | Bit | Field | Type | Default | Description |
|---------|---------------------------|-----|------------------------|------|---------|---|
| 0x02 | Override PWDN | 7:1 | Reserved | R/W | 0x00 | Set bits to 0. |
| | | 0 | Override PWDN Terminal | | | 1: Block PWDN Terminal control 0: Allow PWDN Terminal control |
| 0x04 | EQ Limiting | 7:0 | EQ Control | R/W | 0x00 | CH3 - CH0 EQ Limiting Control [7]: CH7 – CHA_3 (linear only) [6]: CH6 – CHA_2 (linear only) [5]: CH5 – CHA_1 (linear only) [4]: CH4 – CHA_0 (linear only) [3]: CH3 – CHB_3 [2]: CH2 – CHB_2 [1]: CH1 – CHB_1 [0]: CH0 – CHB_0 00'h = all channels linear EQ 0F'h = B-channels limiting EQ Note: These bits do not connect to the A-Channel |
| 0x05 | Slave Mode CRC bits | 7:0 | CRC bits | R/W | 0x00 | CRC bits [7:0] |
| 0x06 | Slave Register Control | 7:5 | Reserved | R/W | 0x10 | Set bits to 0. |
| | | 4 | Reserved | | | Set bit to 1. |
| | | 3 | Register Enable | | | 1: Enables high speed channel control via SMBus registers without CRC 0: Channel control via SMBus registers requires correct CRC in Reg 0x05 Note: In order to change VOD, DEM and EQ of the channels in slave mode without also setting CRC each time, set this bit to 1. |
| | | 2:0 | Reserved | | | Set bits to 0. |
| 0x07 | Digital Reset and Control | 7 | Reserved | R/W | 0x01 | Set bit to 0. |
| | | 6 | Reset Registers | | | Self clearing reset for SMBus registers. Writing a [1] will return register settings to default values. |
| | | 5 | Reset SMBus Master | | | Self clearing reset to SMBus master state machine |
| | | 4:0 | Reserved | | | Set bits to 0 0001'b. |
| 0x08 | Override Terminal Control | 7 | Reserved | R/W | 0x00 | Set bit to 0. |
| | | 6 | Override SD_TH | | | 1: Block SD_TH Terminal control 0: Allow SD_TH Terminal control |
| | | 5 | Reserved | | | Set bit to 0. |
| | | 4 | Override IDLE | | | 1: IDLE control by registers 0: IDLE control by signal detect Note: These bits do not connect to the A-Channel |
| | | 3 | Override RXDET | | | 1: Block RXDET Terminal control 0: Allow RXDET Terminal control |
| | | 2 | Override MODE_B | | | 1: Block MODE_B Terminal control 0: Allow MODE_B Terminal control |
| | | 1 | Reserved | | | Set bit to 0. |
| | | 0 | Reserved | | | Set bit to 0. |
| 0x0A | Signal Detect Monitor | 7:0 | IDLE Status | R | 0x00 | CH7 - CH0 Internal IDLE indicator [7]: CH7 – CHA_3 [6]: CH6 – CHA_2 [5]: CH5 – CHA_1 [4]: CH4 – CHA_0 [3]: CH3 – CHB_3 [2]: CH2 – CHB_2 [1]: CH1 – CHB_1 [0]: CH0 – CHB_0 0'b = Signal Detected at input 1'b = Signal Detected at input Note: These bits only function when MODE_B terminal = FLOAT |

Table 12. SMBus Slave Mode Register Map (continued)

| Address | Register Name | Bit | Field | Type | Default | Description |
|---------|---------------------------|-----|-----------------------------|------|---------|--|
| 0x0E | CH0 - CHB0 IDLE, RXDET | 7:6 | Reserved | R/W | 0x00 | Set bits to 0. |
| | | 5 | IDLE_AUTO | | | 1: Automatic IDLE detect 0: Allow IDLE_SEL control in bit 4 Note: override IDLE control. |
| | | 4 | IDLE_SEL | | | 1: Output is MUTED (electrical idle) 0: Output is ON Note: override IDLE control. |
| | | 3:2 | RXDET | | | 00: Input is high-z impedance 01: Auto RX-Detect, outputs test every 12 ms for 600 ms (50 times) then stops; termination is high-z until detection; once detected input termination is 50 Ω 10: Auto RX-Detect, outputs test every 12 ms until detection occurs; termination is high-z until detection; once detected input termination is 50 Ω 11: Input is 50 Ω Note: override RXDET Terminal. |
| | | 1:0 | Reserved | | | Set bits to 0. |
| 0x0F | CH0 - CHB0 EQ | 7:0 | EQ Control | R/W | 0x2F | INB_0 EQ Control - total of 256 levels. See Table 5 . |
| 0x10 | CH0 - CHB_0 VOD | 7 | Short Circuit Protection | R/W | 0xAD | 1: Enable the short circuit protection 0: Disable the short circuit protection |
| | | 6 | MODE_SEL | | | 1: PCIe Gen 1/2 0: SAS-3 and PCIe Gen 3 Note: override the MODE_B Terminal. |
| | | 5:3 | Reserved | | | Set bits to default value - 101. |
| | | 2:0 | VOD Control | | | OUTB_0 VOD Control 000: 0.7 V 001: 0.8 V 010: 0.9 V 011: 1.0 V 100: 1.1 V 101: 1.2 V (default) 110: 1.3 V 111: 1.4 V |
| 0x11 | CH0 - CHB_0 DEM | 7 | RXDET STATUS | R | 0x02 | Observation bit for RXDET CH0 - CHB_0. 1: RX = detected 0: RX = not detected |
| | | 6:5 | MODE_DET STATUS | R | | Observation bit for MODE_DET CH0 - CHB_0. 00: GEN1 (2.5G data-rate) 01: GEN2 (5G data-rate) 11: GEN3 (8G+ data-rate) Note: Only functions when MODE_B Terminal = Automatic |
| | | 4:3 | Reserved | R/W | | Set bits to 0. |
| | | 2:0 | DEM Control | R/W | | OUTB_0 DEM Control 000: 0 dB 001: -1.5 dB 010: -3.5 dB (default) 011: -5 dB 100: -6 dB 101: -8 dB 110: -9 dB 111: -12 dB |

Table 12. SMBus Slave Mode Register Map (continued)

| Address | Register Name | Bit | Field | Type | Default | Description |
|---------|-----------------------------|-----|-----------------------------|------|---------|--|
| 0x12 | CH0 - CHB_0 SD Threshold | 7:4 | Reserved | R/W | 0x00 | Set bits to 0. |
| | | 3:2 | IDLE tha | | | Assert threshold (1010 pattern 12 Gbps) 00 = 50 mVp-p (default) 01 = 40 mVp-p 10 = 75 mVp-p 11 = 58 mVp-p Note: override the SD_TH Terminal using 0x08[6]. |
| | | 1:0 | IDLE thd | | | De-assert threshold (1010 pattern 12 Gbps) 00 = 37 mVp-p (default) 01 = 22 mVp-p 10 = 55 mVp-p 11 = 45 mVp-p Note: override the SD_TH Terminal using 0x08[6]. |
| 0x15 | CH1 - CHB_1 IDLE, RXDET | 7:6 | Reserved | R/W | 0x00 | Set bits to 0. |
| | | 5 | IDLE_AUTO | | | 1: Automatic IDLE detect 0: Allow IDLE_SEL control in bit 4 Note: override IDLE control. |
| | | 4 | IDLE_SEL | | | 1: Output is MUTED (electrical idle) 0: Output is ON Note: override IDLE control. |
| | | 3:2 | RXDET | | | 00: Input is high-z impedance 01: Auto RX-Detect, outputs test every 12 ms for 600 ms (50 times) then stops; termination is high-z until detection; once detected input termination is 50 Ω 10: Auto RX-Detect, outputs test every 12 ms until detection occurs; termination is high-z until detection; once detected input termination is 50 Ω 11: Input is 50 Ω Note: override RXDET Terminal. |
| | | 1:0 | Reserved | | | Set bits to 0. |
| 0x16 | CH1 - CHB_1 EQ | 7:0 | EQ Control | R/W | 0x2F | INB_1 EQ Control - total of 256 levels. See Table 5 . |
| 0x17 | CH1 - CHB_1 VOD | 7 | Short Circuit Protection | R/W | 0xAD | 1: Enable the short circuit protection 0: Disable the short circuit protection |
| | | 6 | MODE_SEL | | | 1: Gen 1/2, 0: SAS-3 and PCIe Gen 3 Note: override the MODE_B Terminal. |
| | | 5:3 | Reserved | | | Set bits to default value - 101. |
| | | 2:0 | VOD Control | | | OUTB_1 VOD Control 000: 0.7 V 001: 0.8 V 010: 0.9 V 011: 1.0 V 100: 1.1 V 101: 1.2 V (default) 110: 1.3 V 111: 1.4 V |

Table 12. SMBus Slave Mode Register Map (continued)

| Address | Register Name | Bit | Field | Type | Default | Description |
|---------|-----------------------------|-----|--------------------|------|---------|--|
| 0x18 | CH1 - CHB_1 DEM | 7 | RXDET STATUS | R | 0x02 | Observation bit for RXDET CH1 - CHB_1. 1: RX = detected 0: RX = not detected |
| | | 6:5 | MODE_DET STATUS | R | | Observation bit for MODE_DET CH1 - CHB_1. 00: GEN1 (2.5G data-rate) 01: GEN2 (5G data-rate) 11: GEN3 (8G+ data-rate) Note: Only functions when MODE_B Terminal = Automatic |
| | | 4:3 | Reserved | R/W | | Set bits to 0. |
| | | 2:0 | DEM Control | R/W | | OUTB_1 DEM Control 000: 0 dB 001: -1.5 dB 010: -3.5 dB (default) 011: -5 dB 100: -6 dB 101: -8 dB 110: -9 dB 111: -12 dB |
| 0x19 | CH1 - CHB_1 SD Threshold | 7:4 | Reserved | R/W | 0x00 | Set bits to 0. |
| | | 3:2 | IDLE tha | | | Assert threshold (1010 pattern 12 Gbps) 00 = 50 mVp-p (default) 01 = 40 mVp-p 10 = 75 mVp-p 11 = 58 mVp-p Note: override the SD_TH Terminal using 0x08[6]. |
| | | 1:0 | IDLE thd | | | De-assert threshold (1010 pattern 12 Gbps) 00 = 37 mVp-p (default) 01 = 22 mVp-p 10 = 55 mVp-p 11 = 45 mVp-p Note: override the SD_TH Terminal using 0x08[6]. |
| 0x1C | CH2 - CHB_2 IDLE, RXDET | 7:6 | Reserved | R/W | 0x00 | Set bits to 0. |
| | | 5 | IDLE_AUTO | | | 1: Automatic IDLE detect 0: Allow IDLE_SEL control in bit 4 Note: override IDLE control. |
| | | 4 | IDLE_SEL | | | 1: Output is MUTED (electrical idle) 0: Output is ON Note: override IDLE control. |
| | | 3:2 | RXDET | | | 00: Input is high-z impedance 01: Auto RX-Detect, outputs test every 12 ms for 600 ms (50 times) then stops; termination is high-z until detection; once detected input termination is 50 Ω 10: Auto RX-Detect, outputs test every 12 ms until detection occurs; termination is high-z until detection; once detected input termination is 50 Ω 11: Input is 50 Ω Note: override RXDET Terminal. |
| | | 1:0 | Reserved | | | Set bits to 0. |
| 0x1D | CH2 - CHB2 EQ | 7:0 | EQ Control | R/W | 0x2F | INB_2 EQ Control - total of 256 levels. See Table 5 . |

Table 12. SMBus Slave Mode Register Map (continued)

| Address | Register Name | Bit | Field | Type | Default | Description |
|---------|-----------------------------|-----|-----------------------------|------|---------|---|
| 0x1E | CH2 - CHB2 VOD | 7 | Short Circuit Protection | R/W | 0xAD | 1: Enable the short circuit protection 0: Disable the short circuit protection |
| | | 6 | MODE_SEL | | | 1: Gen 1/2, 0: SAS-3 and PCIe Gen 3 Note: override the MODE_B Terminal. |
| | | 5:3 | Reserved | | | Set bits to default value - 101. |
| | | 2:0 | VOD Control | | | OUTB_2 VOD Control 000: 0.7 V 001: 0.8 V 010: 0.9 V 011: 1.0 V 100: 1.1 V 101: 1.2 V (default) 110: 1.3 V 111: 1.4 V |
| 0x1F | CH2 - CHB_2 DEM | 7 | RXDET STATUS | R | 0x02 | Observation bit for RXDET CH2 - CHB_2. 1: RX = detected 0: RX = not detected |
| | | 6:5 | MODE_DET STATUS | R | | Observation bit for MODE_DET CH2 - CHB_2. 00: GEN1 (2.5G data-rate) 01: GEN2 (5G data-rate) 11: GEN3 (8G+ data-rate) Note: Only functions when MODE_B Terminal = Automatic |
| | | 4:3 | Reserved | R/W | | Set bits to 0. |
| | | 2:0 | DEM Control | R/W | | OUTB_2 DEM Control 000: 0 dB 001: -1.5 dB 010: -3.5 dB (default) 011: -5 dB 100: -6 dB 101: -8 dB 110: -9 dB 111: -12 dB |
| 0x20 | CH2 - CHB_2 SD Threshold | 7:4 | Reserved | R/W | 0x00 | Set bits to 0. |
| | | 3:2 | IDLE tha | | | Assert threshold (1010 pattern 12 Gbps) 00 = 50 mVp-p (default) 01 = 40 mVp-p 10 = 75 mVp-p 11 = 58 mVp-p Note: override the SD_TH Terminal using 0x08[6]. |
| | | 1:0 | IDLE thd | | | De-assert threshold (1010 pattern 12 Gbps) 00 = 37 mVp-p (default) 01 = 22 mVp-p 10 = 55 mVp-p 11 = 45 mVp-p Note: override the SD_TH Terminal using 0x08[6]. |

Table 12. SMBus Slave Mode Register Map (continued)

| Address | Register Name | Bit | Field | Type | Default | Description |
|---------|----------------------------|-----|-----------------------------|------|---------|--|
| 0x23 | CH3 - CHB_3 IDLE, RXDET | 7:6 | Reserved | R/W | 0x00 | Set bits to 0. |
| | | 5 | IDLE_AUTO | | | 1: Automatic IDLE detect 0: Allow IDLE_SEL control in bit 4 Note: override IDLE control. |
| | | 4 | IDLE_SEL | | | 1: Output is MUTED (electrical idle) 0: Output is ON Note: override IDLE control. |
| | | 3:2 | RXDET | | | 00: Input is high-z impedance 01: Auto RX-Detect, outputs test every 12 ms for 600 ms (50 times) then stops; termination is high-z until detection; once detected input termination is 50 Ω 10: Auto RX-Detect, outputs test every 12 ms until detection occurs; termination is high-z until detection; once detected input termination is 50 Ω 11: Input is 50 Ω Note: override RXDET Terminal. |
| | | 1:0 | Reserved | | | Set bits to 0. |
| 0x24 | CH3 - CHB_3 EQ | 7:0 | EQ Control | R/W | 0x2F | INB_3 EQ Control - total of 256 levels. See Table 5 . |
| 0x25 | CH3 - CHB_3 VOD | 7 | Short Circuit Protection | R/W | 0xAD | 1: Enable the short circuit protection 0: Disable the short circuit protection |
| | | 6 | MODE_SEL | | | 1: Gen 1/2, 0: SAS-3 and PCIe Gen 3 Note: override the MODE_B Terminal. |
| | | 5:3 | Reserved | | | Set bits to default value - 101. |
| | | 2:0 | VOD Control | | | OUTB_3 VOD Control 000: 0.7 V 001: 0.8 V 010: 0.9 V 011: 1.0 V 100: 1.1 V 101: 1.2 V (default) 110: 1.3 V 111: 1.4 V |
| 0x26 | CH3 - CHB_3 DEM | 7 | RXDET STATUS | R | 0x02 | Observation bit for RXDET CH3 - CHB_3. 1: RX = detected 0: RX = not detected |
| | | 6:5 | MODE_DET STATUS | R | | Observation bit for MODE_DET CH3 - CHB_3. 00: GEN1 (2.5G data-rate) 01: GEN2 (5G data-rate) 11: GEN3 (8G+ data-rate) Note: Only functions when MODE_B Terminal = Automatic |
| | | 4:3 | Reserved | R/W | | Set bits to 0. |
| | | 2:0 | DEM Control | R/W | | OUTB_3 DEM Control 000: 0 dB 001: -1.5 dB 010: -3.5 dB (default) 011: -5 dB 100: -6 dB 101: -8 dB 110: -9 dB 111: -12 dB |

Table 12. SMBus Slave Mode Register Map (continued)

| Address | Register Name | Bit | Field | Type | Default | Description |
|---------|-----------------------------|-----|-----------------------------|------|---------|--|
| 0x27 | CH3 - CHB_3 SD Threshold | 7:4 | Reserved | R/W | 0x00 | Set bits to 0. |
| | | 3:2 | IDLE tha | | | Assert threshold (1010 pattern 12 Gbps) 00 = 50 mVp-p (default) 01 = 40 mVp-p 10 = 75 mVp-p 11 = 58 mVp-p Note: override the SD_TH Terminal using 0x08[6]. |
| | | 1:0 | IDLE thd | | | De-assert threshold (1010 pattern 12 Gbps) 00 = 37 mVp-p (default) 01 = 22 mVp-p 10 = 55 mVp-p 11 = 45 mVp-p Note: override the SD_TH Terminal using 0x08[6]. |
| 0x28 | Signal Detect Control | 7:6 | Reserved | R/W | 0x0C | Set bits to 0. |
| | | 5:4 | High IDLE | | | Enable higher range of Signal Detect Thresholds [5]: CH0 - CH3 [4]: CH4 - CH7 |
| | | 3:2 | Fast IDLE | | | Enable Fast OOB response [3]: CH0 - CH3 [2]: CH4 - CH7 |
| | | 1:0 | Reduced SD Gain | | | Enable reduced Signal Detect Gain [1]: CH0 - CH3 [0]: CH4 - CH7 |
| 0x2B | CH4 - CHA_0 RXDET | 7:4 | Reserved | R/W | 0x00 | Set bits to 0. |
| | | 3:2 | RXDET | | | 00: Input is high-z impedance 01: Auto RX-Detect, outputs test every 12 ms for 600 ms (50 times) then stops; termination is high-z until detection; once detected input termination is 50 Ω 10: Auto RX-Detect, outputs test every 12 ms until detection occurs; termination is high-z until detection; once detected input termination is 50 Ω 11: Input is 50 Ω Note: override RXDET Terminal. |
| | | 1:0 | Reserved | | | Set bits to 0. |
| 0x2C | CH4 - CHA_0 EQ | 7:0 | EQ Control | R/W | 0x2F | INA_0 EQ Control - total of 4 levels. See Table 6 . |
| 0x2D | CH4 - CHA_0 VOD | 7 | Short Circuit Protection | R/W | 0xAD | 1: Enable the short circuit protection 0: Disable the short circuit protection |
| | | 6 | Reserved | | | Set bit to 0. |
| | | 5:3 | Reserved | | | Set bits to default value - 101. |
| | | 2:0 | VOD Control | | | OUTA_0 VOD Control 000: 0.65 001: 0.70 010: 0.78 011: 0.83 100: 0.88 101: 0.91 (Default) 110: 1.00 111: 1.05 (Recommended for SAS) |

Table 12. SMBus Slave Mode Register Map (continued)

| Address | Register Name | Bit | Field | Type | Default | Description |
|---------|-----------------------------|-----|-----------------------------|------|---------|--|
| 0x2E | CH4 - CHA_0 DEM | 7 | RXDET STATUS | R | 0x02 | Observation bit for RXDET CH4 - CHA_0. 1: RX = detected 0: RX = not detected |
| | | 6:5 | MODE_DET STATUS | R | | Observation bit for MODE_DET CH4 - CHA_0. 00: GEN1 (2.5G data-rate) 01: GEN2 (5G data-rate) 11: GEN3 (8G+ data-rate) Note: Only functions when MODE_B Terminal = Automatic |
| | | 4:3 | Reserved | R/W | | Set bits to 0. |
| | | 2:0 | DEM Control | R/W | | OUTA_0 DEM Control (010'b Default) This control does not provide a DEM function for A- Channel outputs. Based on system interoperability testing it is recommended to set these bits to 000'b for SAS and PCIe applications. |
| 0x2F | CH4 - CHA_0 SD Threshold | 7:4 | Reserved | R/W | 0x00 | Set bits to 0. |
| | | 3:2 | IDLE tha | | | Assert threshold (1010 pattern 12 Gbps) 00 = 50 mVp-p (default) 01 = 40 mVp-p 10 = 75 mVp-p 11 = 58 mVp-p Note: override the SD_TH Terminal using 0x08[6]. |
| | | 1:0 | IDLE thd | | | De-assert threshold (1010 pattern 12 Gbps) 00 = 37 mVp-p (default) 01 = 22 mVp-p 10 = 55 mVp-p 11 = 45 mVp-p Note: override the SD_TH Terminal using 0x08[6]. |
| 0x32 | CH5 - CHA_1 RXDET | 7:4 | Reserved | R/W | 0x00 | Set bits to 0. |
| | | 3:2 | RXDET | | | 00: Input is high-z impedance 01: Auto RX-Detect, outputs test every 12 ms for 600 ms (50 times) then stops; termination is high-z until detection; once detected input termination is 50 Ω 10: Auto RX-Detect, outputs test every 12 ms until detection occurs; termination is high-z until detection; once detected input termination is 50 Ω 11: Input is 50 Ω Note: override RXDET Terminal. |
| | | 1:0 | Reserved | | | Set bits to 0. |
| 0x33 | CH5 - CHA_1 EQ | 7:0 | EQ Control | R/W | 0x2F | INA_1 EQ Control - total of 4 levels. See Table 6 . |
| 0x34 | CH5 - CHA_1 VOD | 7 | Short Circuit Protection | R/W | 0xAD | 1: Enable the short circuit protection 0: Disable the short circuit protection |
| | | 6 | Reserved | | | Set bit to 0. |
| | | 5:3 | Reserved | | | Set bits to default value - 101. |
| | | 2:0 | VOD Control | | | OUTA_1 VOD Control 000: 0.65 001: 0.70 010: 0.78 011: 0.83 100: 0.88 101: 0.91 (Default) 110: 1.00 111: 1.05 (Recommended for SAS) |

Table 12. SMBus Slave Mode Register Map (continued)

| Address | Register Name | Bit | Field | Type | Default | Description |
|---------|-----------------------------|-----|-----------------------------|------|---------|--|
| 0x35 | CH5 - CHA1 DEM | 7 | RXDET STATUS | R | 0x02 | Observation bit for RXDET CH5 - CHA_1. 1: RX = detected 0: RX = not detected |
| | | 6:5 | MODE_DET STATUS | R | | Observation bit for MODE_DET CH5 - CHA_1. 00: GEN1 (2.5G data-rate) 01: GEN2 (5G data-rate) 11: GEN3 (8G+ data-rate) Note: Only functions when MODE_B Terminal = Automatic |
| | | 4:3 | Reserved | R/W | | Set bits to 0. |
| | | 2:0 | DEM Control | R/W | | OUTA_1 DEM Control (010'b Default) This control does not provide a DEM function for A- Channel outputs. Based on system interoperability testing it is recommended to set these bits to 000'b for SAS and PCIe applications. |
| 0x36 | CH5 - CHA_1 SD Threshold | 7:4 | Reserved | R/W | 0x00 | Set bits to 0. |
| | | 3:2 | IDLE tha | | | Assert threshold (1010 pattern 12 Gbps) 00 = 50 mVp-p (default) 01 = 40 mVp-p 10 = 75 mVp-p 11 = 58 mVp-p Note: override the SD_TH Terminal using 0x08[6]. |
| | | 1:0 | IDLE thd | | | De-assert threshold (1010 pattern 12 Gbps) 00 = 37 mVp-p (default) 01 = 22 mVp-p 10 = 55 mVp-p 11 = 45 mVp-p Note: override the SD_TH Terminal using 0x08[6]. |
| 0x39 | CH6 - CHA_2 RXDET | 7:4 | Reserved | R/W | 0x00 | Set bits to 0. |
| | | 3:2 | RXDET | | | 00: Input is high-z impedance 01: Auto RX-Detect, outputs test every 12 ms for 600 ms (50 times) then stops; termination is high-z until detection; once detected input termination is 50 Ω 10: Auto RX-Detect, outputs test every 12 ms until detection occurs; termination is high-z until detection; once detected input termination is 50 Ω 11: Input is 50 Ω Note: override RXDET Terminal. |
| | | 1:0 | Reserved | | | Set bits to 0. |
| 0x3A | CH6 - CHA_2 EQ | 7:0 | EQ Control | R/W | 0x2F | INA_2 EQ Control - total of 4 levels. See Table 6 . |
| 0x3B | CH6 - CHA_2 VOD | 7 | Short Circuit Protection | R/W | 0xAD | 1: Enable the short circuit protection 0: Disable the short circuit protection |
| | | 6 | Reserved | | | set bit to 0. |
| | | 5:3 | Reserved | | | Set bits to default value - 101. |
| | | 2:0 | VOD Control | | | OUTA_2 VOD Control: VOD / VID Ratio 000: 0.65 001: 0.70 010: 0.78 011: 0.83 100: 0.88 101: 0.91 (Default) 110: 1.00 111: 1.05 (Recommended for SAS) |

Table 12. SMBus Slave Mode Register Map (continued)

| Address | Register Name | Bit | Field | Type | Default | Description |
|---------|-----------------------------|-----|-----------------------------|------|---------|--|
| 0x3C | CH6 - CHA_2 DEM | 7 | RXDET STATUS | R | 0x02 | Observation bit for RXDET CH6 - CHA_2. 1: RX = detected 0: RX = not detected |
| | | 6:5 | MODE_DET STATUS | R | | Observation bit for MODE_DET CH6 - CHA_2. 00: GEN1 (2.5G data-rate) 01: GEN2 (5G data-rate) 11: GEN3 (8G+ data-rate) Note: Only functions when MODE_B Terminal = Automatic |
| | | 4:3 | Reserved | R/W | | Set bits to 0. |
| | | 2:0 | DEM Control | R/W | | OUTA_2 DEM Control (010'b Default) This control does not provide a DEM function for A- Channel outputs. Based on system interoperability testing it is recommended to set these bits to 000'b for SAS and PCIe applications. |
| 0x3D | CH6 - CHA_2 SD Threshold | 7:4 | Reserved | R/W | 0x00 | Set bits to 0. |
| | | 3:2 | IDLE tha | | | Assert threshold (1010 pattern 12 Gbps) 00 = 50 mVp-p (default) 01 = 40 mVp-p 10 = 75 mVp-p 11 = 58 mVp-p Note: override the SD_TH Terminal using 0x08[6]. |
| | | 1:0 | IDLE thd | | | De-assert threshold (1010 pattern 12 Gbps) 00 = 37 mVp-p (default) 01 = 22 mVp-p 10 = 55 mVp-p 11 = 45 mVp-p Note: override the SD_TH Terminal using 0x08[6]. |
| 0x40 | CH7 - CHA_3 RXDET | 7:4 | Reserved | R/W | 0x00 | Set bits to 0. |
| | | 3:2 | RXDET | | | 00: Input is high-z impedance 01: Auto RX-Detect, outputs test every 12 ms for 600 ms (50 times) then stops; termination is high-z until detection; once detected input termination is 50 Ω 10: Auto RX-Detect, outputs test every 12 ms until detection occurs; termination is high-z until detection; once detected input termination is 50 Ω 11: Input is 50 Ω Note: override RXDET Terminal. |
| | | 1:0 | Reserved | | | Set bits to 0. |
| 0x41 | CH7 - CHA_3 EQ | 7:0 | EQ Control | R/W | 0x2F | INA_3 EQ Control - total of 4 levels. See Table 6 . |
| 0x42 | CH7 - CHA_3 VOD | 7 | Short Circuit Protection | R/W | 0xAD | 1: Enable the short circuit protection 0: Disable the short circuit protection |
| | | 6 | Reserved | | | Set bit to 0. |
| | | 5:3 | Reserved | | | Set bits to default value - 101. |
| | | 2:0 | VOD Control | | | OUTA_3 VOD Control: VOD / VID Ratio 000: 0.65 001: 0.70 010: 0.78 011: 0.83 100: 0.88 101: 0.91 (Default) 110: 1.00 111: 1.05 (Recommended for SAS) |

Table 12. SMBus Slave Mode Register Map (continued)

| Address | Register Name | Bit | Field | Type | Default | Description |
|---------|----------------------------|-----|--------------------|------|---------|--|
| 0x43 | CH7 - CHA3 DEM | 7 | RXDET STATUS | R | 0x02 | Observation bit for RXDET CH7 - CHA3. 1: RX = detected 0: RX = not detected |
| | | 6:5 | MODE_DET STATUS | R | | Observation bit for MODE_DET CH7 - CHA3. 00: GEN1 (2.5G data-rate) 01: GEN2 (5G data-rate) 11: GEN3 (8G+ data-rate) Note: Only functions when MODE_B Terminal = Automatic |
| | | 4:3 | Reserved | R/W | | Set bits to 0. |
| | | 2:0 | DEM Control | R/W | | OUTA_3 DEM Control (010'b Default) This control does not provide a DEM function for A- Channel outputs. Based on system interoperability testing it is recommended to set these bits to 000'b for SAS and PCIe applications. |
| 0x44 | CH7 - CHA3 SD Threshold | 7:4 | Reserved | R/W | 0x00 | Set bits to 0. |
| | | 3:2 | IDLE tha | | | Assert threshold (1010 pattern 12 Gbps) 00 = 50 mVp-p (default) 01 = 40 mVp-p 10 = 75 mVp-p 11 = 58 mVp-p Note: override the SD_TH Terminal using 0x08[6]. |
| | | 1:0 | IDLE thd | | | De-assert threshold (1010 pattern 12 Gbps) 00 = 37 mVp-p (default) 01 = 22 mVp-p 10 = 55 mVp-p 11 = 45 mVp-p Note: override the SD_TH Terminal using 0x08[6]. |
| 0x51 | Device ID | 7:5 | VERSION | R | 0x84 | 100'b |
| | | 4:0 | ID | | | 00100'b |

8 Applications and Implementation

8.1 Application Information

8.1.1 Signal Integrity in SAS-3 Applications

SAS-3 specifications have fully specified Rx-Tx training as a means to establish and optimize signal conditioning settings at the 12.0 Gbps data-rate. The DS125BR401A works to extend the reach possible by adding active linear equalization to the channel, boosting attenuated signals so that they can be more easily recovered at the SAS-3 Rx. The A-Channel outputs are specially designed to be transparent to TX FIR signaling passing this information critical for optimal link training to the SAS-3 Rx. The A-Channel device settings used in a SAS-3 environment are EQ = Level 4, DEMA1 = 1 and DEMA0 = 0 in Terminal mode or EQ = 03'h, VOD = 111'b, and DEM = 000'b in SMBus mode.

8.1.2 RX-Detect in SAS/SATA Applications

Unlike PCIe systems, SAS/SATA systems use a low speed Out-Of-Band or OOB communications sequence to detect and communicate between SAS Controllers/Expanders and target drives. This communication eliminates the need to detect for endpoints like PCIe. For SAS systems, it is recommended to tie the RXDET Terminal high. This will ensure any OOB sequences sent from the Controller/Expander will reach the target drive without any additional latency due to the termination detection sequence defined by PCIe.

8.1.3 Signal Integrity in PCIe Applications

When using the DS125BR401A in PCIe GEN-3 systems, there are specific signal integrity settings to ensure signal integrity margin. The settings were optimized by system bench testing. Please contact your field representative for more information regarding the testing completed to achieve these settings.

For tuning the in the downstream direction (from CPU to EP).

- EQB: use the guidelines outlined in [Table 5](#) and [Table 6](#).
- EQA: EQ = 11'b or EQA0 = 1.
- DEMB: Use the guidelines outlined in [Table 7](#).
- DEMA set to 000'b in SMBus Mode.
- VODB: use the guidelines outlined in [Table 7](#).
- VODA: SMBus = 111'b, Terminal Control: DEMA1=1, DEMA0 = 0

For tuning in the upstream direction (from EP to CPU).

- B-Channel:
 - EQ: use the guidelines outlined in [Table 5](#) and [Table 6](#).
 - DEM for trace lengths < 15in set to -3.5 dB
 - DEM for trace lengths > 15in set to -6 dB
 - VOD: Set to 900 mV
- A-Channel:
 - EQ = 11'b or EQA0 = 1.
 - DEM for trace lengths < 15in set to 000'b in SMBus Mode.
 - DEM for trace lengths > 15in set to 000'b in SMBus Mode.
 - VOD: SMBus = 111'b, Terminal Control: DEMA1=1, DEMA0 = 0

8.1.4 MODE operation with SMBus Registers

When in SMBus mode (Slave or Master), the MODE Terminal retains control of the output driver characteristics. In order to override this control function, Register 0x08[2] must be written with a "1". Writing this bit enables MODE control of each channel individually using the channel registers defined in [Table 12](#).

8.2 Typical Application

SAS-3 specifications have fully specified Rx-Tx training as a means to establish and optimize signal conditioning settings at the 12.0 Gbps data-rate. The DS125BR401A works to extend the reach possible by adding active linear equalization to the channel, boosting attenuated signals so that they can be more easily recovered at the SAS-3 Rx. The A-Channel outputs are specially designed to be transparent to TX FIR signaling passing this information critical for optimal link training to the SAS-3 Rx. The A-Channel device settings used in a SAS-3 environment are EQ = Level 4, DEMA1 = 1 and DEMA0 = 0 in Terminal mode or EQ = 03'h, VOD = 111'b, and DEM = 000'b in SMBus mode.

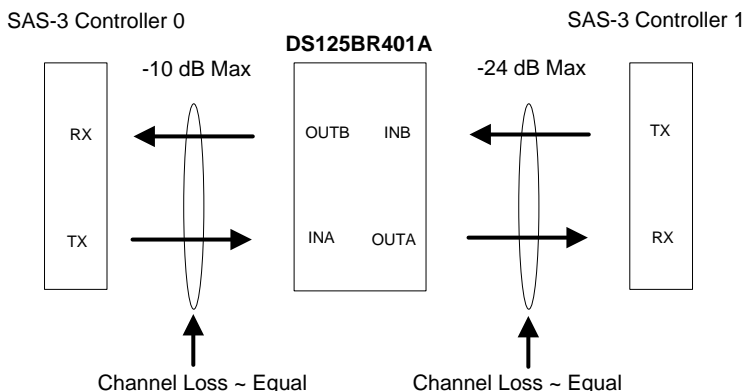

Figure 8. Typical System Configuration

8.2.1 Design Requirements

As with any high speed design, there are many factors which influence the overall performance, this section lists some critical areas for consideration and study.

- Limit the maximum losses according to [Figure 8](#).
- Utilize 100Ω impedance traces. Generally these are very loosely coupled to ease routing length differences.
- Place AC-coupling capacitors near to the receiver end of each channel segment to minimize reflections.
- The maximum body size for AC-coupling capacitors is 0402.
- Back-drill connector vias and signal vias to minimize stub length
- Use Reference plane vias to ensure a low inductance path for the return current.

8.2.2 Detailed Design Procedure

The DS125BR401A is designed to be placed at an offset location with respect to the overall channel attenuation, a maximum attenuation of 10 dB on the INA side and 22 dB on the INB side. The input channel segment with the lowest attenuation should always be connected to the INA port. This drives different design constraints and settings to the A-Channel and B-Channel sides. The A-Channel device settings used in a SAS-3 environment are EQ = Level 4, DEMA1 = 1 and DEMA0 = 0 in Terminal mode or EQ = 03'h, VOD = 111'b, and DEM = 000'b in SMBus mode. This setting has proven to give the best overall SAS-3 extension for all configurations tested. The B-Channel has a larger signal gain than the A-Channel and the capability to add even higher levels of CTLE if required. In even the longer channel configurations with attenuation on the B-Channel inputs of ~ 20 dB @ 6 GHz can recover a solid eye opening with EQB = Level 1, DEMA1 = FLOAT and DEMA0 = R in Terminal mode or EQ = 00'h, VOD = 101'b, and DEM = 000'b in SMBus mode.

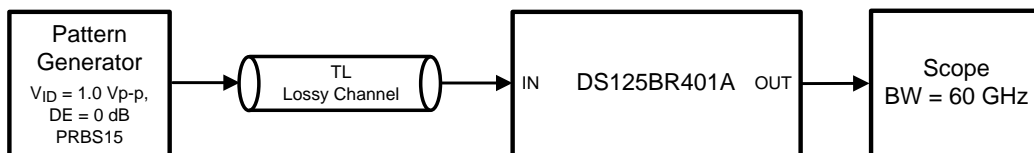

Figure 9. Test Setup Connections Diagram

Typical Application (continued)

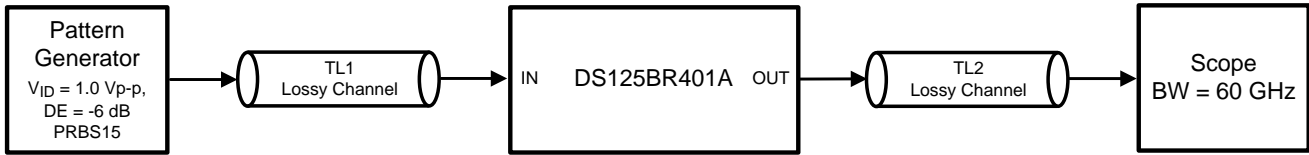
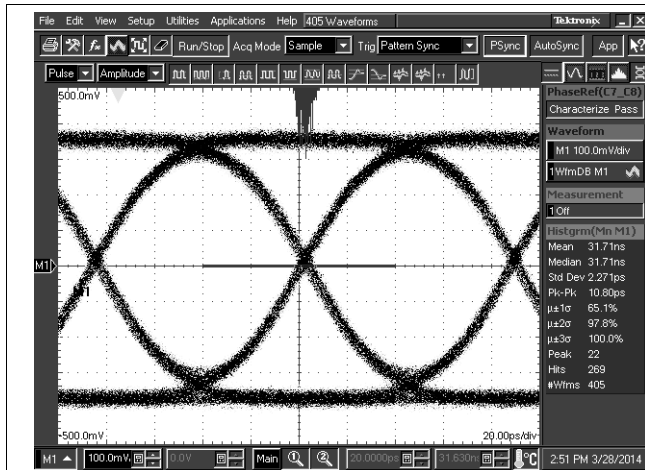
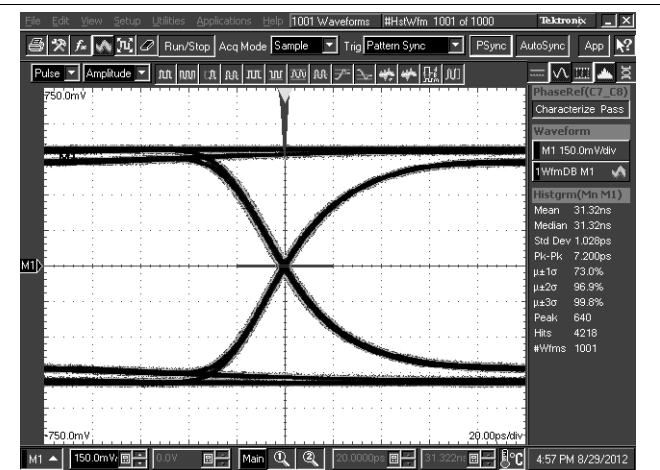

Figure 10. Test Setup Connections Diagram

8.2.3 Application Performance Plots



DS125BR401A settings: EQA[1:0] = 0, R = 01'h, DEMA[1:0] = 1, 0
Figure 11. TLine = 5 Inch 5-Mil FR4 Trace, 12 Gbps



DS125BR401A settings: EQB[1:0] = 0, F = 02'h, DEMB[1:0] = 0, 1
Figure 12. TLine = 10 Inch 5-Mil FR4 Trace, 6 Gbps

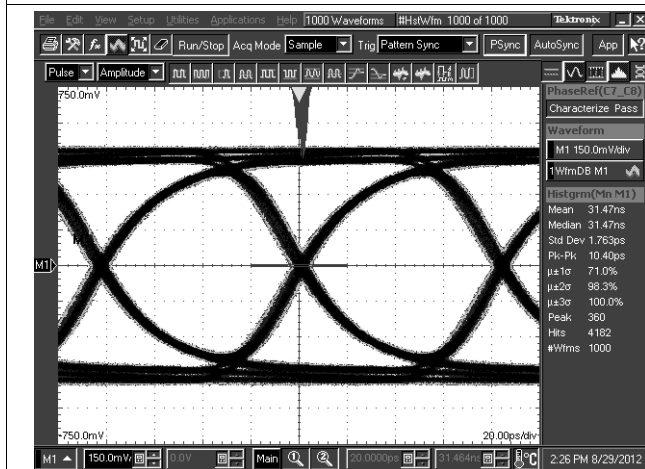

DS125BR401A settings: EQB[1:0] = 0, R = 01'h, DEMB[1:0] = 0, 1
Figure 13. TLine = 10 Inch 5-Mil FR4 Trace, 12 Gbps

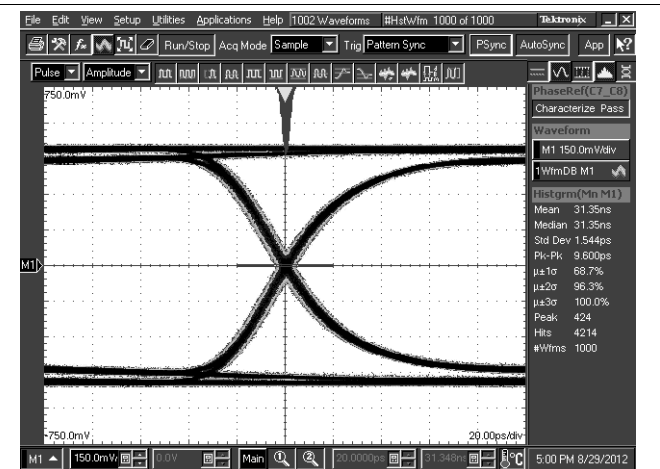

DS125BR401A settings: EQB[1:0] = 0, 1 = 03'h, DEMB[1:0] = 0, 1
Figure 14. TLine = 20 Inch 5-Mil FR4 Trace, 6 Gbps

Typical Application (continued)

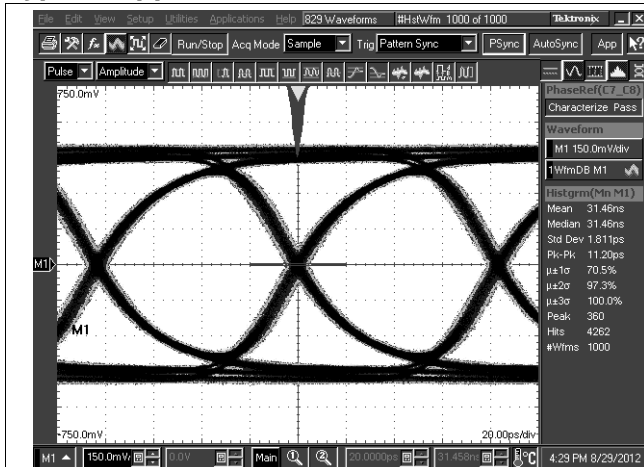

DS125BR401A settings: EQB[1:0] = 0, 1 = 03'h, DEMB[1:0] = 0, 1
Figure 15. T1 = 20 Inch 5-Mil FR4 Trace, 12 Gbps

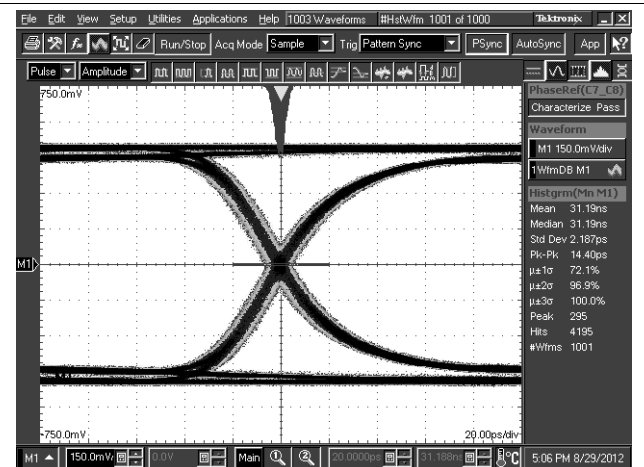

DS125BR401A settings: EQB[1:0] = R, 0 = 07'h, DEMB[1:0] = 0, 1
Figure 16. TLine = 30 Inch 5-Mil FR4 Trace, 6 Gbps

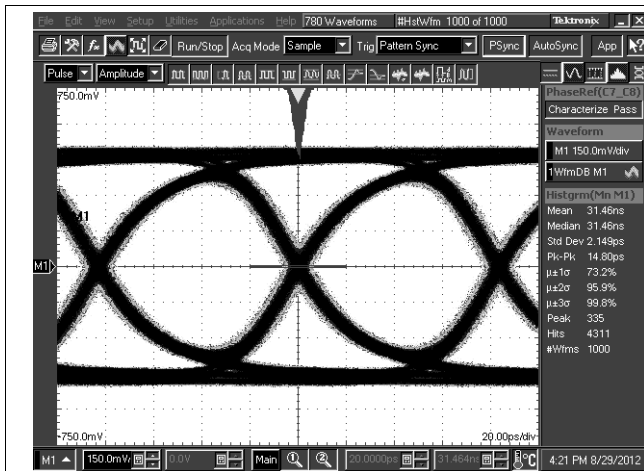

DS125BR401A settings: EQB[1:0] = R, 0 = 07'h, DEMB[1:0] = 0, 1
Figure 17. T1 = 30 Inch 5-Mil FR4 Trace, 12 Gbps

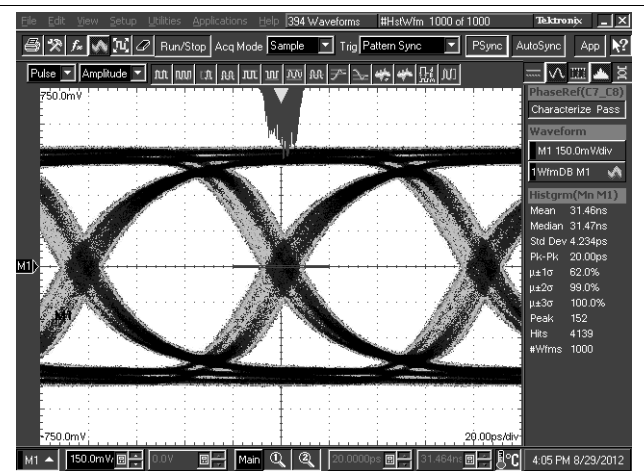

DS125BR401A settings: EQB[1:0] = R, 0 = 07'h, DEMB[1:0] = 0, 1
Figure 18. T11 = 5-Meter 30-Awg 100 Ohm Twin-Axial Cable, 12 Gbps

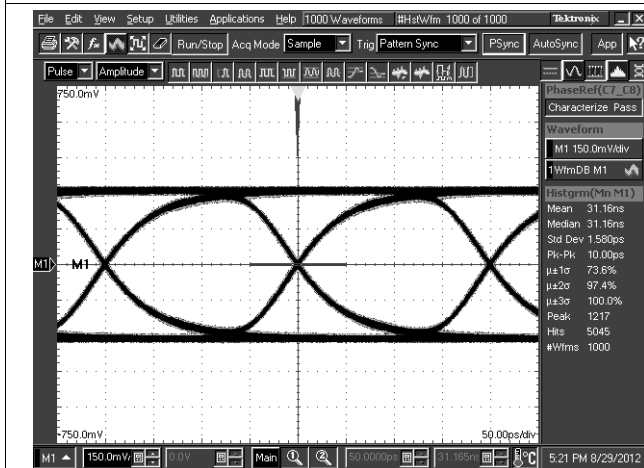

DS125BR401A settings: EQB[1:0] = 0, 1 = 03'h, DEMB[1:0] = R, 0
Figure 19. TLine1 = 20 Inch 5-Mil FR4 Trace, TLine2 = 10 Inch 5-Mil FR4 Trace, 5 Gbps

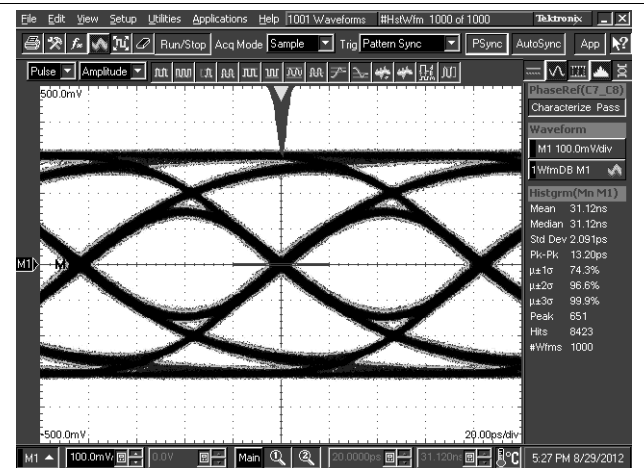

DS125BR401A settings: EQ[1:0] = R, 1 = 0F'h, DEM[1:0] = R, 0
Figure 20. TLine1 = 20 Inch 5-Mil FR4 Trace, TLine2 = 10 Inch 5-Mil FR4 Trace, 12 Gbps

9 Power Supply Recommendations

Two approaches are recommended to ensure that the DS125BR401A is provided with an adequate power supply. First, the supply (VDD) and ground (GND) Terminals should be connected to power planes routed on adjacent layers of the printed circuit board. The layer thickness of the dielectric should be minimized so that the V_{DD} and GND planes create a low inductance supply with distributed capacitance. Second, careful attention to supply bypassing through the proper use of bypass capacitors is required. A 0.1µF bypass capacitor should be connected to each V_{DD} Terminal such that the capacitor is placed as close as possible to the DS125BR401A. Smaller body size capacitors can help facilitate proper component placement. Additionally, capacitor with capacitance in the range of 1 µF to 10 µF should be incorporated in the power supply bypassing design as well. These capacitors can be either tantalum or an ultra-low ESR ceramic.

The DS125BR401A has an optional internal voltage regulator to provide the 2.5V supply to the device. In 3.3V mode operation, the VIN Terminal = 3.3V is used to supply power to the device. The internal regulator will provide the 2.5V to the VDD Terminals of the device and a 0.1µF cap is needed at each of the 5 VDD Terminals for power supply de-coupling (total capacitance should equal 0.5 µF). The VDD_SEL Terminal must be tied to GND to enable the internal regulator. In 2.5V mode operation, the VIN Terminal should be left open and 2.5V supply must be applied to the 5 VDD Terminals to power the device. The VDD_SEL Terminal must be left open (no connect) to disable the internal regulator.

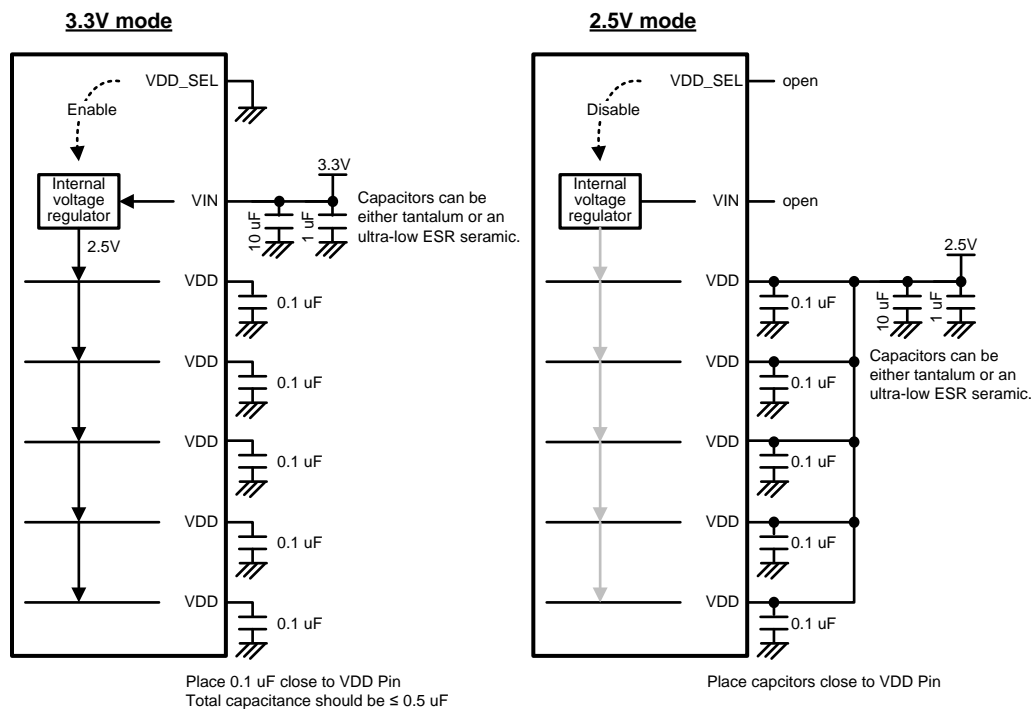

Figure 21. 3.3V or 2.5V Supply Connection Diagram

10 Layout

10.1 Layout Guidelines

The CML inputs and outputs have been optimized to work with interconnects using a controlled differential impedance of 100Ω. It is preferable to route differential lines exclusively on one layer of the board, particularly for the input traces. The use of vias should be avoided if possible. If vias must be used, they should be used sparingly and must be placed symmetrically for each side of a given differential pair. Whenever differential vias are used the layout must also provide for a low inductance path for the return currents as well. Route the differential signals away from other signals and noise sources on the printed circuit board. See AN-1187 “Leadless Leadframe Package (LLP) Application Report” (literature number [SNOA401](#)) for additional information on QFN (WQFN) packages.

10.2 Layout Example

To minimize the effects of crosstalk, a 5:1 ratio or greater should be maintained between inter-pair and intra-pair spacing.

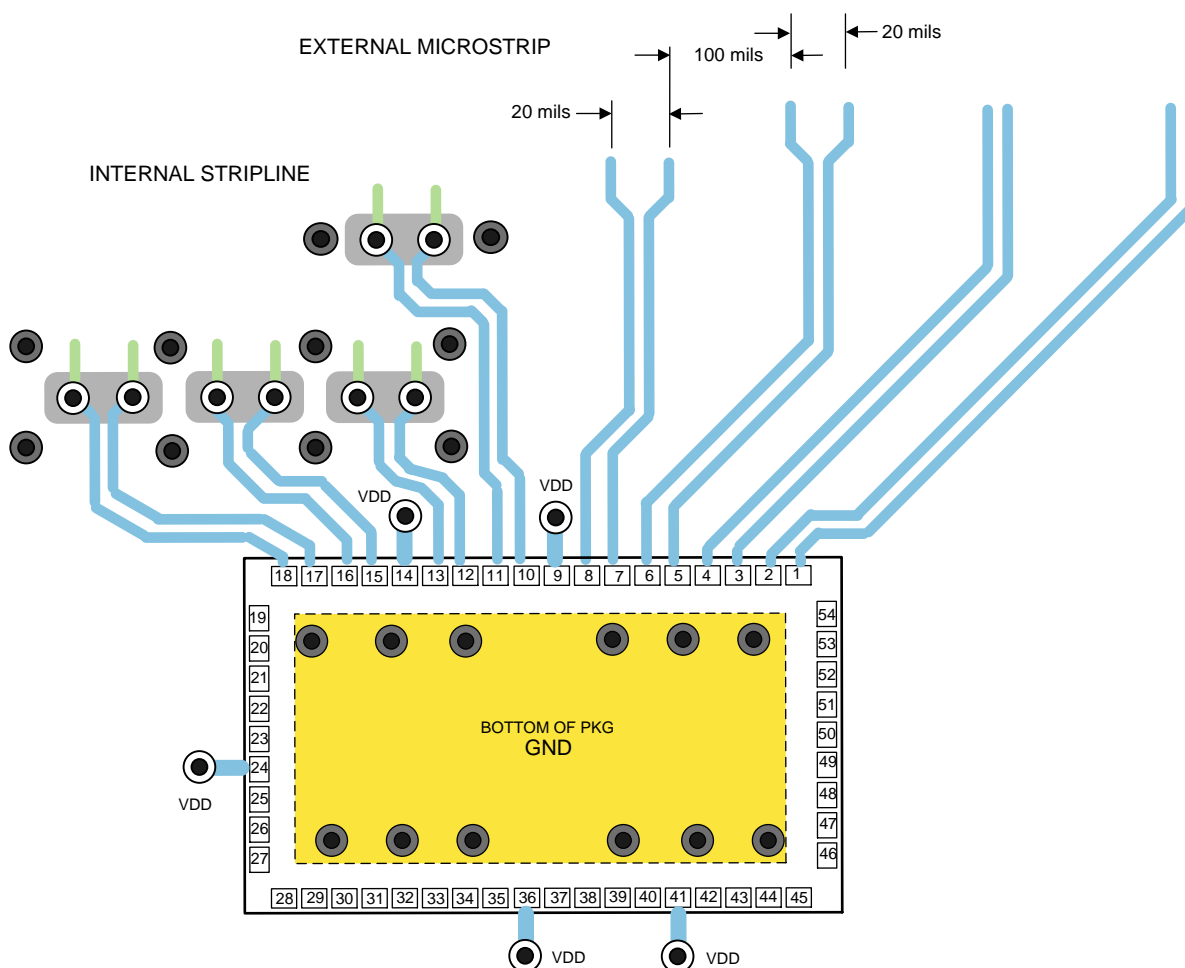

Figure 22. Typical Routing Options

The graphic shown above depicts different transmission line topologies which can be used in various combinations to achieve the optimal system performance. Impedance discontinuities at the differential via can be minimized or eliminated by increasing the swell around each hole and providing for a low inductance return current path. When the via structure is associated with thick backplane PCB, further optimization such as back drilling is often used to reduce the detrimental high frequency effects of stubs on the signal path.

11 Device and Documentation Support

11.1 Trademarks

All trademarks are the property of their respective owners.

11.2 Electrostatic Discharge Caution



These devices have limited built-in ESD protection. The leads should be shorted together or the device placed in conductive foam during storage or handling to prevent electrostatic damage to the MOS gates.

11.3 Glossary

[SLYZ022](#) — *TI Glossary*.

This glossary lists and explains terms, acronyms and definitions.

12 Mechanical, Packaging, and Orderable Information

The following pages include mechanical, packaging, and orderable information. This information is the most current data available for the designated devices. This data is subject to change without notice and revision of this document. For browser-based versions of this data sheet, refer to the left-hand navigation.

PACKAGING INFORMATION

| Orderable Device | Status (1) | Package Type | Package Drawing | Pins | Package Qty | Eco Plan (2) | Lead finish/ Ball material (6) | MSL Peak Temp (3) | Op Temp (°C) | Device Marking (4/5) | Samples |
|------------------|---------------|--------------|-----------------|------|-------------|-----------------|--------------------------------------|----------------------|--------------|-------------------------|-------------------------|
| DS125BR401ANJYR | ACTIVE | WQFN | NJY | 54 | 2000 | RoHS & Green | SN | Level-2-260C-1 YEAR | -40 to 85 | DS125BR401A | Samples |
| DS125BR401ANJYT | ACTIVE | WQFN | NJY | 54 | 250 | RoHS & Green | SN | Level-2-260C-1 YEAR | -40 to 85 | DS125BR401A | Samples |

(1) The marketing status values are defined as follows:

ACTIVE: Product device recommended for new designs.

LIFEBUY: TI has announced that the device will be discontinued, and a lifetime-buy period is in effect.

NRND: Not recommended for new designs. Device is in production to support existing customers, but TI does not recommend using this part in a new design.

PREVIEW: Device has been announced but is not in production. Samples may or may not be available.

OBSOLETE: TI has discontinued the production of the device.

(2) **RoHS:** TI defines "RoHS" to mean semiconductor products that are compliant with the current EU RoHS requirements for all 10 RoHS substances, including the requirement that RoHS substance do not exceed 0.1% by weight in homogeneous materials. Where designed to be soldered at high temperatures, "RoHS" products are suitable for use in specified lead-free processes. TI may reference these types of products as "Pb-Free".

RoHS Exempt: TI defines "RoHS Exempt" to mean products that contain lead but are compliant with EU RoHS pursuant to a specific EU RoHS exemption.

Green: TI defines "Green" to mean the content of Chlorine (Cl) and Bromine (Br) based flame retardants meet JS709B low halogen requirements of <=1000ppm threshold. Antimony trioxide based flame retardants must also meet the <=1000ppm threshold requirement.

(3) MSL, Peak Temp. - The Moisture Sensitivity Level rating according to the JEDEC industry standard classifications, and peak solder temperature.

(4) There may be additional marking, which relates to the logo, the lot trace code information, or the environmental category on the device.

(5) Multiple Device Markings will be inside parentheses. Only one Device Marking contained in parentheses and separated by a "~" will appear on a device. If a line is indented then it is a continuation of the previous line and the two combined represent the entire Device Marking for that device.

(6) Lead finish/Ball material - Orderable Devices may have multiple material finish options. Finish options are separated by a vertical ruled line. Lead finish/Ball material values may wrap to two lines if the finish value exceeds the maximum column width.

Important Information and Disclaimer:The information provided on this page represents TI's knowledge and belief as of the date that it is provided. TI bases its knowledge and belief on information provided by third parties, and makes no representation or warranty as to the accuracy of such information. Efforts are underway to better integrate information from third parties. TI has taken and continues to take reasonable steps to provide representative and accurate information but may not have conducted destructive testing or chemical analysis on incoming materials and chemicals. TI and TI suppliers consider certain information to be proprietary, and thus CAS numbers and other limited information may not be available for release.

In no event shall TI's liability arising out of such information exceed the total purchase price of the TI part(s) at issue in this document sold by TI to Customer on an annual basis.

TAPE AND REEL INFORMATION

QUADRANT ASSIGNMENTS FOR PIN 1 ORIENTATION IN TAPE

*All dimensions are nominal

| Device | Package Type | Package Drawing | Pins | SPQ | Reel Diameter (mm) | Reel Width W1 (mm) | A0 (mm) | B0 (mm) | K0 (mm) | P1 (mm) | W (mm) | Pin1 Quadrant |
|-----------------|--------------|-----------------|------|------|--------------------|--------------------|---------|---------|---------|---------|--------|---------------|
| DS125BR401ANJYR | WQFN | NJY | 54 | 2000 | 330.0 | 16.4 | 5.8 | 10.3 | 1.0 | 12.0 | 16.0 | Q1 |
| DS125BR401ANJYT | WQFN | NJY | 54 | 250 | 178.0 | 16.4 | 5.8 | 10.3 | 1.0 | 12.0 | 16.0 | Q1 |

TAPE AND REEL BOX DIMENSIONS

*All dimensions are nominal

| Device | Package Type | Package Drawing | Pins | SPQ | Length (mm) | Width (mm) | Height (mm) |
|-----------------|--------------|-----------------|------|------|-------------|------------|-------------|
| DS125BR401ANJYR | WQFN | NJY | 54 | 2000 | 356.0 | 356.0 | 35.0 |
| DS125BR401ANJYT | WQFN | NJY | 54 | 250 | 208.0 | 191.0 | 35.0 |



NJY0054A

WQFN

WQFN

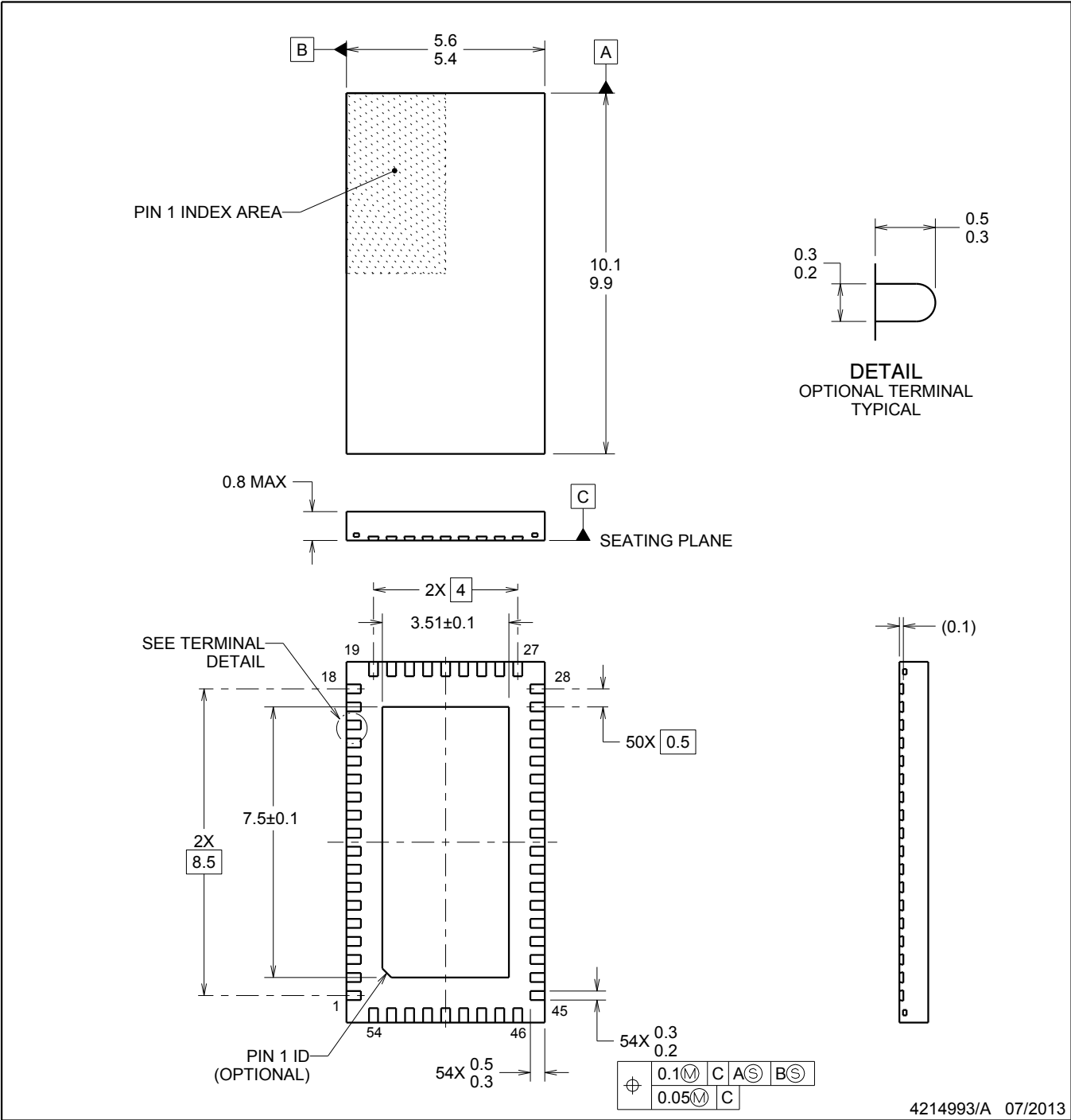

4214993/A 07/2013

NOTES:

- 1. All linear dimensions are in millimeters. Dimensions in parenthesis are for reference only. Dimensioning and tolerancing per ASME Y14.5M.
- 2. This drawing is subject to change without notice.
- 3. The package thermal pad must be soldered to the printed circuit board for thermal and mechanical performance.

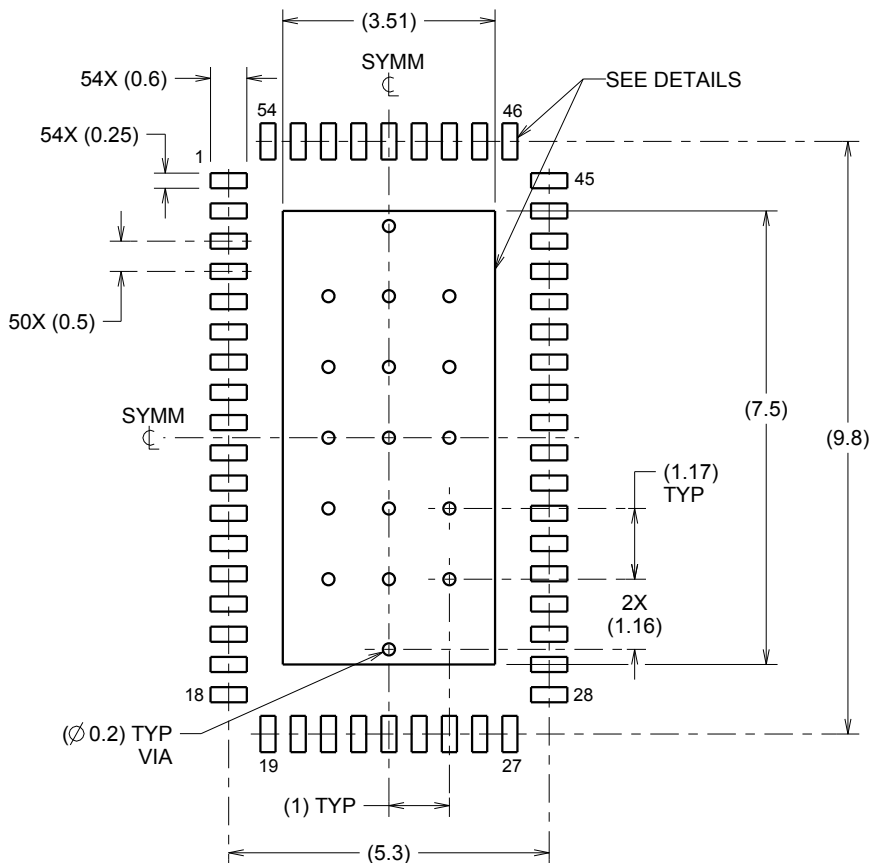

LAND PATTERN EXAMPLE
SCALE:8X

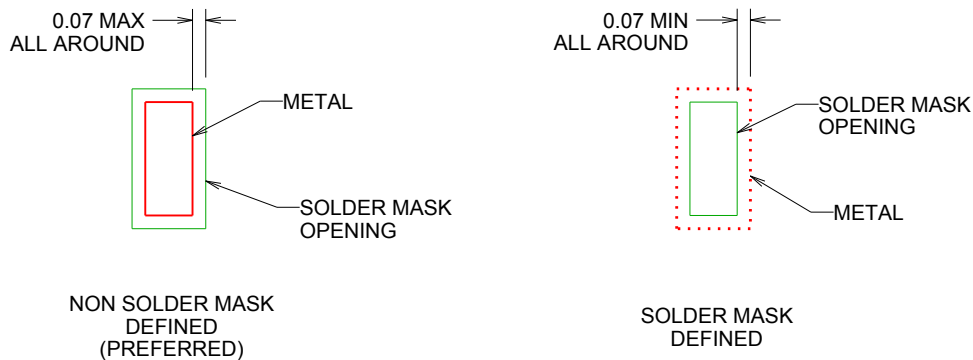

SOLDER MASK DETAILS

4214993/A 07/2013

NOTES: (continued)

4. This package is designed to be soldered to a thermal pad on the board. For more information, refer to QFN/SON PCB application note in literature No. SLUA271 (www.ti.com/lit/slue271).

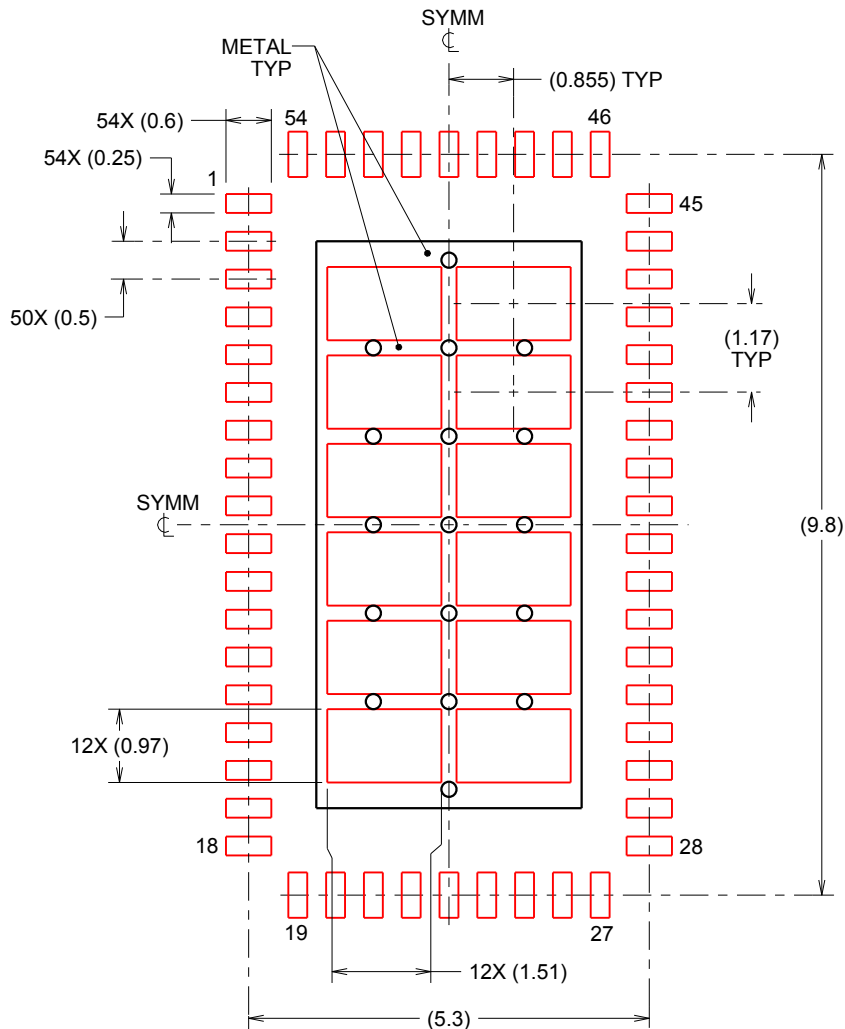

SOLDERPASTE EXAMPLE
 BASED ON 0.125mm THICK STENCIL

EXPOSED PAD
 67% PRINTED SOLDER COVERAGE BY AREA
 SCALE:10X

4214993/A 07/2013

NOTES: (continued)

5. Laser cutting apertures with trapezoidal walls and rounded corners may offer better paste release. IPC-7525 may have alternate design recommendations.

IMPORTANT NOTICE AND DISCLAIMER

TI PROVIDES TECHNICAL AND RELIABILITY DATA (INCLUDING DATA SHEETS), DESIGN RESOURCES (INCLUDING REFERENCE DESIGNS), APPLICATION OR OTHER DESIGN ADVICE, WEB TOOLS, SAFETY INFORMATION, AND OTHER RESOURCES "AS IS" AND WITH ALL FAULTS, AND DISCLAIMS ALL WARRANTIES, EXPRESS AND IMPLIED, INCLUDING WITHOUT LIMITATION ANY IMPLIED WARRANTIES OF MERCHANTABILITY, FITNESS FOR A PARTICULAR PURPOSE OR NON-INFRINGEMENT OF THIRD PARTY INTELLECTUAL PROPERTY RIGHTS.

These resources are intended for skilled developers designing with TI products. You are solely responsible for (1) selecting the appropriate TI products for your application, (2) designing, validating and testing your application, and (3) ensuring your application meets applicable standards, and any other safety, security, regulatory or other requirements.

These resources are subject to change without notice. TI grants you permission to use these resources only for development of an application that uses the TI products described in the resource. Other reproduction and display of these resources is prohibited. No license is granted to any other TI intellectual property right or to any third party intellectual property right. TI disclaims responsibility for, and you will fully indemnify TI and its representatives against, any claims, damages, costs, losses, and liabilities arising out of your use of these resources.

TI's products are provided subject to [TI's Terms of Sale](#) or other applicable terms available either on ti.com or provided in conjunction with such TI products. TI's provision of these resources does not expand or otherwise alter TI's applicable warranties or warranty disclaimers for TI products.

TI objects to and rejects any additional or different terms you may have proposed.

Mailing Address: Texas Instruments, Post Office Box 655303, Dallas, Texas 75265
Copyright © 2022, Texas Instruments Incorporated