

**DESCRIPTION**

The SRM™4010 Module is a complete solution for implementing very high efficiency Synchronous Rectification and eliminates many of the problems with self-driven approaches. The module connects to the transformer secondary of a Forward Converter to provide complete high current rectification at output voltages ranging from 5 volts down to 1.0 volt, in a thermally efficient surface mount package.

Rectification Efficiency as high as 95% is achieved by avoiding cross conduction. Dedicated Ics provide effective Gate drive of the ultra low Rds(on) MOSFETs used in the module. In conventional self-driven approaches, the MOSFET drive ends as soon as the power transformer finishes resetting. This causes increased losses as the duty cycle decreases. The SRM™4010 control circuitry drives either the Forward or the Catch MOSFET over virtually the entire duty cycle. Only a small prediction time, typically 100 ns, is needed to avoid cross conduction.

The SRM™4010 is designed to handle large sudden changes in duty cycle. This makes the module suitable for current mode control applications, with large load changes

where high bandwidth is needed. Proprietary prediction circuitry eliminates cross conduction for sudden large changes in pulse width. The module is self-powered from the transformer secondary winding and operates over a wide range of peak transformer voltages and PWM frequencies.

A 5-Volt Linear Regulator is also available as a power supply for other secondary side circuitry such as powering opto coupler feedback. In very low voltage applications where the peak transformer voltage is not high enough for powering the modules, secondary power can be provided to the regulator from an additional transformer winding.

The High Current Surface Mount Package has Low Inductance, and robust terminals for superior regulation and low noise susceptibility in high load current transients. The Module has an isolated base and is designed for direct PCB mounting with the terminals formed within the package. The base-plate of the module allows heat to be dissipated by the PCB etch, or a mechanical sink attachment through the PCB for higher power applications.

**KEY FEATURES**

- Easy to use Surface Mountable Solution for up to 40A
- Very High Rectification Efficiency at Output Voltages from 5V down to 1V
- Integrated Solution with few external parts saves Board Space
- Robust Package with Copper Base-Plate provides Effective Heat Distribution
- 5 Volt Linear Regulator available to power Secondary side Circuitry
- Suitable for converters that operate at light load
- Avoids problems with parallel operation that plague simple self-driven schemes
- Operates at PWM Frequencies ranging from 200 to 400KHz

**APPLICATIONS**

- High Current Isolated DC-DC Converters
- Distributed Power Architectures
- CPU Power Supply off 48VDC Bus

**PRODUCT HIGHLIGHT**

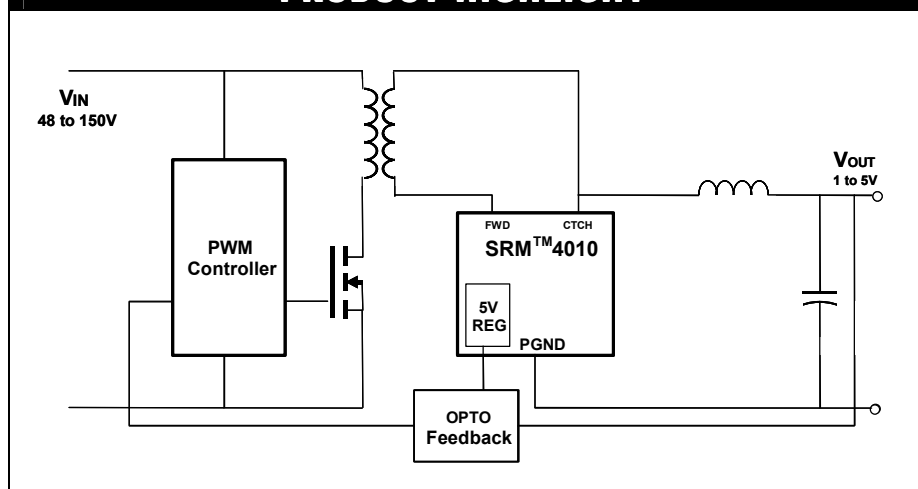

Figure 1

**PACKAGE**

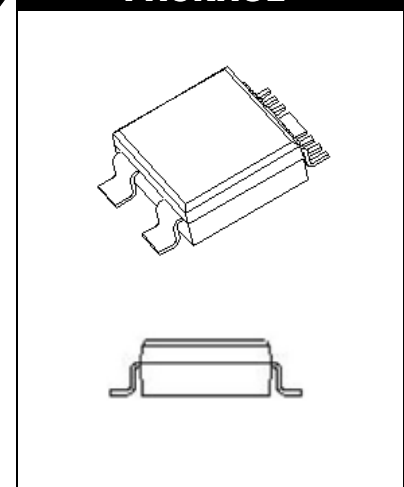

Figure 2



**FUNCTIONAL PIN DESCRIPTION**

Pin Number	Pin Name	Function and description
1	<b>CTCH</b>	This is the power MOSFET drain for the Catch device. It connects to the output inductor and the positive of the forward converter transformer secondary.
2	<b>FWD</b>	This is the power MOSFET Drain for the forward device. This pin connects to the negative of the forward converter transformer secondary.
3	<b>SGND</b>	The signal reference for external tailoring parts.
4	<b>REG<sub>IN</sub></b>	This is the input signal to the linear regulator. It can be used as an input in low output voltage applications where the peak voltage on the MOSFETs is not high enough to operate the regulator.
5	<b>REG<sub>OUT</sub></b>	5V regulator output. It is also available for use with feedback circuitry that is on the secondary side. This is useful in low voltage converters where the voltage is too low to operate optical couplers directly from the output.
6	<b>PGND</b>	This is the common of the power MOSFET synchronous rectifiers
7	<b>CDLY</b>	Pin 7 is used to ensure that the transformer can be reset during light load operation. To allow reset, the forward drive is inhibited for a time before the turn on of the Catch MOSFET Gate.
8	<b>CPDT</b>	Pin 8 is used for an external capacitor to tailor the prediction time for the Catch synchronous rectifier.
9	<b>SPD</b>	Pin 9 is used to tailor the module's ability to differentiate between valid turn off of the Catch MOSFET and ringing that can occur at light load.

**PACKAGE PIN OUT**

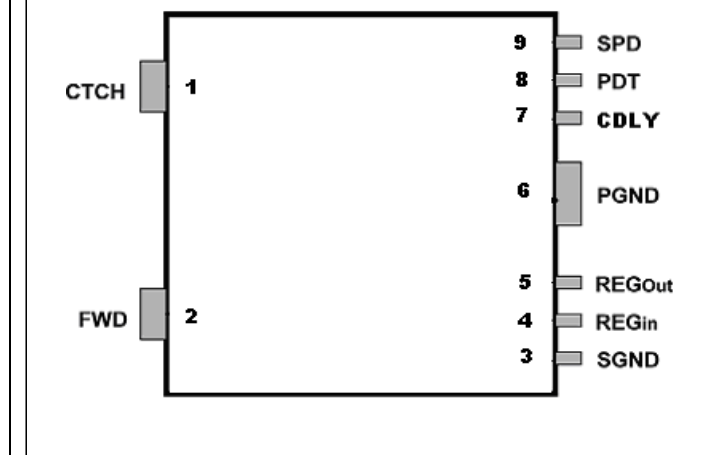

Figure 3

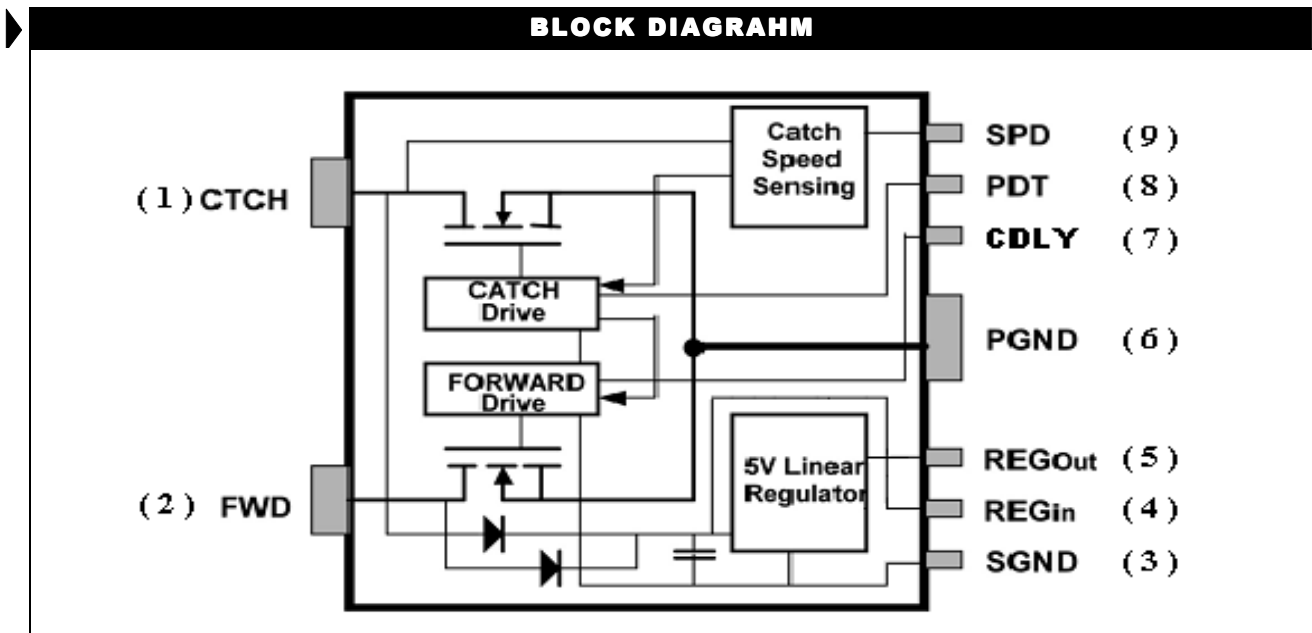

Figure 4

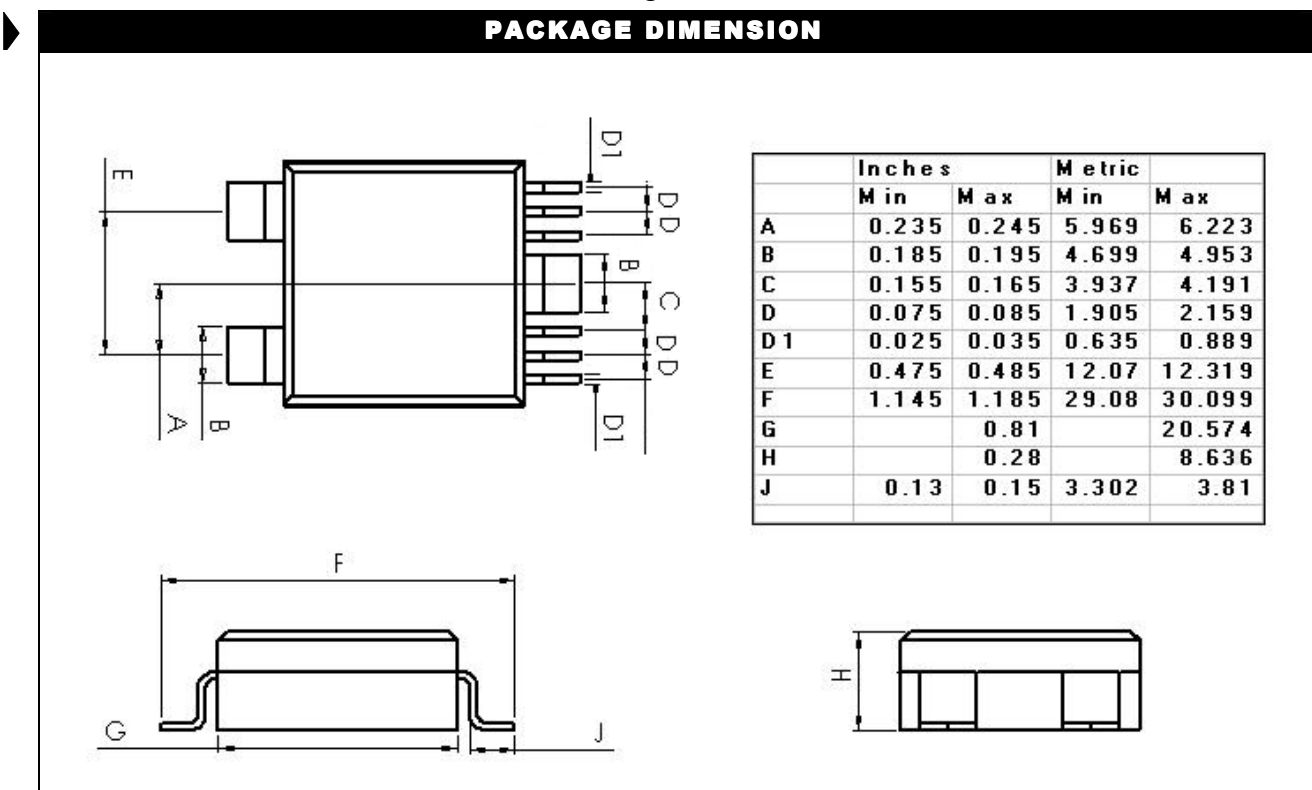

Figure 5

**THEORY OF OPERATION**

**General Description**

The SRM™4010 contains two power MOSFETs that act as low loss rectifiers. The proprietary control ICs operate these MOSFETs as synchronous rectifiers in circuit that maximizes efficiency and eliminates cross conduction.

The SRM™4010 has an internal 5 volt linear regulator that powers the internal control circuitry and can also provide a power source that can be used for external control circuitry. This is especially useful in low voltage outputs where the output is not high enough to power the secondary-side control directly for the output

**Continuous/Heavy Load Operation**

Continuous conduction is the mode of operation where there is always current flowing in the output inductor. This is the normal mode of operation in most forward converters in medium to high power applications.

During the conduction period (on-time) of the primary-side Switch (usually a MOSFET), the Catch MOSFET in the module is off and the current is flowing from the transformer to the output inductor, output capacitor and the load. The load current returns though the forward MOSFET to the negative secondary terminal of the power transformer.

The transformer voltage applied to the Catch MOSFET in the module must be below the 20V maximum rating in this mode of operation. As the primary-side switch turns off, the transformer current goes to zero and the voltage on Pin 1 of the module falls to zero driven by the current stored in the output inductor. In this mode, the current is carried through the Catch MOSFET body diode momentarily, then the MOSFET is turned on allowing reduced forward voltage drop. The time of body diode conduction is very short, typically less than 50 nS. The transformer voltage on Pin 2 goes positive, driven by the transformer magnetizing current. This allows the transformer to reset, keeping volt-second balance on the core

Since a transformer cannot support dc voltage, the area of the ON time and the OFF time are equal. After reset the transformer voltage actually changes sign causing a slight forward bias of the body diode in the forward MOSFET. This voltage is typically -0.5 volts, however, since there is almost no current flowing during this time, there is no significant power loss. When the primary-side switch turns on, the internal control circuitry turns off the Catch MOSFET slightly before the rise of the voltage and also turns on the forward MOSFET

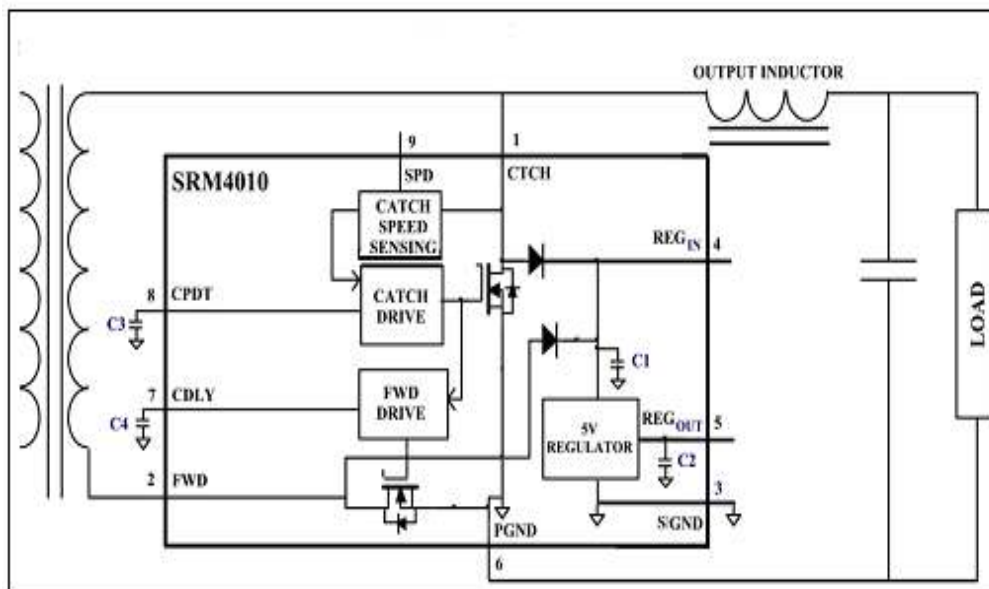

**Figure 6**  
**SRM™4010 Forward Converter Block Diagram**

### Discontinuous/Light Load Operation

The SRM™4010 is well behaved in light mode operation, which is also called discontinuous conduction mode. In this mode of operation, the inductor current goes to zero. During this mode, there are times when both MOSFETS in the module are OFF. Discontinuous operation can be at the normal switching frequency or in the event the converter operates in a skipped cycle mode.

The module senses a valid turn-on of the primary MOSFET by the voltage rise on the Catch MOSFET Drain (Pin1). In the case of light mode operation, there is an extended period where the primary-side power switch is OFF. During this period of time, the voltage on the Drain can be ringing. The SRM™4010 power module can distinguish between a voltage rise due to the primary MOSFET being turned ON and ringing. The distinguishing characteristic between the two cases is the speed of the voltage rise. A voltage rise driven by the turn on of the primary MOSFET is fast compared to ringing. The  $dV/dT$  threshold for sensing a valid turn on can be adjusted by changing the bias on the SPD pin (pin9). Biasing this pin to +5v through a resistor will make the normal turn on respond to a slower transition. This could be necessary if a turn on snubber is used to slow the normal turn on speed. Biasing this pin to the REGOUT through a resistor makes the controller less sensitive.

### Current Mode Control and High Bandwidth

**Converters** The SRM™4010 accommodates current mode or voltage mode control. The module can tolerate large step changes in pulse width that can occur in high bandwidth control loops without having cross conduction of the rectifying MOSFETS.

For best efficiency, the current mode control should have adequate ramp compensation to prevent cycle by cycle instabilities where the pulse width is changing between alternating cycles. This stabilization is accomplished in the current mode control by adding in a compensating ramp to the current feedback signal.

In the case of a sudden increase in load or drop in input voltage, current mode control allows rapid increases in pulse width to correct for the resulting output change. The Catch MOSFET drive is momentarily reduced before the end of the next OFF time when there is a sudden increase in ON time of the primary Switch. The ON time then recovers to the normal prediction time over a number of cycles. This technique prevents problems of the Catch MOSFET being ON when it needs to be OFF, yet maintains good efficiency in the steady state condition.

### Internal 5V Regulator

The internal regulator is a linear regulator that requires at least 0.8 volts of headroom. The voltage on pin 4 REG<sub>IN</sub> should be at least 5.8 volts at the lowest point of the ripple. To achieve the required 5.8 volts of input to the regulator, the peak transformer voltage during either reset or the forward mode needs to be at least 6.8 volts. If an external load is added to the REG<sub>IN</sub> pin or the REG<sub>OUT</sub> pin, care must be exercised to make sure that a minimum voltage of 6.8 volts is maintained on pin 4. Externally injected voltage must be diode isolated to prevent loading of the internal diodes.

In applications where the peak transformer voltage is below the minimum needed to provide proper regulator input voltage, power can be supplied to the regulator input from an additional secondary winding through a diode and a series resistor. The peak voltage fed to the REG<sub>IN</sub> pin should be below the absolute maximum voltage of 20 volts. Voltages this high are undesirable however since there is a power loss associated with the voltage drop in the regulator.

### Converter Switching Frequency

The converter switching frequency can range from 200 KHz to 400 KHz. From a SRM™4010 module standpoint, there are limits on the maximum ON time and maximum OFF time. This is due to internal timing used for prediction. The timing circuitry will saturate at low frequency if the times exceed the capability of the timing circuits. At the high frequency end, the same timing is less accurate



### External Control Pins

There are 3 external control pins for tailoring the module operation to the characteristics of the power converter. These external pins provide maximum flexibility in using the module in converter with different characteristics

#### SPD- Module Pin 9

Pin 9 is used to tailor the module's ability to differentiate between valid turn on of the Catch MOSFET and ringing that can occur at light load.

For the module to properly operate there has to be a difference in the ringing time and the normal turn off transitions from the primary power switch turning OFF. In some cases it is necessary to change the resonance behavior of the power converter to provide more difference between ringing that occurs at light load conditions and the turn off at higher loads where consistent triggering of the module synchronous operation is important. This can be done by adding additional capacitance in parallel with the catch MOSFET in the module. This is from pins 1 to 6. The capacitance will reduce the speed of ringing transitions and provide more difference between turn off transitions from the primary switch turning OFF and those caused by ringing. Ringing that does not cross the 4.3 volt to 1.7 volt transition does not cause the sensing to be triggered.

Pin 9 is normally open. This sets the boundary for normal turn on at 6nS for the drain voltage to fall from 4.3 volts to 1.7 volts. Fall times between the thresholds that are faster than 6nS are interpreted as valid turn ON's caused by the primary being switched off. Transitions slower than 6nS are interpreted as ringing, which occurs in light load discontinuous operation. In the light load case, the Catch MOSFET is not turned on. Biasing pin 9 can change the speed of this threshold. If the controller is not sensing normal turn off from the primary, biasing Pin 9 to ground through a resistor can make the controller respond to faster transitions. If the controller is responding falsely to ringing in a discontinuous mode or skip cycle operation, the controller can be made to reject slower ringing by biasing Pin 9 through a resistor to the +5V REGOUT at Pin 5.

#### CPDT- Module Pin 8

This pin is used for an external capacitor to tailor the prediction time for the Catch synchronous rectifier. The external capacitor connects between pin 8 and SGND. This is the time between the rise of the Catch Drain voltage and the rise of the Catch Gate voltage. Typical values of this capacitor are 0 to 47 pF. Increasing the capacitance increases the prediction time delay. This time should be made as short as possible without causing frequent reductions in the enhancement time due to converter pulse width jitter. It is often useful to start with about 22 pF of

capacitance on pin 8 for initial debug. This can later be reduced for more optimal efficiency after the converter is working.

#### CDLY- Module Pin 7

This pin is used to ensure that the transformer can be reset during light load operation. To allow reset, the forward drive is inhibited for a time from the turn on of the Catch MOSFET Gate. A capacitor to ground sets the time duration where the forward MOSFET Gate drive is disabled. Increasing the capacitor increases the hold off time. The proper value of this capacitor is a function of the amount of time needed to ensure the transformer is reset. If the time is made too long, it inhibits enhancement of the forward MOSFET during times when it is carrying load current. If the time is made too short, there is a problem with allowing the power transformer to reset properly during light load operation.

### Layout Guidelines

The SRM™4010 is designed to simplify the PCB layout. The SGND is common to the PGND inside the device. SGND should be kept separate from the PGND unless the PGND can be made large in area to have small inductance. The SGND is the intended reference for the external tailoring parts. The baseplate can be made common with the PGND plane and used to spread heat. One technique that works well is to have the PGND plane on the layer immediately under the SRM™4010 and flood the plane around the leads 4, 5, 7, 8 and 9. The plane would connect to pins 3 and 6. Surface mount parts can then be used for the added parts on 7, 8 and 9.

Care must be given to the resistance of traces on the output interconnects. It is easy to have trace losses that are equal to or higher than the conduction losses in the module.

### Demo Board

A dedicated fully operational board is available to demonstrate the operation of the SRM™4010. The board contains a standard commercially available PWM controller. The board is designed to operate at 48v input and 3.3v output levels. The inductor is a pair of surface mount transformers at a 9:2 turns ratio, which gives a 10v secondary voltage swing from a 48v input. These inductors are suitable for low volume sampling and development. Volume production using optimized planar inductors with the SRM™4010 will have a typical converter efficiency 1% - 2% higher than the demonstration board's efficiency.

**APPLICATION INFORMATION**

**Typical Forward Converter**

Figure 7 shows a typical schematic for using the SRM™4010 in an isolated Forward converter. The 5 volt output from the internal linear regulator is used to provide power for the isolated optical feedback. Using the TLV431 outputs as low as 1.25 volts can be regulated with the opto-coupler feedback.

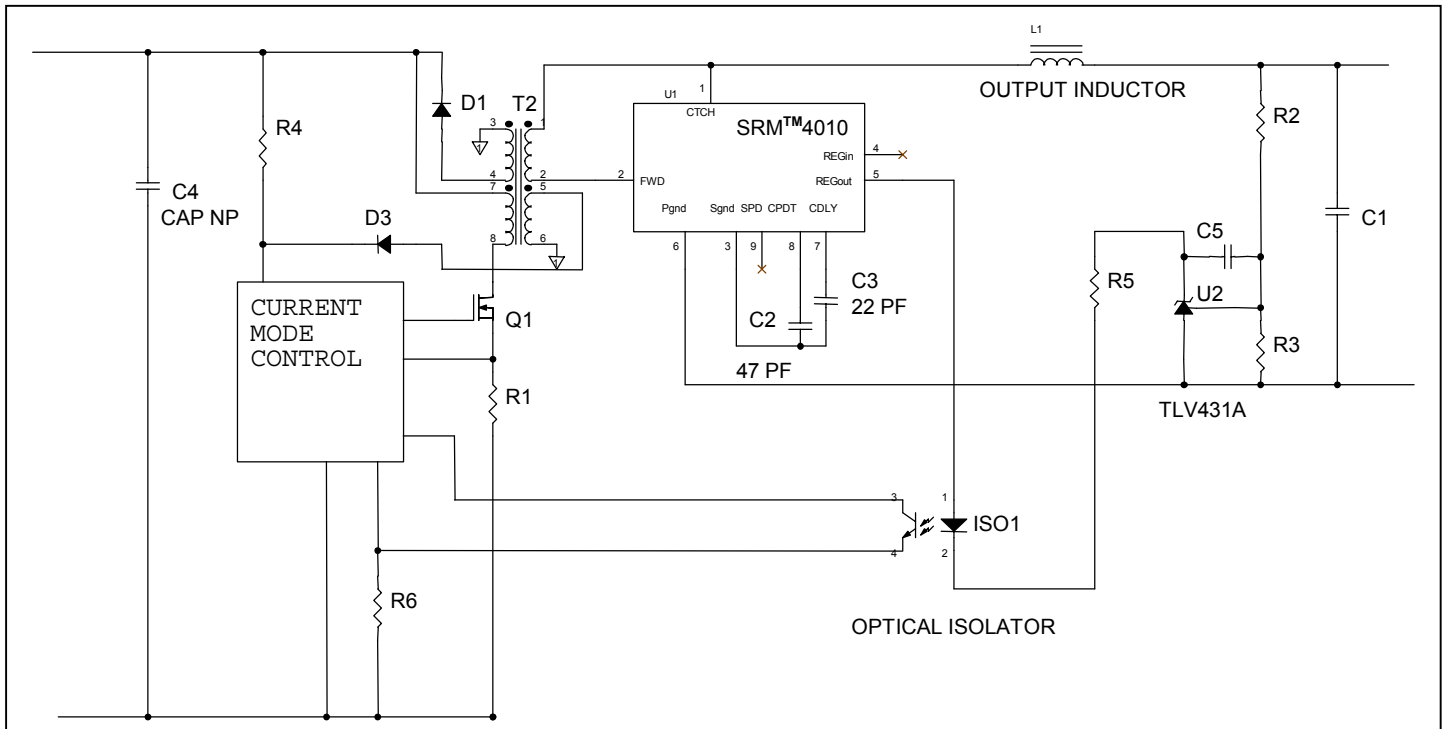

**Figure 7**  
**SRM™4010 In a typical 1.25 To 3 Volt output Isolated Power Converter**



### Very Low Output Voltage Converter

For voltages below 1.25 volts, R3 can be moved to REG<sub>OUT</sub> to allow regulation below the 1.24 volt reference as shown in Figure 8. In this case the REG<sub>OUT</sub> is used to feed current into the TLV431's summing node. This causes the output to regulate at a voltage lower than the reference. There are other variations of closing the feedback loop that can be used, but in many cases the availability of the REG<sub>OUT</sub> makes the task easier.

In applications where the peak transformer voltage is less than about 8 volts, power can be supplied to the module through an additional winding on the power transformer. This requires only the additional winding and one diode. This is illustrated in figure 8 with transformer winding T1E and D4.

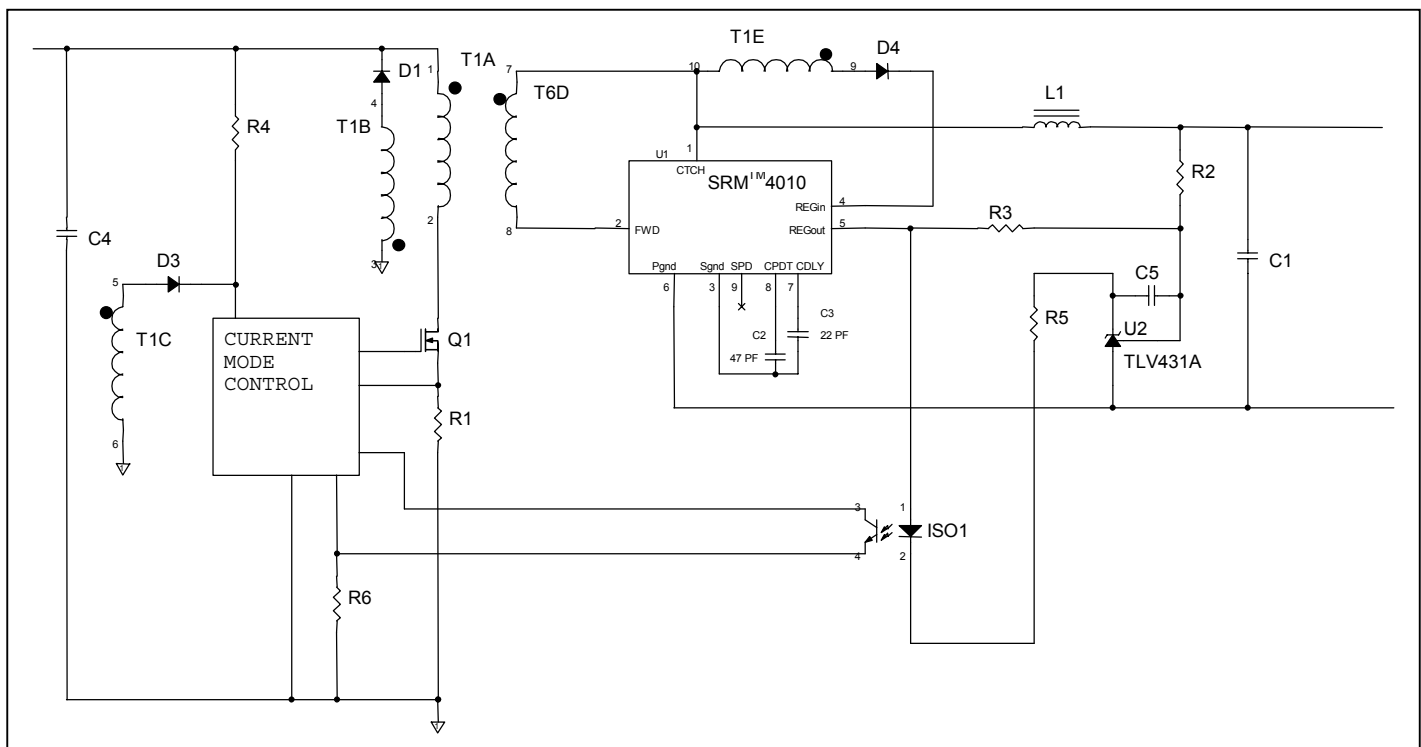

Figure 8

SRM™4010 Configured for outputs below 1.25 Volts

### Multi-Output Applications

The module can be used in multiple output converters also. As in any converter with multiple outputs from one power converter, there are limitations on the range of load variations for good regulation.

Below is a two output application where one output is regulated and the other tracks based on the transformer turns ratio. As long as both sections are operating in the continuous conduction mode over the required load range, this approach actually has very good cross regulation. The low voltage drop in the module helps to improve cross regulation.

The dual output approach can be followed by a non-isolated buck power converter to improve regulation if needed. This still allows the two outputs to have isolated grounds. The switching regulator can be an integrated regulator with the power switches internal to the device or even a synchronous rectifier approach. The secondary winding rectifiers also can be implemented with Schottkys. For the cases where the power level is lower for the secondary output, this can be combined with a simple linear regulator.

### Hot Swap and Redundant Converter Applications

The self-driven approach to synchronous rectification has serious problems when converters are operated in parallel. This is desirable in many applications to improve system reliability or to allow higher output current than is practical with a single converter or in some cases to power a load from multiple power inputs. Forward converters using the SRM™4010 are well behaved when they are connected to other power converter outputs.

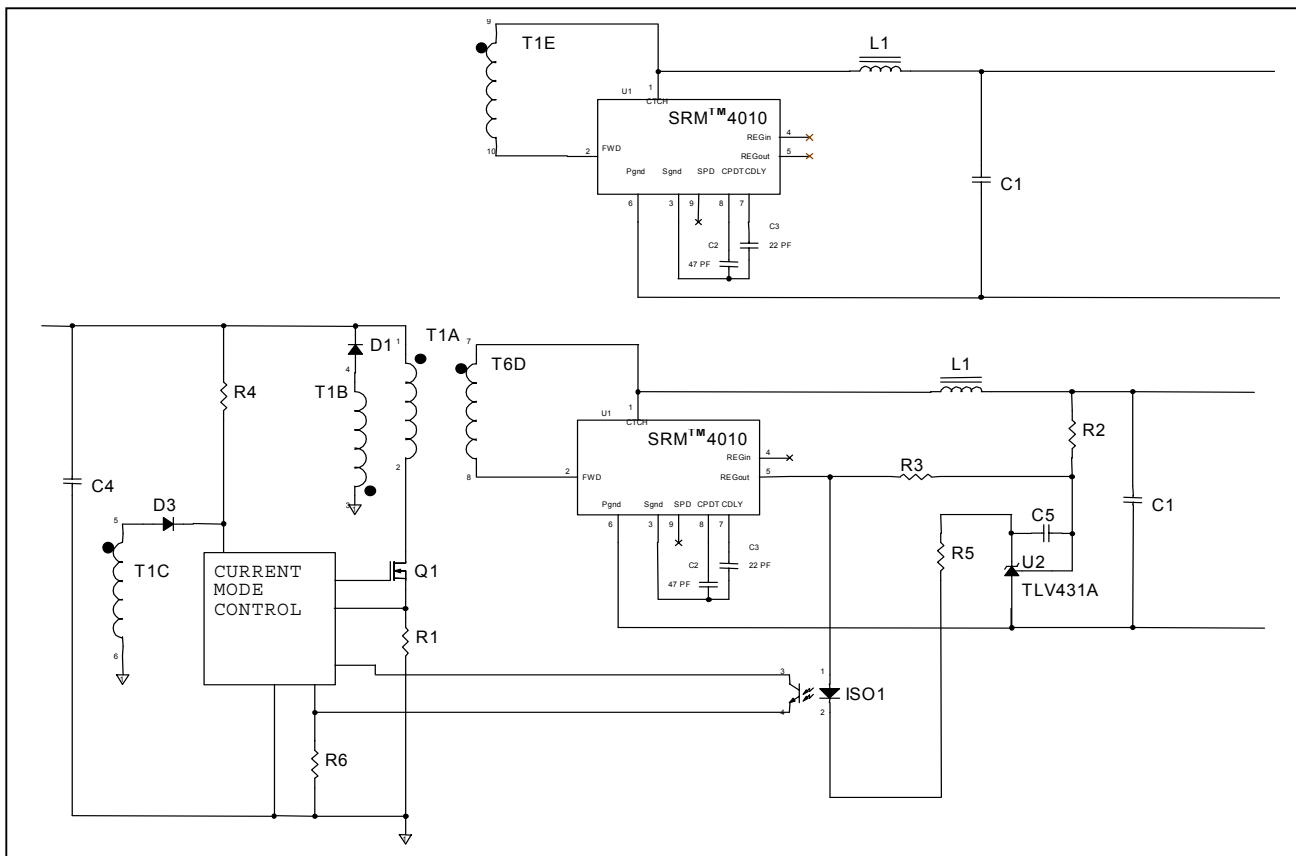

Figure 9  
SRM™4010 Multiple Output Configuration