

USB 5V, 2.5A Output, 35V Input with Cable Drop Compensation

DESCRIPTION

Demonstration circuit 1893A is a USB 5V, 2.5A output, 35V input buck with cable drop compensation featuring the [LT[®]3697](#). The LT3697 is a step-down switching regulator designed to power 5V USB applications.

A precise output voltage and programmable cable drop compensation maintain accurate 5V regulation at the USB socket at the end of a long cable. The circuit was designed to run at 500kHz to avoid the AM band. The demo board has an EMI filter installed. The radiated EMI performance of the board is on Figures 3 to 5, showing the circuit passes CISPR25 Class 5 with a wide margin.

This USB converter was optimized for a maximum V_{CABLE} of 5V at 2.4A, enough for all USB applications. If higher, or lower load current is needed, please read the Cable Drop Compensation paragraph in the Applications section of the data sheet, and adjust all pertinent component values as needed. Always ensure the converter stays within the guaranteed switch current and the output voltage never exceeds 6.1V. If higher V_{CABLE} voltage is needed, please refer to Applications example on the data sheet. If V_{CABLE} is not connected to any load, V_{OUT} can be used to power

up a load. V_{SYS} can also be used to supply a 100mA load. When probing the board, pay attention to GND and C_GND.

On the demonstration board, they are connected together by default through R13 so a user can connect the ground clip of a probe to C_GND. However, if a user wants to evaluate an actual cable, the cable will replace R4 and R13. The copper between pads of R13 should be cut open. In this case, C_GND is no longer the same as GND. A differential measurement is needed to probe across the point of load.

The demonstration board also includes a USB socket. With the proper configuration of jumpers X1, X2, X3 and X4, the USB can be configured for different applications. See Table 1 for configurations. A 500mA onboard step load can also be activated to evaluate the load transient response of the circuit. To activate the step load, simply set jumper X5 to V^+ . The LT3697 data sheet gives a complete description of the part, operation and application information. The data sheet must be read in conjunction with this quick start guide for demo circuit 1893A.

Design files for this circuit board are available at <http://www.linear.com/demo/DC1893A>

LT, LT, LTC, LTM, Linear Technology and the Linear logo are registered trademarks of Linear Technology Corporation. All other trademarks are the property of their respective owners.

PERFORMANCE SUMMARY Specifications are at $T_A = 25^\circ\text{C}$

SYMBOL	PARAMETER	CONDITIONS	MIN	TYP	MAX	UNITS
V_{IN}	Input Supply Range		8		35	V
V_{CABLE}	Output Voltage		4.8	5	5.2	V
Max I_{OUT}	Maximum Output Current		2.4			A
Efficiency		$I_{\text{OUT}} = 2.4\text{A}$, Measured at V_{OUT}		90		%
Switching Frequency				500		kHz

Table 1. Configure X1–X4 for Different USB Applications

X1	X2	X3	X4	J3
DO NOT CARE	DO NOT CARE	DO NOT CARE	OPEN	NOT IN USE
OPEN	OPEN	SHORT	SET	USB–DCP
D ⁺	D ⁻	OPEN	SET	USB APPLE 2.4A

dc1893af

QUICK START PROCEDURE

Demonstration circuit 1893A is easy to set up to evaluate the performance of the LT3697. Refer to Figure 1 for proper equipment setup and follow the procedure below:

1. With power off, connect the input power supply to V_{IN} and GND.
2. With power off, connect the load to V_{CABLE} and C_GND.
3. Set X1–X5 to OPEN positions.
4. Turn on the power at the input.
5. Carefully evaluate other design parameters as needed.
6. If a USB device is to be connected to J3, use Table 1 as a guide to set X1–X4 for different USB applications. The total current provided at J3 and V_{CABLE} should not exceed 2.4A.
7. Set X5 to V^+ if a quick transient test is desired. The load step applied to V_{CABLE} is 500mA. Again, make sure the total load current does not exceed 2.4A during the test.

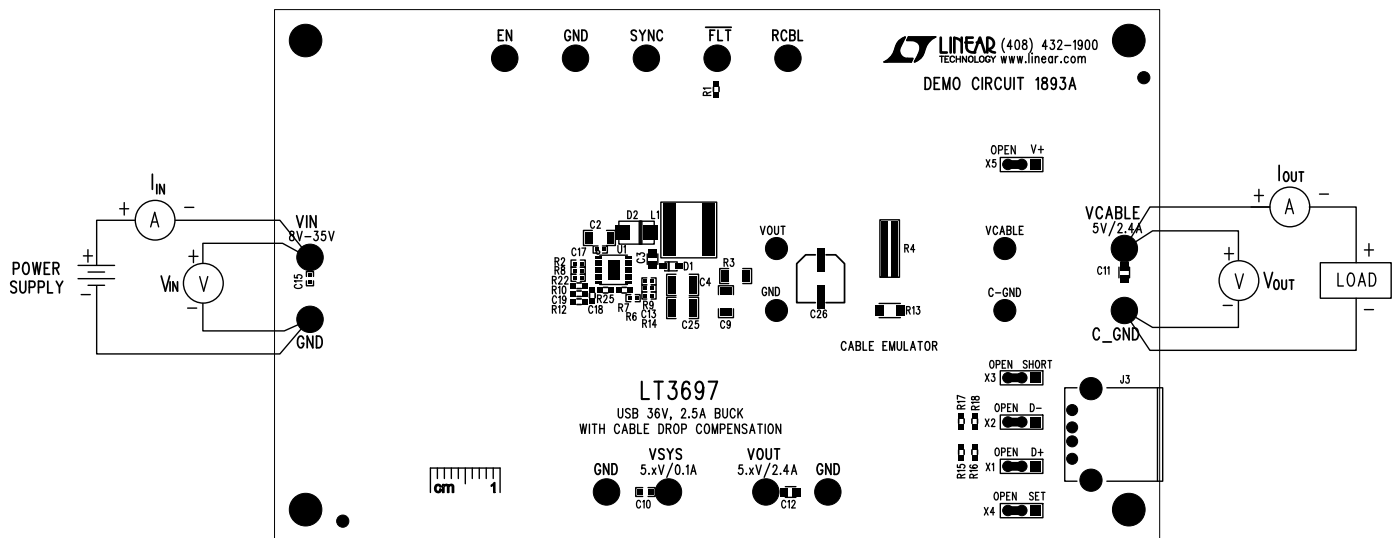

Figure 1. Proper Equipment Setup

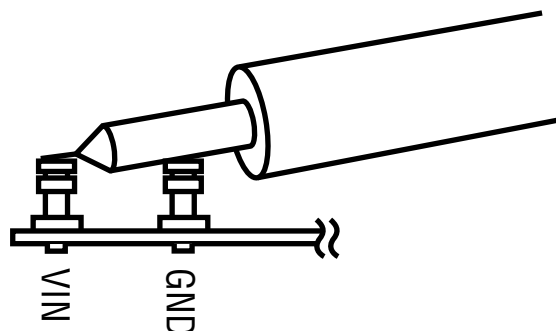

Figure 2. Measuring Output Ripple

QUICK START PROCEDURE

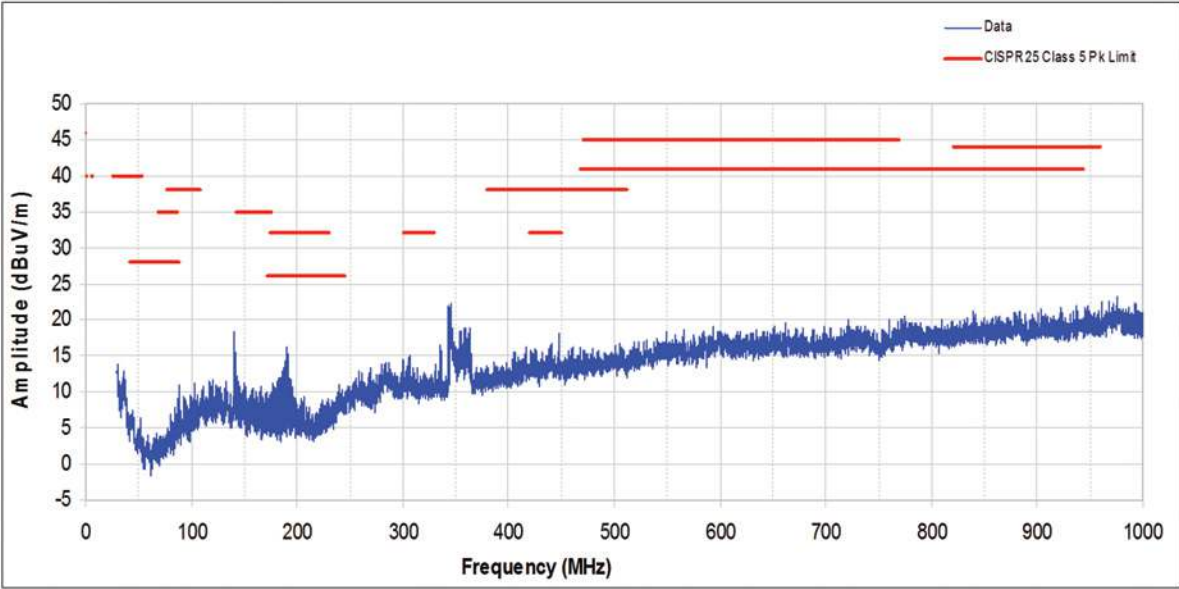

Figure 3. CISPR25, Class 5, Radiated Disturbances ALSE. Vertical Polarization

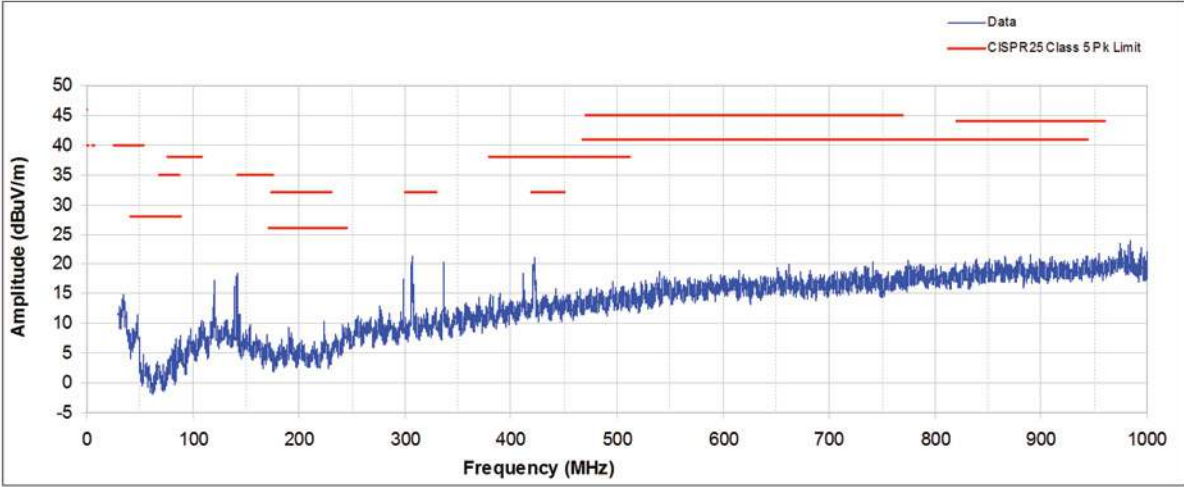

Figure 4. CISPR25, Class 5, Radiated Disturbances ALSE. Horizontal Polarization

QUICK START PROCEDURE

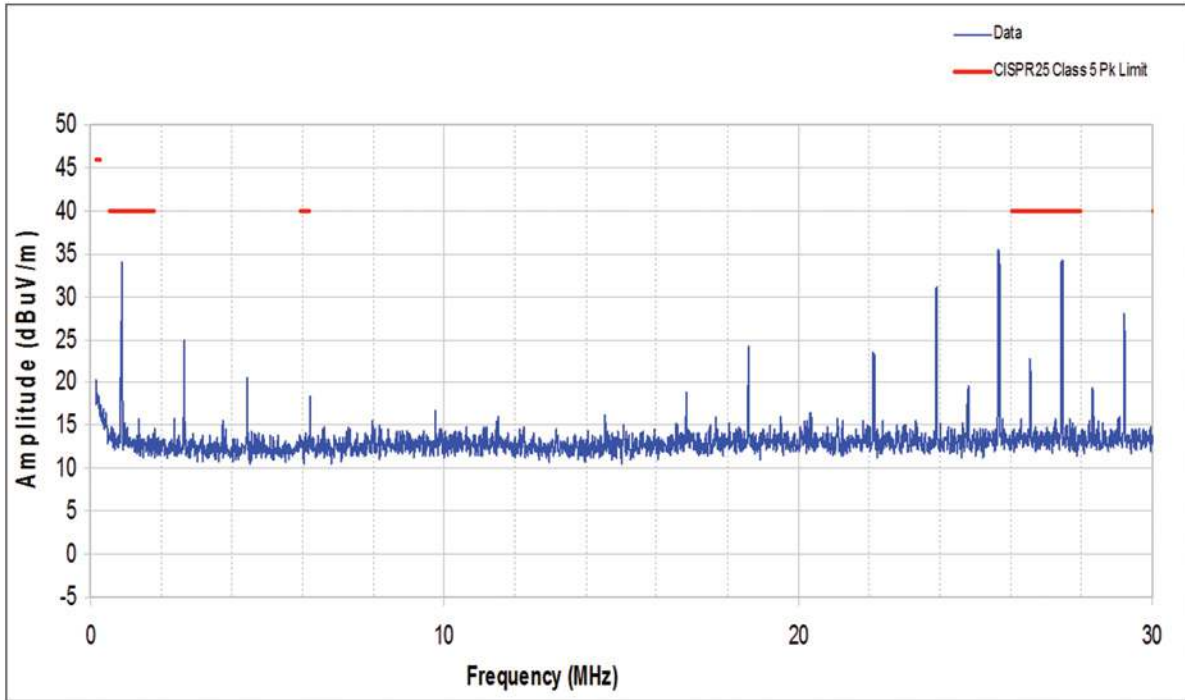

Figure 5. CISPR25, Class 5, Radiated Disturbances ALSE. Vertical Polarization

PARTS LIST

ITEM	QTY	REFERENCE	PART DESCRIPTION	MANUFACTURER/PART #
Required Circuit Components				
1	1	C1	CAP., ALUM, 22 μ F, 63V, 25%	SUN ELECT. 63CE22BS
2	3	C2, C7, C8	CAP., X7R, 4.7 μ F, 50V, 10% 1206	MURATA, GRM31CR71H475KA12L
3	1	C3	CAP., X7R, 1 μ F, 50V, 10% 0805	AVX, 08055C105KAT2A
4	1	C4	CAP., X7R, 47 μ F, 10V, 10% 1210	MURATA, GRM32ER71A476KE15L
5	1	C13	CAP., X7R, 10nF, 25V, 10% 0402	MURATA, GRM155R71E103KA01D
6	3	C15 to C17	CAP., X7R, 0.1 μ F, 50V, 10% 0402	TDK, C1005X7R1H104K
7	1	C18	CAP., COG, 330pF, 50V, 10% 0603	MURATA, GRM1885C1H331JA01D
8	1	C19	CAP., COG, 1nF, 50V, 5% 0603	AVX, 06035A102JAT2A
9	1	C26	CAP., ALUM, 120 μ F, 16V, 20%	SUN ELECT. 16HVP120M
10	1	D1	DIODE, CMDSH-3, SOD-323	CENTRAL SEMI., CMDSH-3TR
11	1	D2	RECTIFIER, 3A, 40V, SMA	ON SEMI., MBRA340T3G
12	1	FB1	FERRITE BEAD, BEAD 0805	TDK MPZ2012S221AT
13	5	X1-X5	HEADERS, SGL. ROW 3 PINS 2mm CTRS.	SULLINS NRPN031PAEN-RC
14	5	xX1-xX5	SHUNT, 2mm CTRS.	SAMTEC 2SN-BK-G
15	1	J3	USB, RIGHT ANGLE, RECEPTACLE	CNC TECH, LLC, 1002-001-01000
16	1	L1	IND., 10 μ H, NRS8040 TYPE	TAIYO YUDEN, NRS8040T100MJGJV
17	1	L2	IND., 22 μ H	TAIYO YUDEN, NRS8040T220MJGJV
18	1	Q1	POWER MOSFET, SOT23	DIODES INC, ZXMN3A14FTA
19	1	R1	RES., CHIP, 100k, 1/10 Ω , 5% 0603	VISHAY CRCW0603100K0JNEA
20	3	R2, R6, R22	RES., CHIP, 100k, 0.06 Ω , 5% 0402	VISHAY CRCW0402100KJNED
21	1	R3	RES., 0.022, 0.25 Ω , 1% 1206	VISHAY WSL1206R0220FEA
22	1	R4	RES., SENSE, 0.3, 2 Ω , 1% 0830	SSM THIN FILM TECH. RL7520WT-R30-F
23	2	R5, R23	RES., POWER, 18, 1 Ω , 1% 2512	SSM THIN FILM TECH. CPA2512Q18R0FS-T10
24	1	R7	RES., CHIP, 14.7k, 0.1 Ω , 1% 0603	VISHAY CRCW060314K7FKEA
25	1	R9	RES., CHIP, 10k, 0.06 Ω , 5% 0402	VISHAY CRCW040210K0JNED
26	1	R10	RES., CHIP, 174k, 0.1 Ω , 1% 0603	VISHAY CRCW0603174KFKEA
27	1	R12	RES., CHIP, 7.5k, 0.1 Ω , 5% 0603	VISHAY CRCW06037K50JNEA
28	2	R15, R16	RES., CHIP, 43.2k, 0.1 Ω , 1% 0603	VISHAY CRCW060343K2FKEA
29	2	R17, R18	RES., CHIP, 49.9k, 0.1 Ω , 1% 0603	VISHAY CRCW060349K9FKEA
30	1	R19	RES., CHIP, 10k, 0.1 Ω , 5% 0603	VISHAY CRCW060310K0JNEA
31	1	R20	RES., CHIP, 2M, 0.1 Ω , 1% 0603	VISHAY CRCW06032M00FKEA
32	2	R21, R24	RES., CHIP, 2, 0.25 Ω , 5% 1206	VISHAY CRCW12062R00JNEA
33	1	U1	IC., LT3697EMSE, MSE-16	LINEAR TECH., LT3697EMSE#PBF
34	1	U2	I.C., OSCILLATOR, TSOT-23-S5	LINEAR TECH., LTC6900CS5#PBF
35	1		DEMO CIRCUIT 1893A, REV 3	

DEMO MANUAL DC1893A

PARTS LIST

ITEM	QTY	REFERENCE	PART DESCRIPTION	MANUFACTURER/PART #
Additional Demo Board Circuit Components				
1	0	C9 (OPT)	CAP., 1206	
2	1	C10	CAP., X7R, 0.1 μ F, 25V, 10% 0603	TDK, C1608X7R1E104K
3	2	C11, C12	CAP., X7R, 1 μ F, 25V, 10% 0805	TDK, C2012X7R1E105K
4	1	C14	CAP., X7R, 2.2nF, 10V, 10% 0603	AVX, 0603ZC222KAT2A
5	0	C25 (OPT)	CAP., 1210	
6	0	R13	RES., CHIP, 1206	
7	0	R8, R14 (OPT)	RES., 0402	
8	0	R25 (OPT)	RES., 0603	
Hardware: For Demo Board Only				
1	13	E1-E13	TURRET, TESTPOINT	MILL-MAX, 2501-2-00-80-00-00-07-0
2	4	E14-E17	TESTPOINT, TURRET, 0.061" PBF	MILL-MAX, 2308-2-00-80-00-00-07-0
3	4	MH1-MH4	STAND-OFF, NYLON, 0.375"	KEystone, 8832 (SNAP ON)

SCHEMATIC DIAGRAM

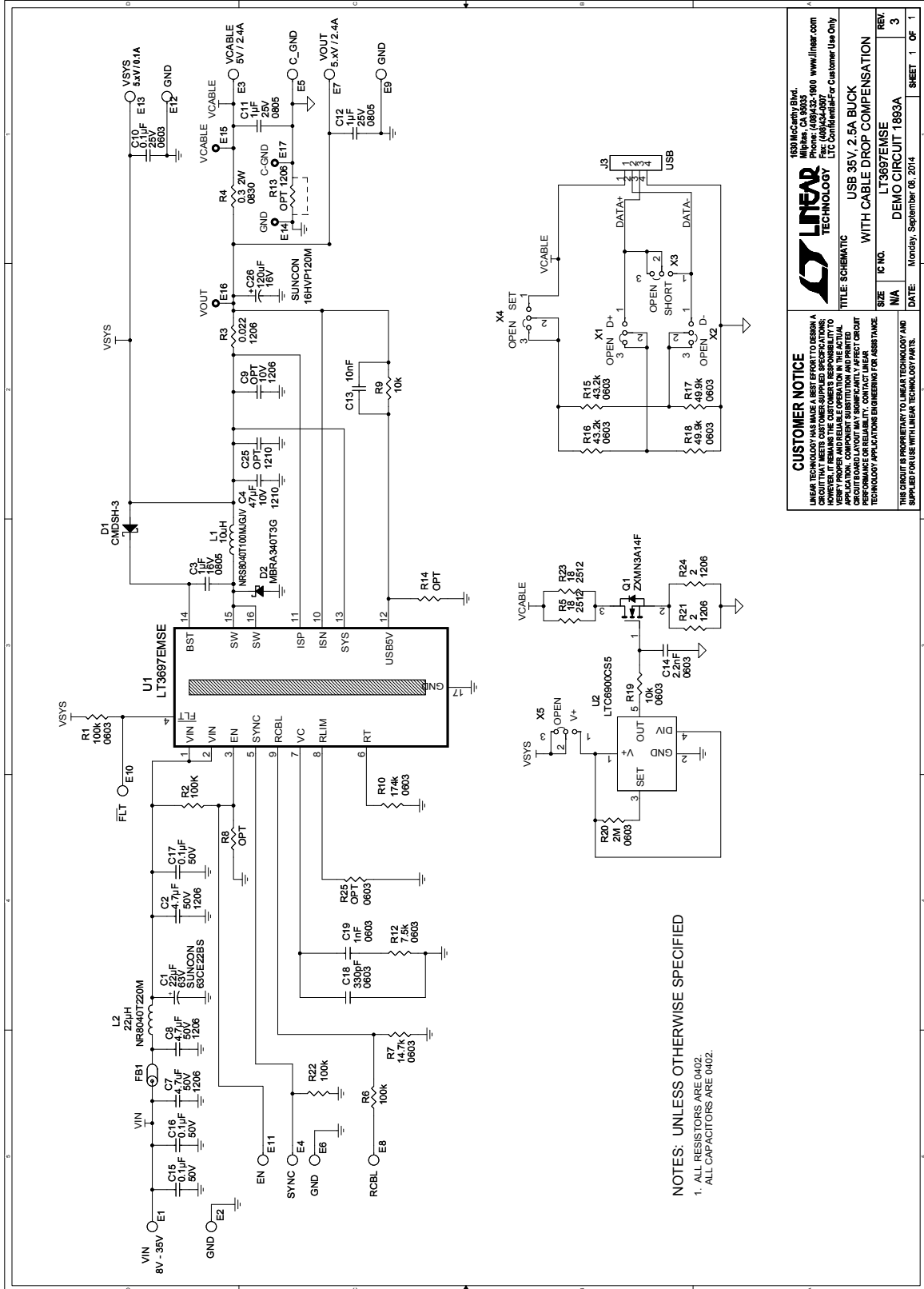

CUSTOMER NOTICE
 LINEAR TECHNOLOGY MAKES NO WARRANTY OR REPRESENTATION, EXPRESS OR IMPLIED, REGARDING THE SUITABILITY OF THIS CIRCUIT FOR ANY APPLICATION. HOWEVER, IT REMAINS THE CUSTOMER'S RESPONSIBILITY TO SELECT AND VERIFY THE APPROPRIATE COMPONENTS FOR THE INTENDED APPLICATION. COMPONENT SUBSTITUTION AND PRINTED CIRCUIT BOARD LAYOUT MAY SIGNIFICANTLY AFFECT CIRCUIT PERFORMANCE. CUSTOMERS ARE ADVISED TO CONTACT LINEAR TECHNOLOGY APPLICATION ENGINEERING FOR ASSISTANCE.

LINEAR TECHNOLOGY
 1650 McCarty Blvd.
 Milpitas, CA 95035
 Phone: (408) 255-0000 www.linear.com
 Fax: (408) 255-3007
 LTC Confidential - For Customer Use Only

TITLE: SCHEMATIC
WITH CABLE DROP COMPENSATION
USB 3.5V, 2.5A BUCK
LT3697EMSE
DEMO CIRCUIT 1893A

SIZE	IC NO.	REV
N/A	LT3697EMSE	3
DATE	Monday, September 08, 2014	SHEET 1 OF 1

DEMO MANUAL DC1893A

DEMONSTRATION BOARD IMPORTANT NOTICE

Linear Technology Corporation (LTC) provides the enclosed product(s) under the following **AS IS** conditions:

This demonstration board (DEMO BOARD) kit being sold or provided by Linear Technology is intended for use for **ENGINEERING DEVELOPMENT OR EVALUATION PURPOSES ONLY** and is not provided by LTC for commercial use. As such, the DEMO BOARD herein may not be complete in terms of required design-, marketing-, and/or manufacturing-related protective considerations, including but not limited to product safety measures typically found in finished commercial goods. As a prototype, this product does not fall within the scope of the European Union directive on electromagnetic compatibility and therefore may or may not meet the technical requirements of the directive, or other regulations.

If this evaluation kit does not meet the specifications recited in the DEMO BOARD manual the kit may be returned within 30 days from the date of delivery for a full refund. **THE FOREGOING WARRANTY IS THE EXCLUSIVE WARRANTY MADE BY THE SELLER TO BUYER AND IS IN LIEU OF ALL OTHER WARRANTIES, EXPRESSED, IMPLIED, OR STATUTORY, INCLUDING ANY WARRANTY OF MERCHANTABILITY OR FITNESS FOR ANY PARTICULAR PURPOSE. EXCEPT TO THE EXTENT OF THIS INDEMNITY, NEITHER PARTY SHALL BE LIABLE TO THE OTHER FOR ANY INDIRECT, SPECIAL, INCIDENTAL, OR CONSEQUENTIAL DAMAGES.**

The user assumes all responsibility and liability for proper and safe handling of the goods. Further, the user releases LTC from all claims arising from the handling or use of the goods. Due to the open construction of the product, it is the user's responsibility to take any and all appropriate precautions with regard to electrostatic discharge. Also be aware that the products herein may not be regulatory compliant or agency certified (FCC, UL, CE, etc.).

No License is granted under any patent right or other intellectual property whatsoever. **LTC assumes no liability for applications assistance, customer product design, software performance, or infringement of patents or any other intellectual property rights of any kind.**

LTC currently services a variety of customers for products around the world, and therefore this transaction **is not exclusive**.

Please read the DEMO BOARD manual prior to handling the product. Persons handling this product must have electronics training and observe good laboratory practice standards. **Common sense is encouraged.**

This notice contains important safety information about temperatures and voltages. For further safety concerns, please contact a LTC application engineer.

Mailing Address:

Linear Technology
1630 McCarthy Blvd.
Milpitas, CA 95035

Copyright © 2004, Linear Technology Corporation