

AC coupled HDMI level shifter

Features

- Converts low-swing alternating current (AC) coupled differential input to high-definition multimedia interface (HDMI) rev 1.3 compliant
- HDMI level shifting operation up to 2.7 Gbps per lane
- Integrated 50 Ω termination resistors for AC-coupled differential inputs
- Input/output transition minimized differential signaling (TMDS) enable/disable
- Output slew rate control on TMDS outputs to minimize electromagnetic interference (EMI)
- Fail-safe outputs for backdrive protection
- No re-timing or configuration required
- Inter-pair output skew < 250 ps
- Intra-pair output skew < 10 ps
- Single power supply of 3.3 V
- ESD protection: ± 6 KV HBM on all I/O pins
- Integrated display data channel (DDC) level shifters. Pass-gate voltage limiters allow 3.3 V termination on graphics and memory controller hub (GMCH) pins and 5 V DDC termination on HDMI connector pins
- Hot-plug detect (HPD) signal level shifter from HDMI/DVI connector
- Integrated pull-down resistor on HPD_SINK and OE_N inputs

Applications

- Notebooks
- PC motherboards and graphic cards
- Dongles/cable adapters

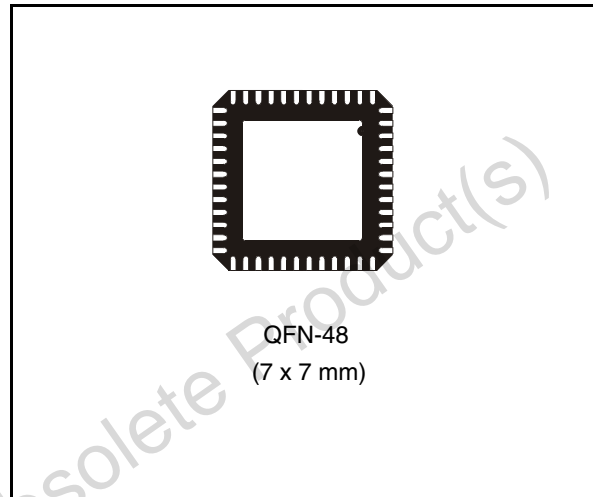

Description

The STHDLS101 is a high-speed high-definition multimedia interface (HDMI) level shifter that converts low-swing AC coupled differential input to HDMI 1.3 compliant open-drain current steering RX-terminated differential output. Through the existing PCI-E pins in the graphics and memory controller hub (GMCH) of PCs or notebook motherboards, the pixel clock provides the required bandwidth (1.65 Gbps, 2.25 Gbps) for the video supporting 720p, 1080i, 1080p with a total of 36-bit resolution. The HDMI is multiplexed onto the PCIe pins in the motherboard where the AC coupled HDMI at 1.2 V is output by GMCH. The AC coupled HDMI is then level shifter by this device to 3.3 V DC coupled HDMI output. The STHDLS101 supports up to 2.7 Gbps, which is enough for 12 bits of color depth per channel, as indicated in HDMI rev 1.3. The device operates from a single 3.3 V supply and is available in a 48-pin QFN package.

Table 1. Device summary

Order code	Package	Packing
STHDLS101QTR	QFN-48	Tape and reel

Contents

1	Block diagram	3
2	System interface	4
3	Pin configuration	6
3.1	Pin description	7
4	Functional description	11
5	Maximum ratings	13
5.1	Recommended operating conditions	14
5.1.1	Power supply and temperature range	14
5.1.2	Differential inputs (IN_D signals)	14
5.2	TMDS outputs (OUT_D signals)	15
5.3	HPD input and output characteristics	16
5.4	DDC input and output characteristics	17
5.5	OE_ input characteristics	18
5.6	HPD input resistor	18
5.7	ESD performance	18
6	Application information	19
6.1	Power supply sequencing	19
6.2	Supply bypassing	19
6.3	Differential traces	19
7	Package mechanical data	20
8	Revision history	24

1 Block diagram

Figure 1. STHDL5101 block diagram

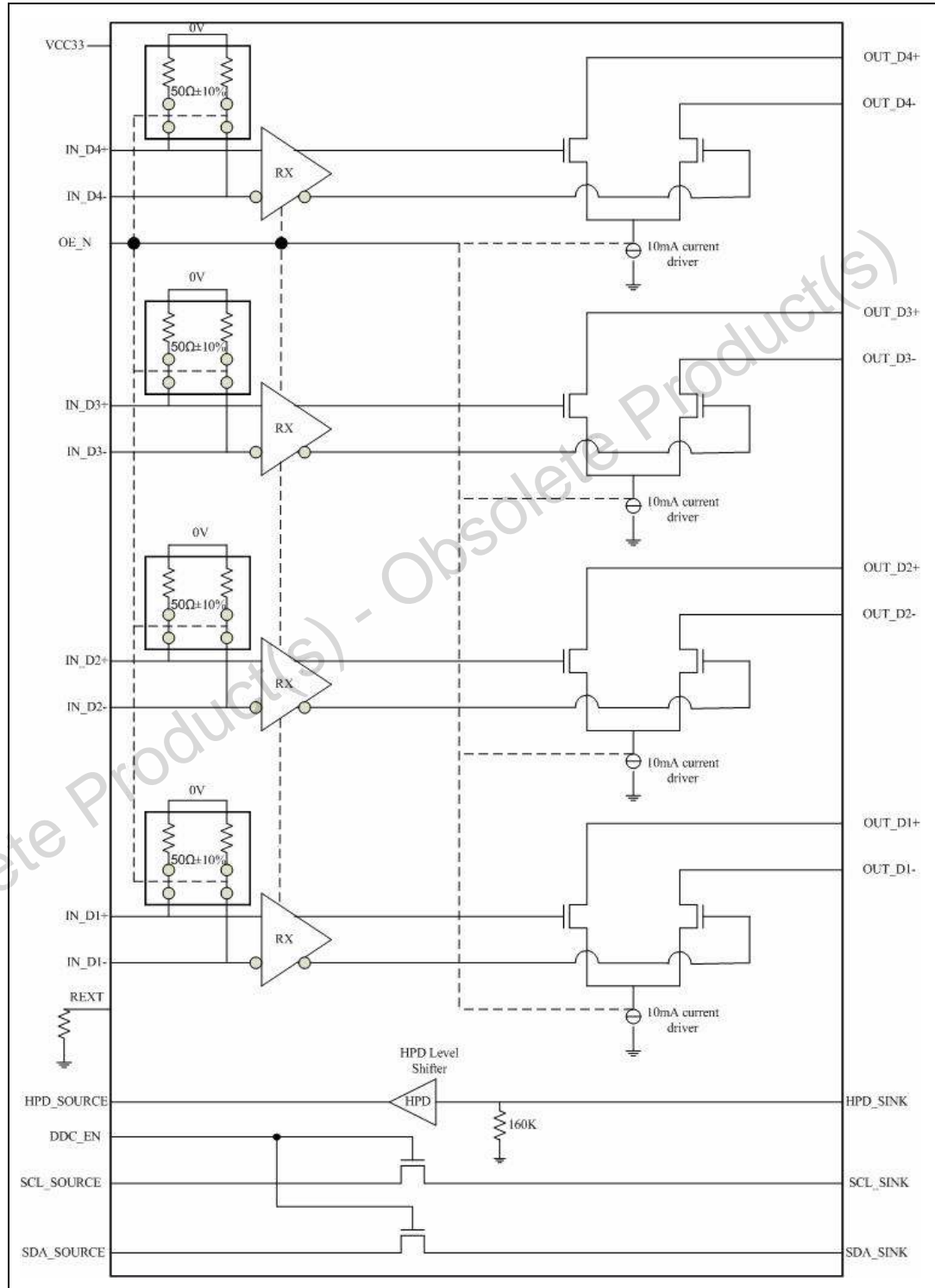

2 System interface

Figure 2. System interface

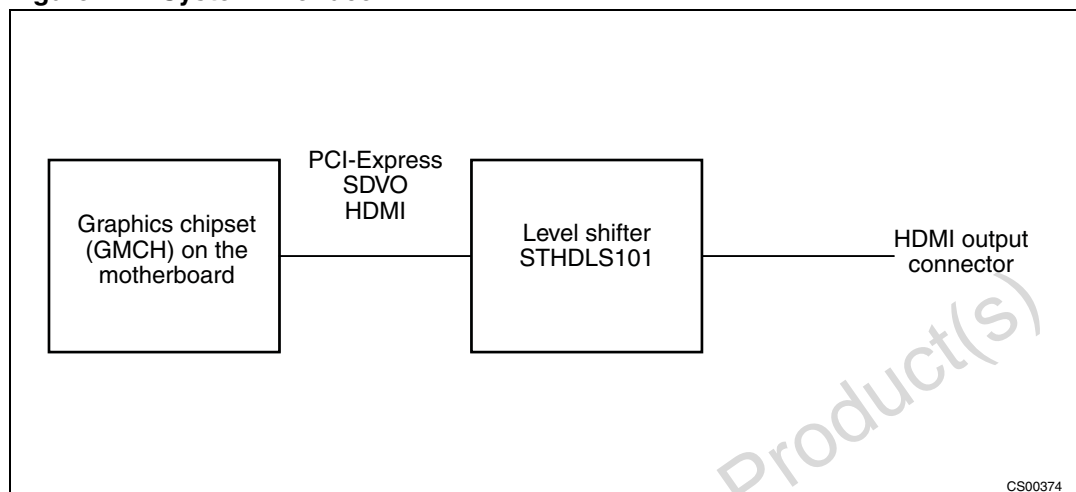

Figure 3. Cable adapter

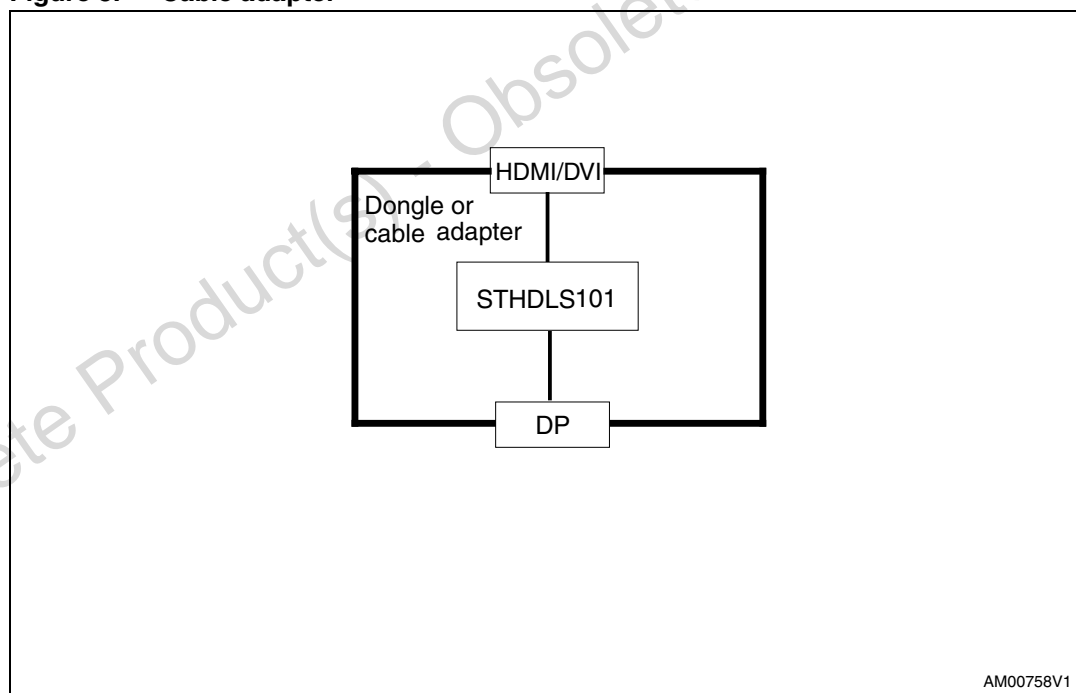
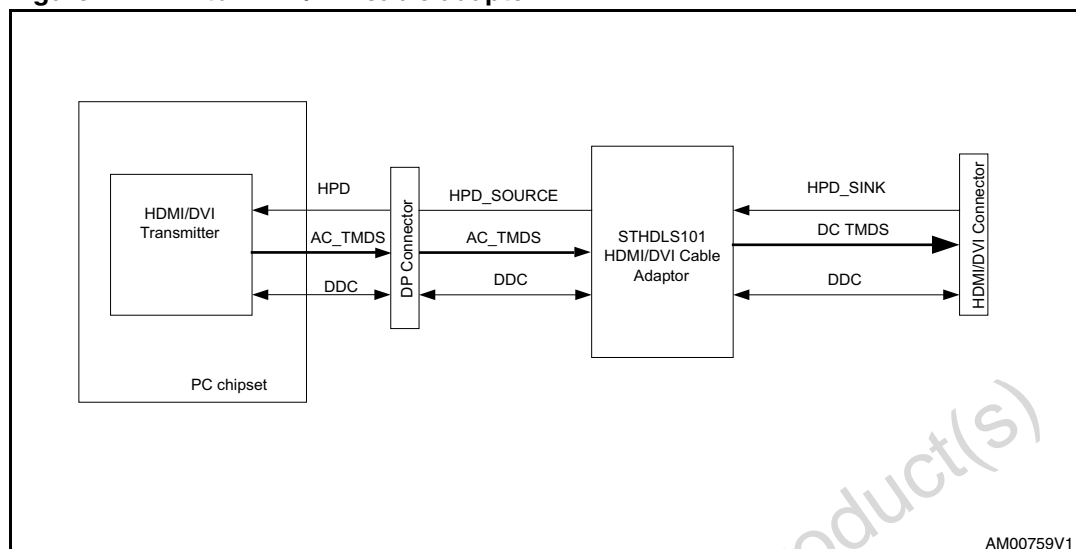

Figure 4. DP to HDMI/DVI cable adapter



Obsolete Product(s) - Obsolete Product(s)

3 Pin configuration

Figure 5. STHDLS101 pin configuration

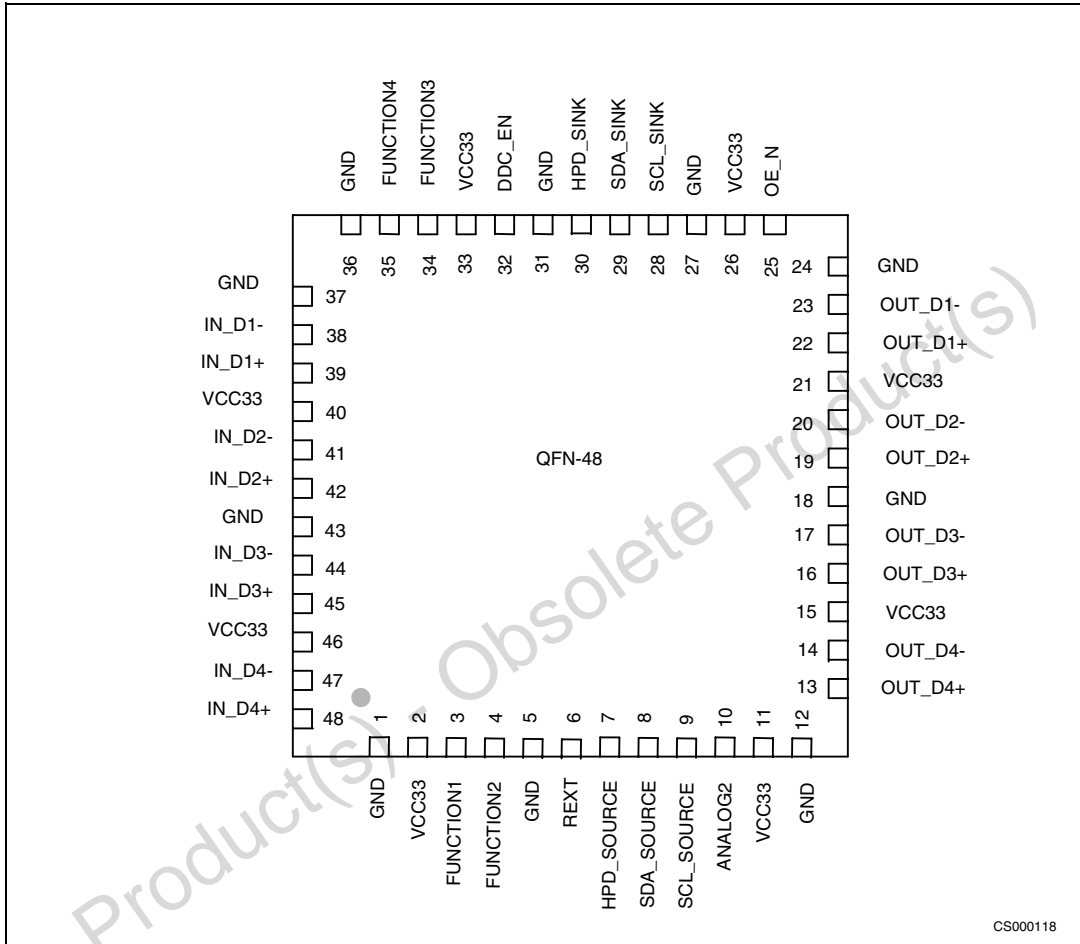

CS000118

3.1 Pin description

Table 2. Pin description

Pin number	Name	Type	Function
1	GND	Power	Ground
2	VCC33	Power	3.3 V \pm 10% DC supply
3	FUNCTION1	Vendor-specific control or test pins	Function pins are to enable vendor-specific features or test modes. For normal operation, these pins are tied to GND or VCC33. For consistent interoperability, GND is the preferred default connection for these signals.
4	FUNCTION2	Vendor-specific control or test pins	Function pins are to enable vendor-specific features or test modes. For normal operation, these pins are tied to GND or VCC33. For consistent interoperability, GND is the preferred default connection for these signals.
5	GND	Power	Ground
6	REXT	Analog	Connection to external resistor. Resistor value specified by device manufacturer. Acceptable connections to this pin are: - Resistor to GND - Resistor to 3.3 V - NC (direct connections to V _{CC} or GND are through a 0 Ω resistor for layout compatibility)
7	HPD_SOURCE	Output	0 to 3.3 V (nominal) output signal. This is level-shifted version of the HPD_SINK signal.
8	SDA_SOURCE	I/O	3.3 V DDC data I/O. Pulled-up by external termination to 3.3 V. Connected to SDA_SINK through voltage-limiting integrated NMOS pass-gate.
9	SCL_SOURCE	Input	3.3 V DDC clock I/O. Pulled-up by external termination to 3.3 V. Connected to SCL_SINK through voltage-limiting integrated NMOS pass-gate.
10	ANALOG2	Analog	Analog connection determined by vendor. Acceptable connections to this pin are: - Resistor or capacitor to GND - Resistor or capacitor to 3.3 V - Short to 3.3 V or to GND - NC
11	VCC33	Power	3.3 V \pm 10% DC supply
12	GND	Power	Ground
13	OUT_D4+	Output	HDMI 1.3 compliant TMDS output. OUT_D4+ makes a differential output signal with OUT_D4-.

Table 2. Pin description (continued)

Pin number	Name	Type	Function		
14	OUT_D4-	Output	HDMI 1.3 compliant TMDS output. OUT_D4- makes a differential output signal with OUT_D4+.		
15	VCC33	Power	3.3 V±10% DC supply		
16	OUT_D3+	Output	HDMI 1.3 compliant TMDS output. OUT_D3+ makes a differential output signal with OUT_D3-.		
17	OUT_D3-	Output	HDMI 1.3 compliant TMDS output. OUT_D3- makes a differential output signal with OUT_D3+.		
18	GND	Power	Ground		
19	OUT_D2+	Output	HDMI 1.3 compliant TMDS output. OUT_D2+ makes a differential output signal with OUT_D2-.		
20	OUT_D2-	Output	HDMI 1.3 compliant TMDS output. OUT_D2- makes a differential output signal with OUT_D2+.		
21	VCC33	Power	3.3 V±10% DC supply		
22	OUT_D1+	Output	HDMI 1.3 compliant TMDS output. OUT_D1+ makes a differential output signal with OUT_D1-.		
23	OUT_D1-	Output	HDMI 1.3 compliant TMDS output. OUT_D1- makes a differential output signal with OUT_D1+.		
24	GND	Power	Ground		
25	OE_N	Input	Enable for level shifter path. 3.3 V tolerant low-voltage single-ended input. Internal pull-down enables the device when unconnected.		
			OE_N	IN_D termination	OUT_D Outputs
			1	High-Z	High-Z
			0	50Ω	Active
26	VCC33	Power	3.3 V±10% DC supply		
27	GND	Power	Ground		
28	SCL_SINK	Output	5 V DDC clock I/O. Pulled-up by external termination to 5 V. Connected to SCL_SOURCE through voltage-limiting integrated NMOS pass-gate.		
29	SDA_SINK	I/O	5V DDC data I/O. Pulled-up by external termination to 5V. Connected to SDA_SOURCE through voltage-limiting integrated NMOS pass-gate.		

Table 2. Pin description (continued)

Pin number	Name	Type	Function	
30	HPD_SINK	Input	Low-frequency, 0 to 5 V (nominal) input signal. This signal comes from the HDMI connector. Voltage high indicates “plugged” state; voltage low indicates “unplugged” state. HPD_SINK is pulled down by an integrated 160 KΩ pull-down resistor.	
31	GND	Power	Ground	
32	DDC_EN	Input	Enables bias voltage to the DDC pass-gate level shifter gates. (May be implemented as a bias voltage connection to the DDC pass-gate themselves).	
			DDC_EN	Pass-gate
			0 V	Disabled
			3.3 V	Enabled
33	VCC33	Power	3.3 V ± 10% DC supply	
34	FUNCTION3	Vendor-specific control or test pins	Function pins are to enable vendor-specific features or test modes. For normal operation, these pins are tied to GND or VCC33. For consistent interoperability, GND is the preferred default connection for these signals.	
35	FUNCTION4	Vendor-specific control or test pins	Function pins are to enable vendor-specific features or test modes. For normal operation, these pins are tied to GND or VCC33. For consistent interoperability, GND is the preferred default connection for these signals.	
36	GND	Power	Ground	
37	GND	Power	Ground	
38	IN_D1-	Input	Low-swing differential input from GMCH PCIE outputs. IN_D1- makes a differential pair with IN_D1+.	
39	IN_D1+	Input	Low-swing differential input from GMCH PCIE outputs. IN_D1+ makes a differential pair with IN_D1-.	
40	VCC33	Power	3.3 V±10% DC supply	
41	IN_D2-	Input	Low-swing differential input from GMCH PCIE outputs. IN_D2- makes a differential pair with IN_D2+.	
42	IN_D2+	Input	Low-swing differential input from GMCH PCIE outputs. IN_D2+ makes a differential pair with IN_D2-.	
43	GND	Power	Ground	
44	IN_D3-	Input	Low-swing differential input from GMCH PCIE outputs. IN_D3- makes a differential pair with IN_D3+.	
45	IN_D3+	Input	Low-swing differential input from GMCH PCIE outputs. IN_D3+ makes a differential pair with IN_D3-.	

Table 2. Pin description (continued)

Pin number	Name	Type	Function
46	VCC33	Power	3.3 V±10% DC supply
47	IN_D4-	Input	Low-swing differential input from GMCH PCIE outputs. IN_D4- makes a differential pair with IN_D4+.
48	IN_D4+	Input	Low-swing differential input from GMCH PCIE outputs. IN_D4+ makes a differential pair with IN_D4-.

Obsolete Product(s) - Obsolete Product(s)

4 Functional description

This section describes the basic functionality of the STHDLS101 device.

Power supply

The STHDLS101 is powered by a single DC power supply of 3.3 V ± 10%.

Clocking

This device does not retime any data. The device contains no state machines. No inputs or outputs of the device are latched or clocked.

Reset

This device acts as a level shifter, reset is not required.

OE_N function

When OE_N is asserted (low level), the IN_D and OUT_D signals are fully functional. Input termination resistors are enabled and any internal bias circuits are turned on.

The OE_N pin has an internal pull-down that enables the chip if left unconnected.

When OE_N is de-asserted (high level), the OUT_D outputs are in high impedance state.

The IN_D input buffers are disabled and the IN_D termination resistors are disabled.

Internal bias circuits for the differential inputs and outputs are turned off. Power consumption of the chip is minimized.

The HPD_SINK input and HPD_SOURCE output are not affected by OE_N. The SCL and SDA pass-gates are not affected by OE_N.

Table 3. OE_N description

OE_N	Device state	Comments
Asserted (low level) or unconnected	Differential input buffers and output buffers enabled. Input impedance = 50 Ω	Normal functioning state for IN_D to OUT_D level shifting function.
De-asserted (high level)	Low-power state. Differential input buffers and terminations are disabled. Differential input buffers are in high-impedance state. OUT_D level shifting outputs are disabled. OUT_D level shifting outputs are in a high-impedance state. Internal bias currents are turned off.	Intended for lowest power condition when: <ul style="list-style-type: none"> • No display is plugged in or • The level shifted data path is disabled HPD_SINK input and HPD_SOURCE output are not affected by OE_N. SCL_SOURCE, SCL_SINK, SDA_SOURCE and SDA_SINK signals and functions are not affected by OE_N.

Table 4. OE_N function

OE_N	IN_Dx	OUT_Dx (TMDS outputs)	Notes
De-asserted (high level)	High-Z	High-Z	Device disabled. Low power state. Internal bias currents are disabled.
Asserted (low level) or unconnected	50 Ω termination	Enabled	Level shifting mode enabled.

Obsolete Product(s) - Obsolete Product(s)

5 Maximum ratings

Stressing the device above the rating listed in the “Absolute maximum ratings” table may cause permanent damage to the device. These are stress ratings only and operation of the device at these or any other conditions above those indicated in the Operating sections of this specification is not implied. Exposure to Absolute maximum rating conditions for extended periods may affect device reliability.

Table 5. Absolute maximum ratings

Symbol	Parameter		Value	Unit
V _{CC}	Supply voltage to ground potential		-0.5 to +4.0	V
V _I	DC input voltage (TMDS and PCIe ports)		-0.5 to +4.0	V
	Control pins		-0.5 to +4.0	V
	SDA_SINK, SCL_SINK, HPD_SINK pins		-0.5 to +6	V
I _O	DC output current		120	mA
P _D	Power dissipation		1	W
T _{STG}	Storage temperature		-65 to +150	°C
T _L	Lead temperature (10 sec)		300	°C
V _{ESD}	Electrostatic discharge voltage on IOs ⁽¹⁾	Human body model	±6	kV

1. In accordance with the MIL standard 883 method 3015

Table 6. Thermal data

Symbol	Parameter	QFN-48	Unit
θ _{JA}	Junction-ambient thermal coefficient	48	°C/W

5.1 Recommended operating conditions

5.1.1 Power supply and temperature range

Table 7. Power supply and temperature range

Symbol	Parameter	Comments	Min	Typ	Max	Unit
V_{CC33}	3.3 V power supply		3.0	3.3	3.6	V
I_{CC}	Maximum power supply current	Total current from V_{CC} 3.3 V power supply			100	mA
T	Operating temperature range		-40		85	°C

5.1.2 Differential inputs (IN_D signals)

Table 8. Differential input characteristics for IN_D signals

Symbol	Parameter	Comments	Min	Typ	Max	Unit
Tbit	Unit interval	Tbit is determined by the display mode. Nominal bit rate ranges from 250 Mbps to 2.5 Gbps per lane. Nominal Tbit at 2.5 Gbps = 400 ps. 360 ps = 400 ps – 10%	360			ps
$V_{RX-DIFFp-p}$	Differential input peak to peak voltage	$V_{RX-DIFFp-p}=2*V_{RX-D+} - V_{RX-D-}$. Applies to IN_D signals.	0.175		1.2	V
T_{RX-EYE}	Minimum eye width at IN_D input pair	The level shifter may add a maximum of 0.02UI jitter	0.8			Tbit
$V_{CM-AC-pp}$	AC peak common mode input voltage	$V_{CM-AC-pp}= V_{RX-D+} + V_{RX-D-} /2 - V_{RX-CM-DC}$. $V_{RX-CM-DC}=DC(avg)$ of $ V_{RX-D+} + V_{RX-D-} /2$. $V_{CM-AC-pp}$ includes all frequencies above 30 kHz.			100	mV
Z_{RX-DC}	DC single-ended input impedance	Applies to IN_D+ as well as IN_D- pins (50 Ω \pm 20% tolerance)	40	50	60	Ω
$V_{RX-Bias}$	RX input termination voltage	Intended to limit power-up stress on chipset's PCIE output buffers	0		2	V
$Z_{RX-HIGH-Z}$	Single-ended input resistance for IN_Dx when inputs are in high-Z state	Differential inputs must be in a high impedance state	100			K Ω

5.2 TMDS outputs (OUT_D signals)

The level shifter's TMDS outputs are required to meet the HDMI 1.3 specifications. The HDMI 1.3 specification is assumed to be the correct reference in instances where this document conflicts with the HDMI 1.3 specification.

Table 9. Differential output characteristics for TMDS OUT_D signals

Symbol	Parameter	Comments	Min	Typ	Max	Unit
V _H	Single-ended high level output voltage	AVCC is the DC termination voltage in the HDMI or DVI sink. AVCC is nominally 3.3 V	AVCC-10 mV	AVCC	AVCC+10 mV	V
V _L	Single-ended low level output voltage	The open-drain output pulls down form AVCC	AVCC-600 mV	AVCC-500 mV	AVCC-400 mV	V
V _{SWING}	Single-ended output swing voltage	Swing down from TMDS termination voltage (3.3 V±10%)	400 mV	500 mV	600 mV	V
I _{OFF}	Single-ended current in high-Z state	Measured with TMDS outputs pulled up to AVCC max (3.6 V) through 50 Ω resistors			10	μA
T _R	Rise time	Maximum rise/fall time @ 2.7 Gbps = 148 ps. 125 ps = 148 – 15%	125 ps		0.4 Tbit	ps
T _F	Fall time	Maximum rise/fall time @ 2.7 Gbps = 148 ps. 125 ps = 148 – 15%	125 ps		0.4 Tbit	ps
T _{SKEW-INTRA}	Intra-pair differential skew	This differential skew budget is in addition to the skew presented between D+ and D- paired input pins.			10	ps
T _{SKEW-INTER}	Inter-pair lane to lane output skew	This lane-to-lane skew budget is in addition to the skew between differential input pairs.			250	ps
T _{JIT}	Jitter added to TMDS signals	Jitter budget for TMDS signals as they pass through the level shifter. 7.4 ps = 0.02 Tbit at 2.7 Gbps			7.4	ps

5.3 HPD input and output characteristics

Table 10. HPD_SINK input and HPS_SOURCE output

Symbol	Parameter	Comment	Min	Typ	Max	Unit
V_{IH-HPD_SINK}	HPD_SINK input high level	Low speed input changes state on cable plug/unplug	2	5.0	5.3	V
V_{IL-HPD_SINK}	HPD_SINK input low level		0		0.8	V
I_{IN-HPD_SINK}	HPD_SINK input leakage current	Measured with HPD_SINK at V_{IH-HPD} max and V_{IL-HPD} min			50	μ A
V_{OH-HPD_SOURCE}	HPD_SOURCE output high level	$V_{CC} = 3.3 V \pm 10\%$	2.5		V_{CC}	V
V_{OL-HPD_SOURCE}	HPD_SOURCE output low level		0		0.02	V
T_{HPD}	HPD_SINK to HPD_SOURCE propagation delay	Time from HPD_SINK changing state to HPD_SOURCE changing state. Includes HPD_SOURCE rise/fall time $C_L = 10$ pF			200	ns
T_{RF-HPD}	HPD_SOURCE rise/fall time	Time required to transition from V_{OH-HPD_SOURCE} to V_{OL-HPD_SOURCE} or from V_{OL-HPD_SOURCE} to V_{OH-HPD_SOURCE} $C_L = 10$ pF	1		20	ns

5.4 DDC input and output characteristics

Table 11. SDA_SOURCE, SCL_SOURCE and SDA_SINK, SCL_SINK characteristics

Symbol	Parameter	Comment	Min	Typ	Max	Unit
V_I	Input voltage on SDA_SINK, SCL_SINK pins	Voltage on the DDC pins on connector end	0		5.5	V
I_{LKG}	Input leakage current on SDA_SINK, SCL_SINK pins	$V_{CC} = 3.3\text{ V}$ $V_I = 0.1 V_{DD}$ to $0.9 V_{DD}$ to isolated DDC inputs V_{DD} = external pull-up resistor voltage on SDA_SINK and SCL_SINK inputs (maximum of 5.5 V)	-10		10	μA
I_{OFF}	Power-down leakage current on SDA_SINK, SCL_SINK pins	$V_{CC} = 0.0\text{ V}$ $V_I = 0.1 V_{DD}$ to $0.9 V_{DD}$ to DDC sink inputs V_{DD} = external pull-up resistor voltage on SDA_SINK and SCL_SINK inputs (maximum of 5.5 V) SDA_SOURCE, SCL_SOURCE = 0.0 V	-10		10	μA
$C_{I/O}$	Input/output capacitance (switch off)	$V_{I(pp)} = 1\text{ V}$, 100 KHz $V_{CC} = 3.3\text{ V}$, $T = 25\text{ }^\circ\text{C}$		5		pF
$C_{I/O}$	Input/output capacitance (switch on)	$V_{I(pp)} = 1\text{ V}$, 100 KHz $V_{CC} = 3.3\text{ V}$, $T = 25\text{ }^\circ\text{C}$			10	pF
R_{ON}	Switch resistance	$I_O = 3\text{ mA}$, $V_O = 0.4\text{ V}$ $V_{CC} = 3.3\text{ V}$		27	40	Ω
T_{PD}	DDC_SINK to DDC_SOURCE propagation delay	Time from DDC_SINK changing state to DDC_SOURCE changing state while the pass gate is enabled. $C_L = 10\text{ pF}$ $R_{PU} = 1.5\text{ K (min)}$, 2.0 K (max)		8	15	ns
T_{SX}	Switch time from DDC_EN to the valid state on DDC_SOURCE	$C_L = 10\text{ pF}$ $R_{PU} = 1.5\text{ K (min)}$, 2.0 K (max)		8	15	ns

5.5 OE_ input characteristics

Table 12. OE_N input characteristics

Symbol	Parameter	Comment	Min	Typ	Max	Unit
V_{IH-OE_N}	Input high level		2		VCC33	V
V_{IL-OE_N}	Input low level		0		0.8	V
I_{IN-OE_N}	Input leakage current	Measured with OE_N at V_{IH-OE_N} max and V_{IL-OE_N} mix			200	μ A

5.6 HPD input resistor

Table 13. HDP input resistor

Symbol	Parameter	Comment	Min	Typ	Max	Unit
R_{HPD}	HPD_SINK input pull-down resistor	Guarantees HPD_SINK is LOW when no display is plugged in	130 K	160 K	190 K	Ω

5.7 ESD performance

Table 14. ESD performance

Symbol	Parameter	Test condition	Min	Typ	Max	Unit
ESD	MIL STD 883 method 3015 (all pins)	Human body model (HBM)	-6		+6	kV

6 Application information

6.1 Power supply sequencing

A proper power supply sequencing is advised for all CMOS devices. It is recommended to always apply V_{CC} before applying any signals to the input/output or control pins.

6.2 Supply bypassing

Bypass each of the V_{CC} pins with 0.1 μ F and 1nF capacitors in parallel as close to the device as possible, with the smaller valued capacitor as close to the V_{CC} pin of the device as possible.

6.3 Differential traces

The high-speed inputs and TMDS outputs are the most critical parts for the device. There are several considerations to minimize discontinuities on these transmission lines between the connectors and the device.

- a) Maintain 100 Ω differential transmission line impedance into and out of the device.
- b) Keep an uninterrupted ground plane below the high-speed I/Os.
- c) Keep the ground-path vias to the device as close as possible to allow the shortest return current path.
- d) Layout of the TMDS differential outputs should be with the shortest stubs from the connectors.

Output trace characteristics affect the performance of the STHDL101. Use controlled impedance traces to match trace impedance to both the transmission medium impedance and termination resistor. Run the differential traces close together to minimize the effects of the noise. Reduce skew by matching the electrical length of the traces. Avoid discontinuities in the differential trace layout. Avoid 90 ° C turns and minimize the number of vias to further prevent impedance discontinuities.

7 Package mechanical data

In order to meet environmental requirements, ST offers these devices in ECOPACK® packages. These packages have a Lead-free second level interconnect. The category of second Level Interconnect is marked on the package and on the inner box label, in compliance with JEDEC Standard JESD97. The maximum ratings related to soldering conditions are also marked on the inner box label. ECOPACK is an ST trademark. ECOPACK specifications are available at: www.st.com.

Obsolete Product(s) - Obsolete Product(s)

Figure 6. QFN-48 (7 x 7 mm) package outline

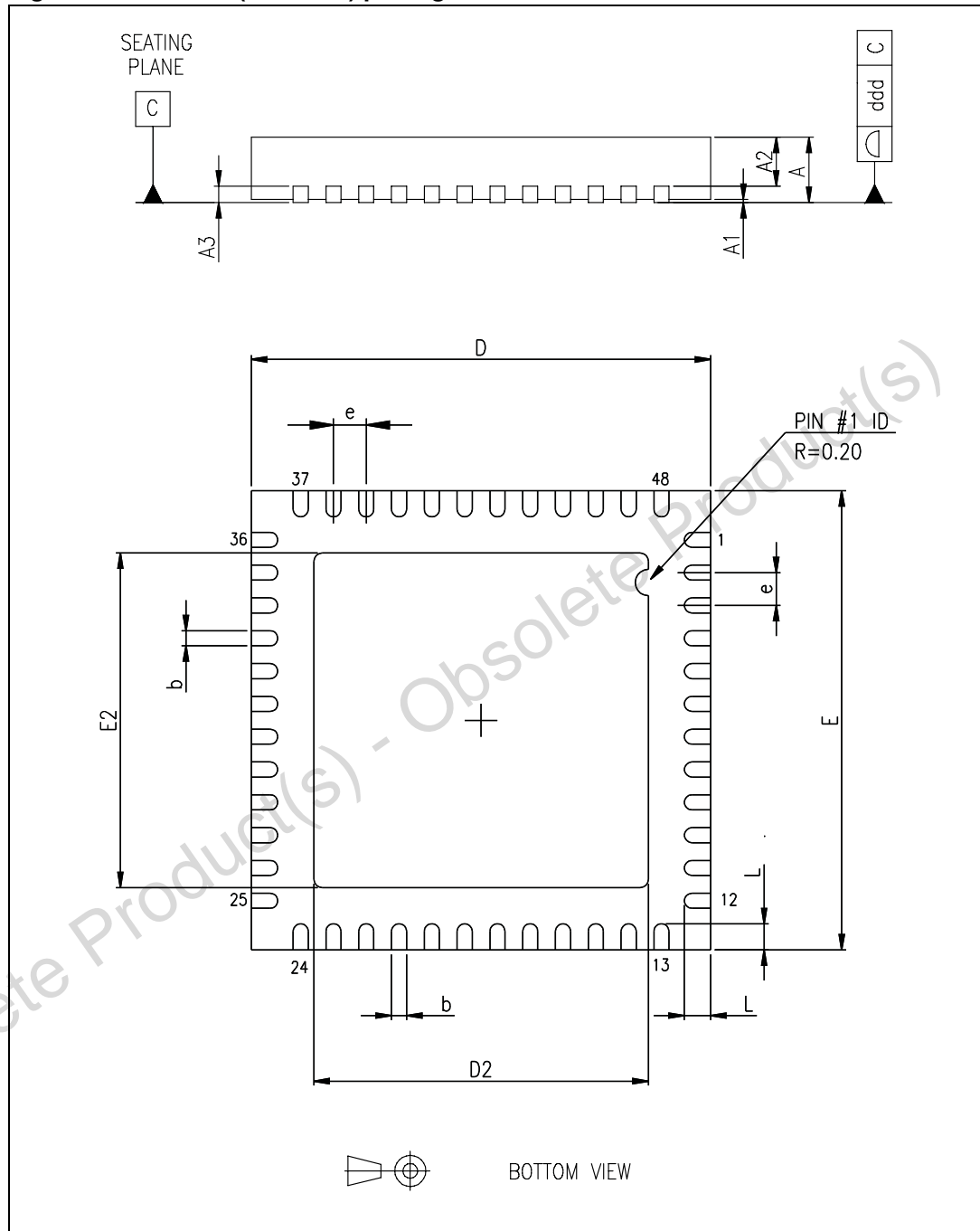

Table 15. QFN-48 (7 x 7 mm) package mechanical data

Symbol	Millimeters			Inches		
	Min	Typ	Max	Min	Typ	Max
A	0.80	0.90	1.00	0.80	0.85	1.00
A1		0.02	0.05		0.01	0.05
A2		0.65	1.00		0.65	
A3		0.25			0.20	
b	0.18	0.23	0.30	0.18	0.23	0.30
D	6.85	7.00	7.15	6.90	7.00	7.10
D2	2.25	4.70	5.25	See exposed pad variations		
E	6.85	7.00	7.15	6.90	7.00	7.10
E2	2.25	4.70	5.25	See exposed pad variations		
e	0.45	0.50	0.55	0.45	0.50	0.55
L	0.30	0.40	0.50	0.30	0.40	0.50
ddd			0.08			0.08

Figure 7. QFN-48 tape information

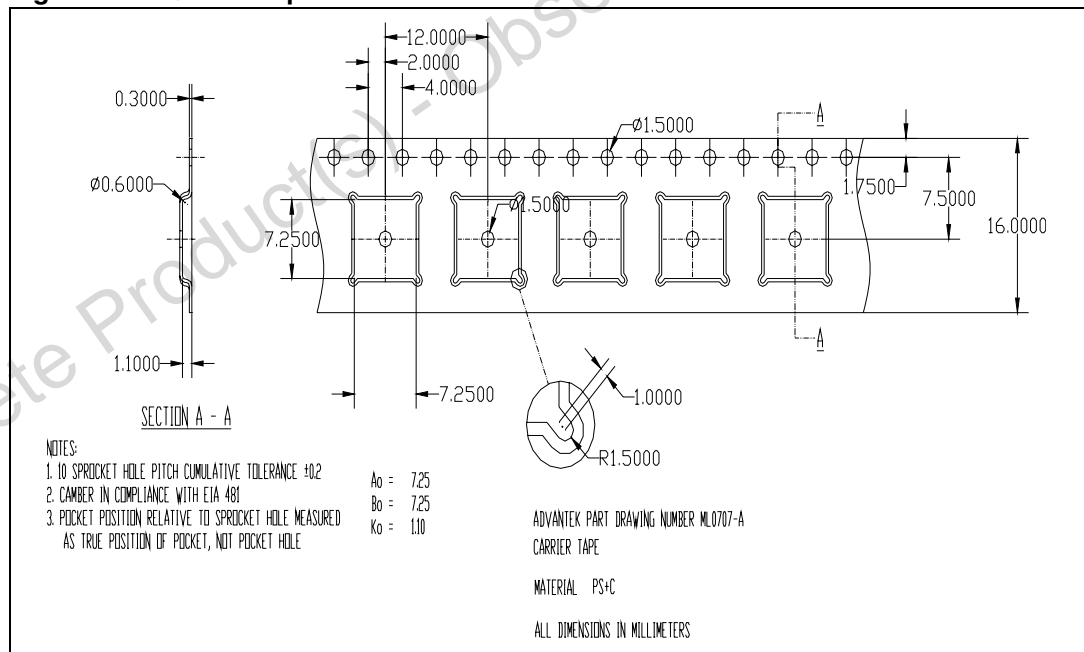
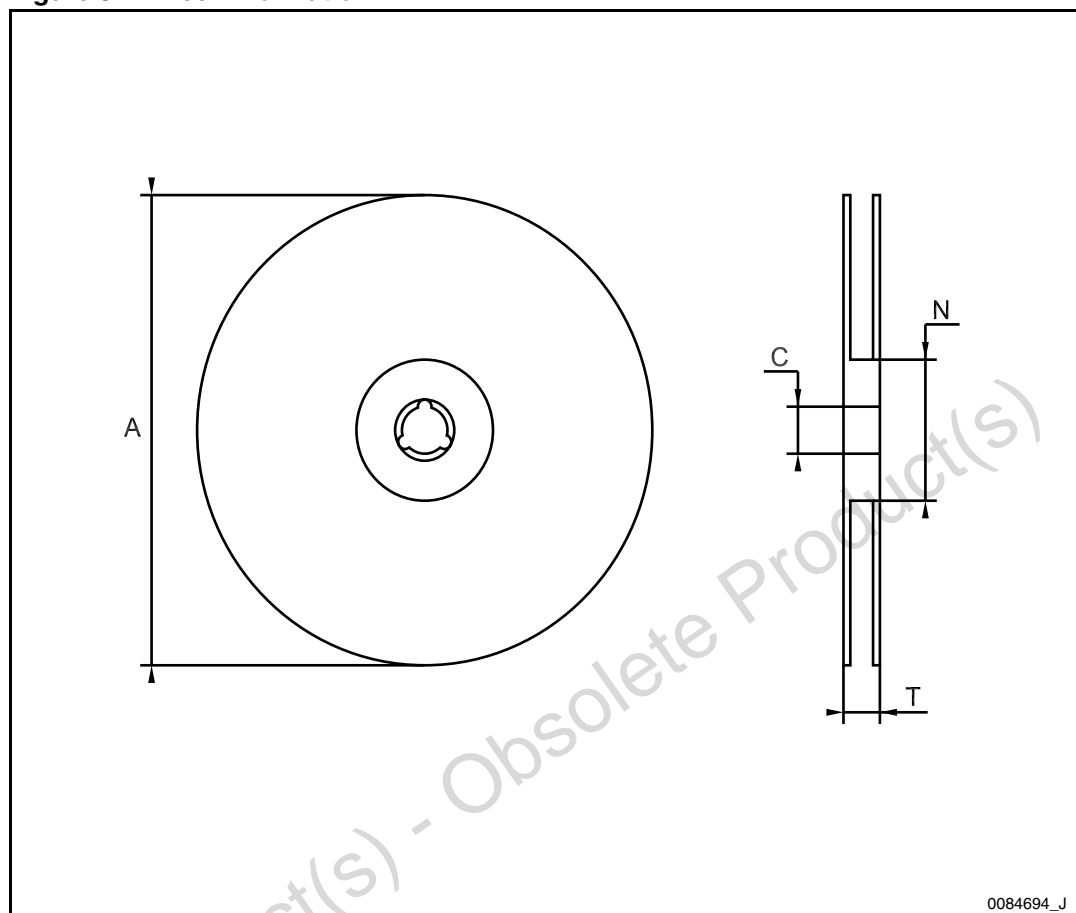

Figure 8. Reel information



0084694_J

Table 16. Reel mechanical data (dimensions in mm)

A	C	N	T
330.2	13 ±0.25	100	16.4

8 Revision history

Table 17. Document revision history

Date	Revision	Changes
15-Apr-2008	1	Initial release.
23-Apr-2008	2	Modified: Figure 5 .
10-Jun-2008	3	Document status promoted from preliminary data to datasheet.
01-Dec-2008	4	Updated: Features section, Table 2: Pin description on page 7 and Chapter 4 and Chapter 5: Maximum ratings on page 13 . Added: Figure 3: Cable adapter on page 4 , Figure 4: DP to HDMI/DVI cable adapter on page 5 , Figure 8: Reel information on page 23 and Table 16: Reel mechanical data (dimensions in mm) on page 23 .

Please Read Carefully:

Information in this document is provided solely in connection with ST products. STMicroelectronics NV and its subsidiaries ("ST") reserve the right to make changes, corrections, modifications or improvements, to this document, and the products and services described herein at any time, without notice.

All ST products are sold pursuant to ST's terms and conditions of sale.

Purchasers are solely responsible for the choice, selection and use of the ST products and services described herein, and ST assumes no liability whatsoever relating to the choice, selection or use of the ST products and services described herein.

No license, express or implied, by estoppel or otherwise, to any intellectual property rights is granted under this document. If any part of this document refers to any third party products or services it shall not be deemed a license grant by ST for the use of such third party products or services, or any intellectual property contained therein or considered as a warranty covering the use in any manner whatsoever of such third party products or services or any intellectual property contained therein.

UNLESS OTHERWISE SET FORTH IN ST'S TERMS AND CONDITIONS OF SALE ST DISCLAIMS ANY EXPRESS OR IMPLIED WARRANTY WITH RESPECT TO THE USE AND/OR SALE OF ST PRODUCTS INCLUDING WITHOUT LIMITATION IMPLIED WARRANTIES OF MERCHANTABILITY, FITNESS FOR A PARTICULAR PURPOSE (AND THEIR EQUIVALENTS UNDER THE LAWS OF ANY JURISDICTION), OR INFRINGEMENT OF ANY PATENT, COPYRIGHT OR OTHER INTELLECTUAL PROPERTY RIGHT.

UNLESS EXPRESSLY APPROVED IN WRITING BY AN AUTHORIZED ST REPRESENTATIVE, ST PRODUCTS ARE NOT RECOMMENDED, AUTHORIZED OR WARRANTED FOR USE IN MILITARY, AIR CRAFT, SPACE, LIFE SAVING, OR LIFE SUSTAINING APPLICATIONS, NOR IN PRODUCTS OR SYSTEMS WHERE FAILURE OR MALFUNCTION MAY RESULT IN PERSONAL INJURY, DEATH, OR SEVERE PROPERTY OR ENVIRONMENTAL DAMAGE. ST PRODUCTS WHICH ARE NOT SPECIFIED AS "AUTOMOTIVE GRADE" MAY ONLY BE USED IN AUTOMOTIVE APPLICATIONS AT USER'S OWN RISK.

Resale of ST products with provisions different from the statements and/or technical features set forth in this document shall immediately void any warranty granted by ST for the ST product or service described herein and shall not create or extend in any manner whatsoever, any liability of ST.

ST and the ST logo are trademarks or registered trademarks of ST in various countries.

Information in this document supersedes and replaces all information previously supplied.

The ST logo is a registered trademark of STMicroelectronics. All other names are the property of their respective owners.

© 2008 STMicroelectronics - All rights reserved

STMicroelectronics group of companies

Australia - Belgium - Brazil - Canada - China - Czech Republic - Finland - France - Germany - Hong Kong - India - Israel - Italy - Japan - Malaysia - Malta - Morocco - Singapore - Spain - Sweden - Switzerland - United Kingdom - United States of America

www.st.com