

TLE4923

Dynamic Differential Hall Effect Sensor IC

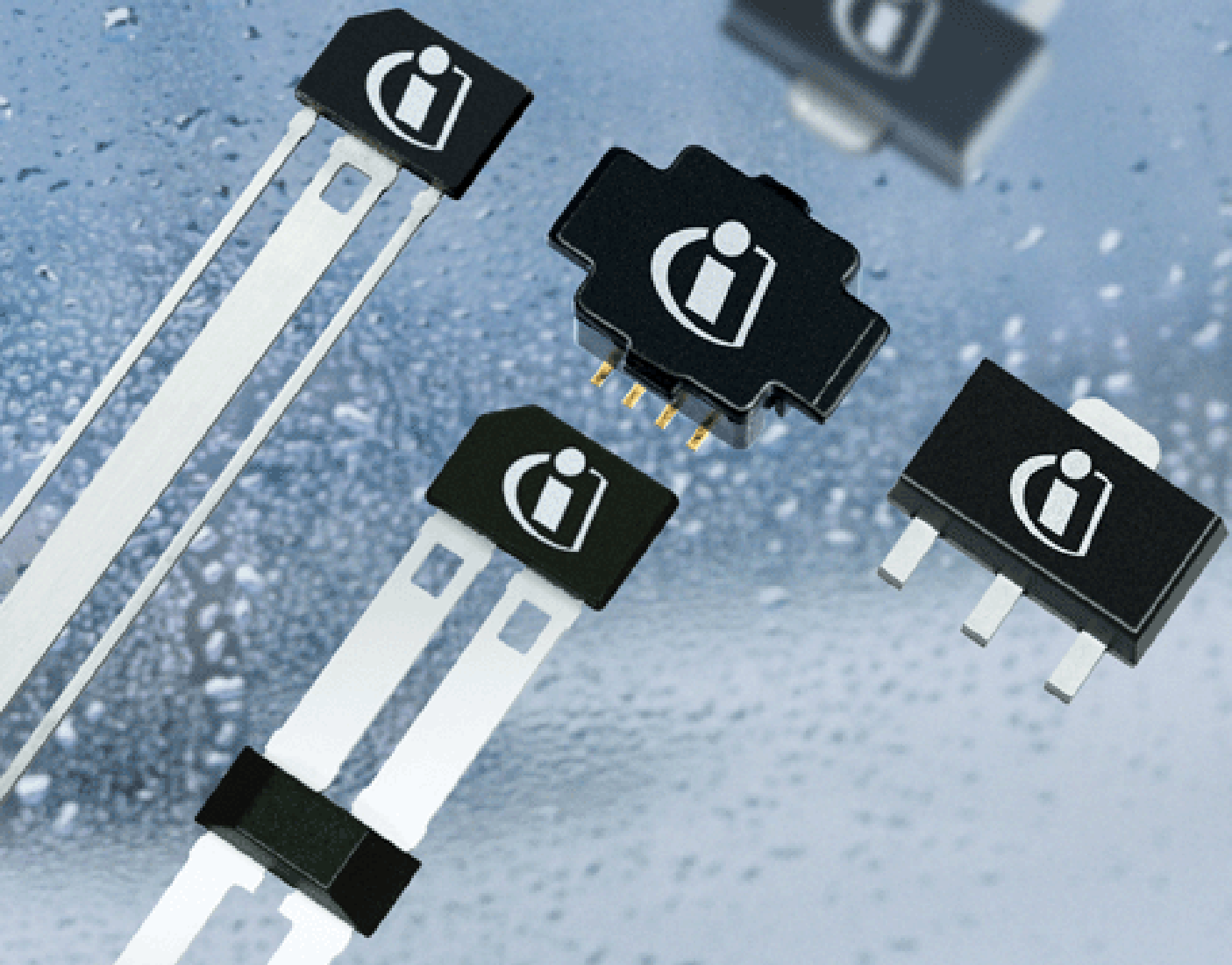

Sensors



Never stop thinking.

Edition 2005-04

**Published by Infineon Technologies AG,
St.-Martin-Strasse 53,
81669 München, Germany**

**© Infineon Technologies AG 2005.
All Rights Reserved.**

Attention please!

The information herein is given to describe certain components and shall not be considered as a guarantee of characteristics.

Terms of delivery and rights to technical change reserved.

We hereby disclaim any and all warranties, including but not limited to warranties of non-infringement, regarding circuits, descriptions and charts stated herein.

Information

For further information on technology, delivery terms and conditions and prices please contact your nearest Infineon Technologies Office (www.infineon.com).

Warnings

Due to technical requirements components may contain dangerous substances. For information on the types in question please contact your nearest Infineon Technologies Office.

Infineon Technologies Components may only be used in life-support devices or systems with the express written approval of Infineon Technologies, if a failure of such components can reasonably be expected to cause the failure of that life-support device or system, or to affect the safety or effectiveness of that device or system. Life support devices or systems are intended to be implanted in the human body, or to support and/or maintain and sustain and/or protect human life. If they fail, it is reasonable to assume that the health of the user or other persons may be endangered.

Revision History: 2005-04

V 1.0

Previous Version: none

Page	Subjects (major changes since last revision)

We Listen to Your Comments

Any information within this document that you feel is wrong, unclear or missing at all? Your feedback will help us to continuously improve the quality of this document.

Please send your proposal (including a reference to this document) to:

feedback.sensors@infineon.com

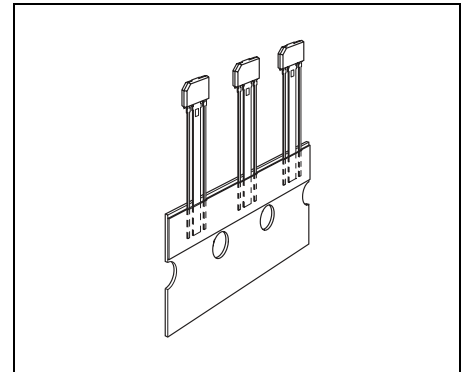

Table of Contents		Page
1	Overview	5
1.1	Features	5
1.2	Pin Configuration (top view)	6
2	General	7
2.1	Block Diagram	7
2.2	Functional Description	8
2.3	Circuit Description (see Figure 2)	8
3	Maximum Ratings	9
4	Operating Range	10
5	Electrical Parameters	11
6	Application Notes	15
7	Typical Performance Characteristics	19
8	Package Outlines	23

1 Overview

1.1 Features

- Advanced performance
- Higher sensitivity
- Symmetrical thresholds
- High piezo resistivity
- Reduced power consumption
- South and north pole pre-induction possible
- AC coupled
- Digital output signal
- Two-wire interface
- Large temperature range
- Large airgap
- Low cut-off frequency
- Protection against reversed polarity



The differential Hall effect sensor TLE4923 is compatible to the TLE4921-3U, except for having a 2-wire interface. The TLE4923 provides high sensitivity, a superior stability over temperature and symmetrical thresholds in order to achieve a stable duty cycle. TLE4923 is particularly suitable for rotational speed detection and timing applications of ferromagnetic toothed wheels such as in anti-lock braking systems, transmissions, crankshafts, etc. The integrated circuit (based on Hall effect) provides a digital signal output with frequency proportional to the speed of rotation. Unlike other rotational sensors differential Hall ICs are not influenced by radial vibration within the effective airgap of the sensor and require no external signal processing.

Type	Marking	Ordering Code	Package
TLE4923	4923 B	Q62705-K408	PG-SSO-3-6

1.2 Pin Configuration (top view)

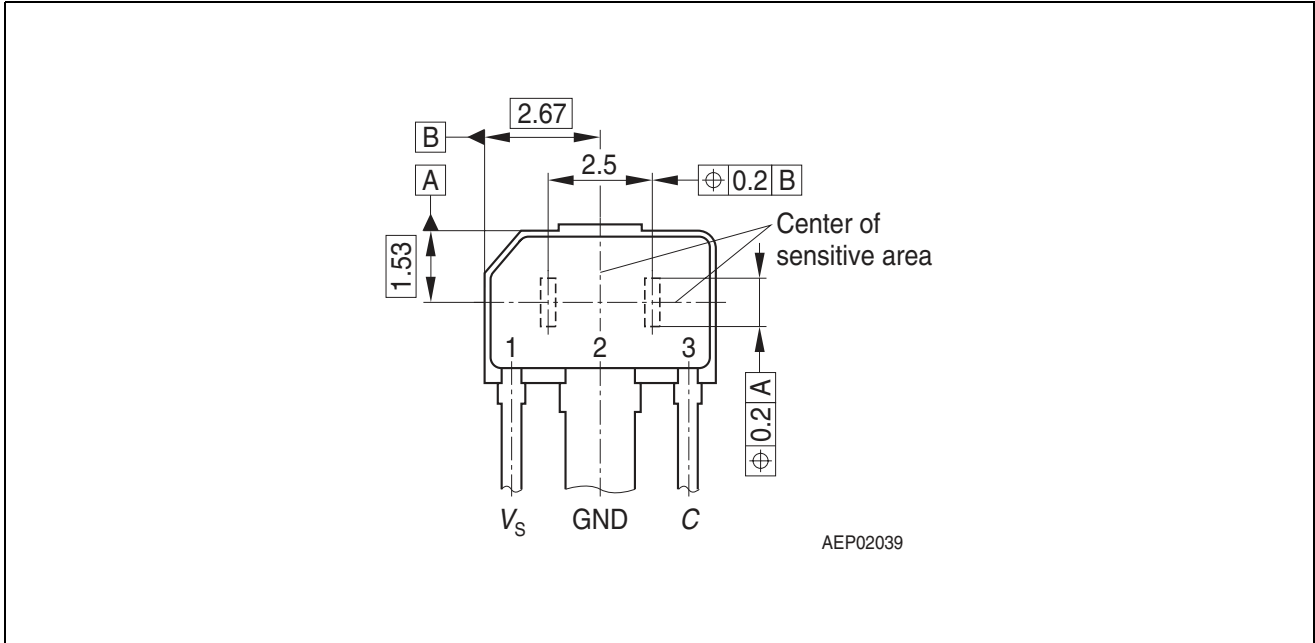

Figure 1

Table 1 Pin Definitions and Functions

Pin No.	Symbol	Function
1	V_S	Supply voltage
2	GND	Ground
3	C	Capacitor

2 General

2.1 Block Diagram

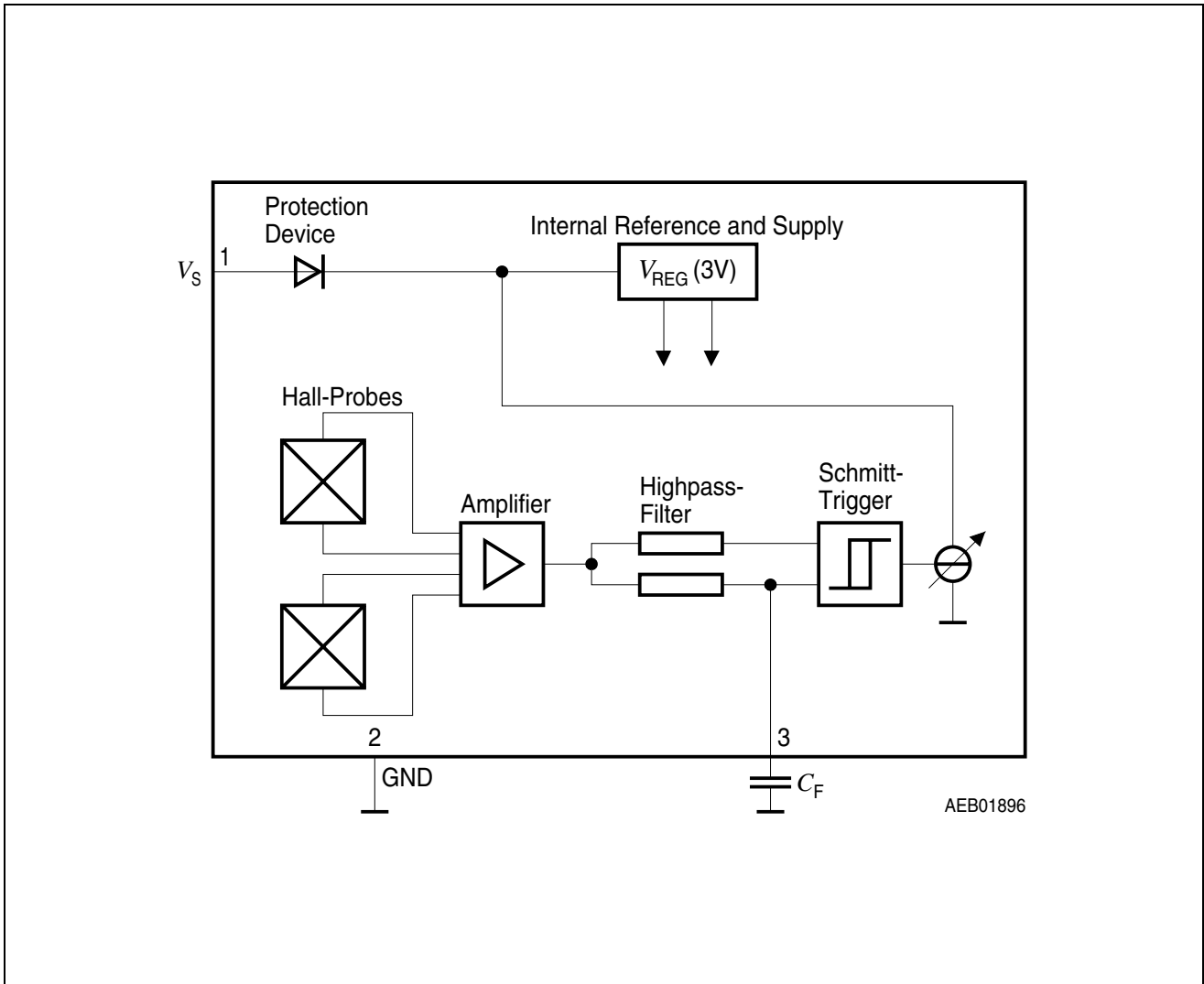

Figure 2 Block Diagram

2.2 Functional Description

The Differential Hall sensor IC detects the motion and position of ferromagnetic and permanent magnet structures by measuring the differential flux density of the magnetic field. To detect ferromagnetic objects the magnetic field must be provided by a back biasing permanent magnet (**south or north** pole of the magnet attached to the rear unmarked side of the IC package).

Using an external capacitor the generated Hall voltage signal is slowly adjusted via an active high pass filter with low frequency cut-off. This causes the output to switch into a biased mode after a time constant is elapsed. The time constant is determined by the external capacitor. Filtering avoids aging and temperature influence from Schmitt-trigger input and eliminates device and magnetic offset.

The TLE4923 can be exploited to detect toothed wheel rotation in a rough environment. Jolts against the toothed wheel and ripple have no influence on the output signal.

The on and off state of the IC are indicated by high and low current consumption.

2.3 Circuit Description (see [Figure 2](#))

The TLE4923 is comprised of a supply voltage reference, a pair of Hall probes spaced at 2.5 mm, differential amplifier, filter for offset compensation, Schmitt-trigger, and a switched current source.

The TLE4923 was designed to have a wide range of application parameter variations. Differential fields up to ± 40 mT can be detected without influence to the switching performance. The pre-induction field can either come from a magnetic south or north pole, whereby the field strength up to 500 mT or more will not influence the switching points¹⁾. The improved temperature compensation enables a superior sensitivity and accuracy over the temperature range. Finally, the optimized piezo compensation and the integrated dynamic offset compensation enable easy manufacturing and elimination of magnet offsets.

Protection is provided at the input/supply (pin 1) for reverse polarity.

1) Differential bias fields exceeding ± 20 mT, e. g. caused by a misaligned magnet, should be avoided.

3 Maximum Ratings

Table 2 Absolute Maximum Ratings

Parameter	Symbol	Limit Values		Unit	Remarks
		min.	max.		
Supply voltage	V_S	-18 ¹⁾	24	V	
Capacitor voltage	V_C	-0.3	3	V	
Junction temperature	T_j	–	150	°C	5000 h
		–	160		2500 h
		–	170		500 h
		–	190		4 h
Storage temperature	T_S	-40	150	°C	
Thermal resistance	R_{thJA}	–	190	K/W	²⁾

1) Reverse current drawn by the device < 10 mA

2) Can be reduced significantly by further packaging process, e. g. overmolding.
The device is ESD protected up to 2 kV (HL test procedure)

Note: Stresses above those listed here may cause permanent damage to the device. Exposure to absolute maximum rating conditions for extended periods may affect device reliability.

4 Operating Range

Table 3 Operating Range

Parameter	Symbol	Limit Values			Unit	Conditions
		min.	typ.	max.		
Supply voltage	V_S	4.5	–	18	V	
Junction temperature	T_j	-40	–	150	°C	5000 h
		–	–	160		2500 h
		–	–	170		500 h
		–	–	190		4 h
Pre-induction	B_0	-500	–	500	mT	At Hall probe; independent of magnet orientation
Differential induction	ΔB	-40	–	40	mT	

*Note: Unless otherwise noted, all temperatures refer to junction temperature.
In the operating range the functions given in the circuit description are fulfilled.*

5 Electrical Parameters

Table 4 Electrical Characteristics

The device characteristics listed below are guaranteed in the full operating range.

Parameter	Symbol	Limit Values			Unit	Test Condition	Test Circuit
		min.	typ.	max.			
Supply current	I_S	3.1	4.1	5.3	mA		1
		8.1	10.5	13.6	mA		1
Supply current difference	$I_{SON} - I_{SOFF}$	5.0	6.4	8.3	mA		1
Supply current ratio	I_{SON} / I_{SOFF}	2	2.4	3			1
Center of switching points: ($\Delta B_{OP} + \Delta B_{RP}$) / 2	ΔB_m	-0.5	0	0.5	mT	$\Delta B = 2.0$ mT, $f = 200$ Hz, $-40^\circ\text{C} < T_j \leq 150^\circ\text{C}$ ^{1) 2)}	2
Center of switching points: ($\Delta B_{OP} + \Delta B_{RP}$) / 2	ΔB_m	-0.7	0	0.7	mT	$\Delta B = 2.0$ mT, $f = 200$ Hz, $150^\circ\text{C} < T_j < 190^\circ\text{C}$ ^{1) 2)}	2
Hysteresis	ΔB_H	1	1.5	2.2	mT	$\Delta B = 2.0$ mT, $f = 200$ Hz ³⁾	2
Current rise time	t_r	–	–	0.5	μs		2
Current fall time	t_f	–	–	0.5	μs		2
Delay time ⁴⁾	t_{dop}			25	μs	$f = 10$ kHz, $\Delta B = 5$ mT	2
	t_{drp}			10	μs		
	$t_{dop} - t_{drp}$			15	μs		
Filter input resistance	R_C	35	43	52	k Ω	$25^\circ\text{C} \pm 2^\circ\text{C}$	1
Filter sensitivity to ΔB	S_C		8.5		mV/ mT	$25^\circ\text{C} \pm 2^\circ\text{C}$	1
Filter bias voltage	V_C	1.6	2.0	2.4	V	$\Delta B = 0$	1
Frequency	f	⁵⁾		10000	Hz	$\Delta B = 5$ mT	2

Electrical Parameters

Table 4 Electrical Characteristics (cont'd)

The device characteristics listed below are guaranteed in the full operating range.

Parameter	Symbol	Limit Values			Unit	Test Condition	Test Circuit
		min.	typ.	max.			
Resistivity against mechanical stress (piezo) ⁶⁾	ΔB_m	-0.1	–	0.1	mT	F = 2 N	2
	ΔB_H	-0.1	–	0.1	mT		
Power supply rejection ratio (PSRR)	V_{PSRR}	10	–	–	V	V_S modulated with V_{PSRR} , $f_{PSRR} = 10$ kHz, $t_{r,fPSRR} = 1$ μ s, $\Delta B = 0$, only 1 transition may occur	2 ⁷⁾

- 1) For ΔB values larger than ± 10 mT this value may exceed the limits as follows: $|\Delta B_m| < |0.05 \times \Delta B|$
- 2) Leakage currents at pin 3 should be avoided. The bias shift of B_m caused by a leakage current I_L can be calculated by: $\Delta B_m = \frac{I_L \times R_C(T)}{S_C(T)}$. See also the typical curves on [Page 22](#).
- 3) Differential pre-induction (e.g. by magnetic misalignment) has to be smaller than 20 mT.
- 4) For definition see [Figure 6](#).
- 5) Depends on filter capacitor C_F . The cut-off frequency is given as $f = \frac{1}{2 \times \pi \times R_C \times C_F}$. The switching points are guaranteed over the whole frequency range, but amplitude modification and phase shift have to be taken into account due to the 1st order highpass filter.
- 6) For definition see [Figure 7](#).
- 7) For definition see [Figure 5](#).

Note: The listed characteristics are ensured over the operating range of the integrated circuit. Typical characteristics specify mean values expected over the production spread. If not otherwise specified, typical characteristics apply at $T_j = 25^\circ\text{C}$ and the given supply voltage.

Electrical Parameters

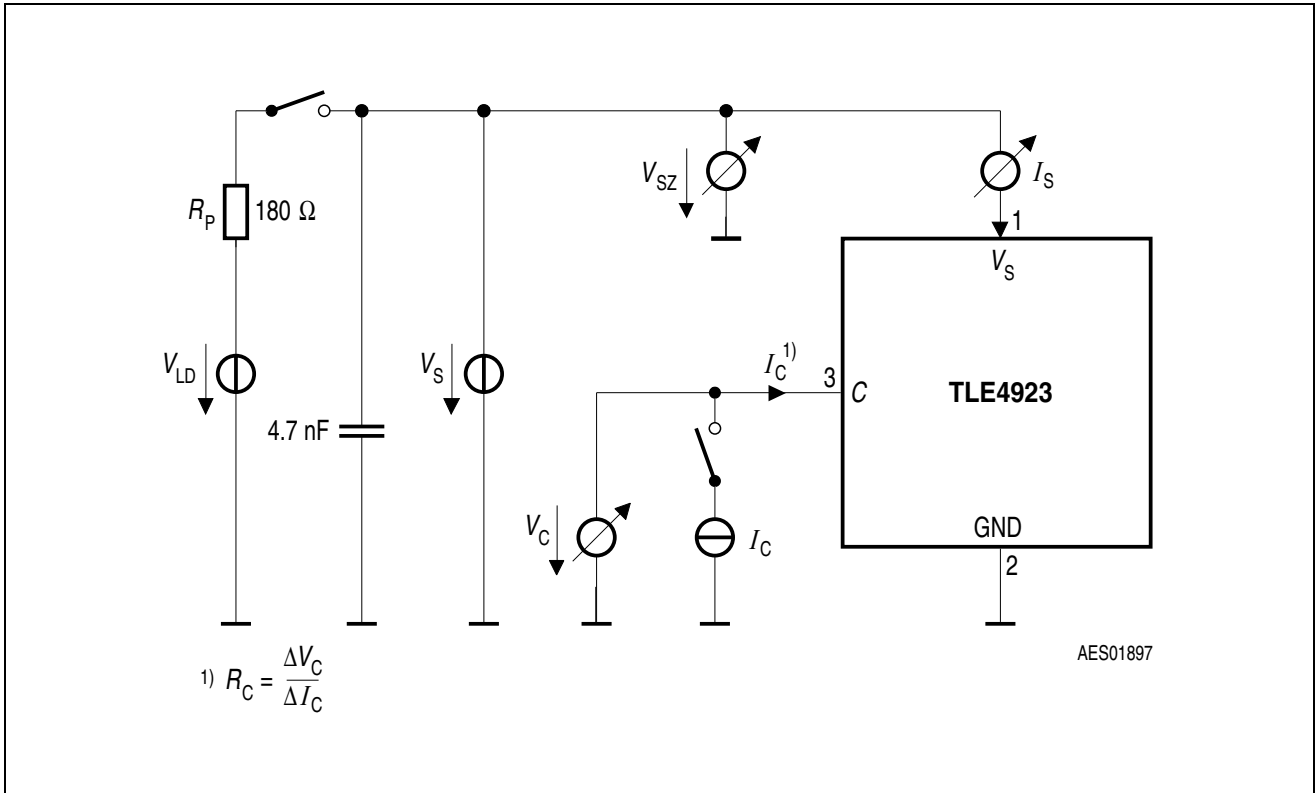

Figure 3 Test Circuit 1

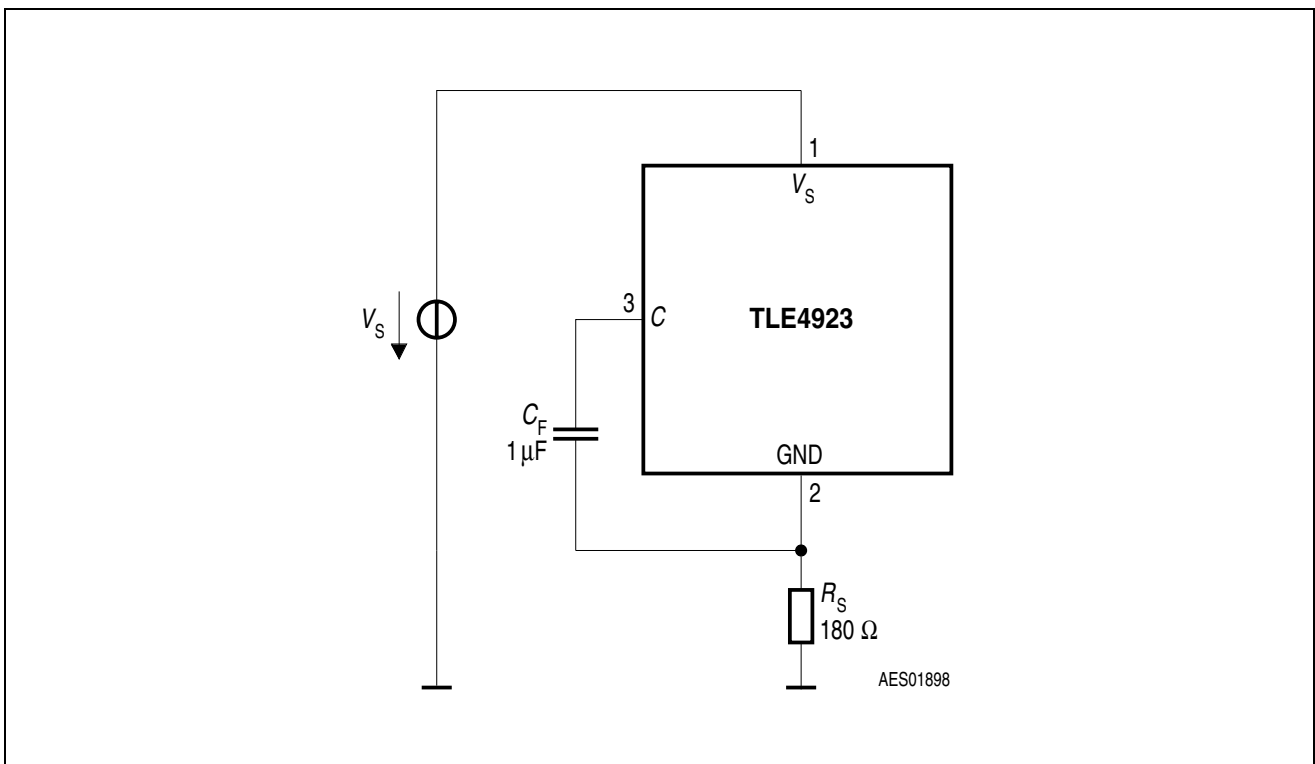

Figure 4 Test Circuit 2

Electrical Parameters

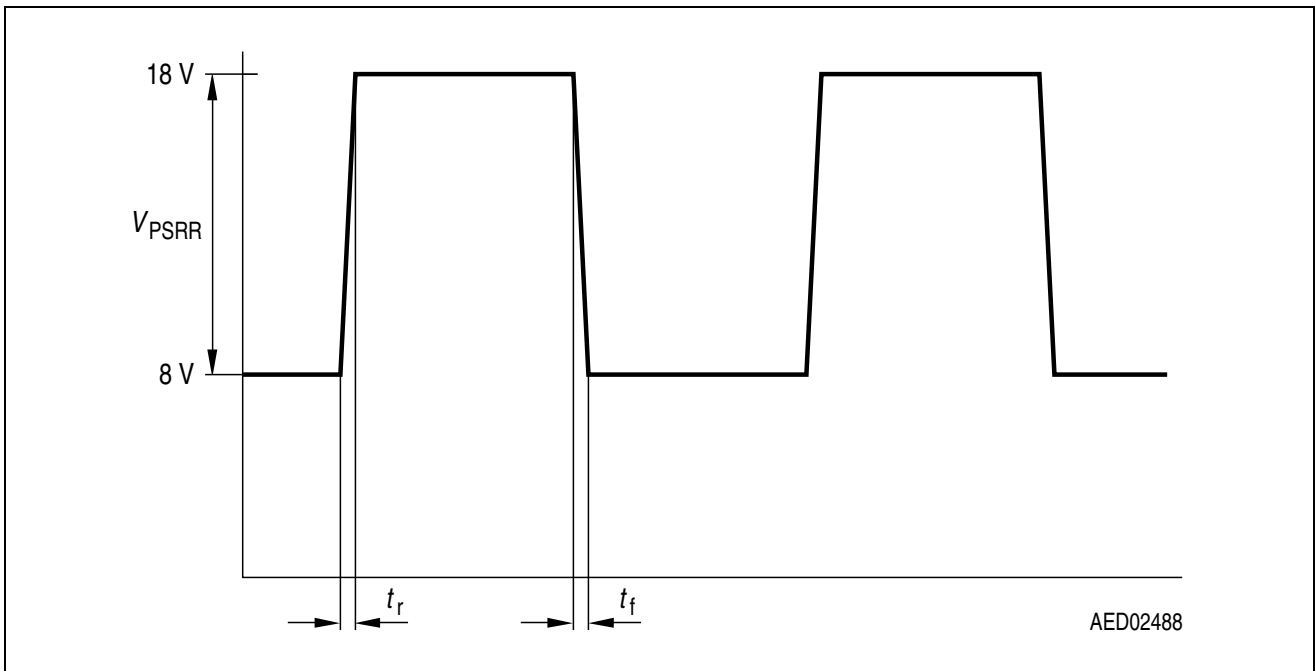

Figure 5

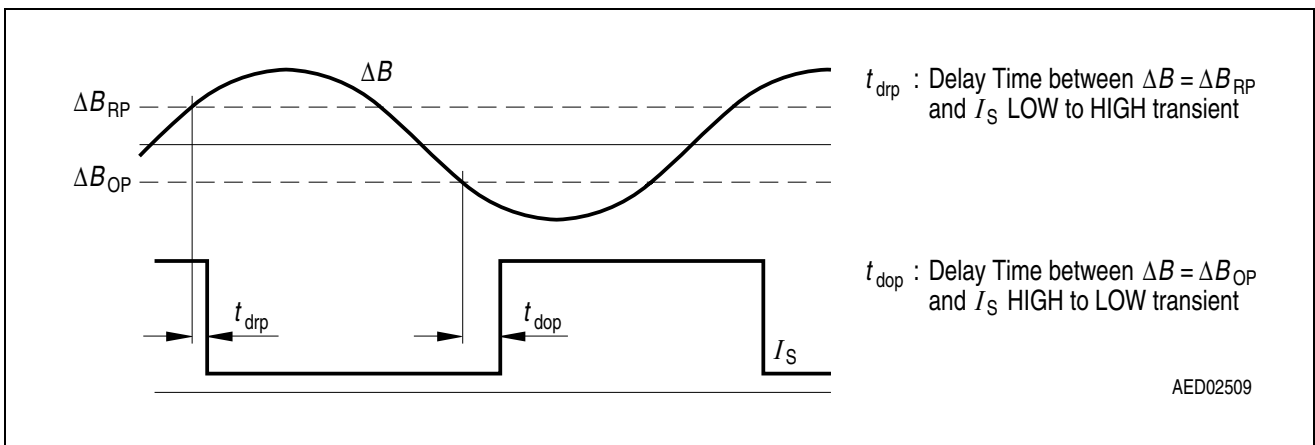

Figure 6 Definition of Delay Times (switching points related to initial measurement @ $\Delta B = 2 \text{ mT}$; $f = 200 \text{ Hz}$)

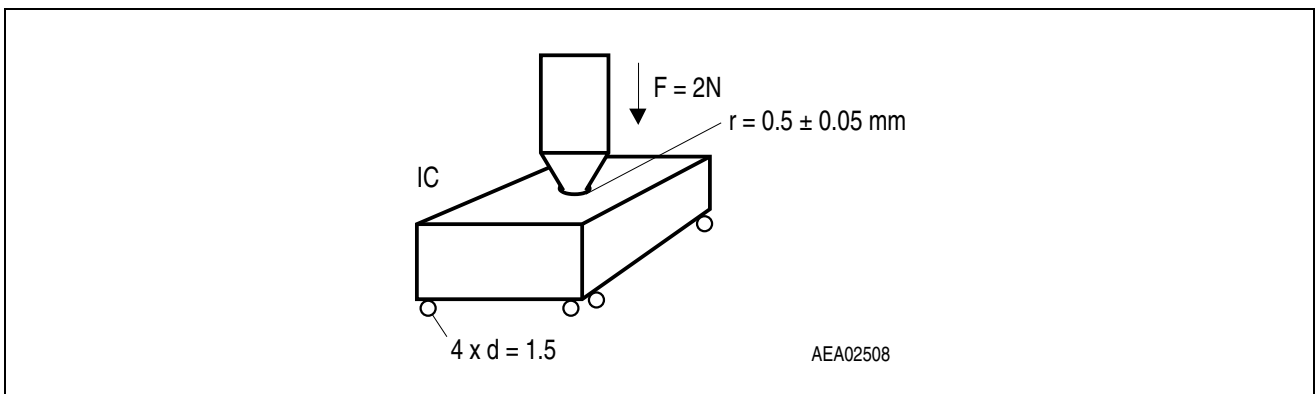

Figure 7 Setup for Piezo Measurements

6 Application Notes

Two possible applications are shown in [Figure 10](#) and [Figure 11](#) (Toothed and Magnet Wheel).

Two-wire application is shown in [Figure 12](#).

Gear Tooth Sensing

In the case of ferromagnetic toothed wheel applications the IC has to be biased by the south or north pole of a permanent magnet (e.g. SmCo₅ (Vacuumschmelze VX170) with the dimensions 8 mm × 5 mm × 3 mm) which should cover both Hall probes.

The maximum air gap depends on:

- the magnetic field strength (magnet used; pre-induction) and
- the tooth wheel that is used (dimensions, material, etc.; resulting differential field).

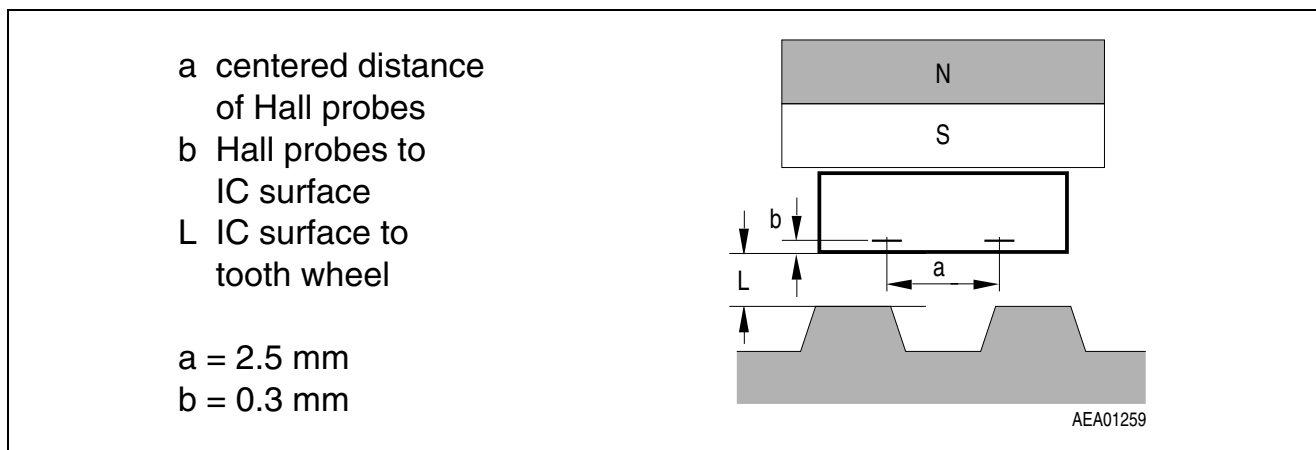

Figure 8 Sensor Spacing

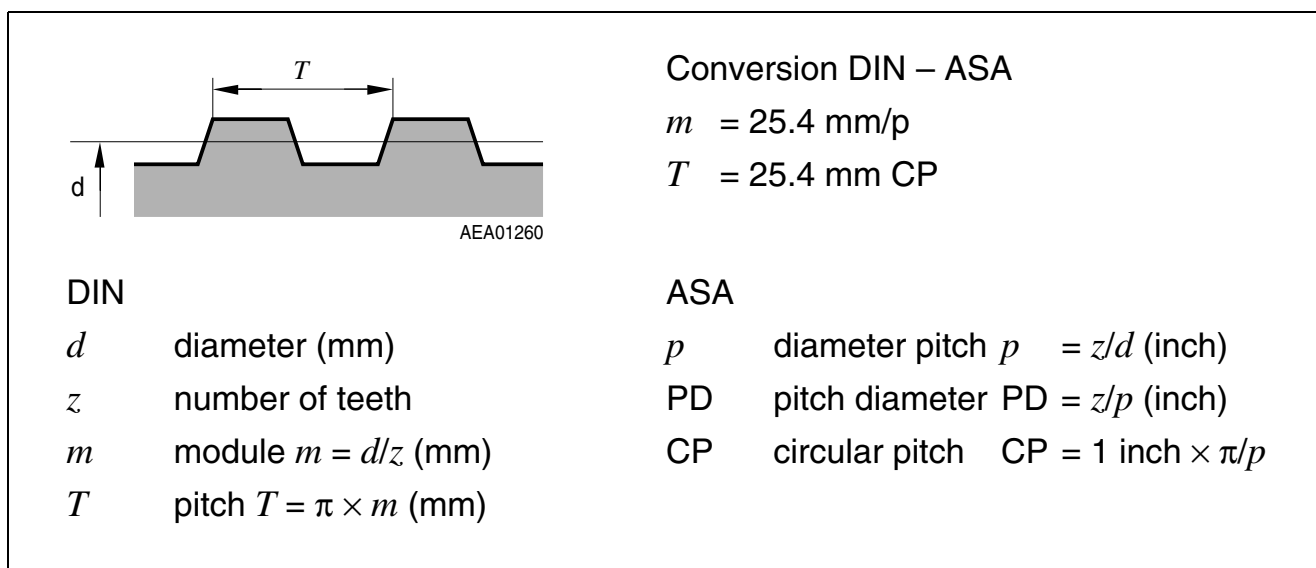

Figure 9 Tooth Wheel Dimensions

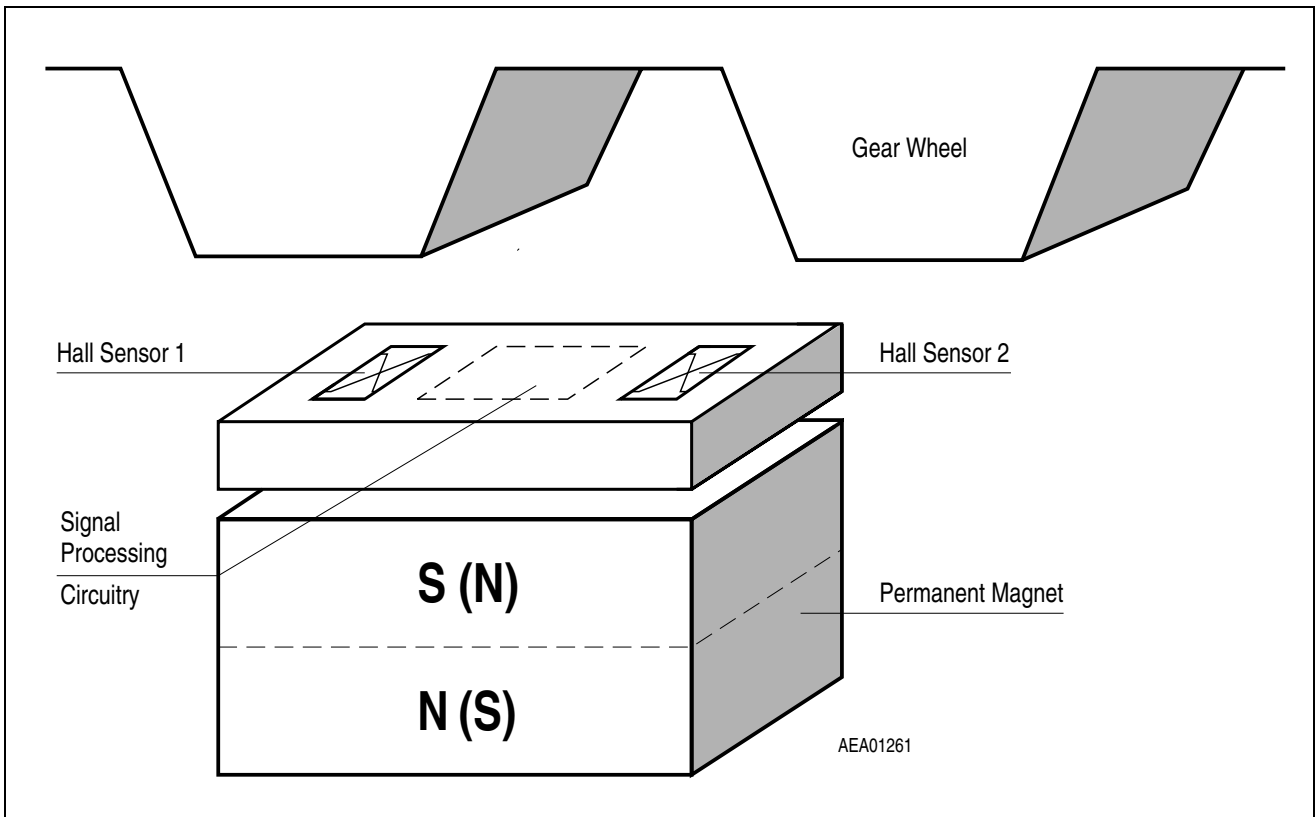

Figure 10 TLE4923, with Ferromagnetic Toothed Wheel

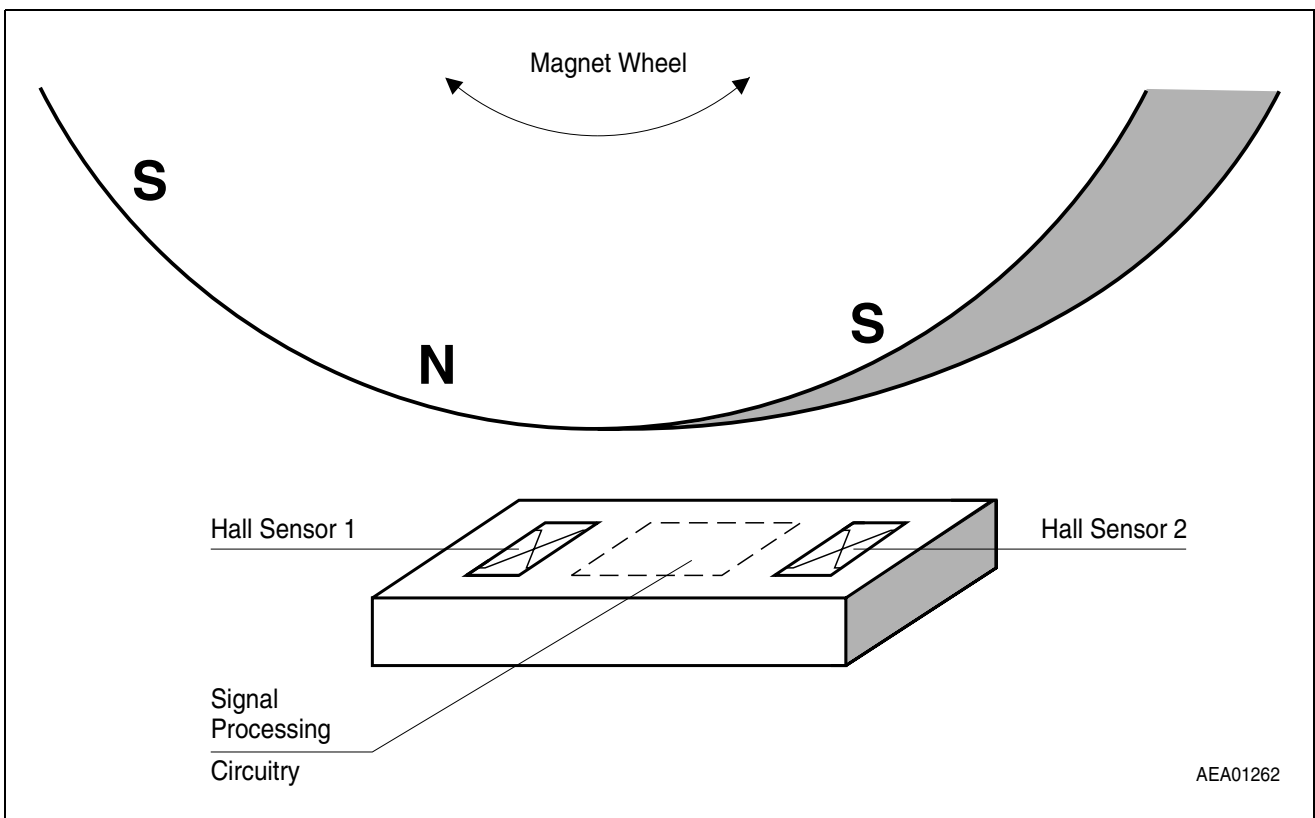

Figure 11 TLE4923, with Magnet Wheel

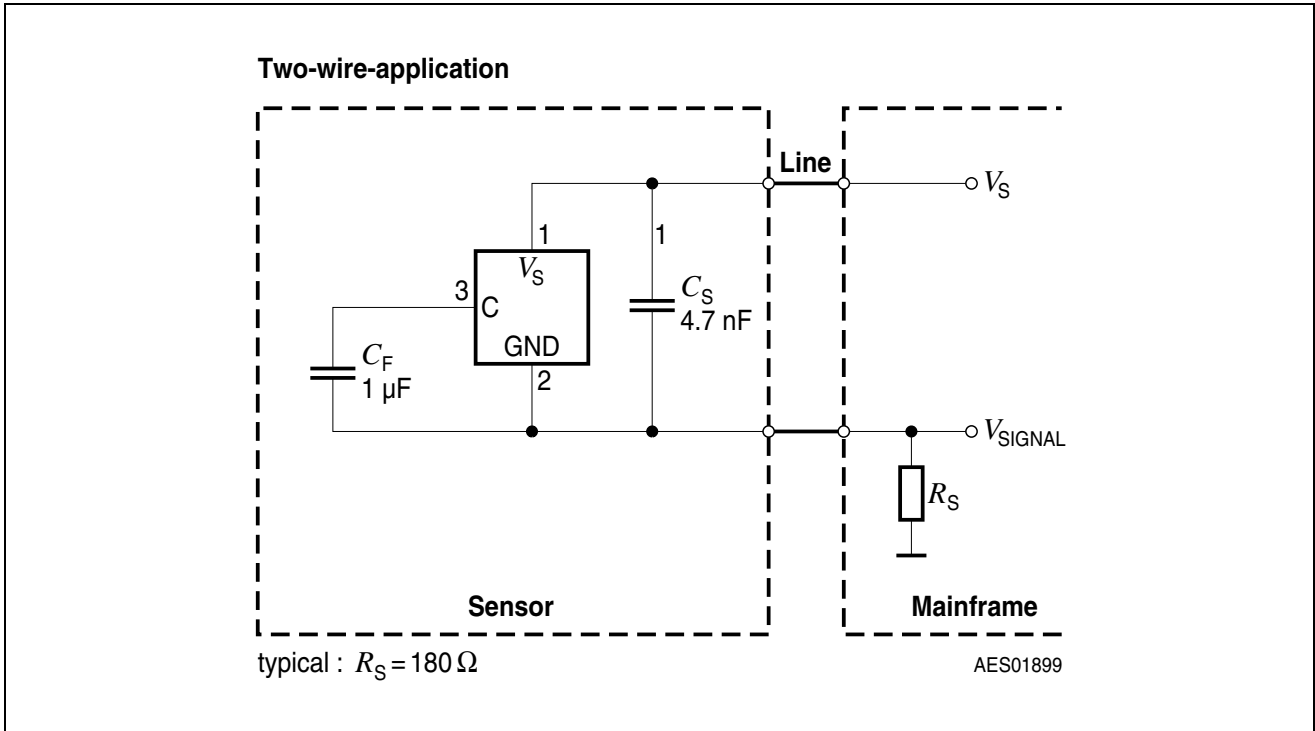

Figure 12 Application Circuit

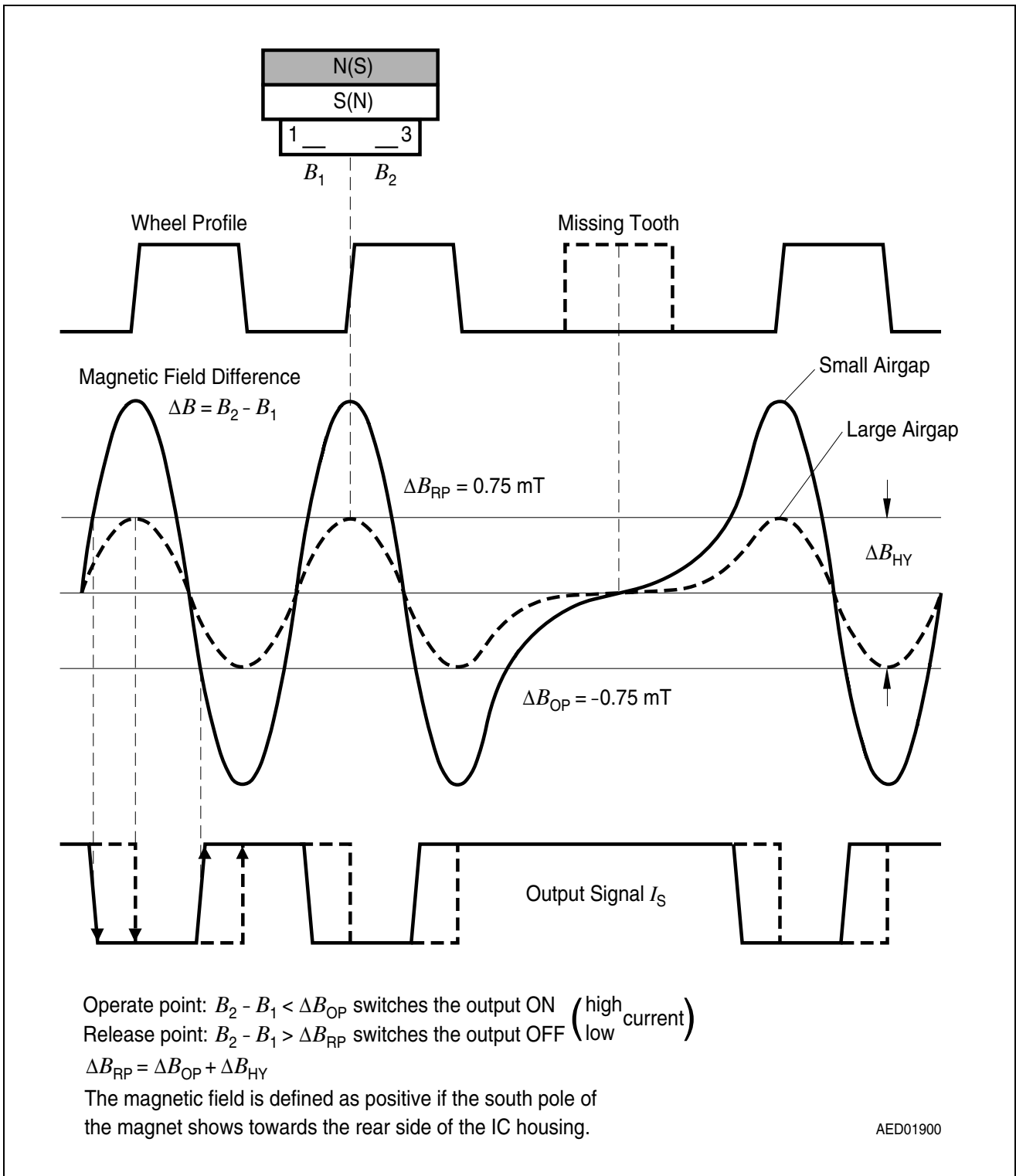

Figure 13 System Operation

Typical Performance Characteristics

7 Typical Performance Characteristics

If not otherwise specified, all curves reflect typical values at $T_j = 25^\circ\text{C}$ and $V_S = 12\text{ V}$.

Supply Current and Supply Current Difference versus Supply Voltage

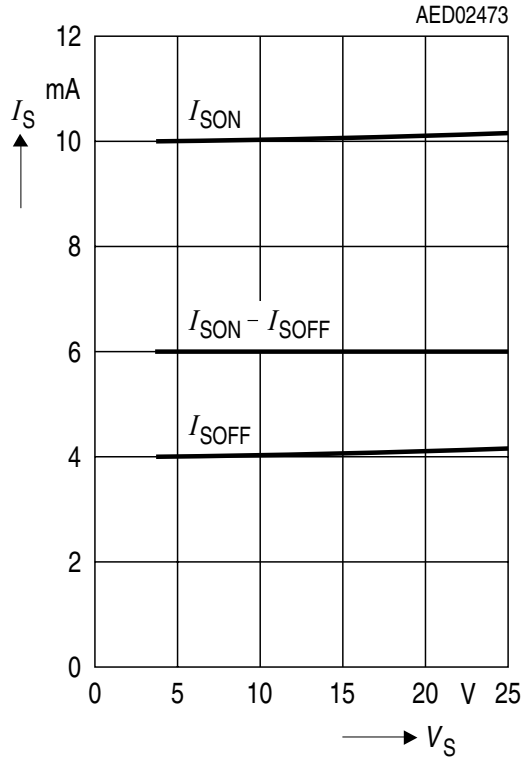

Minimum Switching Field versus Frequency

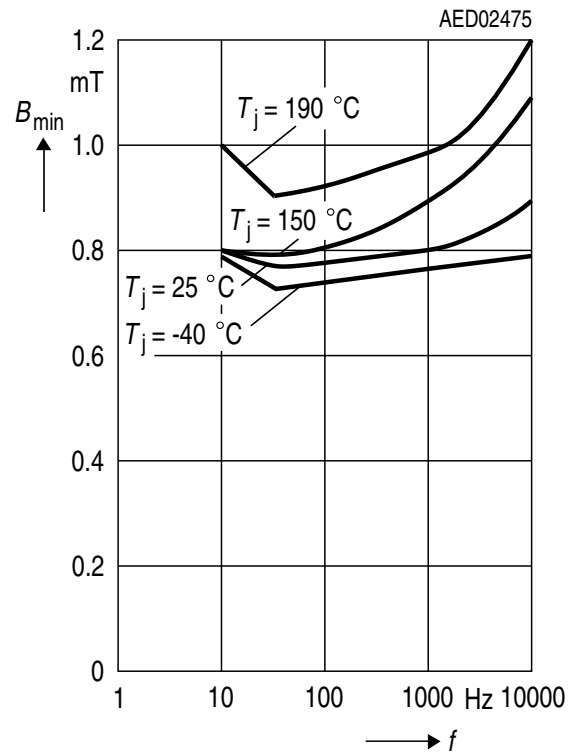

Supply Current and Supply Current Difference versus Temperature

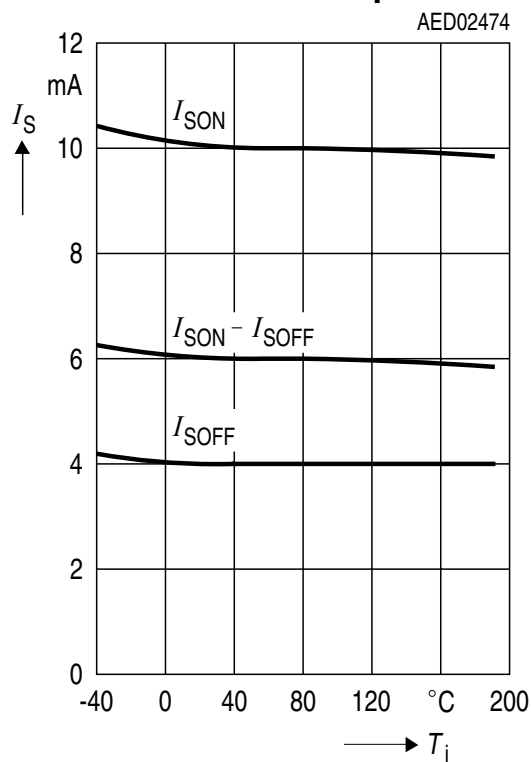

Mean Value of Switching Induction

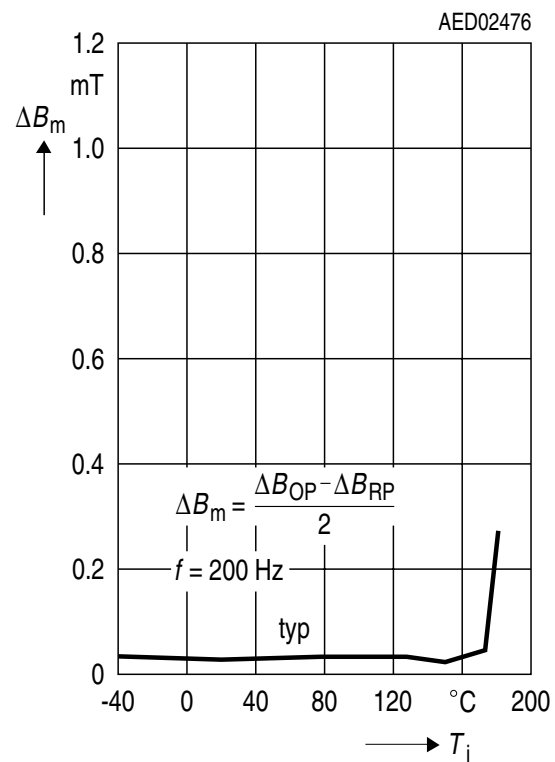

Typical Performance Characteristics

Hysteresis versus Temperature

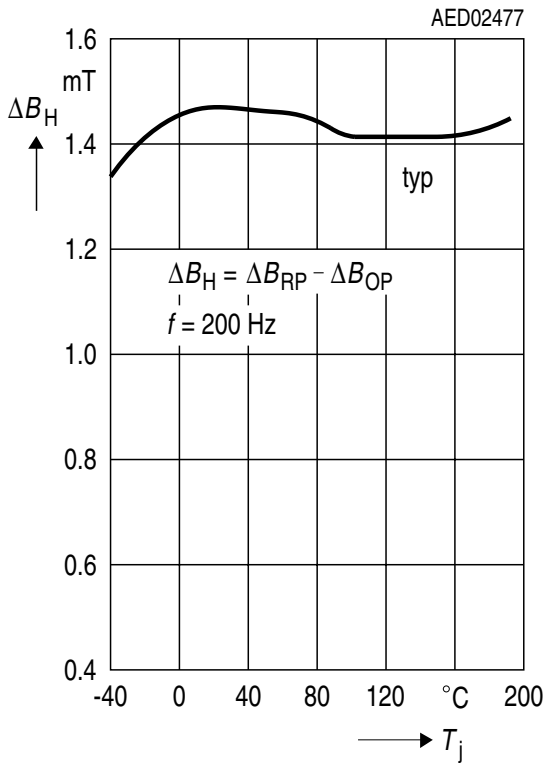

Delay Time ¹⁾ versus Temperature

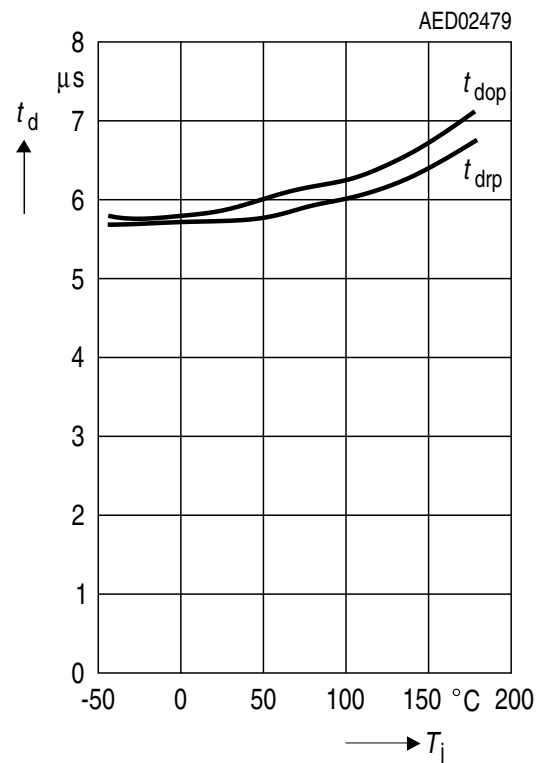

Delay Time ¹⁾ versus Differential Field

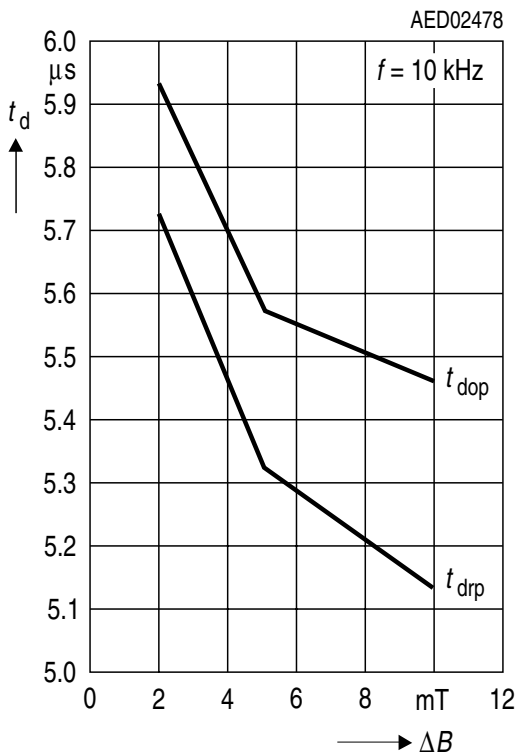

Rise and Fall Time versus Temperature

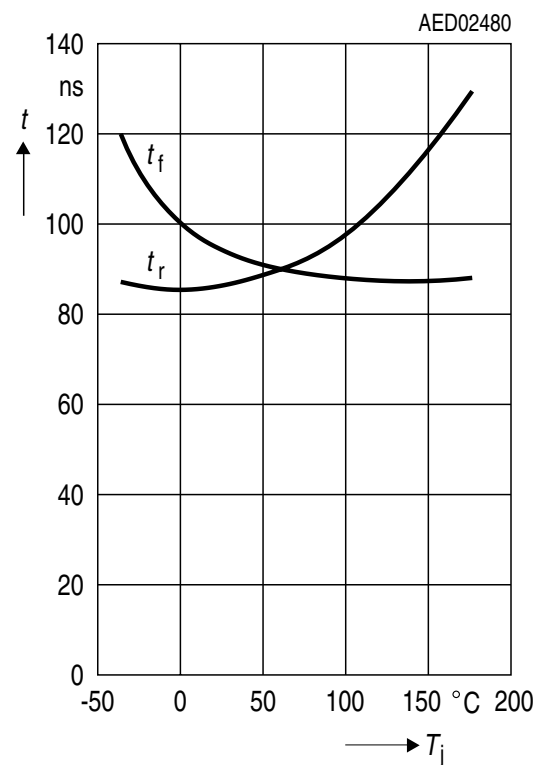

1) Switching points related to initial measurement @ $\Delta B = 2 \text{ mT}$, $f = 200 \text{ Hz}$

Typical Performance Characteristics

Capacitor Voltage versus Temperature

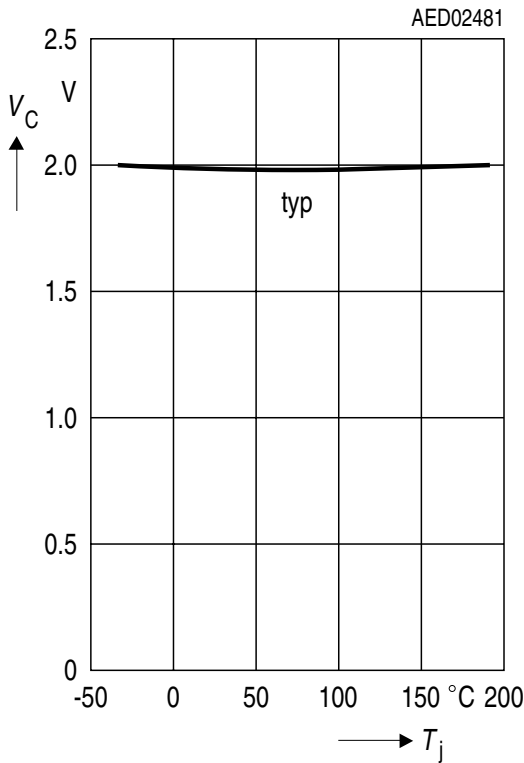

Filter Input Resistance versus Temperature

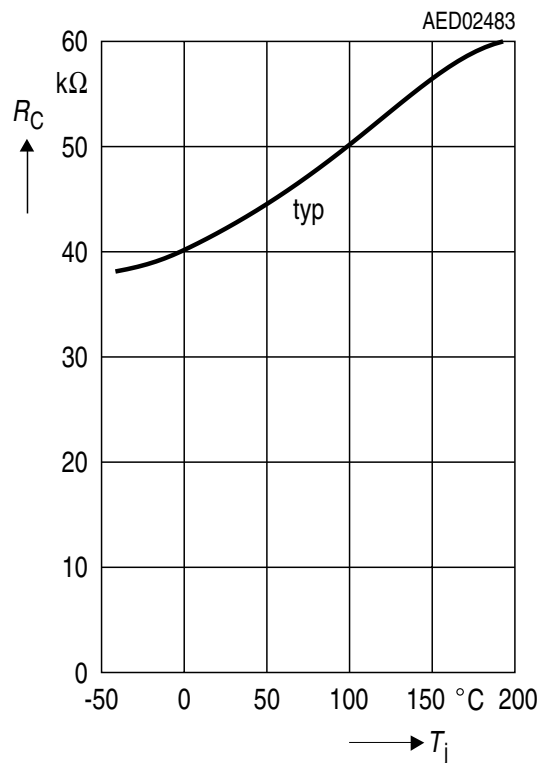

Filter Sensitivity versus Temperature

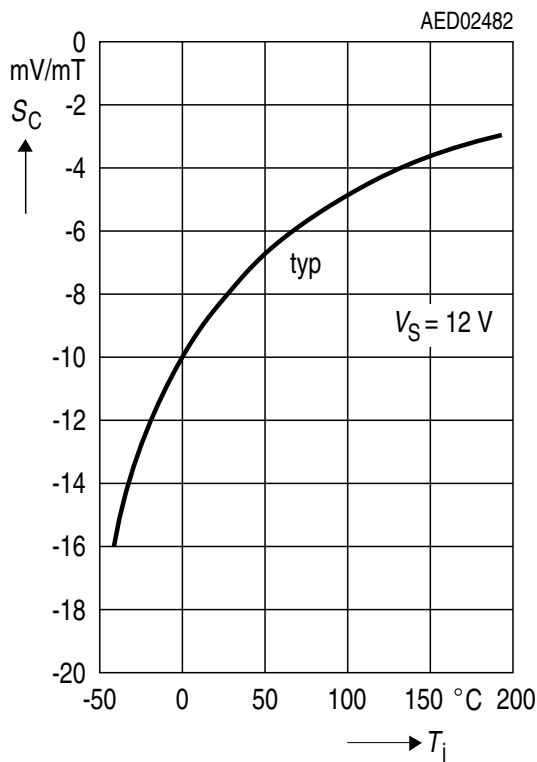

Delay Time t_{pon} for Power ON versus Temperature

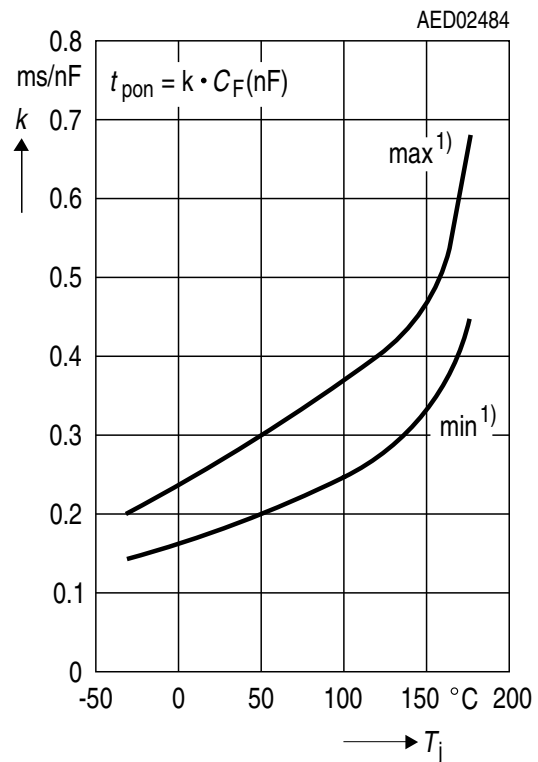

1) Calculated values for minimum and maximum filter resistance, C_F at room temperature.

Typical Performance Characteristics

Threshold Shift versus Filter Leakage

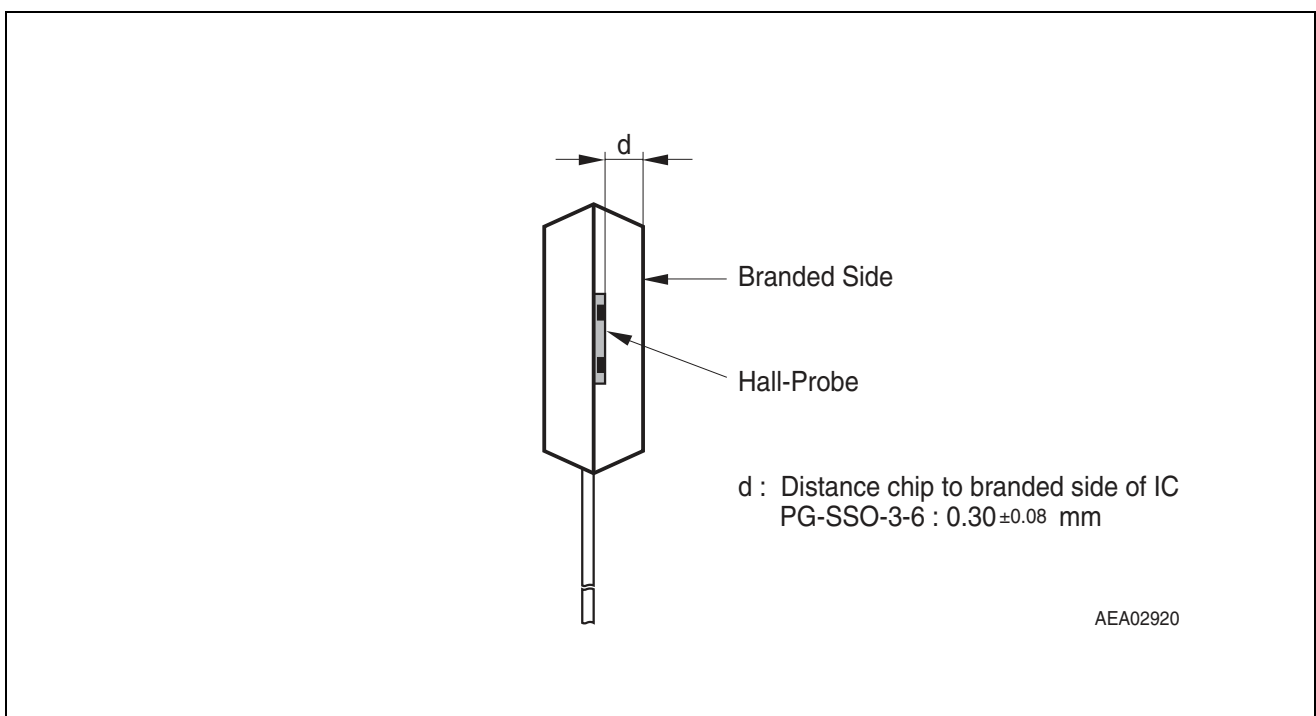
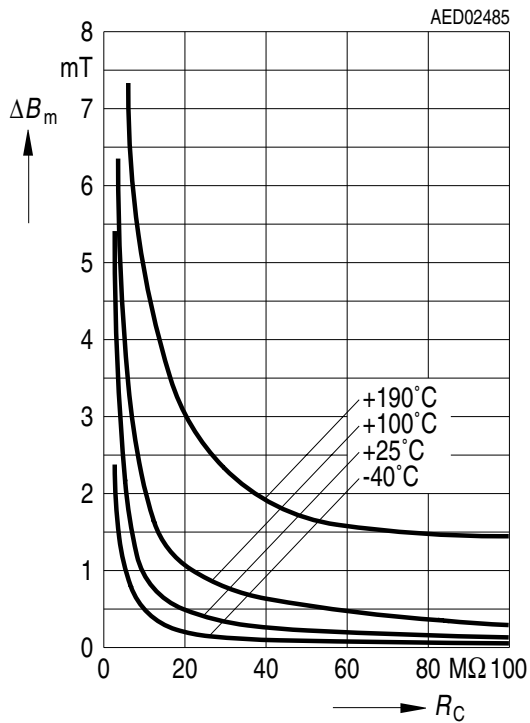

Figure 14 Distance Chip to Upper Side of IC

8 Package Outlines

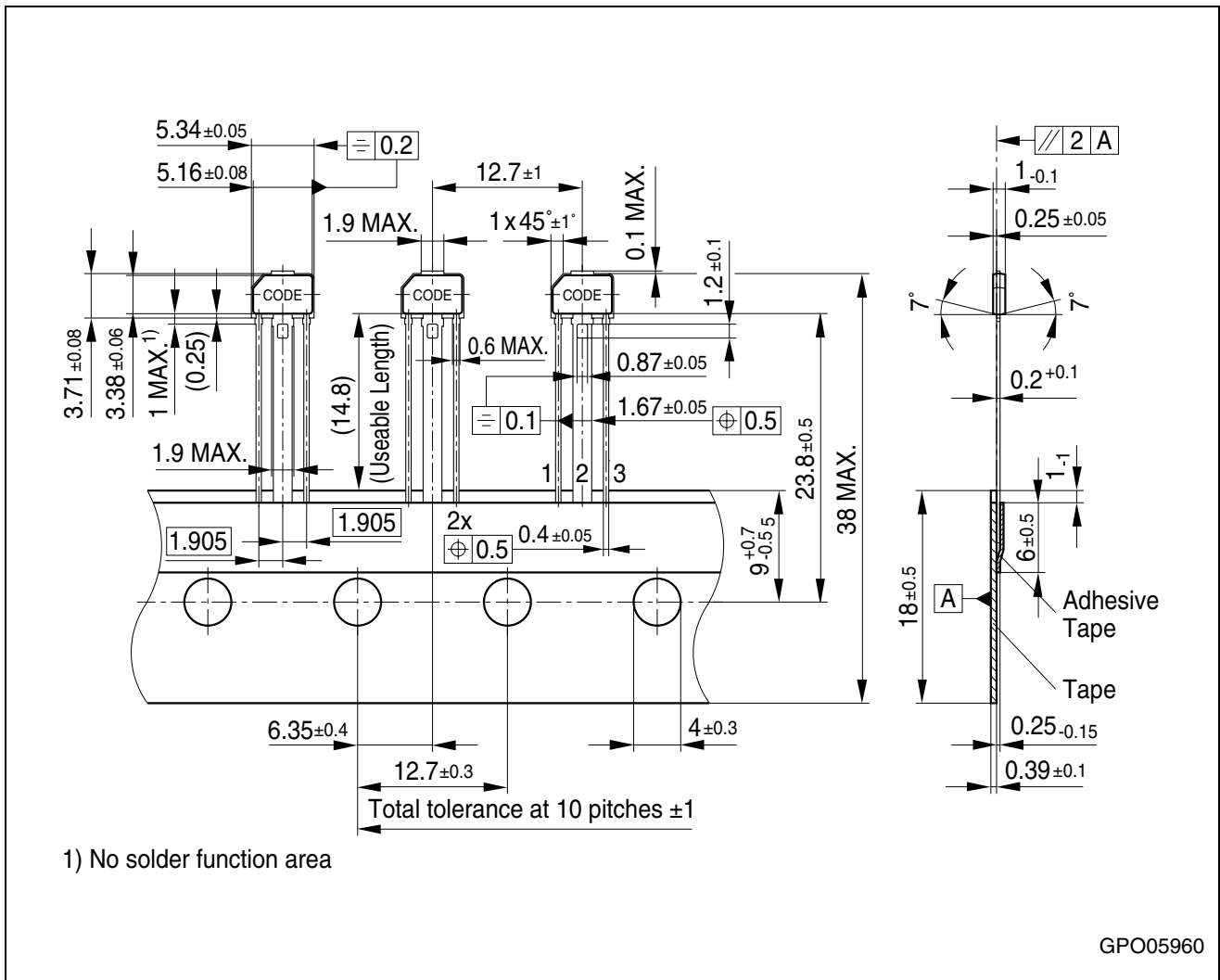

Figure 15 PG-SSO-3-6 (Plastic Single Small Outline Package)

You can find all of our packages, sorts of packing and others in our Infineon Internet Page "Products": <http://www.infineon.com/products>.

Dimensions in mm

www.infineon.com

Published by Infineon Technologies AG