

TMR265x

High Frequency Response Programmable TMR Linear Magnetic Sensor

Description

The TMR265x is a tunneling magnetoresistance (TMR) linear sensor with a dedicated signal conditioning circuit built in. The integrated signal conditioning circuit of TMR265x is able to calibrate zero offset, gain, temperature coefficient of sensitivity (TCS) and temperature coefficient of zero offset (TCO) of the TMR bridge circuit, and outputs the conditioned voltage signals.

In addition to TMR's intrinsic advantages of high resolution, high signal-to-noise ratio, and low power consumption, TMR265x series linear sensors also provide the following characteristics:

1. Fixed voltage output range in linear range
2. Excellent sensitivity consistency
3. Minimal zero drift
4. Low temperature coefficient of sensitivity
5. Low temperature coefficient of offset

This improvement greatly enhances the convenience of design and use of TMR linear sensor products.

The TMR265x linear magnetic sensor is available in DFN6L (3 mm × 2 mm × 0.75mm) package with P/N of TMR2651D and TMR2652D.



DFN6L

Features and Benefits

- Tunneling magnetoresistance (TMR) technology
- High frequency response: DC to 2 MHz
- Large dynamic range: TMR2651D: ± 1000 Gs
TMR2652D: ± 500 Gs
- Wide range supply voltages: 3 V to 5.5 V
- Nonlinearity: 0.2%
- Programmable sensitivity and zero offset
- Programmable temperature compensation
- RoHS & REACH compliant

Applications

- Current sensor
- Linear position sensor
- Gaussmeter
- Encoder

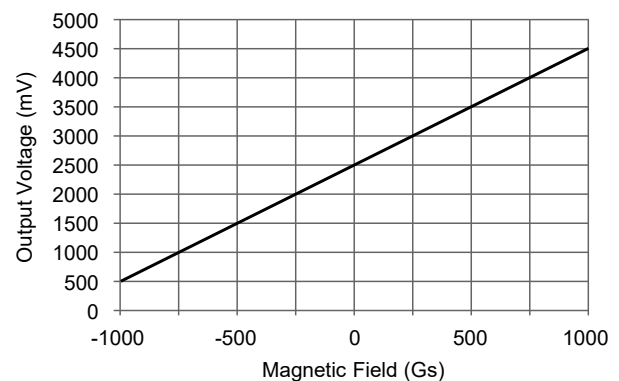

TMR2651D ± 1000 Gs Output Curve

Selection Guide

Part Number	Supply Voltage	Linear Range	Non-Linearity	Package	Packing Form
TMR2651D	3 V to 5.5 V	±1000 Gs	0.2 %	DFN6L	Tape & Reel
TMR2652D	3 V to 5.5 V	±500 Gs	0.2 %	DFN6L	Tape & Reel

Catalogue

1. Functional Block Diagram.....	03
2. Pin Configuration	03
3. Sensing Direction	03
4. Absolute Maximum Ratings	04
5. Electrical Specifications.....	04
6. Typical Bandwidth Characteristics.....	05
7. Application Information	06
8. Dimensions.....	07

1. Functional Block Diagram

TMR265x integrates a linear TMR magnetic sensor and a dedicated signal conditioning chip with a single-ended analog voltage output signal. The V_{OUT} pin can be reused as the OWI (one-wire-interface) protocol programming interface, to adjust zero-point, sensitivity, reference voltage V_{REF} and other parameters in a targeted manner.

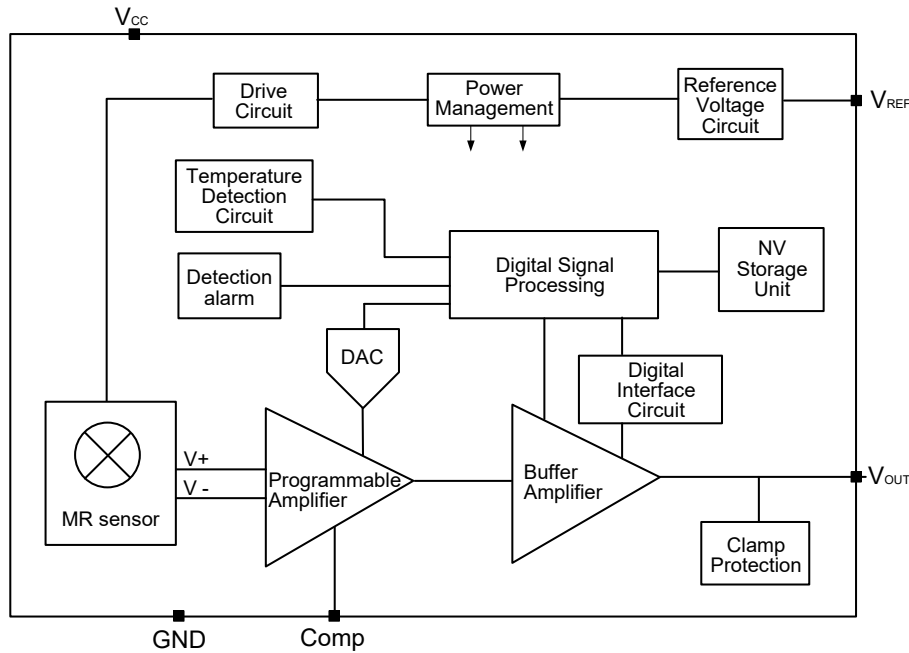

Figure 1. Block diagram of TMR265x

2. Pin Configuration

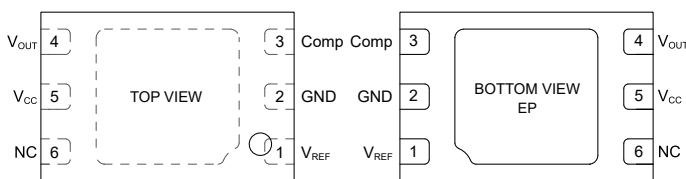

Figure 2. Pin configuration (DFN6L)

Number	Name	Function
1	V_{REF}	Reference voltage output
2	GND	Ground
3	Comp	Analog voltage
4	V_{OUT}	Analog output / OWI communication interface
5	V_{CC}	Power supply
6	NC	Not connected
	EP	Heat dissipation

3. Sensing Direction

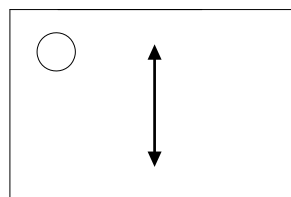

Figure 3. Sensing direction

4. Absolute Maximum Ratings

Parameters	Symbol	Min.	Max.	Unit
Supply voltage	V_{CC}	3	5.5	V
Supply current	$I_{CC}^{1)}$	-	8	mA
External magnetic field	B	-	4000	Gs
ESD performance (HBM)	V_{ESD}	-	4	kV
Operating ambient temperature	T_A	-40	125	°C
Storage ambient temperature	T_{STG}	-50	150	°C

1) Supply current I_{CC} refers to the current to operate after calibration.

5. Electrical Specifications

Parameter	Symbol	Condition	Min.	Typ.	Max.	Unit	Applicable Part Number
Supply voltage	V_{CC}	$T_A = 25\text{ °C}$	3	3.3/5	5.5	V	All parts
Supply current	I_{CC}	$V_{CC} = 5\text{ V}, T_A = 25\text{ °C}$	-	5	8	mA	All parts
Power-on time	t_{PO}	$T_A = 25\text{ °C}$	-	100	-	μs	All parts
Linear range	B_{LIN}	-	-1000	-	1000	Gs	TMR2651D
		-	-500	-	500	Gs	TMR2652D
Sensitivity	$SEN^{2)}$	$V_{CC} = 5\text{ V}, T_A = 25\text{ °C}$	1 to 100 programmable			mV/Gs	All parts
		$V_{CC} = 3.3\text{ V}, T_A = 25\text{ °C}$					All parts
Zero offset	V_{OFFSET}	$V_{CC} = 5\text{ V}, T_A = 25\text{ °C}$	-	2.5	-	V	All parts
		$V_{CC} = 3.3\text{ V}, T_A = 25\text{ °C}$	-	1.65	-	V	All parts
Reference voltage	V_{REF}	$V_{CC} = 5\text{ V}, T_A = 25\text{ °C}$	-	2.5	-	V	All parts
		$V_{CC} = 3.3\text{ V}, T_A = 25\text{ °C}$	-	1.65	-	V	All parts
Hysteresis	HYS	$T_A = 25\text{ °C}, \pm 200\text{ Gs}$	-	0.2	-	Gs	All parts
		$T_A = 25\text{ °C}, \pm 500\text{ Gs}$	-	0.5	-	Gs	All parts
		$T_A = 25\text{ °C}, \pm 1000\text{ Gs}$	-	1	-	Gs	All parts
		$T_A = 25\text{ °C}, \pm 1500\text{ Gs}$	-	1.5	-	Gs	All parts
Nonlinearity	NONL	$T_A = 25\text{ °C}$	-	0.2	-	%FS	All parts
Temperature coefficient of sensitivity	TCS ³⁾	-40 °C to 125 °C	-	50	-	PPM/°C	All parts
Noise	Noise	$T_A = 25\text{ °C}, 1\text{ Hz}$	-	150	-	nT/rt(Hz)	All parts
			-	20	-	μV/rt(Hz)	All parts
Temperature coefficient of offset	TCO ⁴⁾	-40 °C to 125 °C	-	0.1	-	mV/°C	All parts
Response frequency	F	varies with gain	DC to 2 MHz				All parts

2) The typical value of sensitivity is programmable via OWI protocol.

3) The sensor can be programmed to perform multi-point temperature measurement to calibrate TCS for better performance.

4) The sensor can be programmed to perform multi-point temperature measurement to calibrate TCO for better performance.

6. Typical Bandwidth Characteristics

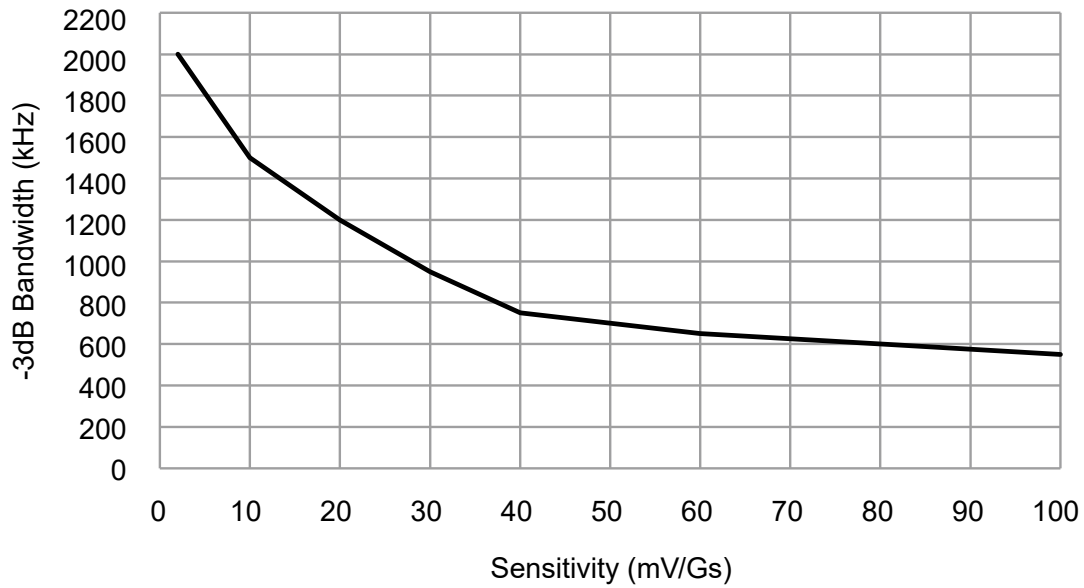
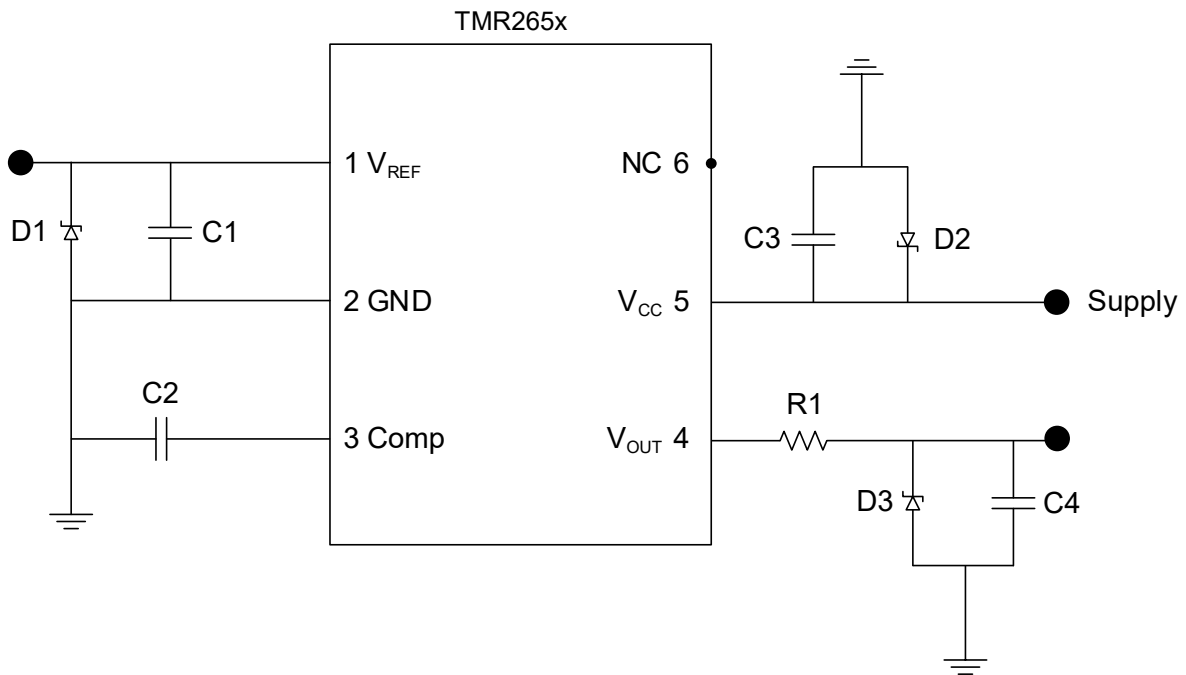

Figure 4. Bandwidth versus sensitivity

7. Application Information



Note:

R1	-	R1/C4: for output pin RC filtering
C1	20 pF	Connects V_{REF} to GND for reference voltage filtering
C2	20 pF	Connects Comp to V_{OUT} for output voltage filtering
C3	0.1 μ F	Connects V_{CC} to GND for supply voltage filtering
C4	-	R1/C4: for output pin RC filtering
D1	ESD5341N_5V/NA	Dual lead bidirectional 5V transient voltage suppression devices for ESD/surge protection.
D2	ESD5341N_5V/NA	Dual lead bidirectional 5V transient voltage suppression devices for ESD/surge protection.
D3	ESD5341N_5V/NA	Dual lead bidirectional 5V transient voltage suppression devices for ESD/surge protection.

Figure 5. Typical application circuit

Please refer to the TMR265x product application manual for more product applications and OWI programming instructions.

8. Dimensions
DFN6L Package

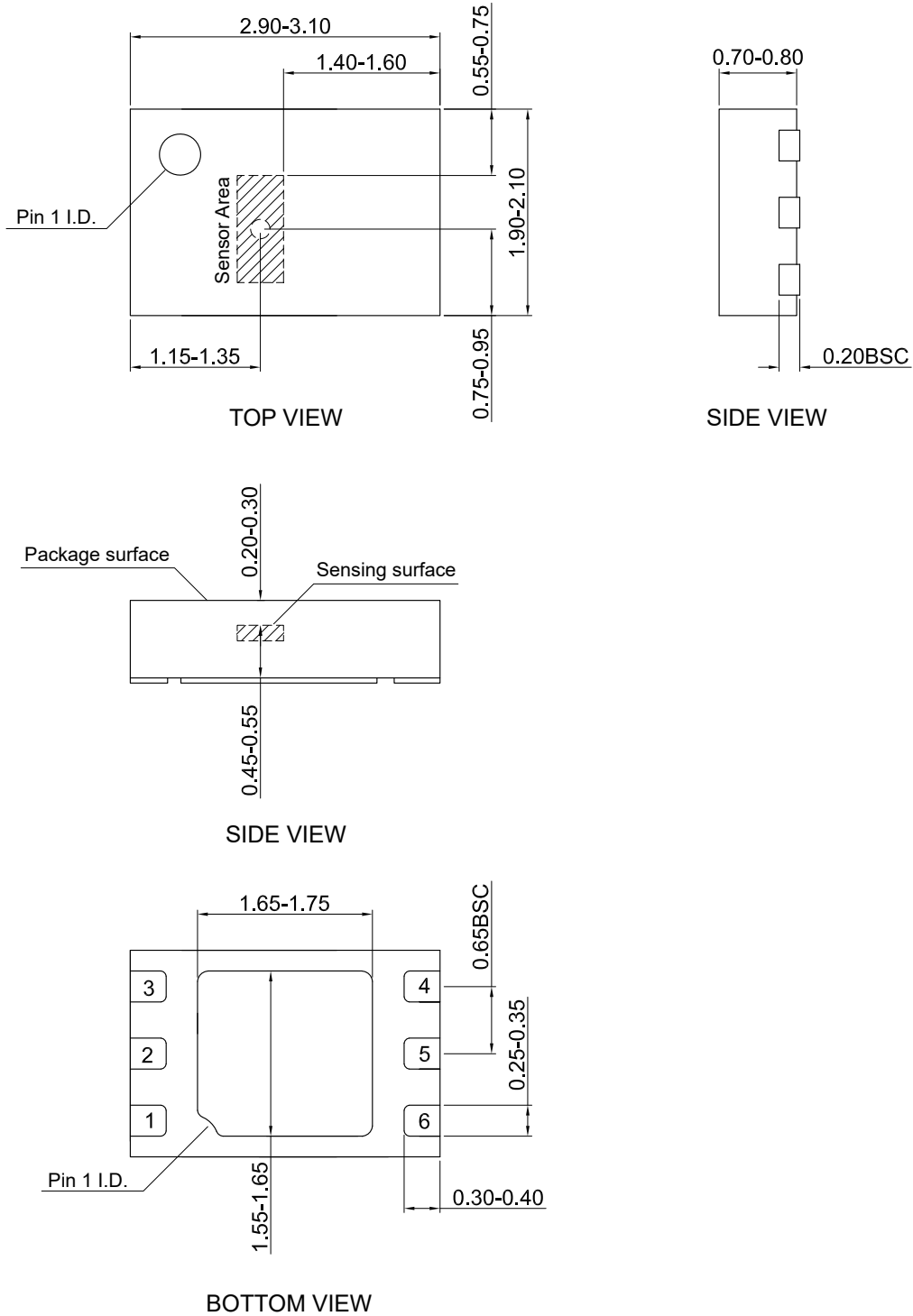

Figure 6. Package outline of DFN6L (unit: mm)

Copyright © 2023 by MultiDimension Technology Co., Ltd.

Information furnished herein by MultiDimension Technology Co., Ltd. (hereinafter MDT) is believed to be accurate and reliable. However, MDT disclaims any and all warranties and liabilities of any kind, with respect to any examples, hints or any performance or use of technical data as described herein and/or any information regarding the application of the product, including without limitation warranties of non-infringement of intellectual property rights of any third party. This document neither conveys nor implies any license under patent or other industrial or intellectual property rights. Customer or any third-party must further determine the suitability of the MDT products for its applications to avoid the applications default of customer or third-party. MDT accept no liability in this respect.

MDT does not assume any liabilities of any indirect, incidental, punitive, special or consequential damages (including without limitation of lost profits, lost savings, business interruption, costs related to the removal or replacement of any products or rework charges) whether or not such damages are based on tort (including negligence), warranty, breach of contract or any other legal theory. Notwithstanding any damages that customer might incur for any reason whatsoever, MDT's aggregate and cumulative liability towards customer for the products described herein shall be limited in accordance with the terms and conditions of commercial sale of MDT.

Absolute maximum ratings are the extreme limits the device will withstand without damage to the MDT product. However, the electrical and mechanical characteristics are not guaranteed as the maximum limits (above recommended operating conditions) are approached. MDT disclaims any and all warranties and liabilities of the MDT product will operate at absolute maximum ratings.

Specifications may change without notice.

Please download latest document from our official website www.dowaytech.com/en.

Recycling

The product(s) in this document need to be handed over to a qualified solid waste management services company for recycling in accordance with relevant regulations on waste classification after the end of the product(s) life.



No.2 Guangdong Road, Zhangjiagang Free Trade Zone, Jiangsu, China

Web: www.dowaytech.com/en E-mail: info@dowaytech.com

