

# ON Semiconductor

## Is Now

# onsemi™

To learn more about onsemi™, please visit our website at  
[www.onsemi.com](http://www.onsemi.com)

---

**onsemi** and **onsemi** and other names, marks, and brands are registered and/or common law trademarks of Semiconductor Components Industries, LLC dba "**onsemi**" or its affiliates and/or subsidiaries in the United States and/or other countries. **onsemi** owns the rights to a number of patents, trademarks, copyrights, trade secrets, and other intellectual property. A listing of **onsemi** product/patent coverage may be accessed at [www.onsemi.com/site/pdf/Patent-Marking.pdf](http://www.onsemi.com/site/pdf/Patent-Marking.pdf). **onsemi** reserves the right to make changes at any time to any products or information herein, without notice. The information herein is provided "as-is" and **onsemi** makes no warranty, representation or guarantee regarding the accuracy of the information, product features, availability, functionality, or suitability of its products for any particular purpose, nor does **onsemi** assume any liability arising out of the application or use of any product or circuit, and specifically disclaims any and all liability, including without limitation special, consequential or incidental damages. Buyer is responsible for its products and applications using **onsemi** products, including compliance with all laws, regulations and safety requirements or standards, regardless of any support or applications information provided by **onsemi**. "Typical" parameters which may be provided in **onsemi** data sheets and/or specifications can and do vary in different applications and actual performance may vary over time. All operating parameters, including "Typicals" must be validated for each customer application by customer's technical experts. **onsemi** does not convey any license under any of its intellectual property rights nor the rights of others. **onsemi** products are not designed, intended, or authorized for use as a critical component in life support systems or any FDA Class 3 medical devices or medical devices with a same or similar classification in a foreign jurisdiction or any devices intended for implantation in the human body. Should Buyer purchase or use **onsemi** products for any such unintended or unauthorized application, Buyer shall indemnify and hold **onsemi** and its officers, employees, subsidiaries, affiliates, and distributors harmless against all claims, costs, damages, and expenses, and reasonable attorney fees arising out of, directly or indirectly, any claim of personal injury or death associated with such unintended or unauthorized use, even if such claim alleges that **onsemi** was negligent regarding the design or manufacture of the part. **onsemi** is an Equal Opportunity/Affirmative Action Employer. This literature is subject to all applicable copyright laws and is not for resale in any manner. Other names and brands may be claimed as the property of others.

# MC34160, MC33160

## 100 mA, 5.0 V Voltage Regulator and Supervisory Circuit for Microprocessors

The MC34160 Series is a voltage regulator and supervisory circuit containing many of the necessary monitoring functions required in microprocessor based systems. It is specifically designed for appliance and industrial applications, offering the designer a cost effective solution with minimal external components. These integrated circuits feature a 5.0 V/100 mA regulator with short circuit current limiting, pinned out 2.6 V bandgap reference, low voltage reset comparator, power warning comparator with programmable hysteresis, and an uncommitted comparator ideally suited for microprocessor line synchronization.

Additional features include a chip disable input for low standby current, and internal thermal shutdown for over temperature protection.

These devices are contained in a 16 pin dual-in-line heat tab plastic package for improved thermal conduction.

### Features

- 5.0 V Regulator Output Current in Excess of 100 mA
- Internal Short Circuit Current Limiting
- Pinned Out 2.6 V Reference
- Low Voltage Reset Comparator
- Power Warning Comparator with Programmable Hysteresis
- Uncommitted Comparator
- Low Standby Current
- Internal Thermal Shutdown Protection
- Heat Tab Power Package
- Pb-Free Packages are Available\*

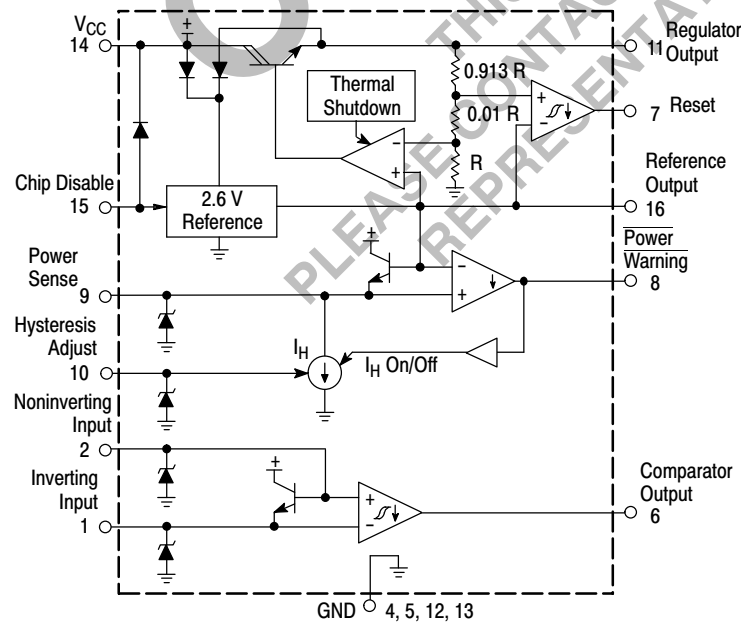

This device contains 72 active transistors.

**Figure 1. Representative Block Diagram**



**ON Semiconductor®**

<http://onsemi.com>

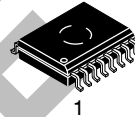

**SOIC-16WB  
DW SUFFIX  
CASE 751G**

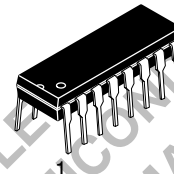

**PDIP-16  
P SUFFIX  
CASE 648C**

### PIN CONNECTIONS

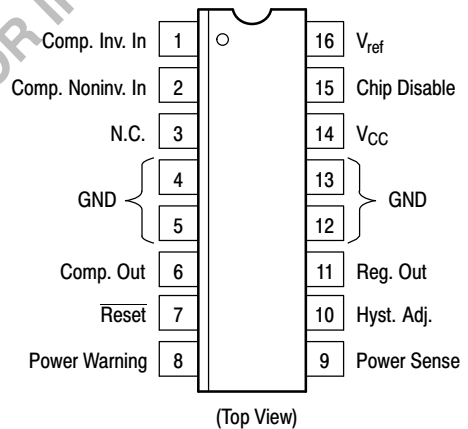

### ORDERING INFORMATION

See detailed ordering and shipping information in the package dimensions section on page 9 of this data sheet.

### DEVICE MARKING INFORMATION

See general marking information in the device marking section on page 9 of this data sheet.

\*For additional information on our Pb-Free strategy and soldering details, please download the ON Semiconductor Soldering and Mounting Techniques Reference Manual, SOLDERRM/D.

# MC34160, MC33160

## MAXIMUM RATINGS

Rating	Symbol	Value	Unit
Power Supply Voltage	$V_{CC}$	40	V
Chip Disable Input Voltage (Pin 15, Note 1)	$V_{CD}$	-0.3 to $V_{CC}$	V
Comparator Input Current (Pins 1, 2, 9)	$I_{in}$	-2.0 to +2.0	mA
Comparator Output Voltage (Pins 6, 7, 8)	$V_O$	40	V
Comparator Output Sink Current (Pins 6, 7, 8)	$I_{Sink}$	10	mA
Power Dissipation and Thermal Characteristics P Suffix, Dual-In-Line Case 648C Thermal Resistance, Junction-to-Air Thermal Resistance, Junction-to-Case (Pins 4, 5, 12, 13) DW Suffix, Surface Mount Case 751G Thermal Resistance, Junction-to-Air Thermal Resistance, Junction-to-Case (Pins 4, 5, 12, 13)	$R_{\theta JA}$ $R_{\theta JC}$ $R_{\theta JA}$ $R_{\theta JC}$	80 15 94 18	°C/W
Operating Junction Temperature	$T_J$	+150	°C
Operating Ambient Temperature	$T_A$	0 to +70 -40 to +85	°C
Storage Temperature Range	$T_{stg}$	-65 to +150	°C

Stresses exceeding Maximum Ratings may damage the device. Maximum Ratings are stress ratings only. Functional operation above the Recommended Operating Conditions is not implied. Extended exposure to stresses above the Recommended Operating Conditions may affect device reliability.

1. The maximum voltage range is -0.3 V to  $V_{CC}$  or +35 V, whichever is less.

**ELECTRICAL CHARACTERISTICS** ( $V_{CC} = 30$  V,  $I_O = 10$  mA,  $I_{ref} = 100$   $\mu$ A) For typical values  $T_A = 25^\circ$ C, for min/max values  $T_A$  is the operating ambient temperature range that applies [Notes 2 and 3], unless otherwise noted.)

Characteristics	Symbol	Min	Typ	Max	Unit
-----------------	--------	-----	-----	-----	------

### REGULATOR SECTION

Total Output Variation ( $V_{CC} = 7.0$ V to 40 V, $I_O = 1.0$ mA to 100 mA, $T_A = T_{low}$ to $T_{high}$ )	$V_O$	4.75	5.0	5.25	V
Line Regulation ( $V_{CC} = 7.0$ V to 40 V, $T_A = 25^\circ$ C)	$Reg_{line}$	-	5.0	40	mV
Load Regulation ( $I_O = 1.0$ mA to 100 mA, $T_A = 25^\circ$ C)	$Reg_{load}$	-	20	50	mV
Ripple Rejection ( $V_{CC} = 25$ V to 35 V, $I_O = 40$ mA, $f = 120$ Hz, $T_A = 25^\circ$ C)	RR	50	65	-	dB

### REFERENCE SECTION

Total Output Variation ( $V_{CC} = 7.0$ to 40 V, $I_O = 0.1$ mA to 2.0 mA, $T_A = T_{low}$ to $T_{high}$ )	$V_{ref}$	2.47	2.6	2.73	V
Line Regulation ( $V_{CC} = 5.0$ V to 40 V, $T_A = 25^\circ$ C)	$Reg_{line}$	-	2.0	20	mV
Load Regulation ( $I_O = 0.1$ mA to 2.0 mA, $T_A = 25^\circ$ C)	$Reg_{load}$	-	4.0	30	mV

### RESET COMPARATOR

Threshold Voltage	High State Output (Pin 11 Increasing) Low State Output (Pin 11 Decreasing) Hysteresis	$V_{IH}$ $V_{IL}$ $V_H$	- 4.55 0.02	$(V_O - 0.11)$ $(V_O - 0.18)$ 0.07	$(V_O - 0.05)$ - -	V
Output Sink Saturation ( $V_{CC} = 4.5$ V, $I_{Sink} = 2.0$ mA)		$V_{OL}$	-	-	0.4	V
Output Off-State Leakage ( $V_{OH} = 40$ V)		$I_{OH}$	-	-	4.0	$\mu$ A

### POWER WARNING COMPARATOR

Input Offset Voltage		$V_{IO}$	-	1.2	10	mV
Input Bias Current ( $V_{Pin 9} = 3.0$ V)		$I_{IB}$	-	-	0.5	$\mu$ A
Input Hysteresis Current ( $V_{Pin 9} = V_{ref} - 100$ mV)	$R_{Pin 10} = 24$ k $R_{Pin 10} = \infty$	$I_H$	40 4.5	50 7.5	60 11	$\mu$ A
Output Sink Saturation ( $I_{Sink} = 2.0$ mA)		$V_{OL}$	-	0.13	0.4	V
Output Off-State Leakage ( $V_{OH} = 40$ V)		$I_{OH}$	-	-	4.0	$\mu$ A

2.  $T_{lo} = 0^\circ$ C for MC34160  $T_{high} = 70^\circ$ C for MC34160  
-40°C for MC33160 85°C for MC33160

3. Low duty cycle pulse testing techniques are used during test to maintain junction temperature as close to ambient as possible.

## MC34160, MC33160

**ELECTRICAL CHARACTERISTICS** (continued) ( $V_{CC} = 30\text{ V}$ ,  $I_O = 10\text{ mA}$ ,  $I_{ref} = 100\text{ }\mu\text{A}$ ) For typical values  $T_A = 25^\circ\text{C}$ , for min/max values  $T_A$  is the operating ambient temperature range that applies [Notes 4 and 5], unless otherwise noted.)

Characteristics		Symbol	Min	Typ	Max	Unit
<b>UNCOMMITTED COMPARATOR</b>						
Input Offset Voltage (Output Transition Low to High)		$V_{IO}$	–	–	20	mV
Input Hysteresis Voltage (Output Transition High to Low)		$I_H$	140	200	260	mV
Input Bias Current ( $V_{Pin\ 1, 2} = 2.6\text{ V}$ )		$I_B$	–	–	–1.0	$\mu\text{A}$
Input Common Mode Voltage Range		$V_{ICR}$	0.6 to 5.0	–	–	V
Output Sink Saturation ( $I_{Sink} = 2.0\text{ mA}$ )		$V_{OL}$	–	0.13	0.4	V
Output Off-State Leakage ( $V_{OH} = 40\text{ V}$ )		$I_{OH}$	–	–	4.0	$\mu\text{A}$
<b>TOTAL DEVICE</b>						
Chip Disable Threshold Voltage (Pin 15)	High State (Chip Disabled)	$V_{IH}$	2.5	–	–	V
	Low State (Chip Enabled)	$V_{IL}$	–	–	0.8	V
Chip Disable Input Current (Pin 15)	High State ( $V_{in} = 2.5\text{ V}$ )	$I_{IH}$	–	–	100	$\mu\text{A}$
	Low State ( $V_{in} = 0.8\text{ V}$ )	$I_{IL}$	–	–	30	$\mu\text{A}$
Chip Disable Input Resistance (Pin 15)		$R_{in}$	50	100	–	$\text{k}\Omega$
Operating Voltage Range	$V_O$ (Pin 11) Regulated	$V_{CC}$	7.0 to 40	–	–	V
	$V_{ref}$ (Pin 16) Regulated		5.0 to 40	–	–	V
Power Supply Current	Standby (Chip Disable High State)	$I_{CC}$	–	0.18	0.35	mA
	Operating (Chip Disable Low State)		–	1.5	3.0	mA

4.  $T_{lo} = 0^\circ\text{C}$  for MC34160     $T_{high} = 70^\circ\text{C}$  for MC34160  
       $-40^\circ\text{C}$  for MC33160         $85^\circ\text{C}$  for MC33160

5. Low duty cycle pulse testing techniques are used during test to maintain junction temperature as close to ambient as possible.

MC34160, MC33160

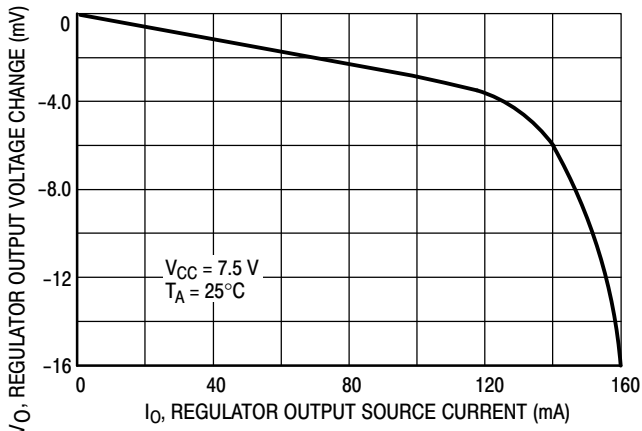

Figure 2. Regulator Output Voltage Change versus Source Current

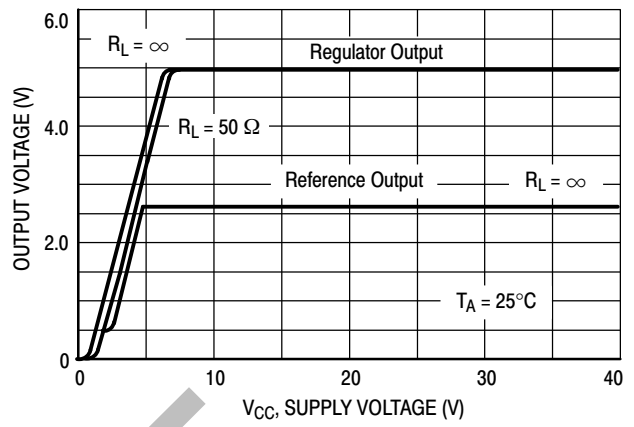

Figure 3. Reference and Regulator Output versus Supply Voltage

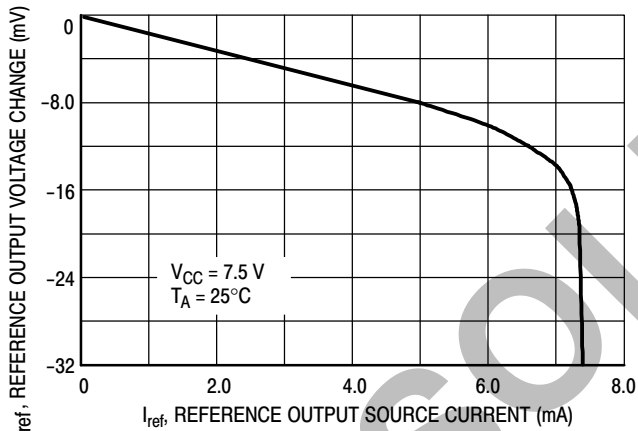

Figure 4. Reference Output Voltage Change versus Source Current

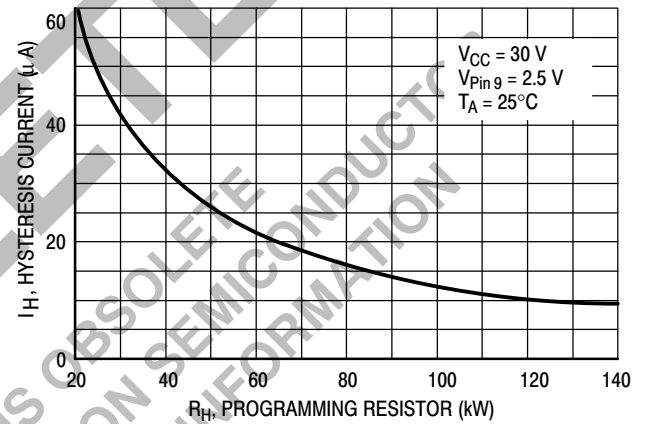
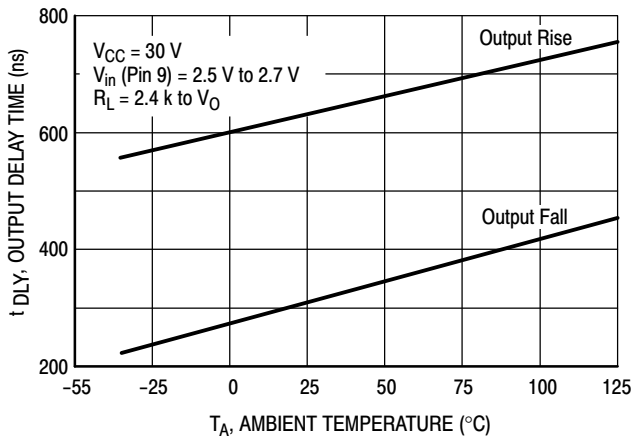

Figure 5. Power Warning Hysteresis Current versus Programming Resistor

OBSOLETE

THIS DEVICE IS OBSOLETE  
PLEASE CONTACT YOUR ON SEMICONDUCTOR  
REPRESENTATIVE FOR MORE INFORMATION

# MC34160, MC33160



**Figure 6. Power Warning Comparator Delay versus Temperature**

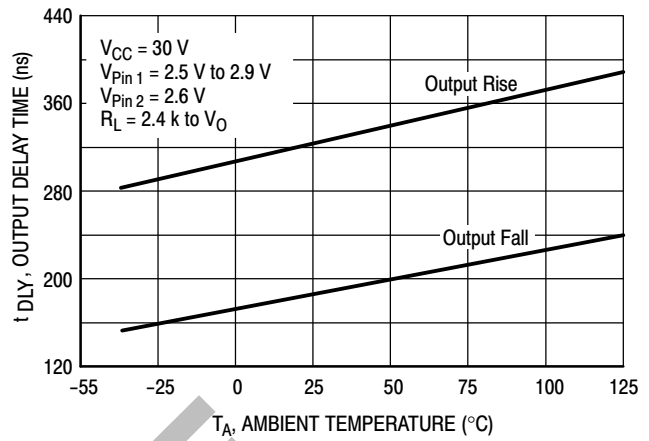

**Figure 7. Uncommitted Comparator Delay versus Temperature**

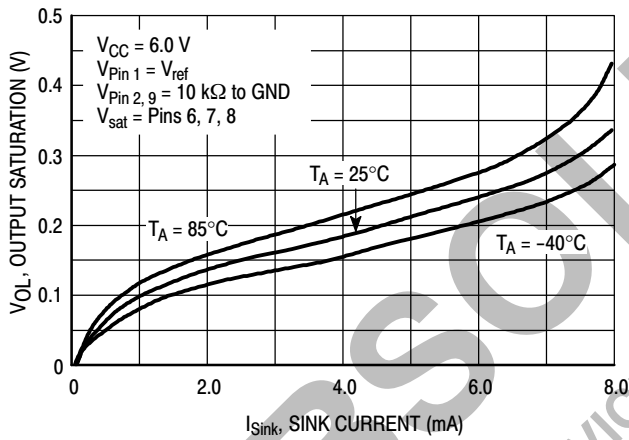

**Figure 8. Comparator Output Saturation versus Sink Current**

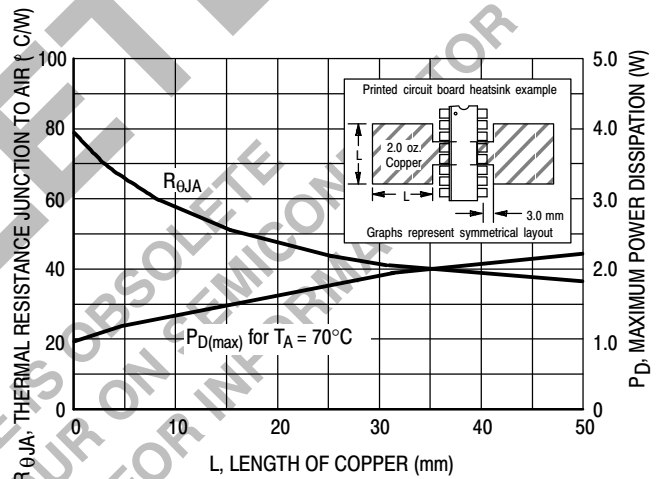

**Figure 9. P Suffix (DIP-16) Thermal Resistance and Maximum Power Dissipation versus P.C.B. Copper Length**

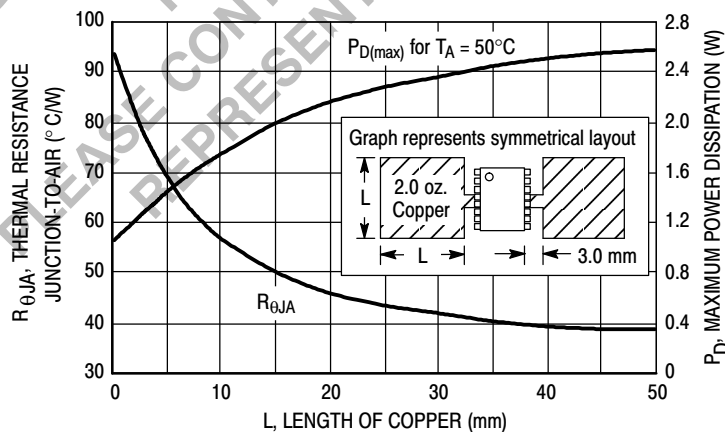

**Figure 10. DW Suffix (SOP-16L) Thermal Resistance and Maximum Power Dissipation versus P.C.B. Copper Length**

## MC34160, MC33160

### PIN FUNCTION DESCRIPTION

Pin	Function	Description
1	Comparator Inverting Input	This is the Uncommitted Comparator Inverting input. It is typically connected to a resistor divider to monitor a voltage.
2	Comparator Noninverting Input	This is the Uncommitted Comparator Noninverting input. It is typically connected to a reference voltage.
3	N.C.	No connection. This pin is not internally connected.
4, 5, 12, 13	GND	These pins are the control circuit grounds and are connected to the source and load ground returns. They are part of the IC lead frame and can be used for heatsinking.
6	Comparator Output	This is the Uncommitted Comparator output. It is an open collector sink-only output requiring a pullup resistor.
7	Reset	This is the Reset Comparator output. It is an open collector sink-only output requiring a pullup resistor.
8	Power Warning	This is the Power Warning Comparator output. It is an open collector sink-only output requiring a pullup resistor.
9	Power Sense	This is the Power Warning Comparator noninverting input. It is typically connected to a resistor divider to monitor the input power source voltage.
10	Hysteresis Adjust	The Power Warning Comparator hysteresis is programmed by a resistor connected from this pin to ground.
11	Regulator Output	This is the 5.0 V Regulator output.
14	V <sub>CC</sub>	This pin is the positive supply input of the control IC.
15	Chip Disable	This input is used to switch the IC into a standby mode turning off all outputs.
16	V <sub>ref</sub>	This is the 2.6 V Reference output. It is intended to be used in conjunction with the Power Warning and Uncommitted comparators.

### OPERATING DESCRIPTION

The MC34160 series is a monolithic voltage regulator and supervisory circuit containing many of the necessary monitoring functions required in microprocessor based systems. It is specifically designed for appliance and industrial applications, offering the designer a cost effective solution with minimal external components. These devices are specified for operation over an input voltage of 7.0 V to 40 V, and with a junction temperature of  $-40^{\circ}$  to  $+150^{\circ}$ C. A typical microprocessor application is shown in Figure 11.

#### Regulator

The 5.0 V regulator is designed to source in excess of 100 mA output current and is short circuit protected. The output has a guaranteed tolerance of  $\pm 5.0\%$  over line, load, and temperature. Internal thermal shutdown circuitry is included to limit the maximum junction temperature to a safe level. When activated, typically at  $170^{\circ}$ C, the regulator output turns off.

In specific situations a combination of input and output bypass capacitors may be required for regulator stability. If the regulator is located an appreciable distance ( $\geq 4''$ ) from the supply filter, an input bypass capacitor ( $C_{in}$ ) of  $0.33 \mu\text{F}$  or greater is suggested. Output capacitance values of less than  $5.0 \text{ nF}$  may cause regulator instability at light load ( $\leq 1.0 \text{ mA}$ ) and cold temperature. An output bypass

capacitor of  $0.1 \mu\text{F}$  or greater is recommended to ensure stability under all load conditions. The capacitors selected must provide good high frequency characteristics.

Good construction techniques should be used to minimize ground loops and lead resistance drops since the regulator does not have external sense inputs.

#### Reference

The 2.6 V bandgap reference is short circuit protected and has a guaranteed output tolerance of  $\pm 5.0\%$  over line, load, and temperature. It is intended to be used in conjunction with the Power Warning and Uncommitted comparator. The reference can source in excess of  $2.0 \text{ mA}$  and sink a maximum of  $10 \mu\text{A}$ . For additional current sinking capability, an external load resistor to ground must be used.

Reference biasing is internally derived from either V<sub>CC</sub> or V<sub>O</sub>, allowing proper operation if either drops below nominal.

#### Chip Disable

This input is used to switch the IC into a standby mode. When activated, internal biasing for the entire die is removed causing all outputs to turn off. This reduces the power supply current (I<sub>CC</sub>) to less than  $0.3 \text{ mA}$ .

**Comparators**

Three separate comparators are incorporated for voltage monitoring. Their outputs can provide diagnostic information to the microprocessor, preventing system malfunctions.

The Reset Comparator Inverting Input is internally connected to the 2.6 V reference while the Noninverting Input monitors  $V_O$ . The Reset Output is active low when  $V_O$  falls approximately 180 mV below its regulated voltage. To prevent erratic operation when crossing the comparator threshold, 70 mV of hysteresis is provided.

The Power Warning Comparator is typically used to detect an impending loss of system power. The Inverting Input is internally connected to the reference, fixing the threshold at 2.6 V. The input power source  $V_{in}$  is monitored by the Noninverting Input through the  $R_1/R_2$  divider (Figure 11). This input features an adjustable 10  $\mu$ A to 50  $\mu$ A current sink  $I_H$  that is programmed by the value selected for resistor  $R_H$ . A default current of 6.5  $\mu$ A is provided if  $R_H$  is omitted. When the comparator input falls below 2.6 V, the current sink is activated. This produces hysteresis if  $V_{in}$  is monitored through a series resistor ( $R_1$ ). The comparator thresholds are defined as follows:

$$V_{th(lower)} = V_{ref} \left( 1 + \frac{R_1}{R_2} \right) - I_{IB} R_1$$

$$V_{th(upper)} = V_{ref} \left( 1 + \frac{R_1}{R_2} \right) + I_H R_1$$

The nominal hysteresis current  $I_H$  equals 1.2 V/ $R_H$  (Figure 5).

The Uncommitted Comparator can be used to synchronize the microprocessor with the ac line signal for timing functions, or for synchronous load switching. It can also be connected as a line loss detector as shown in Figure 12. The comparator contains 200 mV of hysteresis preventing erratic output behavior when crossing the input threshold.

The Power Warning and Uncommitted Comparators each have a transistor base-emitter connected across their inputs. The base input normally connects to a voltage reference while the emitter input connects to the voltage to be monitored. The transistor limits the negative excursion on the emitter input to - 0.7 V below the base input by supply current from  $V_{CC}$ . This clamp current will prevent forward biasing the IC substrate. Zener diodes are connected to the comparator inputs to enhance the ICs electrostatic discharge capability. Resistors  $R_1$  and  $R_{in}$  must limit the input current to a maximum of  $\pm 2.0$  mA.

Each comparator output consists of an open collector NPN transistor capable of sinking 2.0 mA with a saturation voltage less than 0.4 V, and standing off 40 V with minimal leakage. Internal bias for the Reset and Power Warning Comparators is derived from either  $V_{CC}$  or the regulator output to ensure functionality when either is below nominal.

**Heat Tab Package**

The MC34160 is contained in a 16 lead plastic dual-in-line package in which the die is mounted on a special Heat Tab copper alloy lead frame. This tab consists of the four center ground pins that are specifically designed to improve thermal conduction from the die to the surrounding air. The pictorial in Figure 9 shows a simple but effective method of utilizing the printed circuit board medium as a heat dissipator by soldering these tabs to an adequate area of copper foil. This permits the use of standard board layout and mounting practices while having the ability to more than halve the junction to air thermal resistance. The example and graph are for a symmetrical layout on a single sided board with one ounce per square foot copper.

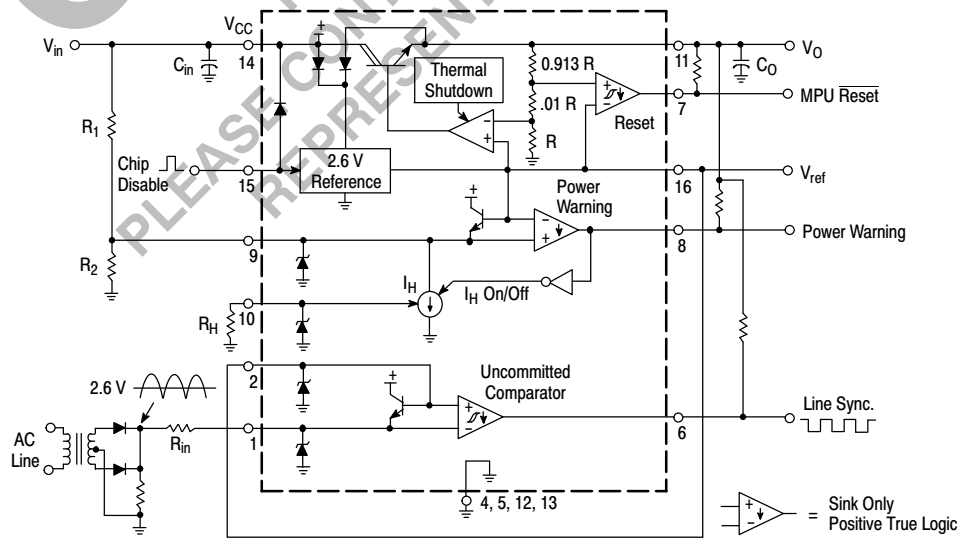

Figure 11. Typical Microprocessor Application



# MC34160, MC33160

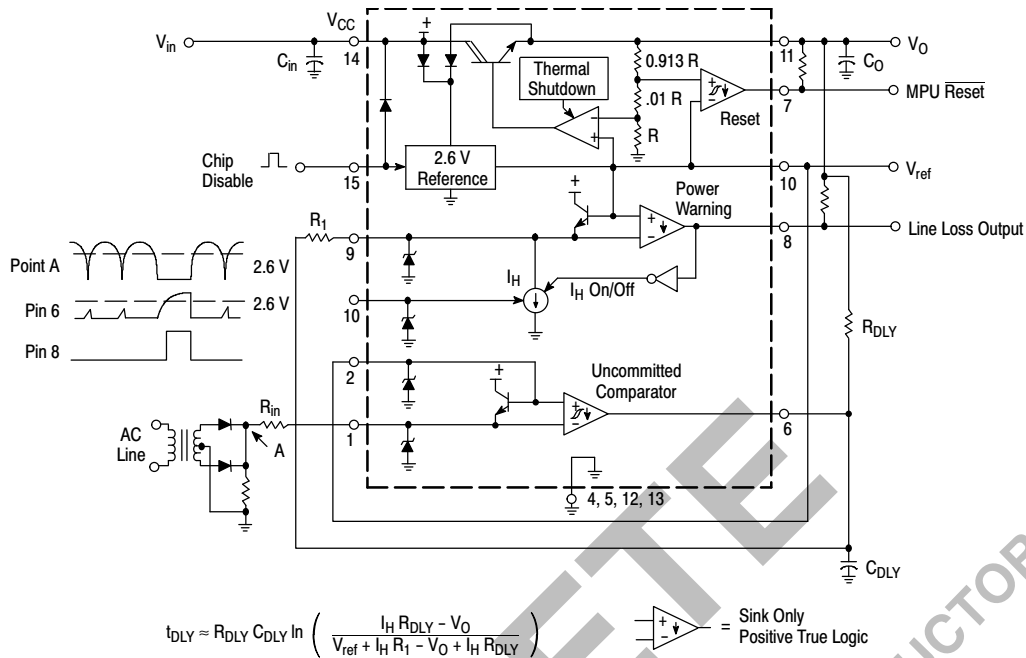

Figure 12. Line Loss Detector Application

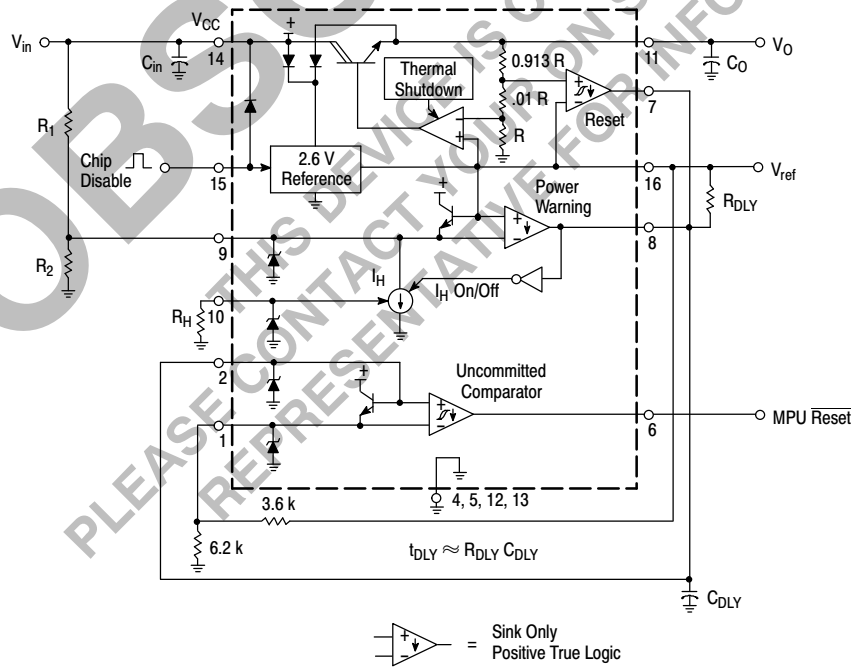

Figure 13. Time Delayed Microprocessor Reset

# MC34160, MC33160

## ORDERING INFORMATION

Device	Operating Temperature Range	Package	Shipping†
MC34160DW	$T_A = 0^\circ \text{ to } +70^\circ\text{C}$	SOIC-16WB	47 Units / Rail
MC34160DWG		SOIC-16WB (Pb-Free)	47 Units / Rail
MC34160DWR2		SOIC-16WB	1000 Units / Tape & Reel
MC34160DWR2G		SOIC-16WB (Pb-Free)	1000 Units / Tape & Reel
MC34160P		PDIP-16	25 Units / Rail
MC34160PG		PDIP-16 (Pb-Free)	25 Units / Rail
MC33160DW	$T_A = -40^\circ \text{ to } +85^\circ\text{C}$	SOIC-16WB	47 Units / Rail
MC33160DWG		SOIC-16WB (Pb-Free)	47 Units / Rail
MC33160DWR2		SOIC-16WB	1000 Units / Tape & Reel
MC33160DWR2G		SOIC-16WB (Pb-Free)	1000 Units / Tape & Reel
MC33160P		PDIP-16	25 Units / Rail
MC33160PG		PDIP-16 (Pb-Free)	25 Units / Rail

†For information on tape and reel specifications, including part orientation and tape sizes, please refer to our Tape and Reel Packaging Specifications Brochure, BRD8011/D.

## MARKING DIAGRAMS

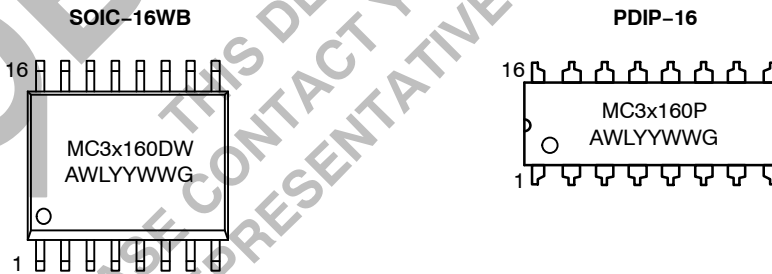

MC3x160 = Device Code  
 DW = SOIC-16  
 P = PDIP-16  
 x = 4 or 3  
 A = Assembly Location  
 WL = Wafer Lot  
 YY = Year  
 WW = Work Week  
 G = Pb-Free Package

# MC34160, MC33160

## PACKAGE DIMENSIONS

SOIC-16 WB  
DW SUFFIX  
PLASTIC PACKAGE  
CASE 751G-03  
ISSUE C

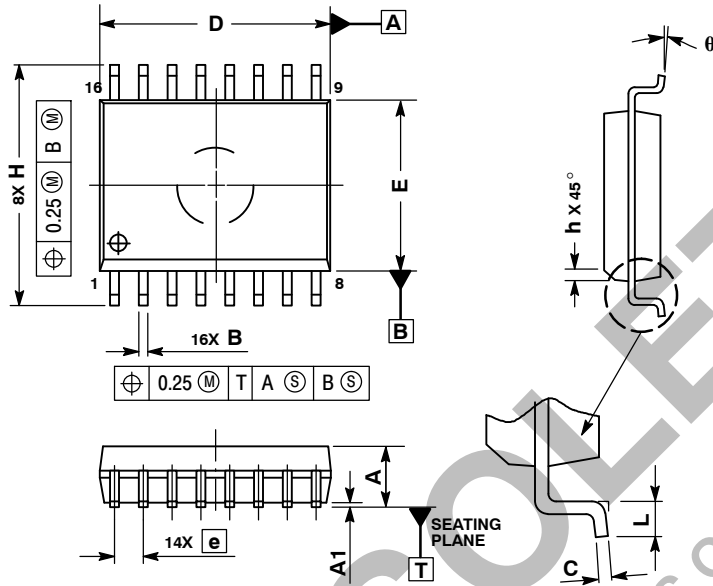

### NOTES:

1. DIMENSIONS ARE IN MILLIMETERS.
2. INTERPRET DIMENSIONS AND TOLERANCES PER ASME Y14.5M, 1994.
3. DIMENSIONS D AND E DO NOT INCLUDE MOLD PROTRUSION.
4. MAXIMUM MOLD PROTRUSION 0.15 PER SIDE.
5. DIMENSION B DOES NOT INCLUDE DAMBAR PROTRUSION. ALLOWABLE DAMBAR PROTRUSION SHALL BE 0.13 TOTAL IN EXCESS OF THE B DIMENSION AT MAXIMUM MATERIAL CONDITION.

DIM	MILLIMETERS	
	MIN	MAX
A	2.35	2.65
A1	0.10	0.25
B	0.35	0.49
C	0.23	0.32
D	10.15	10.45
E	7.40	7.60
e	1.27 BSC	
H	10.05	10.55
h	0.25	0.75
L	0.50	0.90
α	0°	7°

# MC34160, MC33160

## PACKAGE DIMENSIONS

PDIP-16  
P SUFFIX  
PLASTIC PACKAGE  
CASE 648C-04  
ISSUE D

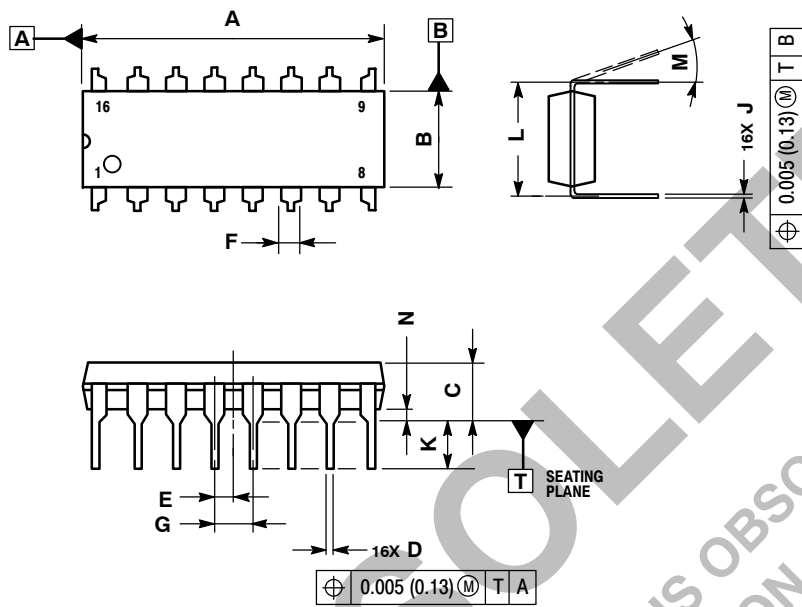

- NOTES:
1. DIMENSIONING AND TOLERANCING PER ASME Y14.5M, 1994.
  2. CONTROLLING DIMENSION: INCH.
  3. DIMENSION L TO CENTER OF LEADS WHEN FORMED PARALLEL.
  4. DIMENSION B DOES NOT INCLUDE MOLD FLASH.

DIM	INCHES		MILLIMETERS	
	MIN	MAX	MIN	MAX
A	0.744	0.783	18.90	19.90
B	0.240	0.260	6.10	6.60
C	0.145	0.185	3.69	4.69
D	0.015	0.021	0.38	0.53
E	0.050 BSC		1.27 BSC	
F	0.040	0.70	1.02	1.78
G	0.100 BSC		2.54 BSC	
J	0.008	0.015	0.20	0.38
K	0.115	0.135	2.92	3.43
L	0.300 BSC		7.62 BSC	
M	0°	10°	0°	10°
N	0.015	0.040	0.39	1.01

**ON Semiconductor** and **ON** are registered trademarks of Semiconductor Components Industries, LLC (SCILLC). SCILLC reserves the right to make changes without further notice to any products herein. SCILLC makes no warranty, representation or guarantee regarding the suitability of its products for any particular purpose, nor does SCILLC assume any liability arising out of the application or use of any product or circuit, and specifically disclaims any and all liability, including without limitation special, consequential or incidental damages. "Typical" parameters which may be provided in SCILLC data sheets and/or specifications can and do vary in different applications and actual performance may vary over time. All operating parameters, including "Typicals" must be validated for each customer application by customer's technical experts. SCILLC does not convey any license under its patent rights nor the rights of others. SCILLC products are not designed, intended, or authorized for use as components in systems intended for surgical implant into the body, or other applications intended to support or sustain life, or for any other application in which the failure of the SCILLC product could create a situation where personal injury or death may occur. Should Buyer purchase or use SCILLC products for any such unintended or unauthorized application, Buyer shall indemnify and hold SCILLC and its officers, employees, subsidiaries, affiliates, and distributors harmless against all claims, costs, damages, and expenses, and reasonable attorney fees arising out of, directly or indirectly, any claim of personal injury or death associated with such unintended or unauthorized use, even if such claim alleges that SCILLC was negligent regarding the design or manufacture of the part. SCILLC is an Equal Opportunity/Affirmative Action Employer. This literature is subject to all applicable copyright laws and is not for resale in any manner.

### PUBLICATION ORDERING INFORMATION

**LITERATURE FULFILLMENT:**  
Literature Distribution Center for ON Semiconductor  
P.O. Box 5163, Denver, Colorado 80217 USA  
**Phone:** 303-675-2175 or 800-344-3860 Toll Free USA/Canada  
**Fax:** 303-675-2176 or 800-344-3867 Toll Free USA/Canada  
**Email:** orderlit@onsemi.com

**N. American Technical Support:** 800-282-9855 Toll Free  
USA/Canada  
**Europe, Middle East and Africa Technical Support:**  
Phone: 421 33 790 2910  
**Japan Customer Focus Center**  
Phone: 81-3-5773-3850

**ON Semiconductor Website:** [www.onsemi.com](http://www.onsemi.com)  
**Order Literature:** <http://www.onsemi.com/orderlit>

For additional information, please contact your local Sales Representative