

MATERIAL NO.	GASKET	TAIL PLATING
757860001	754581001 (SQUARE CUT)	TIN / LEAD
757860002	757270001 (SAW TOOTH)	TIN / LEAD
757865001	754581001 (SQUARE CUT)	TIN
757865002	757270001 (SAW TOOTH)	TIN

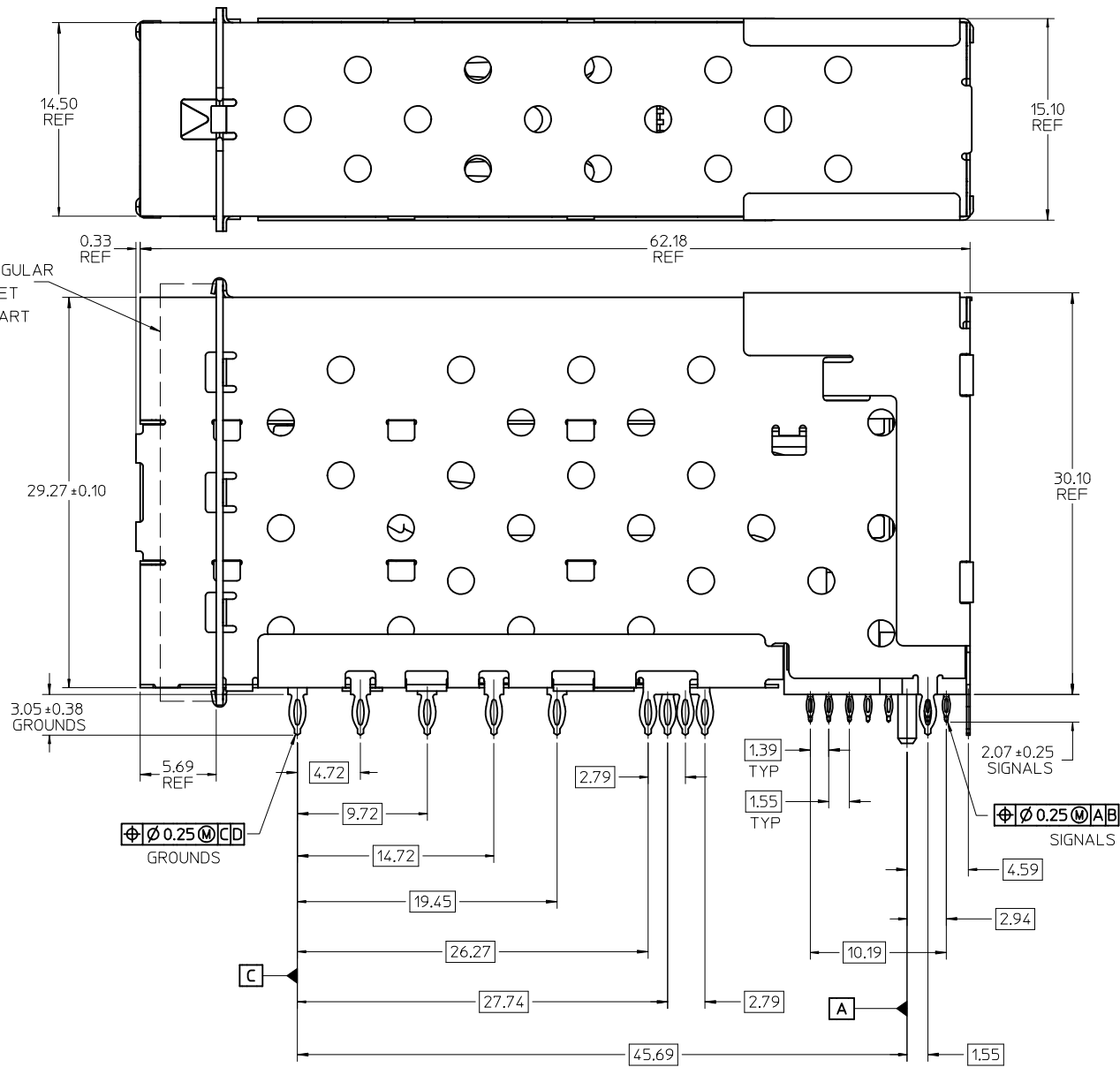

<b>ADD NOTE 8</b> EC NO: UCP2008-0867 DRAWN/SI BARRA 2007/11/13 CHKD/HBARKER 2007/11/30 APPR/S MILLER 2007/12/03	QUALITY SYMBOLS ▼ = 0 ▽ = 0	GENERAL TOLERANCES (UNLESS SPECIFIED) <table border="1"> <thead> <tr> <th></th> <th>mm</th> <th>INCH</th> </tr> </thead> <tbody> <tr> <td>4 PLACES</td> <td>± 0.10</td> <td>± 0.004</td> </tr> <tr> <td>3 PLACES</td> <td>± 0.15</td> <td>± 0.006</td> </tr> <tr> <td>2 PLACES</td> <td>± 0.25</td> <td>± 0.010</td> </tr> <tr> <td>1 PLACE</td> <td>± 0.30</td> <td>± 0.012</td> </tr> </tbody> </table>		mm	INCH	4 PLACES	± 0.10	± 0.004	3 PLACES	± 0.15	± 0.006	2 PLACES	± 0.25	± 0.010	1 PLACE	± 0.30	± 0.012	DIMENSION STYLE <b>MM ONLY</b>	SCALE <b>4:1</b>	DESIGN UNITS <b>METRIC</b>	THIRD ANGLE PROJECTION
		mm	INCH																		
	4 PLACES	± 0.10	± 0.004																		
	3 PLACES	± 0.15	± 0.006																		
2 PLACES	± 0.25	± 0.010																			
1 PLACE	± 0.30	± 0.012																			
DRAWN BY JLONG	DATE 02-07-05	TITLE <b>STACKED SFP 2X1 TALL ASSEMBLY WITH PRESS-FIT TAILS AND LIGHT PIPES</b>																			
CHECKED BY JLONG	DATE 02-07-05	APPROVED BY RNELSON																			
DATE 02-15-2005	MATERIAL NO. <b>SEE CHART</b>	DOCUMENT NO. <b>SD-75786-001</b>	SHEET NO. <b>1 OF 3</b>	MOLEX INCORPORATED																	
DRAFT WHERE APPLICABLE MUST REMAIN WITHIN DIMENSIONS	SIZE <b>C</b>	THIS DRAWING CONTAINS INFORMATION THAT IS PROPRIETARY TO MOLEX INCORPORATED AND SHOULD NOT BE USED WITHOUT WRITTEN PERMISSION																			

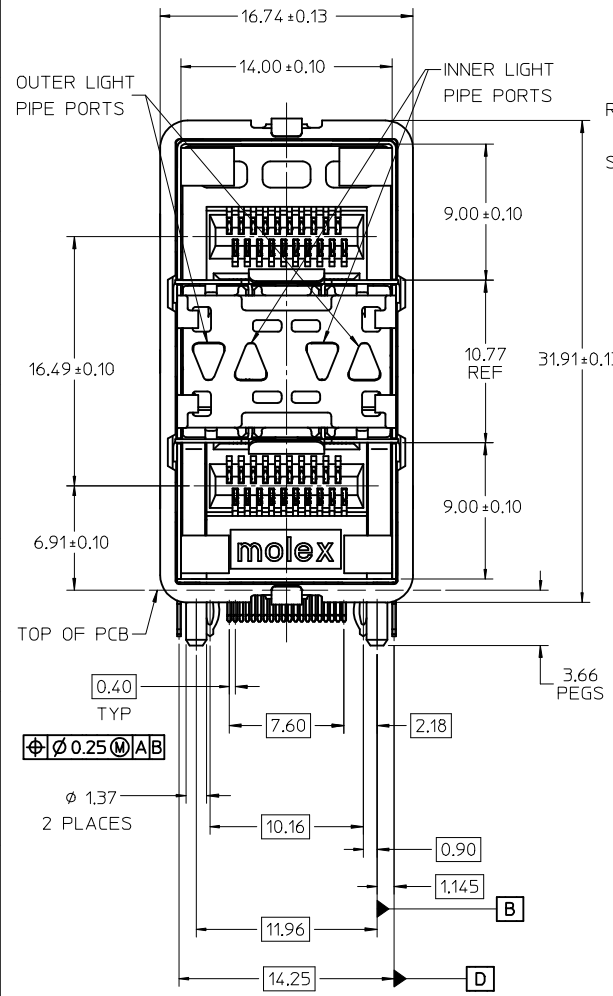
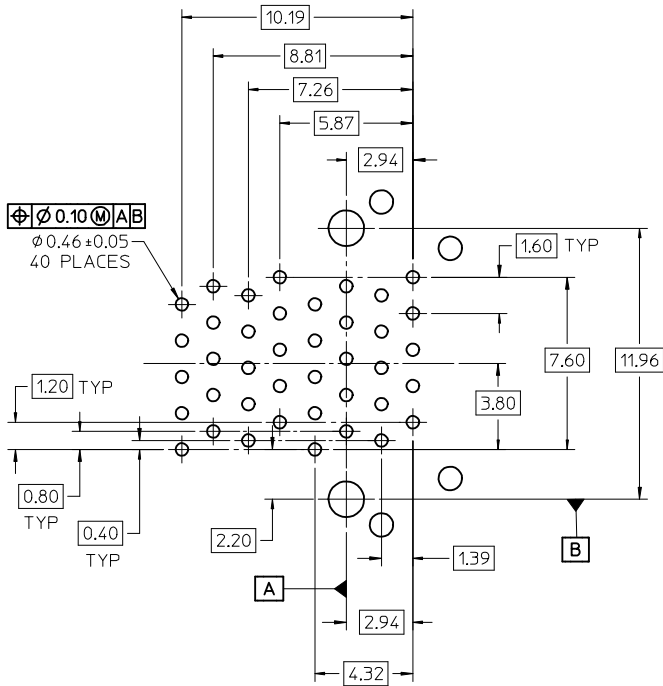

**SIGNAL TAIL PATTERN  
SCALE 6:1**

- NOTES:
- MATERIAL:**  
 CAGE: NICKEL SILVER  
 SFP HOUSING: GLASS FILLED THERMOPLASTIC, UL: 94 V-0, COLOR: BLACK  
 OVER-MOLDED TERMINALS: GLASS FILLED THERMOPLASTIC, UL: 94 V-0, COLOR: BLACK  
 LIGHT PIPE HOUSING: ZINC  
 LIGHT PIPE: POLYCARBONATE UL: 94 V-0, COLOR: CLEAR  
 TERMINALS: BRASS  
 GASKET: LOADED CONDUCTIVE ELASTOMER
  - FINISH:**  
 LIGHT PIPE HSG: 150 MICRONS NICKEL OVER 150 MICRONS COPPER  
 TERMINALS:  
 CONTACT AREA: 0.76 MICRONS MIN. HARD GOLD OVER  
 127 MICRONS MIN NICKEL.  
 COMPLIANT TAIL - TIN/LEAD OPTION: 0.76 - 1.52 MICRONS 90/10 TIN/LEAD  
 OVER 0.76 - 1.52 MICRONS NICKEL  
 COMPLIANT TAIL - TIN OPTION: 0.76 - 1.52 MICRONS TIN  
 OVER 0.76 - 1.52 MICRONS NICKEL
  - REFER TO PS-75310-001 PRODUCT SPEC FOR ALL ELECTRICAL, MECHANICAL AND ENVIRONMENTAL SPECIFICATIONS.
  - REFER TO PK-75310-001 FOR ALL PACKAGING SPECIFICATIONS.
  - PROCESSING: WAVE SOLDER (NOT REFLOW COMPATIBLE).
  - LIGHT PIPE PAD LAYOUT SHOWN IS FOR AN 0805 LOW-PROFILE LED PACKAGE. FOR OTHER RECOMMENDED LAYOUTS REFER TO MOLEX'S REPORT TS-75310-001.
  - THE CURVED TAILS THAT GO INTO THE HOLES LOCATED BY THESE DIMENSIONS ARE BEING ELIMINATED, TO ACCOMMODATE THIS CONVERSION, IT IS RECOMMENDED THAT BOARDS DESIGNED TO THIS PRINT REVISION INCLUDE THESE HOLES.
  - PART COMPLIES WITH COSMETIC SPECIFICATION PS-45499-002. SEE SHEET 3 SECTION Z-Z FOR SURFACE CLASSIFICATIONS. UNDERSIDE OF CAGE COMPLIES WITH CLASS "C".

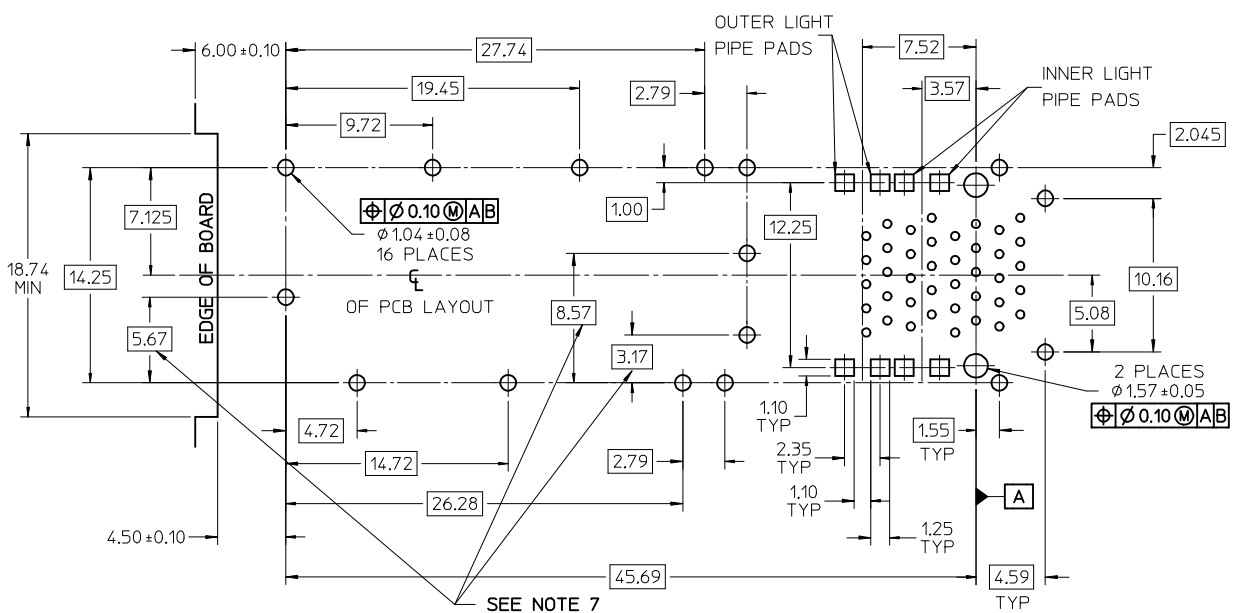

**RECOMMENDED PCB LAYOUT  
PCB THICKNESS 2.36  
COMPONENT SIDE**

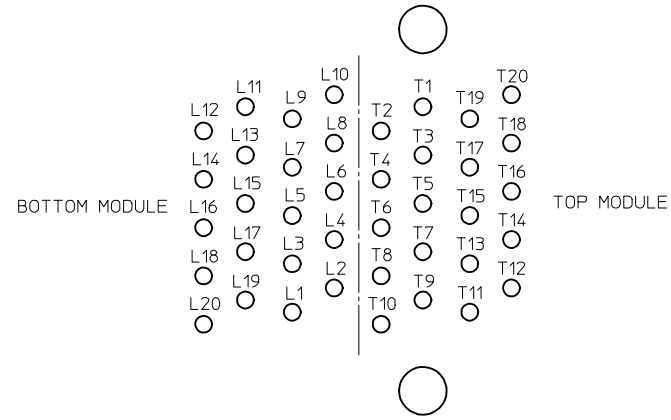

**CONNECTOR PIN-OUT  
SCALE 8:1**

<b>ADD NOTE 8</b> EC NO: UCP2008-0867 DRAWN: SI BARRA 2007/11/13 CHKD: BARKER 2007/11/30 APPR: MILLER 2007/12/03	QUALITY SYMBOLS ▽=0 ▽=0	GENERAL TOLERANCES (UNLESS SPECIFIED) <table border="1"> <tr> <th></th> <th>mm</th> <th>INCH</th> </tr> <tr> <td>4 PLACES ±</td> <td>---</td> <td>---</td> </tr> <tr> <td>3 PLACES ±</td> <td>---</td> <td>---</td> </tr> <tr> <td>2 PLACES ±</td> <td>0.25</td> <td>---</td> </tr> <tr> <td>1 PLACE ±</td> <td>---</td> <td>---</td> </tr> </table>		mm	INCH	4 PLACES ±	---	---	3 PLACES ±	---	---	2 PLACES ±	0.25	---	1 PLACE ±	---	---	DIMENSION STYLE <b>MM ONLY</b> DRAWN BY: JLONG DATE: 02-07-05 CHECKED BY: JLONG DATE: 02-07-05 APPROVED BY: RNELSON DATE: 02-15-2005	SCALE: 4:1 DESIGN UNITS: METRIC THIRD ANGLE PROJECTION	STACKED SFP 2X1 TALL ASSEMBLY WITH PRESS-FIT TAILS AND LIGHT PIPES <b>MOLEX INCORPORATED</b>	SHEET NO. 2 OF 3
		mm	INCH																		
4 PLACES ±	---	---																			
3 PLACES ±	---	---																			
2 PLACES ±	0.25	---																			
1 PLACE ±	---	---																			
DRAFT WHERE APPLICABLE MUST REMAIN WITHIN DIMENSIONS	MATERIAL NO. <b>SEE CHART</b>	DOCUMENT NO. <b>SD-75786-001</b>	THIS DRAWING CONTAINS INFORMATION THAT IS PROPRIETARY TO MOLEX INCORPORATED AND SHOULD NOT BE USED WITHOUT WRITTEN PERMISSION																		

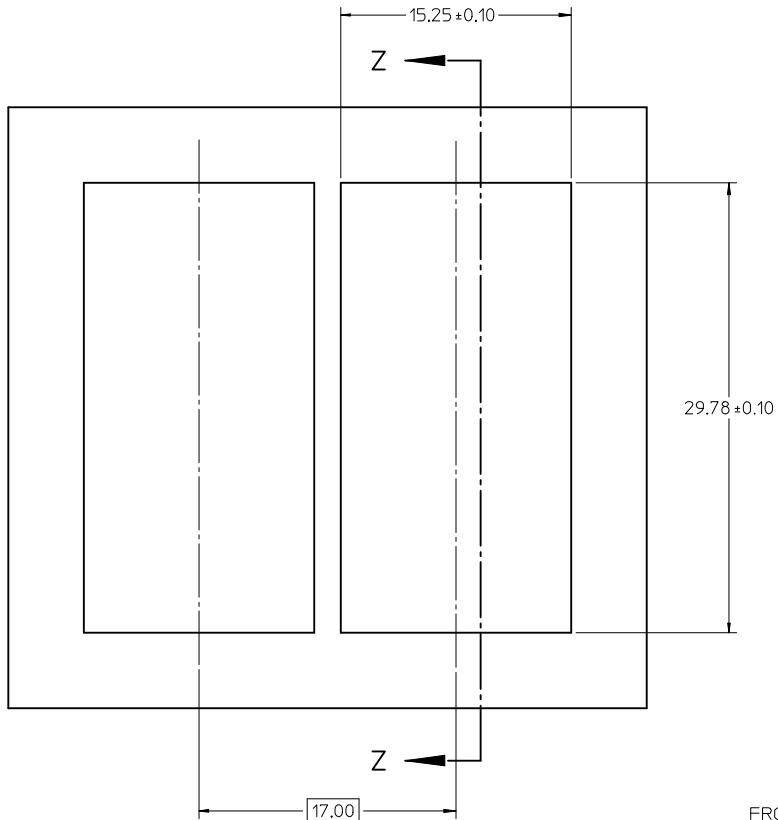

BEZEL CUT-OUT CENTER DETAIL  
BEZEL THICKNESS 0.8 -2.6

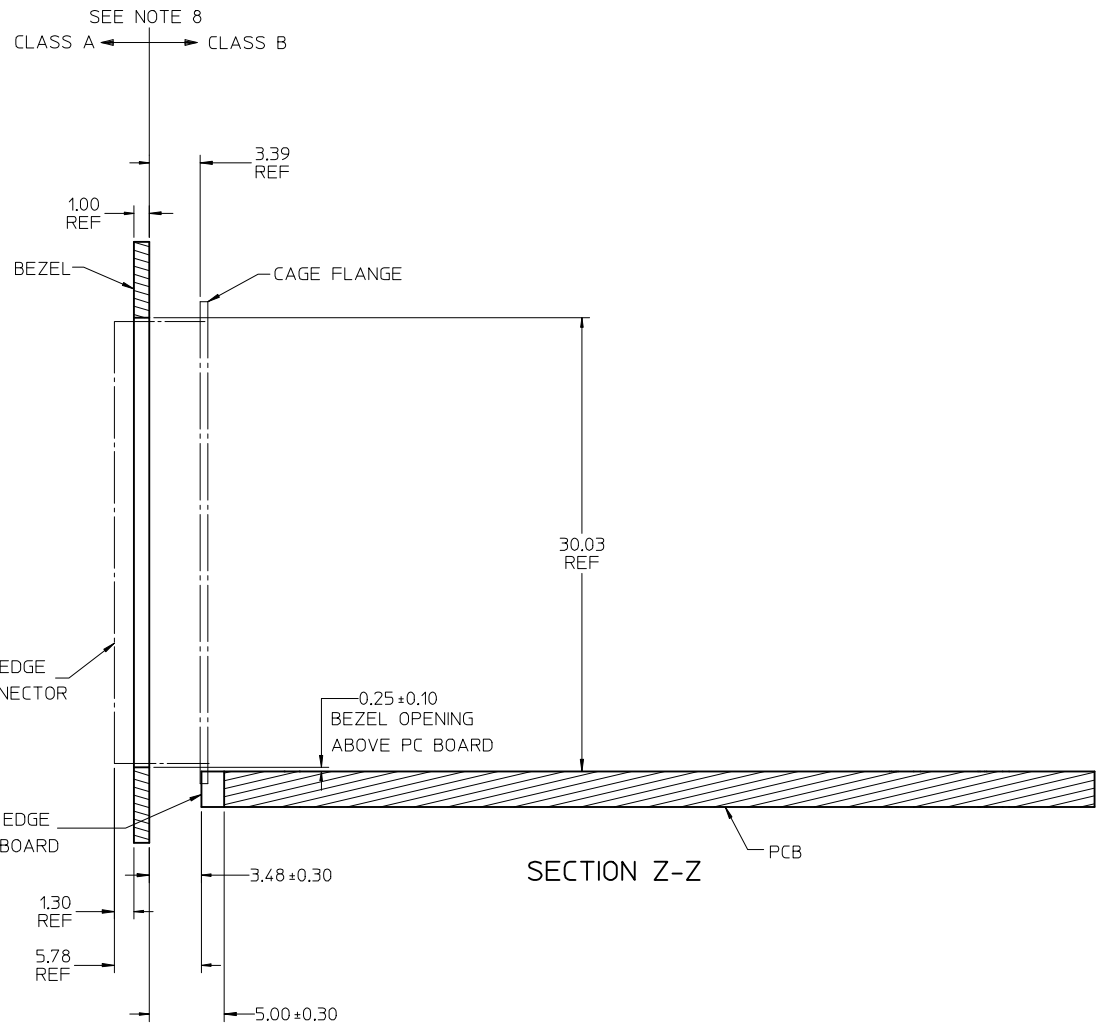
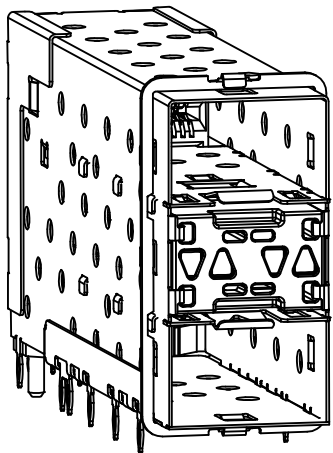

<b>COSMETIC CLASS</b> EC NO: UCP2008-0867 DRWN:MSI BARRA 2007/11/13 CHKD:BBARKER 2007/11/30 APPR:SMILLER 2007/12/03	QUALITY SYMBOLS ▽=0 ▽=0	GENERAL TOLERANCES (UNLESS SPECIFIED) <table border="1"> <tr> <th></th> <th>mm</th> <th>INCH</th> </tr> <tr> <td>4 PLACES</td> <td>± ---</td> <td>± ---</td> </tr> <tr> <td>3 PLACES</td> <td>± ---</td> <td>± ---</td> </tr> <tr> <td>2 PLACES</td> <td>± 0.25</td> <td>± ---</td> </tr> <tr> <td>1 PLACE</td> <td>± ---</td> <td>± ---</td> </tr> </table>		mm	INCH	4 PLACES	± ---	± ---	3 PLACES	± ---	± ---	2 PLACES	± 0.25	± ---	1 PLACE	± ---	± ---	DIMENSION STYLE <b>MM ONLY</b>	SCALE <b>4:1</b>	DESIGN UNITS <b>METRIC</b>	THIRD ANGLE PROJECTION
		mm	INCH																		
	4 PLACES	± ---	± ---																		
	3 PLACES	± ---	± ---																		
2 PLACES	± 0.25	± ---																			
1 PLACE	± ---	± ---																			
DESCRIPTION REV D	DRAFT WHERE APPLICABLE MUST REMAIN WITHIN DIMENSIONS	DRAWN BY JLONG	DATE 02-07-05	TITLE <b>STACKED SFP 2X1 TALL ASSEMBLY WITH PRESS-FIT TAILS AND LIGHT PIPES</b>																	
		CHECKED BY JLONG	DATE 02-07-05	MOLEX INCORPORATED																	
		APPROVED BY RNELSON	DATE 02-15-2005	MATERIAL NO. <b>SEE CHART</b>	DOCUMENT NO. <b>SD-75786-001</b>	SHEET NO. <b>3 OF 3</b>															