



---

## Power Double Lock Connector System

---

### 1. SCOPE

#### 1.1. Content

This specification covers performance, tests, and quality requirements for the Power Double Lock Connector System.

#### 1.2. Qualification

When tests are performed on the subject product line, procedures specified in Figure 1 shall be used. All inspections shall be performed using the applicable inspection plan and product drawing.

#### 1.3. Qualification Test Results

Successful qualification testing on the subject product line was completed between 22Nov94 and 20Oct95. The Qualification Test Report number for this testing is 501-5146. Additional successful qualification testing on the subject product line was completed between 08Aug95 and 14Oct95. The Qualification Test Report number for this testing is 501-5169.

#### 1.4. Revision Summary

Revisions to this specification include:

- Added random vibration testing to Figure 1 and test group 19 in Figure 9
- Added Figure 8 to include PN 2232901-2 and 177917-3

### 2. APPLICABLE DOCUMENTS AND FORMS

The following documents form a part of this specification to the extent specified herein. Unless otherwise specified, the latest edition of the document applies. In the event of conflict between the requirements of this specification and the product drawing, the product drawing shall take precedence. In the event of conflict between the requirements of this specification and the referenced documents, this specification shall take precedence.

#### 2.1. TE Connectivity Specifications

|          |  |
|----------|--|
| 114-5175 | Application Specification – Power Double Lock Connector System                 |
| 501-5146 | Qualification Test Report – Power Double Lock Connector System (Wire to Wire)  |
| 501-5169 | Qualification Test Report – Power Double Lock Connector System (Wire to Board) |

#### 2.2. Commercial Standards and Specifications

|           |   |
|-----------|---|
| IEC 60512 | International Standard – Connectors for Electronic Equipment – Tests and Measurements |
| EIA-364   | Electrical Connector/Socket Test Procedures Including Environmental Classifications   |

#### 2.3. Reference Documents

|         |   |
|---------|---|
| 109-1   | General Requirements for Testing                |
| 102-950 | Qualification of Separable Interface Connectors |

### 3. REQUIREMENTS

#### 3.1. Design and Construction

Product shall be of the design, construction, materials and physical dimensions specified on the applicable product drawing.

3.2. Materials

Materials used in the construction of this product shall be as specified on the applicable TE drawing.

3.3. Ratings

A. Voltage Rating:

- 300 VAC (all configurations except 3.96 mm wire-to-board configuration)
- 50 VAC (3.96 mm wire-to-board configuration only)

B. Current Rating: See Figure 6, Figure 7, and Figure 8

C. Temperature Rating: -30°C to +105°C (includes ambient temperature plus thermal increase due to current flow)

D. Minimum Ratings: 1 mV, 1 µA (minimum)

E. Applicable PCB

- Thickness: 1.6 mm
- Diameter of Hole:
  - For Tine: 1.25±0.05 (punched hole), 1.40±0.05 (drilled hole)
  - For Boss: 2.20±0.05 (punched hole and drilled hole)

3.4. Performance Requirements and Test Description

The product should meet the electrical, mechanical and environmental performance requirements specified in Figure 1. All tests shall be performed at ambient environmental conditions otherwise specified.

3.5. Test Requirements and Procedure Summary

| Test Description                                      | Requirement  | Procedure  |
|---|--|--|
| Examination of Product                                | Meets requirements of product drawing and application specification (114-5175). After testing, parts shall show no damage of physical change detrimental to product performance. | EIA-364-18<br>Visually inspected per applicable inspection plan. Precondition parts for 24 hours prior to testing.   |
| <b>Electrical</b>                                     |  |  |
| Termination Resistance (Low Level Contact Resistance) | Initial: 10 mΩ (maximum)<br>Final: 20 mΩ (maximum)   | EIA-364-23<br>Measure as per the connection in Figure 2 and Figure 3. Subtract the bulk resistance of the wire from the measurement. (Protect wire from corrosion during testing.) Test on mated connector.<br>Test Current: <100 mA<br>Test Voltage: <20 mV |
| Insulation Resistance                                 | Initial: 1000 MΩ (minimum)<br>Final: 500 MΩ (minimum)  | EIA-364-21<br>Apply 500 VDC and hold for 2 minutes. Test between contacts in adjacent circuits and between housing and contacts in a mated connector.  |
| Dielectric Withstanding Voltage                       | 1 minute hold without a creep discharge or flashover.<br>Current Leakage: 5 mA (maximum)   | EIA-364-20, Method A, Condition 1<br>Hold at 2.2 kV AC at sea level for 1 minute.<br>Current Leakage: 5 mA (maximum)<br>Test between contacts in adjacent circuits and between housing and all contacts in a mated connector.                                |

**Figure 1 (continued)**

|                              |  |  |
|------------------------------|--|--|
| Temperature Rise vs. Current | 30°C maximum when subjected to rated current   | EIA-364-70, Method 1<br>Measure the temperature rise above ambient created by the energizing current. Measurement must be taken at a place where there is no influence from air convection. Contacts to be assembled in housing with all circuits connected. The thermocouple is to be attached to the contact in the center circuit. Stabilize at a single current level until 3 readings at 5 minute intervals are within 1°C. See Figure 2, Figure 3, Figure 6, Figure 7, and Figure 8. |
| <b>Mechanical</b>            |  |  |
| Sinusoidal Vibration         | No electrical discontinuity greater than 1 $\mu$ s shall occur.<br>No physical damage that would impair product performance. | EIA-364-28, Condition I<br>Subject mated connector to 10-55-10 Hz traversed in 1 minute at 1.52 mm amplitude. Apply 2 hours in each of 3 mutually perpendicular planes. 100 mA applied.  |
| Random Vibration             | No electrical discontinuity greater than 1 $\mu$ s shall occur.<br>No physical damage that would impair product performance. | EIA-364-28, Test Condition VII, Level D<br>Subject mated connector to 3.10G's RMS between 20 and 500 Hz. Apply 15 minutes in each of 3 mutually perpendicular planes. See Figure 4.  |
| Mechanical Shock             | No electrical discontinuity greater than 1 $\mu$ s shall occur.<br>No physical damage that would impair product performance. | EIA-364-27, Condition A<br>Subject mated connector to 50G's half-sine shock pulse of 11 ms duration. 3 drops each to normal and reversed directions of X, Y and Z axis. Total of 18 drops. See Figure 4.   |
| Connector Mating Force       | Normal Type: (6.86 x # of Positions) N (maximum)<br>High Pressure Type: (9.8 x # of Positions) N (maximum)                   | EIA-364-13, Method A<br>Operation Speed: 100 mm/min<br>Measure the force required to mate connectors without locking latches.  |
| Connector Unmating Force     | Normal Type: (1.47 x # of Positions) N (maximum)<br>High Pressure Type: (1.96 x # of Positions) N (maximum)                  | EIA-364-13, Method A<br>Operation Speed: 100 mm/min<br>Measure the force required to unmate connectors without locking latches.  |
| Contact Insertion Force      | 6.86 N (maximum) per contact   | EIA-364-5<br>Measure the force required to insert contact into housing.  |
| Contact Retention Force      | 41.16 N (minimum)  | EIA-364-29, Method A<br>Operation Speed: 100 mm/min<br>Measure the axial force required to remove contact crimped to 16 AWG or 18 AWG wire from the housing.   |
| Contact Mating Force         | Normal Type: 6.86 N (maximum)<br>High Pressure Type: 9.8 N (maximum)   | EIA-364-37, Method A<br>Operation Speed: 100 mm/min<br>Measure force required to mate contact to gage tab per dimensions in Figure 5.  |

Figure 1 (continued)

| Contact Unmating Force             | <p>Normal Type:<br/>           First Unmating: 0.34 N (minimum)<br/>           25<sup>th</sup> Unmating: 0.25 N (minimum)</p> <p>High Pressure Type:<br/>           First Unmating: 0.58 N (minimum)<br/>           25<sup>th</sup> Unmating: 0.39 N (minimum)</p>  | <p>EIA-364-37, Method A</p> <p>Operation Speed: 100 mm/min</p> <p>Measure force required to unmate contact to gage tab per dimensions in Figure 5.</p>  |                                   |           |          |           |          |           |          |           |          |           |          |           |          |   |
|------------------------------------|---|---|-----------------------------------|-----------|----------|-----------|----------|-----------|----------|-----------|----------|-----------|----------|-----------|----------|---|
| Crimp Tensile Strength             | <table border="1"> <thead> <tr> <th>Wire Size (AWG [mm<sup>2</sup>])</th> <th>Crimp Tensile (minimum) (N [kgf])</th> </tr> </thead> <tbody> <tr> <td>26 [0.14]</td> <td>19.6 [2]</td> </tr> <tr> <td>24 [0.22]</td> <td>29.4 [3]</td> </tr> <tr> <td>22 [0.31]</td> <td>49.0 [5]</td> </tr> <tr> <td>20 [0.51]</td> <td>58.8 [6]</td> </tr> <tr> <td>18 [0.87]</td> <td>68.6 [7]</td> </tr> <tr> <td>16 [1.27]</td> <td>78.4 [8]</td> </tr> </tbody> </table> | Wire Size (AWG [mm <sup>2</sup> ])  | Crimp Tensile (minimum) (N [kgf]) | 26 [0.14] | 19.6 [2] | 24 [0.22] | 29.4 [3] | 22 [0.31] | 49.0 [5] | 20 [0.51] | 58.8 [6] | 18 [0.87] | 68.6 [7] | 16 [1.27] | 78.4 [8] | <p>EIA-364-8</p> <p>Operation Speed: 100 mm/min</p> <p>Apply an axial pull force to the crimped wire.</p> <p>Contact to be secured to the tester. Insulation barrel crimp to be disabled.</p> |
| Wire Size (AWG [mm <sup>2</sup> ]) | Crimp Tensile (minimum) (N [kgf])   |   |                                   |           |          |           |          |           |          |           |          |           |          |           |          |   |
| 26 [0.14]                          | 19.6 [2]  |   |                                   |           |          |           |          |           |          |           |          |           |          |           |          |   |
| 24 [0.22]                          | 29.4 [3]  |   |                                   |           |          |           |          |           |          |           |          |           |          |           |          |   |
| 22 [0.31]                          | 49.0 [5]  |   |                                   |           |          |           |          |           |          |           |          |           |          |           |          |   |
| 20 [0.51]                          | 58.8 [6]  |   |                                   |           |          |           |          |           |          |           |          |           |          |           |          |   |
| 18 [0.87]                          | 68.6 [7]  |   |                                   |           |          |           |          |           |          |           |          |           |          |           |          |   |
| 16 [1.27]                          | 78.4 [8]  |   |                                   |           |          |           |          |           |          |           |          |           |          |           |          |   |
| Durability                         | No physical damage that would impair product performance.   | <p>EIA-364-9</p> <p>Manually mate and unmate connectors for 25 cycles.</p>  |                                   |           |          |           |          |           |          |           |          |           |          |           |          |   |
| Housing Panel Retention Force      | 98 N (minimum)  | <p>EIA-364-97</p> <p>Operation Speed: 100 mm/min.</p> <p>Measure panel retention force using a panel cut with nominal dimensions as specified in the TE customer drawing.</p>   |                                   |           |          |           |          |           |          |           |          |           |          |           |          |   |
| Housing Locking Strength           | <p>2P-4P Housing: 34.3 N (minimum)</p> <p>6P, 8P, 9P, 10P, 12P: 44.1 N (minimum)</p>  | <p>EIA-364-98</p> <p>Operation Speed: 100 mm/min</p> <p>Ensure that locking latches are fully engaged.</p>  |                                   |           |          |           |          |           |          |           |          |           |          |           |          |   |
| Post Retention Force               | 19.6 N (minimum)  | <p>EIA-364-29</p> <p>Operation Speed: 100 mm/min</p> <p>Measure post retention force.</p>   |                                   |           |          |           |          |           |          |           |          |           |          |           |          |   |
| <b>Environmental</b>               |   |   |                                   |           |          |           |          |           |          |           |          |           |          |           |          |   |
| Thermal Shock                      | No physical damage that would impair product performance.   | <p>EIA-364-32, Method A, Test Condition I</p> <p>Subject mated specimens to 25 cycles between -55°C and 85°C with 30 minute dwell time at temperature extremes and 5 minute transition (maximum) between temperatures.</p> <p>Measurements to be recorded after specimens are held for 3 hours at ambient temperature and humidity.</p> |                                   |           |          |           |          |           |          |           |          |           |          |           |          |   |
| Humidity-Temperature Cycling       | No physical damage that would impair product performance.   | <p>EIA-364-31, Method IV</p> <p>Subject mated specimen to 10 cycles between 25°C and 65°C at 80-98% RH.</p> <p>Measurements to be recorded after specimens are held for 3 hours at ambient temperature and humidity.</p> <p>1 cycle is 24 hours.</p>  |                                   |           |          |           |          |           |          |           |          |           |          |           |          |   |
| Salt Spray                         | No physical damage that would impair product performance.   | <p>EIA-364-26, Condition B</p> <p>Subject mated connectors to 5±1% salt concentration for 48 hours.</p>   |                                   |           |          |           |          |           |          |           |          |           |          |           |          |   |

**Figure 1 (continued)**

|                              |   |   |
|------------------------------|---|---|
| Temperature Life             | No physical damage that would impair product performance. | EIA-364-17, Method A, Test Condition A, Test Condition 4<br>Subject mated connector to 105°C for a duration of 96 hours.<br>Measurements to be recorded after specimens are held for 3 hours at ambient temperature and humidity. |
| Resistance to Cold           | No physical damage that would impair product performance. | IEC 60512-11-10<br>Subject mated connector to -30°C ± 2°C for 96 hours.   |
| Solderability                | Wet Solder Coverage: 90% (minimum)                        | MIL-STD-202 Method 208<br>Solder Temperature: 245±5°C<br>Immersion Duration: 3±0.5 seconds  |
| Resistance to Soldering Heat | No physical damage that would impair product performance. | TE Spec. 109-202 Condition C<br>Solder Temperature: 260 +0/-5°C<br>Immersion Duration: 5 +2/-0 Sec  |
| Hydrogen Sulfide             | No physical damage that would impair product performance. | Subject mated specimens to 3 ± 1 ppm H <sub>2</sub> S gas concentration maintained at 40 ± 2°C for 96 hours.  |
| Ammonia                      | No physical damage that would impair product performance. | Subject mated specimens in atmosphere that rated 25 mL/L of 3% NH <sub>3</sub> for 7 hours.   |

Figure 1 (end)



**NOTE**

Shall meet visual requirements, show no physical damage, and meet requirements of additional tests as specified in the Product Qualification and Requalification Test Sequence shown in Figure 9.

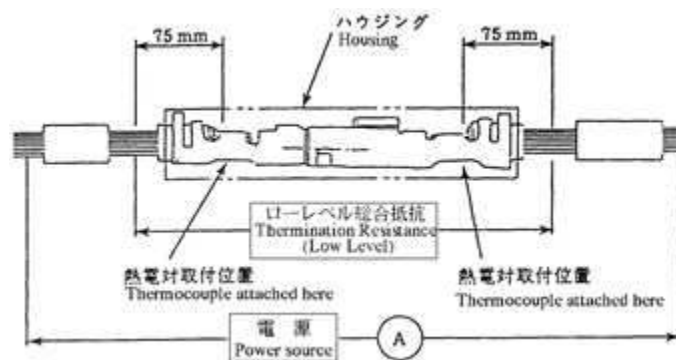
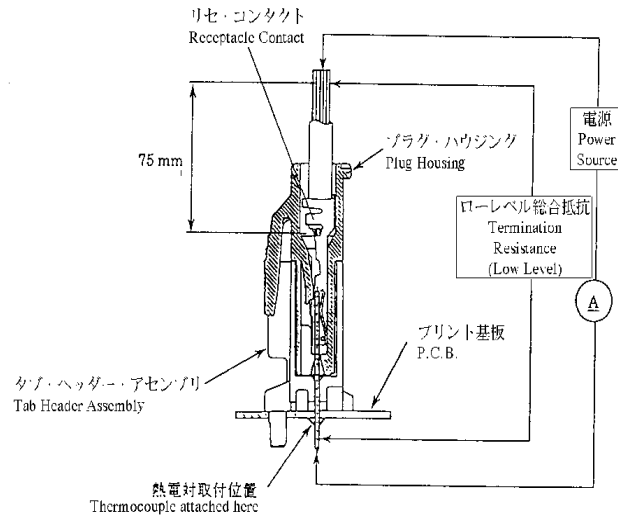

Figure 2: Termination Resistance Measurement Points and Temperature Rise Set-up for Wire to Wire Configuration



**NOTE**

Subtract the bulk resistance of the 150 mm wire leads from the final measurement.

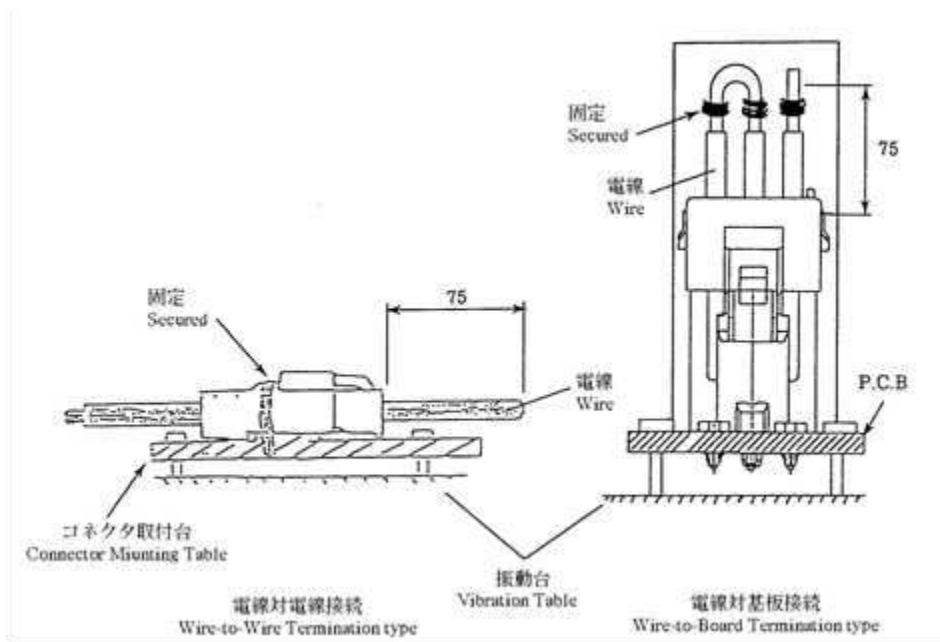

**Figure 3:** Termination Resistance Measurement Points and Temperature Rise Set-up for Wire to Board Configuration



**NOTE**

Subtract the bulk resistance of the 75 mm wire leads from the final measurement.



**Figure 4:** Connector Mounting Methods of Low Frequency Vibration and Mechanical Shock Tests

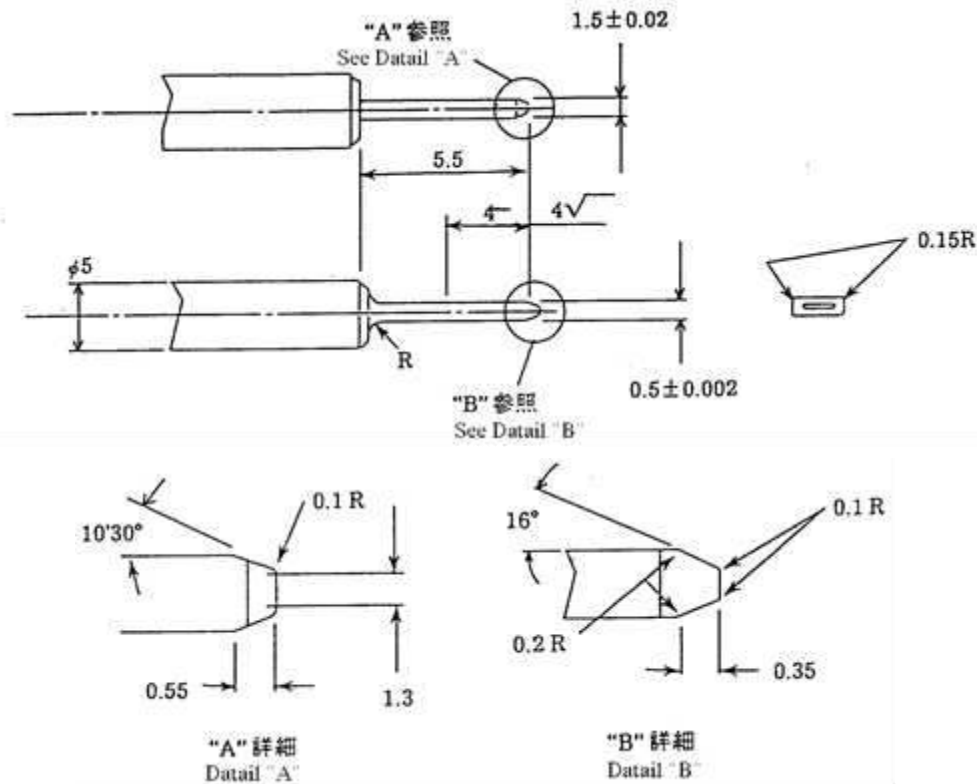

Figure 5: Gage Design for Contact Mating/Unmating Force Testing

| Position | Receptacle Contact: 177915-*,2238096-1<br>Tab Contact: 177917-1,177917-2,2323853-1 |        |        | Receptacle Contact: 177914-<br>Tab Contact: 177916-1 |        |        |
|----------|--|--------|--------|--|--------|--------|
|          | 16 AWG   | 18 AWG | 20 AWG | 22 AWG   | 24 AWG | 26 AWG |
| 1P-2P    | 14 A   | 8 A    | 7 A    | 5 A  | 4 A    | 3 A    |
| 3P       | 9 A  | 7 A    | 6 A    | 4 A  | 3 A    | 2 A    |
| 4P       | 9 A  | 7 A    | 6 A    | 4 A  | 3 A    | 2 A    |
| 6P       | 8 A  | 6 A    | 5 A    | 3 A  | 2 A    | 2 A    |
| 8P       | 8 A  | 6 A    | 5 A    | 3 A  | 2 A    | 2 A    |
| 9P       | 8 A  | 6 A    | 5 A    | 3 A  | 2 A    | 2 A    |
| 10P      | 7 A  | 5 A    | 4 A    | 2 A  | 2 A    | 2 A    |
| 12P      | 7 A  | 5 A    | 4 A    | 2 A  | 2 A    | 2 A    |

Figure 6



**NOTE**

These currents are expected to produce an initial 30°C temperature rise (maximum) at the contacts. The temperature rise at the end of consecutive sequential testing (i.e. humidity-temperature cycling, temperature life, and vibration) may be higher.

|          | Receptacle Contact: 2323832-1, 2232901-1,<br>1-2232901-1<br>Tab Contact: 177917-1, 177917-2, 2323853-1 |        |        | Receptacle Contact: 2232902-1, 1-2232902-1<br>Tab Contact: 177916-1 |        |        |
|----------|--|--------|--------|---|--------|--------|
| Position | 16 AWG   | 18 AWG | 20 AWG | 22 AWG  | 24 AWG | 26 AWG |
| 1P-2P    | 12 A   | 8 A    | 7 A    | 5 A   | 4 A    | 3 A    |
| 3P       | 9 A  | 7 A    | 6 A    | 4 A   | 3 A    | 2 A    |
| 4P       | 9 A  | 7 A    | 6 A    | 4 A   | 3 A    | 2 A    |
| 6P       | 8 A  | 6 A    | 5 A    | 3 A   | 2 A    | 2 A    |
| 8P       | 8 A  | 6 A    | 5 A    | 3 A   | 2 A    | 2 A    |
| 9P       | 8 A  | 6 A    | 5 A    | 3 A   | 2 A    | 2 A    |
| 10P      | 7 A  | 5 A    | 4 A    | 2 A   | 2 A    | 2 A    |
| 12P      | 7 A  | 5 A    | 4 A    | 2 A   | 2 A    | 2 A    |

Figure 7



**NOTE**

*These currents are expected to produce an initial 30°C temperature rise (maximum) at the contacts. The temperature rise at the end of consecutive sequential testing (i.e. humidity-temperature cycling, temperature life, and vibration) may be higher.*

|          | Receptacle Contact: 2232901-2<br>Tab Contact: 177917-3 |        |        |
|----------|--|--------|--------|
| Position | 16 AWG   | 18 AWG | 20 AWG |
| 1P-2P    | 14 A   | 9.3 A  | 8.1 A  |
| 3P       | 10.5 A   | 8.1 A  | 7 A    |
| 4P       | 10.5 A   | 8.1 A  | 7 A    |
| 6P       | 9.3 A  | 7 A    | 5.8 A  |
| 8P       | 9.3 A  | 7 A    | 5.8 A  |
| 9P       | 9.3 A  | 7 A    | 5.8 A  |
| 10P      | 8 A  | 5.8 A  | 4.6 A  |
| 12P      | 8 A  | 5.8 A  | 4.6 A  |

Figure 8



**NOTE**

*These currents are expected to produce a final (at the end of consecutive testing, i.e. humidity-temperature cycling, temperature life, and vibration) 30°C temperature rise (maximum) at the contacts.*



3.6. Product Qualification and Requalification Test Sequence

| TEST OR EXAMINATION                | TEST GROUP (a)    |      |      |   |      |      |         |      |      |      |      |      |      |      |      |      |      |      |       |      |
|------------------------------------|-------------------|------|------|---|------|------|---------|------|------|------|------|------|------|------|------|------|------|------|-------|------|
|                                    | 1                 | 2    | 3    | 4 | 5    | 6    | 7(c)    | 8    | 9    | 10   | 11   | 12   | 13   | 14   | 15   | 16   | 17   | 18   | 19(d) |      |
|                                    | TEST SEQUENCE (b) |      |      |   |      |      |         |      |      |      |      |      |      |      |      |      |      |      |       |      |
| Examination of Product             | 1, 3              | 1, 4 | 1, 4 | 1 | 1, 3 | 1, 4 | 1, 7    | 1, 7 | 1, 4 | 1, 4 | 1, 4 | 1, 4 | 1, 4 | 1, 4 | 1, 4 | 1, 4 | 1, 3 | 1, 3 | 1, 3  | 1, 9 |
| Termination Resistance (Low Level) |                   |      |      |   |      |      | 2, 4, 6 | 3, 6 | 2, 5 | 2, 5 | 2, 5 | 2, 5 | 2, 5 | 2, 5 | 2, 5 |      |      |      |       | 2, 7 |
| Dielectric Withstanding Voltage    |                   |      |      |   |      | 3    |         |      |      | 7    |      |      |      |      |      |      |      |      |       |      |
| Insulation Resistance              |                   |      |      |   |      | 2    |         |      |      | 6    |      |      |      |      |      |      |      |      |       |      |
| Temperature Rise                   |                   |      |      |   | 2    |      |         |      |      |      |      |      |      |      |      |      |      |      |       | 3, 8 |
| Sinusoidal Vibration               |                   |      |      |   |      |      | 5       |      |      |      |      |      |      |      |      |      |      |      |       |      |
| Mechanical Shock                   |                   |      |      |   |      |      | 3       |      |      |      |      |      |      |      |      |      |      |      |       |      |
| Connector Mating Force             |                   |      |      |   |      |      |         | 2    |      |      |      |      |      |      |      |      |      |      |       |      |
| Connector Unmating Force           |                   |      |      |   |      |      |         | 4    |      |      |      |      |      |      |      |      |      |      |       |      |
| Contact Insertion Force            |                   |      |      | 2 |      |      |         |      |      |      |      |      |      |      |      |      |      |      |       |      |
| Contact Mating Force               |                   | 2    |      |   |      |      |         |      |      |      |      |      |      |      |      |      |      |      |       |      |
| Contact Unmating Force             |                   | 3    |      |   |      |      |         |      |      |      |      |      |      |      |      |      |      |      |       |      |
| Crimp Tensile Strength             | 2                 |      |      |   |      |      |         |      |      |      |      |      |      |      |      |      |      |      |       |      |
| Durability                         |                   |      |      |   |      |      |         | 5    |      |      |      |      |      |      |      |      |      |      |       |      |
| Housing Panel Retention Force      |                   |      | 2    |   |      |      |         |      |      |      |      |      |      |      |      |      |      |      |       |      |
| Housing Locking Strength           |                   |      | 3    |   |      |      |         |      |      |      |      |      |      |      |      |      |      |      |       |      |
| Post Retention Force               |                   |      |      |   |      |      |         |      |      |      |      |      |      |      |      | 2    |      |      |       |      |
| Solderability                      |                   |      |      |   |      |      |         |      |      |      |      |      |      |      |      |      | 2    |      |       |      |
| Ammonia                            |                   |      |      |   |      |      |         |      |      |      |      |      |      |      | 3    |      |      |      |       |      |
| Humidity-Temperature Cycling       |                   |      |      |   |      |      |         |      |      | 3    |      |      |      |      |      |      |      |      |       | 4    |
| Hydrogen Sulfide                   |                   |      |      |   |      |      |         |      |      |      |      |      |      | 3    |      |      |      |      |       |      |
| Resistance to Soldering Heat       |                   |      |      |   |      |      |         |      |      |      |      |      |      |      |      |      |      |      | 2     |      |
| Thermal Shock                      |                   |      |      |   |      |      |         |      | 3    |      |      |      |      |      |      |      |      |      |       |      |
| Salt Spray                         |                   |      |      |   |      |      |         |      |      |      | 3    |      |      |      |      |      |      |      |       |      |
| Resistance to Cold                 |                   |      |      |   |      |      |         |      |      |      |      |      |      |      |      |      |      |      |       |      |
| Contact Retention Force            |                   |      |      |   |      |      |         |      |      |      |      |      | 3    |      |      |      |      |      |       |      |
| Temperature Life                   |                   |      |      |   |      |      |         |      |      |      |      | 3    |      |      |      |      |      |      |       | 5    |
| Random Vibration                   |                   |      |      |   |      |      |         |      |      |      |      |      |      |      |      |      |      |      |       | 6    |

Figure 9



**NOTE**

- (a) See paragraph 4.2.
- (b) Numbers indicate sequence in which tests are performed.
- (c) Perform test group on all contacts except part number 2232901-2 and 177917-3.
- (d) Perform test group only on contact part numbers 2232901-2 and 177917-3.

#### 4. QUALITY ASSURANCE PROVISIONS

##### 4.1. Test Conditions

Unless otherwise specified, all the tests shall be performed in any combination of the following test conditions shown in Figure 10.

|                      |                  |
|----------------------|------------------|
| Temperature          | 15°C – 35°C      |
| Relative Humidity    | 45% – 75%        |
| Atmospheric Pressure | 86.6 – 106.6 kPa |

**Figure 10**

##### 4.2. Qualification Testing

###### A. Specimen Selection

Specimens shall be prepared in accordance with applicable instruction sheets and shall be selected at random from current production. The wires used for crimping samples for qualification testing shall conform to the requirements specified in Figure 11.

| Wire Size (AWG [mm <sup>2</sup> ]) | Diameter of a Conductor (mm) | Number of Conductors | Insulation Outer Diameter (mm) |
|------------------------------------|------------------------------|----------------------|--------------------------------|
| 26 [0.14]                          | 0.16                         | 7                    | 1.30                           |
| 24 [0.22]                          | 0.16                         | 11                   | 1.5                            |
| 22 [0.31]                          | 0.18                         | 12                   | 2.0                            |
| 20 [0.51]                          | 0.18                         | 20                   | 2.6                            |
| 18 [0.76]                          | 0.18                         | 30                   | 2.8                            |
| 16 [1.27]                          | 0.18                         | 50                   | 3.1                            |

**Figure 11**

###### B. Test Sequence

Qualification inspection shall be verified by testing specimens as specified in Figure 9.

##### 4.3. Requalification Testing

If changes significantly affecting form, fit or function are made to the product or manufacturing process, product assurance shall coordinate requalification testing, consisting of all or part of the original testing sequence as determined by development/product, quality and reliability engineering.

##### 4.4. Acceptance

Acceptance is based on verification that the product meets the requirements in Figure 1. Failures attributed to equipment, test setup or operator deficiencies shall not disqualify the product. If product failure occurs, corrective action shall be taken and specimens resubmitted for qualification. Testing to confirm corrective action is required before resubmittal.

##### 4.5. Quality Conformance Inspection

The applicable quality inspection plan shall specify the sampling acceptable quality level to be used. Dimensional and functional requirements shall be in accordance with the applicable product drawing and this specification.