

System Motor Driver IC Series for CD / DVD Players

5ch System Motor Driver IC

BA5984FP, BA5956FM, BA5814FM, BA5968FP



● Description

BA5984FP/BA5956FM/BA5814FM/BA5968FP are 5-channel drivers developed for CD/DVD players. 4-channel drivers required for play back and 1-channel loading driver are incorporated into a single chip to reduce space in sets.

● Features

Parameter	BA5984FP	BA5956FM	BA5814FM	BA5968FP
Wide dynamic range	6.0V(V _{CC} =8V, R _L =8Ω)	4.0V(V _{CC} =5V, R _L =8Ω)	6.0V(V _{CC} =8V, R _L =8Ω)	6.0V(V _{CC} =8V, R _L =8Ω)
Interface amplifier	✓ (1ch~4ch)	✓ (1ch~4ch)	—	✓ (3ch~4ch)
Driver output MUTE	✓ (1ch~4ch)	✓ (1ch~4ch)	✓ (1ch,4ch,5ch/3ch)	✓ (1ch~4ch)
Regulator for microcontroller DSP	—	—	Trimmer regulator 2ch (PNP Tr is needed outside)	—
UVLO	✓	✓	✓	✓
Input error protection	✓	✓	✓	✓
Temperature protection	✓	✓	✓	✓

● Absolute maximum ratings (Ta=25°C)

Parameter	BA5984FP	BA5956FM	BA5814FM	BA5968FP	Conditions
Supply Voltage	13.5	18	13.5	13.5	V
Power dissipation	1.7 *1	2.2 *2	2.2 *3	1.7 *1	W
Operating temperature	-40 ~ +85	-35 ~ +85	-40 ~ +85	-40 ~ +85	°C
Storage temperature	-55 ~ +150	-55 ~ +150	-55 ~ +150	-55 ~ +150	°C

*1 HSOP-28 package

*2 HSOP-M36 package

*3 HSOP-M28 package

● Recommended operating conditions

Parameter	BA5984FP	BA5956FM	BA5814FM	BA5968FP	Conditions
Supply Voltage	4.3 ~ 13.2	4.5 ~ 14	4.3 ~ 13.2	4.3 ~ 9	V

● Applications

CD, DVD, MD and Car CD players.

● Electrical characteristics

○BA5984FP(Unless otherwise note, Ta=25°C, Vcc=8V, BIAS=2.5V, RL=8Ω)

Parameter	Symbol	Limits			Unit	Conditions
		Min.	Typ.	Max.		
Quiescent current	I _{CC}	—	24	34	mA	RL=no load
< BTL driver >						
Output offset voltage	V _{OO}	-100	0	+100	mV	
Max. output voltage	V _{OM}	5.4	6.0	—	V	
Closed loop voltage gain	G _{VC}	14.0	16.1	18.0	dB	
Mute on voltage	V _{MTON}	—	—	0.5	V	
Mute off voltage	V _{MTOFF}	1.5	—	—	V	
Input current for Mute pin	I _{MUTE}	—	180	270	μA	V _{MUTE} =5V
Input current for Bias pin	I _{BIAS}	—	75	120	μA	V _{BIAS} =2.5V
< OP-AMP >						
Common mode input voltage range	V _{ICM}	0.5	—	6.8	V	
Input offset voltage	V _{OFOP}	-6	0	+6	mV	
Input bias current	I _{BOP}	—	—	300	nA	
High-level output voltage	V _{OHO}	7.5	—	—	V	
Low-level output voltage	V _{OLO}	—	—	0.5	V	
Output sink current	I _{SIN}	1	—	—	mA	Pull up to Pre Vcc by 50Ω
Output source current	I _{SOU}	1	—	—	mA	Pull down to GND by 50Ω
Slew rate	S _{ROP}	—	1	—	V/us	Input pulse 100kHz, 2Vp-p
< Loading driver >						
Output saturation voltage 1	V _{SAT1}	0.7	1.1	1.6	V	Upper+Lower saturation,IL=200mA
Output saturation voltage between F&R	ΔV _{SAT1}	—	—	0.1	V	Output saturation voltage 1 between FWD and REV
Output saturation voltage 2	V _{SAT2}	1.0	1.55	2.3	V	Upper+Lower saturation,IL=500mA
< Loading driver input logic >						
Input-high level voltage	V _{IHLD}	1.5	—	V _{CC}	V	
Input-low level voltage	V _{ILLD}	-0.3	—	+0.5	V	
Input-high level current	I _{IHLD}	—	180	270	μA	V _{FWD} =V _{REV} =5V

• This product is not designed as protection against radioactive radiation.

○BA5956FM(Unless otherwise note, Ta=25°C, PreVcc=PowVcc3=12V, PowVcc1=PowVcc2=5V, BIAS=1.65V, RL=8Ω, Rd=0.5Ω, C=100pF)

Parameter	Symbol	Limits			Unit	Conditions
		Min.	Typ.	Max.		
Quiescent current	I _Q	—	34	44	mA	
Voltage for mute ON	V _{MON}	0	—	0.5	V	
Voltage for mute OFF	V _{MOFF}	2.0	—	—	V	
< Actuator driver >						
Output offset current	I _{OOF}	-9	0	+9	mA	
Maximum output voltage	V _{OM}	3.6	4.0	—	V	V _{IN} =±1.65V
Trans conductance	G _{VC}	1.5	1.8	2.1	A/V	V _{IN} =BIAS±0.2V
< Sled motor driver >						
Common mode input range	V _{ICM}	0.5	—	10.5	V	
Input bias current	I _{BOP}	—	—	300	nA	
Low level output voltage	V _{OLO}	—	0.2	0.5	V	
Output source current	I _{SO}	0.5	—	—	mA	
Output sink current	I _{SI}	0.5	—	—	mA	
Output offset voltage	V _{OOF}	-50	0	+50	mV	
Maximum output voltage	V _{OMSL}	8.0	9.5	—	V	V _{IN} =±1.65V
Closed loop voltage gain	G _{VSL}	17.6	19.6	21.6	dB	V _{IN} =±0.2V
< Loading motor driver >						
Output offset voltage	V _{OOF}	-50	0	+50	mV	
Maximum output voltage	V _{OMLD}	3.5	4.0	—	V	V _{IN} =±1.65V
Voltage gain	G _{VLD}	15.7	17.7	19.7	dB	V _{IN} =BIAS±0.2V
< Spindle motor driver>						
Output offset voltage	V _{OOF}	-50	0	+50	mV	
Maximum output voltage	V _{OMS}	8.0	9.5	—	V	V _{IN} =±1.65V
Voltage gain	G _{VSP}	15.7	17.7	19.7	dB	V _{IN} =BIAS±0.2V

• This product is not designed as protection against radioactive radiation.

● Electrical characteristic

○BA5814FM (Unless otherwise note, Ta=25°C, Vcc=8V, PVcc45=5V, BIAS=2.5V, RL=8Ω)

Parameter	Symbol	Limits			Unit	Conditions
		Min.	Typ.	Max.		
Quiescent current	Icc	—	20	30	mA	RL=no load
< BTL Driver >						
Output offset voltage	VOOF	-50	0	+50	mV	
High level output voltage 1	VOM1	5.4	6.0	—	V	ch1, 2, 3
High level output voltage 2	VOM2	3.6	4.0	—	V	ch4, 5
Closed loop voltage gain 1	Gvc1	9.5	12.0	14.5	dB	ch1 RIN=10kΩ
Closed loop voltage gain 2	Gvc2	15.5	18.0	20.5	dB	ch2 RIN=10kΩ
Closed loop voltage gain 3	Gvc3	16.5	18.0	19.5	dB	ch3, 4, 5
Mute on voltage	VMTON	—	—	0.5	V	
Mute off voltage	VMTOFF	2.0	—	—	V	
Input current for mute pin	IMUTE	—	90	140	μA	VMUTE=5V
Input current for bias pin	IBIAS	—	75	120	μA	
< Regulator >						
Threshold voltage of RE_I pin	VREITH	1.14	1.2	1.26	V	
Output sink current of RE_O pin	ISIN	10	50	—	mA	
Input bias current of RE_I pin	IBOP	—	20	300	nA	

• This product is not designed to protect against radioactive rays.

○BA5968FP (Unless otherwise note, Ta=25°C, Vcc=8V, BIAS=2.5V, RL=8Ω)

Parameter	Symbol	Limits			Unit	Conditions
		Min.	Typ.	Max.		
Quiescent current	Icc	—	24	34	mA	RL=no load
< BTL driver >						
Output offset voltage	Voo	-50	0	+50	mV	
Max. output voltage	VOM	5.4	6.0	—	V	
Closed loop voltage gain	Gvc	14.0	16.1	18.0	dB	
Mute on voltage	VMTON	—	—	0.5	V	
Mute off voltage	VMTOFF	1.5	—	—	V	
Input current for Mute pin	IMUTE	—	180	270	μA	VMUTE=5V
Bias mute on voltage	VBMUTE	—	—	0.5	V	
Bias mute off voltage		1.1	—	—	V	
Input current for Bias pin	IBIAS	—	75	120	μA	VBIAS=2.5V
< Op-amp >						
Common mode input voltage range	VICM	0.5	—	6.8	V	
Input offset voltage	VOFOP	-6	0	+6	mV	
Input bias current	IBOP	—	—	300	nA	
High level output voltage	VOHOP	7.5	—	—	V	
Low level output voltage	VOLOP	—	—	0.5	V	
Output sink current	ISIN	1	—	—	mA	Pull up to Pre Vcc by 50Ω
Output source current	ISOU	1	—	—	mA	Pull down to GND by 50Ω
Slew rate	SROP	—	1	—	V/us	Input pulse 100kHz,2Vp-p
< Loading driver >						
Output saturation voltage 1	VSAT1	0.6	0.9	1.4	V	Sum of Upper+Lower voltage,IL=200mA
Output saturation voltage between F&R	ΔVSAT1	—	—	0.1	V	Output saturation voltage 1 between FWD and REV
Output saturation voltage 2	VSAT2	0.7	1.2	2.0	V	Sum of Upper+Lower voltage,IL=500mA
Output gain	LGVC	6.6	8.6	10.6	dB	VOLD/VLDCTL
< Loading driver input logic >						
Input high level voltage	VIHLD	1.5	—	Vcc	V	
Input low level voltage	VILLD	-0.3	—	+0.5	V	
Input high level current	IIHLD	—	180	270	μA	VFWD=VREV=5V

• This product is not designed to protect against radioactive rays.

● Characteristic reference data

○ BA5984FP

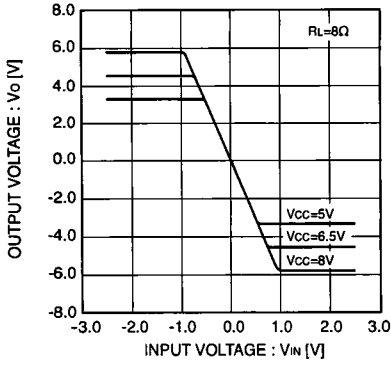

Fig. 1
Supply fluctuation I/O characteristic
(Ta = -40°C)

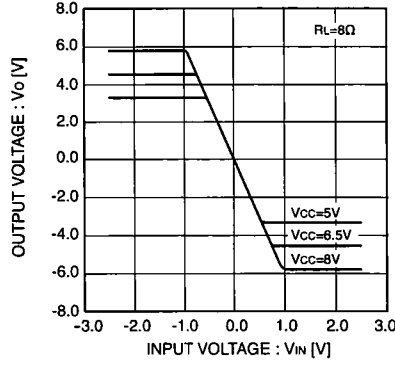

Fig. 2
Supply fluctuation I/O characteristic
(Ta = 25°C)

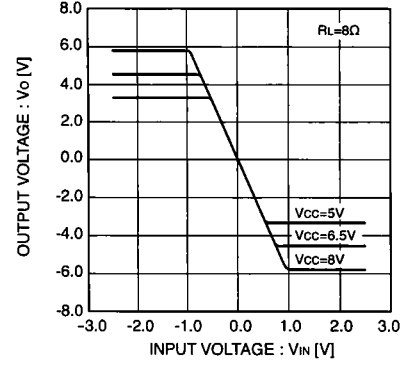

Fig. 3
Supply fluctuation I/O characteristic
(Ta = 85°C)

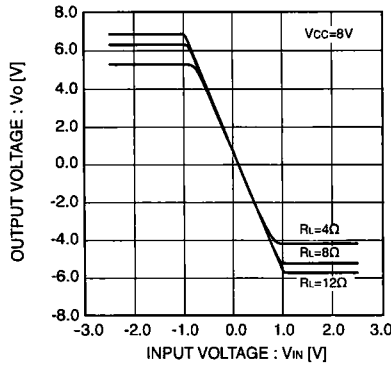

Fig. 4
Load fluctuation I/O characteristic
(Ta = -40°C)

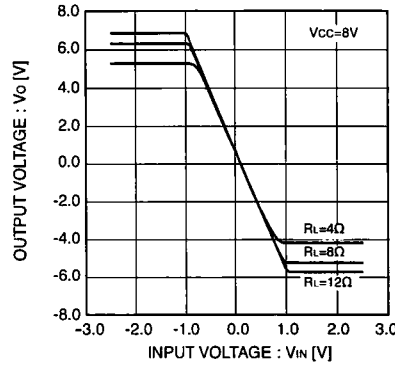

Fig. 5
Load fluctuation I/O characteristic
(Ta = 25°C)

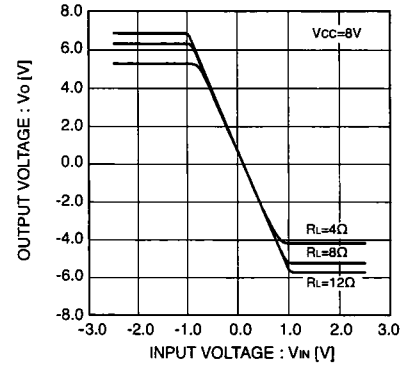

Fig. 6
Load fluctuation I/O characteristic
(Ta = 85°C)

○ BA5956FM

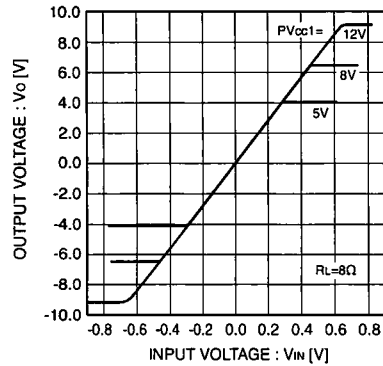

Fig. 7
Supply fluctuation I/O characteristic
(Ta = -35°C)

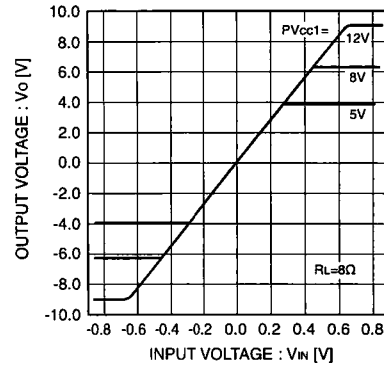

Fig. 8
Supply fluctuation I/O characteristic
(Ta = 25°C)

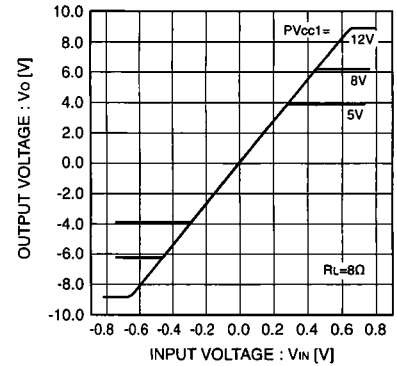

Fig. 9
Supply fluctuation I/O characteristic
(Ta = 85°C)

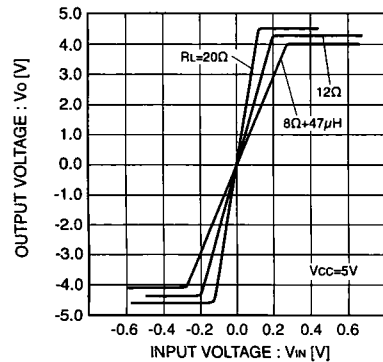

Fig. 10
Load fluctuation I/O characteristic
(Ta = -35°C)

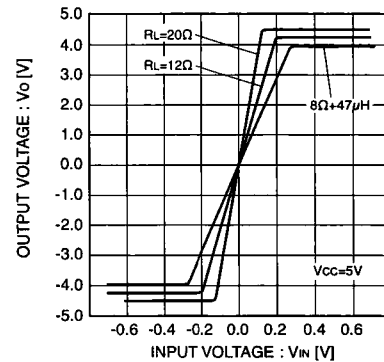

Fig. 11
Load fluctuation I/O characteristic
(Ta = 25°C)

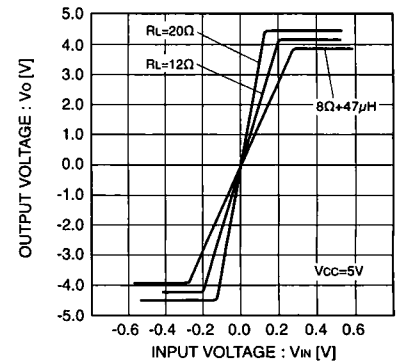

Fig. 12
Load fluctuation I/O characteristic
(Ta = 85°C)

(*)The data above is ability value of sample, and is not guaranteed.

● Characteristic reference data

○ BA5814FM

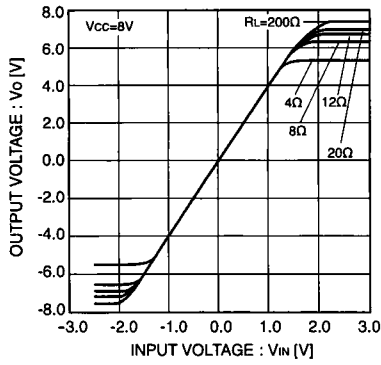

Fig.13
Load fluctuation I/O characteristic ch1
($T_a = -40^\circ\text{C}$)

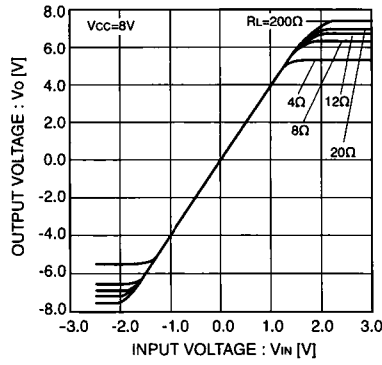

Fig.14
Load fluctuation I/O characteristic ch1
($T_a = 25^\circ\text{C}$)

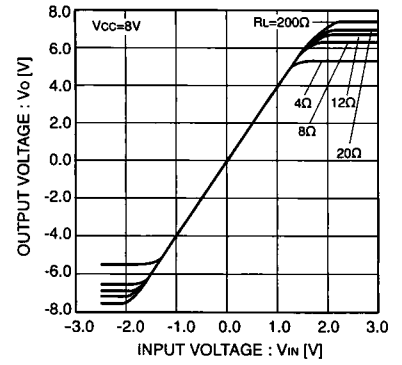

Fig.15
Load fluctuation I/O characteristic ch1
($T_a = 85^\circ\text{C}$)

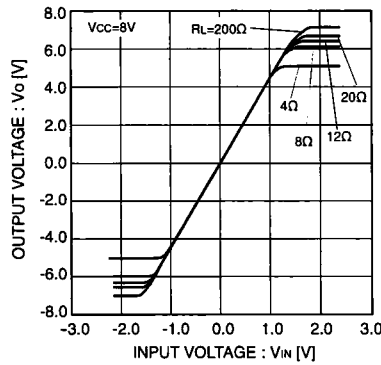

Fig.16
Load fluctuation I/O characteristic ch2
($T_a = -40^\circ\text{C}$)

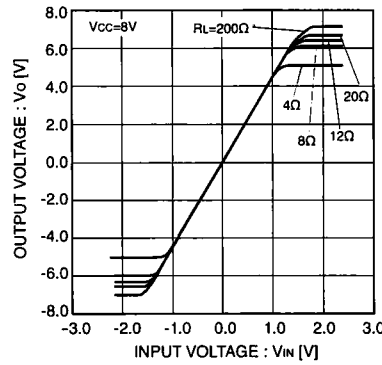

Fig.17
Load fluctuation I/O characteristic ch2
($T_a = 25^\circ\text{C}$)

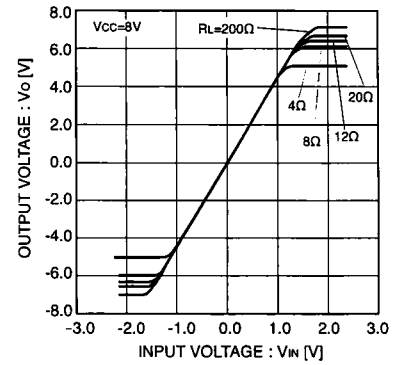

Fig.18
Load fluctuation I/O characteristic ch2
($T_a = 85^\circ\text{C}$)

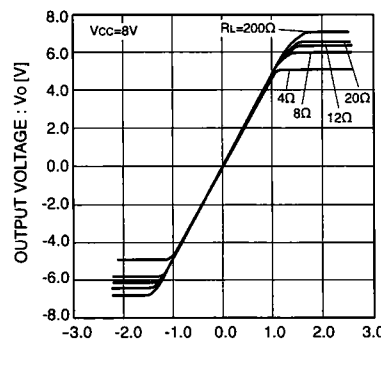

Fig.19
Load fluctuation I/O characteristic ch3
($T_a = -40^\circ\text{C}$)

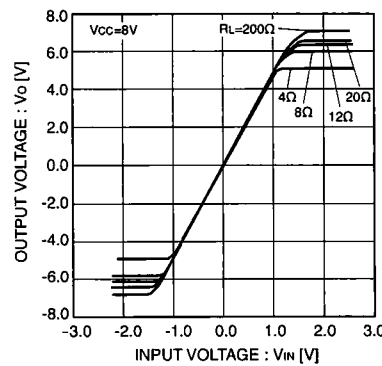

Fig.20
Load fluctuation I/O characteristic ch3
($T_a = 25^\circ\text{C}$)

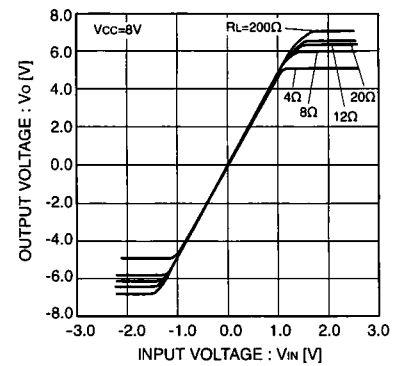

Fig.21
Load fluctuation I/O characteristic ch3
($T_a = 85^\circ\text{C}$)

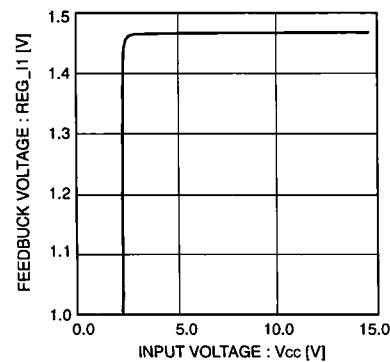

Fig.22
Regulator1 terminal supply
voltage characteristic
($T_a = -40^\circ\text{C}$)

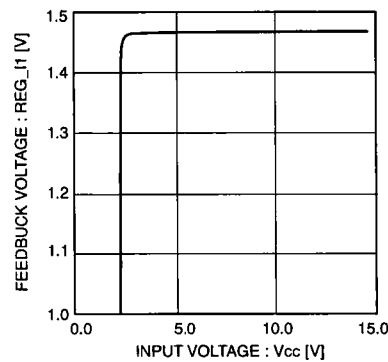

Fig.23
Regulator1 terminal supply
voltage characteristic
($T_a = 25^\circ\text{C}$)

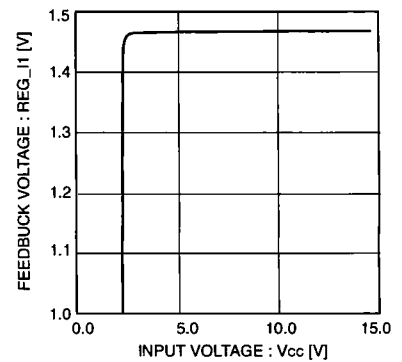

Fig.24
Regulator1 terminal supply
voltage characteristic
($T_a = 85^\circ\text{C}$)

● Characteristic reference data

○BA5968FP

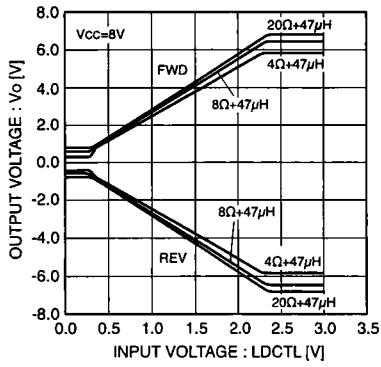

Fig.25
I/O characteristic (Loading driver)
($T_a = -40^\circ\text{C}$)

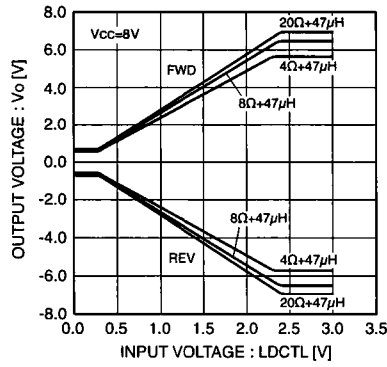

Fig.26
I/O characteristic (Loading driver)
($T_a = 25^\circ\text{C}$)

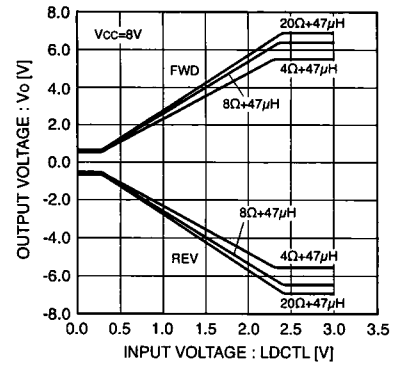

Fig.27
I/O characteristic (Loading driver)
($T_a = 85^\circ\text{C}$)

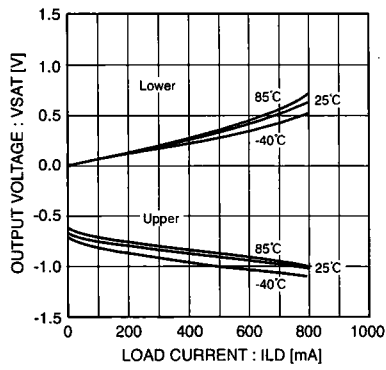

Fig.28
Load fluctuation temperature
characteristic (Loading driver)
($V_{cc} = 6.5\text{V}$)

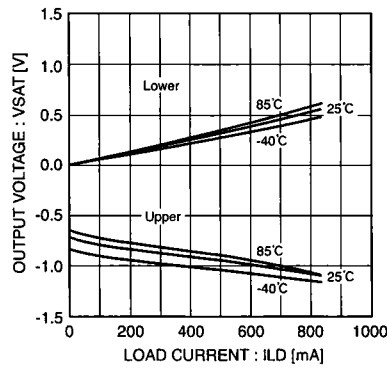

Fig.29
Load fluctuation temperature
characteristic (Loading driver)
($V_{cc} = 7.5\text{V}$)

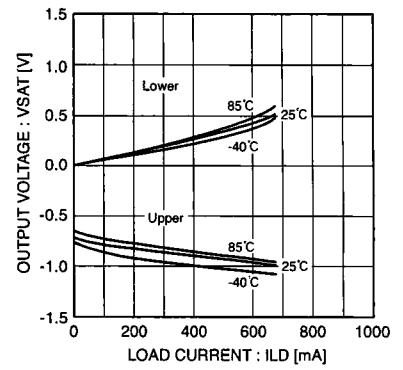
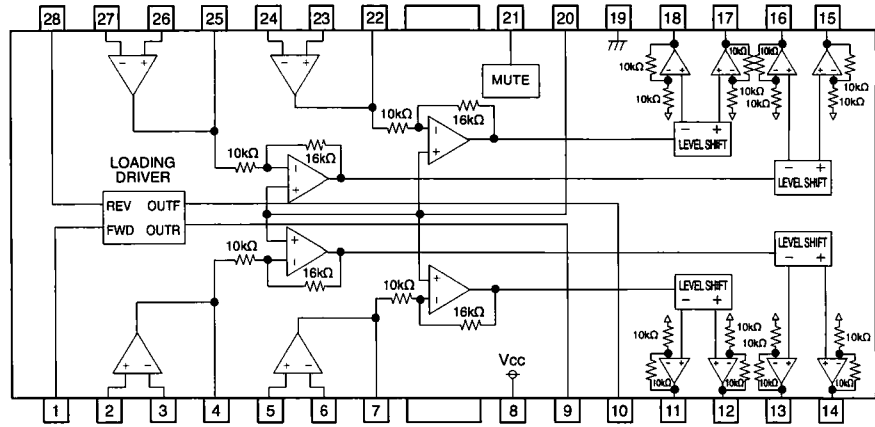

Fig.30
Load fluctuation temperature
characteristic (Loading driver)
($V_{cc} = 8\text{V}$)

● Block diagram

○BA5984FP



Pin No.	Pin name	Function
1	FWD	Input for loading forward
2	OPIN1(+)	Non inverted input of CH1 OP-AMP
3	OPIN1(-)	Inverted input of CH1 OP-AMP
4	OPOUT1	Output of CH1 OP-AMP
5	OPIN2(+)	Non inverted input of CH2 OP-AMP
6	OPIN2(-)	Inverted input of CH2 OP-AMP
7	OPOUT2	Output of CH2 OP-AMP
8	Vcc	Vcc
9	VOL(-)	Inverted output of loading
10	VOL(+)	Non inverted output of loading
11	VO2(-)	Inverted output of CH2
12	VO2(+)	Non inverted output of CH2
13	VO1(-)	Inverted output of CH1
14	VO1(+)	Non inverted output of CH1

Pin No.	Pin name	Function
15	VO4(+)	Non inverted output of CH4
16	VO4(-)	Inverted output of CH4
17	VO3(+)	Non inverted output of CH3
18	VO3(-)	Inverted output of CH3
19	GND	Substrate ground
20	BIAS	Input for Bias-amplifier
21	MUTE	Input for mute control
22	OPOUT3	Output for CH3 OP-AMP
23	OPIN3(-)	Inverting input for CH3 OP-AMP
24	OPIN3(+)	Non inverting input for CH3 OP-AMP
25	OPOUT4	Output for CH4 OP-AMP
26	OPIN4(-)	Inverting input for CH4 OP-AMP
27	OPIN4(+)	Non inverting input for CH4 OP-AMP
28	REV	Input for loading reverse

notes : Symbol of + and - (output of drivers) refers to polarity to input pin.
(For example if voltage of pin4 high, pin14 is high.)

○BA5956FM

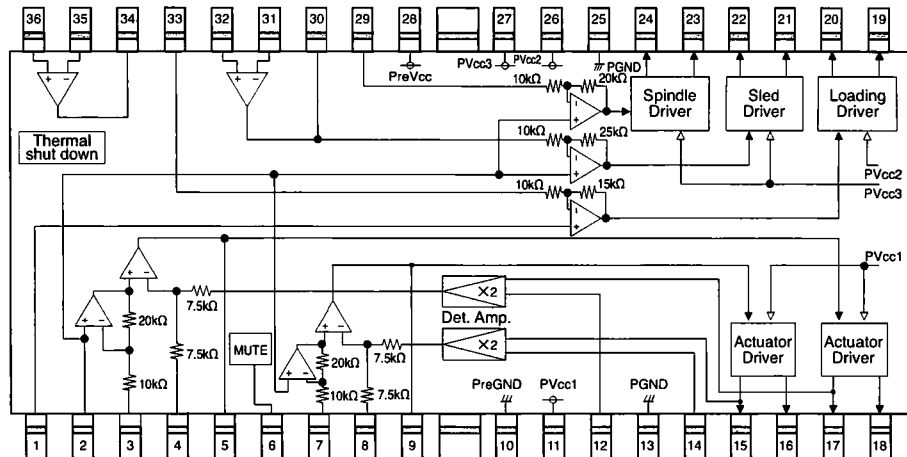

Pin No.	Pin name	Function
1	LDBIAS	Input for bias voltage (Loading driver)
2	BIAS	Input for bias voltage
3	FCIN	Input for focus driver
4	CFCerr1	Connection with capacitor for error amplifier 1
5	CFCerr2	Connection with capacitor for error amplifier 2
6	MUTE	Input for mute control
7	TKIN	Input for tracking driver
8	CTKerr1	Connection with capacitor for error amplifier 1
9	CTKerr2	Connection with capacitor for error amplifier 2
10	PreGND	GND for pre-drive block
11	PVcc1	Vcc for power block of actuator
12	VNFFC	Feedback for focus driver
13	PGND1	GND for power block of actuator
14	VNFTK	Feedback for tracking driver
15	VOTK(-)	Inverted output of tracking
16	VOTK(+)	Non inverted output of tracking
17	VOFC(-)	Inverted output of focus
18	VOFC(+)	Non inverted output of focus

Pin No.	Pin name	Function
19	VOLD(-)	Inverted output of loading
20	VOLD(+)	Non inverted output of loading
21	VOSL(-)	Inverted output of sled
22	VOSL(+)	Non inverted output of sled
23	VOSP(-)	Inverted output of spindle
24	VOSP(+)	Non inverted output of spindle
25	PGND2	GND for power block of loading, sled and spindle driver
26	PVcc2	Vcc for power block of loading driver
27	PVcc3	Vcc for power block of sled and spindle driver
28	PreVcc	Vcc for pre-drive block
29	SPIN	Input for spindle driver
30	OPOUTSL	Sled Pre Op-amp output
31	OPINSL(-)	Sled Pre Op-amp invert input
32	OPINSL(+)	Sled Pre Op-amp non invert input
33	LDIN	Input for loading driver
34	OPOUT	Op-amp output
35	OPIN(-)	Op-amp invert input
36	OPIN(+)	Op-amp non invert input

notes : Symbol of + and - (output of drivers) refers to polarity to input pin. (For example if voltage of pin3 is high, pin18 is high.)

● Block diagram

○BA5814FM

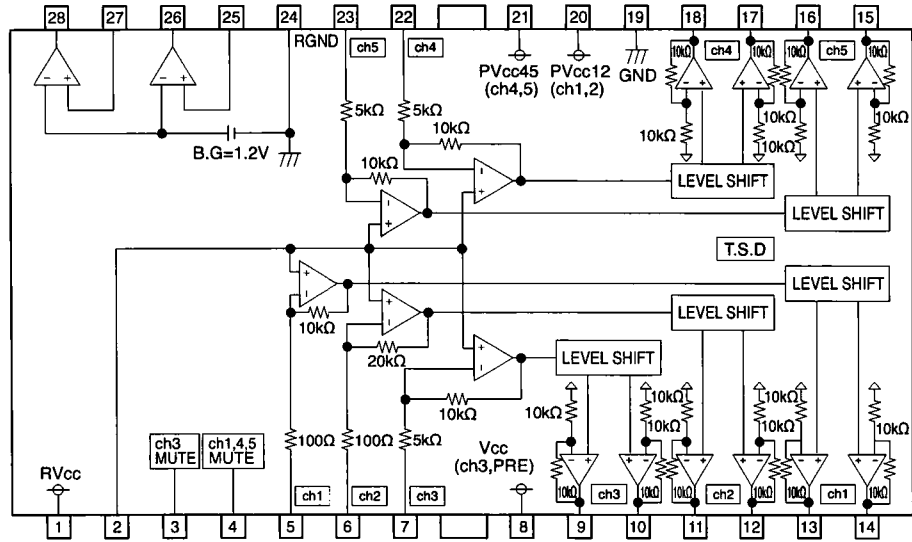

Pin No.	Symbol	Function
1	RVcc	Vcc (for REG)
2	BIAS	Input for reference voltage (bias)
3	MUTE1	CH3 Mute control
4	MUTE2	CH1,4,5 Mute control
5	Vin1	Input for CH1
6	Vin2	Input for CH2
7	Vin3	Input for CH3
8	Vcc	Vcc (for PRE,CH3 POWER)
9	VO3(-)	Inverted output of CH3
10	VO3(+)	Noninverted output of CH3
11	VO2(-)	Inverted output of CH2
12	VO2(+)	Noninverted output of CH2
13	VO1(-)	Inverted output of CH1
14	VO1(+)	Noninverted output of CH1

Pin No.	Symbol	Function
15	VO5(+)	Non inverted output of CH5
16	VO5(-)	Inverted output of CH5
17	VO4(+)	Non inverted output of CH4
18	VO4(-)	Inverted output of CH4
19	GND	GND (for PRE,POWER)
20	PVcc12	Vcc (for CH1,2 POWER)
21	PVcc45	Vcc (for CH4,5 POWER)
22	Vin4	Input for CH4
23	Vin5	Input for CH5
24	RGND	GND (for REG)
25	RE_I1	Regulator1 terminal of output feedback
26	RE_O1	Regulator1 terminal connected base of output transistor
27	RE_I2	Regulator2 terminal of output feedback
28	RE_O2	Regulator2 terminal connected base of output transistor

Notes: Symbol of+and- (output of drivers) refers to polarity of input pin. (For example if voltage of pin.10 is high, pin.9 is low)

○BA5968FP

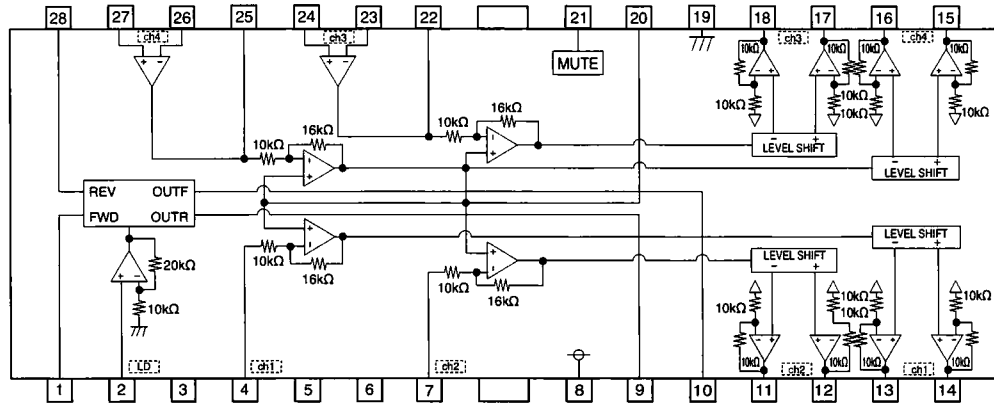

Pin No.	Symbol	Function
1	FWD	Input for loading forward
2	LDCTL	Loading driver output voltage control terminal
3	TEST	TEST
4	IN1	Input of CH1
5	TEST	TEST
6	TEST	TEST
7	IN2	Input of CH2
8	Vcc	Vcc
9	VOL(-)	Inverted output of loading
10	VOL(+)	Non inverted output of loading
11	VO2(-)	Inverted output of CH2
12	VO2(+)	Non inverted output of CH2
13	VO1(-)	Inverted output of CH1
14	VO1(+)	Non inverted output of CH1

Pin No.	Symbol	Function
15	VO4(+)	Non inverted output of CH4
16	VO4(-)	Inverted output of CH4
17	VO3(+)	Non inverted output of CH3
18	VO3(-)	inverted output of CH3
19	GND	Substrate ground
20	BIAS	Input for Bias-amplifier
21	MUTE	Input for mute control
22	OPOUT3	Output of CH3 Op-amp
23	OPIN3(-)	Inverting input of CH3 Op-amp
24	OPIN3(+)	Non inverting input for CH3 Op-amp
25	OPOUT4	Output of CH4 Op-amp
26	OPIN4(-)	Inverting input of CH4 Op-amp
27	OPIN4(+)	Non inverting input of CH4 Op-amp
28	REV	Input for loading reverse

Notes: Symbol of+and- (output of drivers) refers to polarity of input pin. (For example if voltage of pin4 high, pin14 is high)

● Application circuit

○ BA5984FP

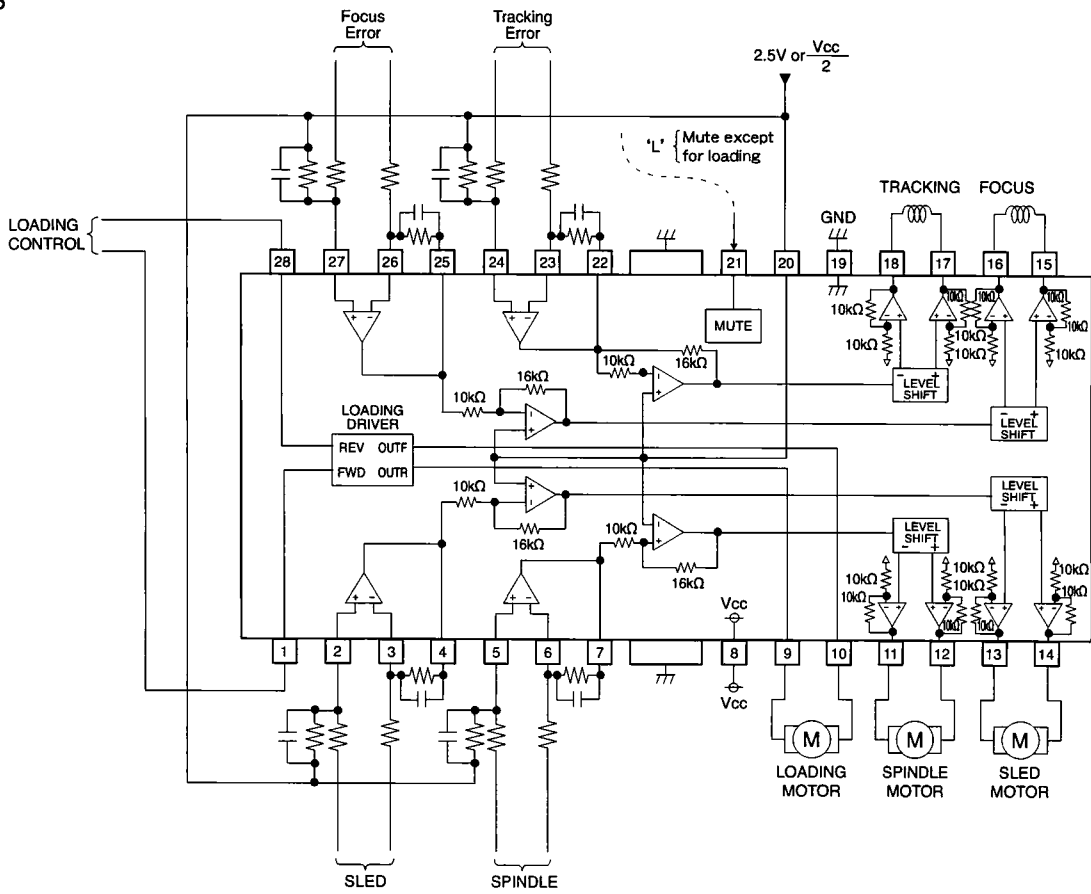

○ BA5956FM

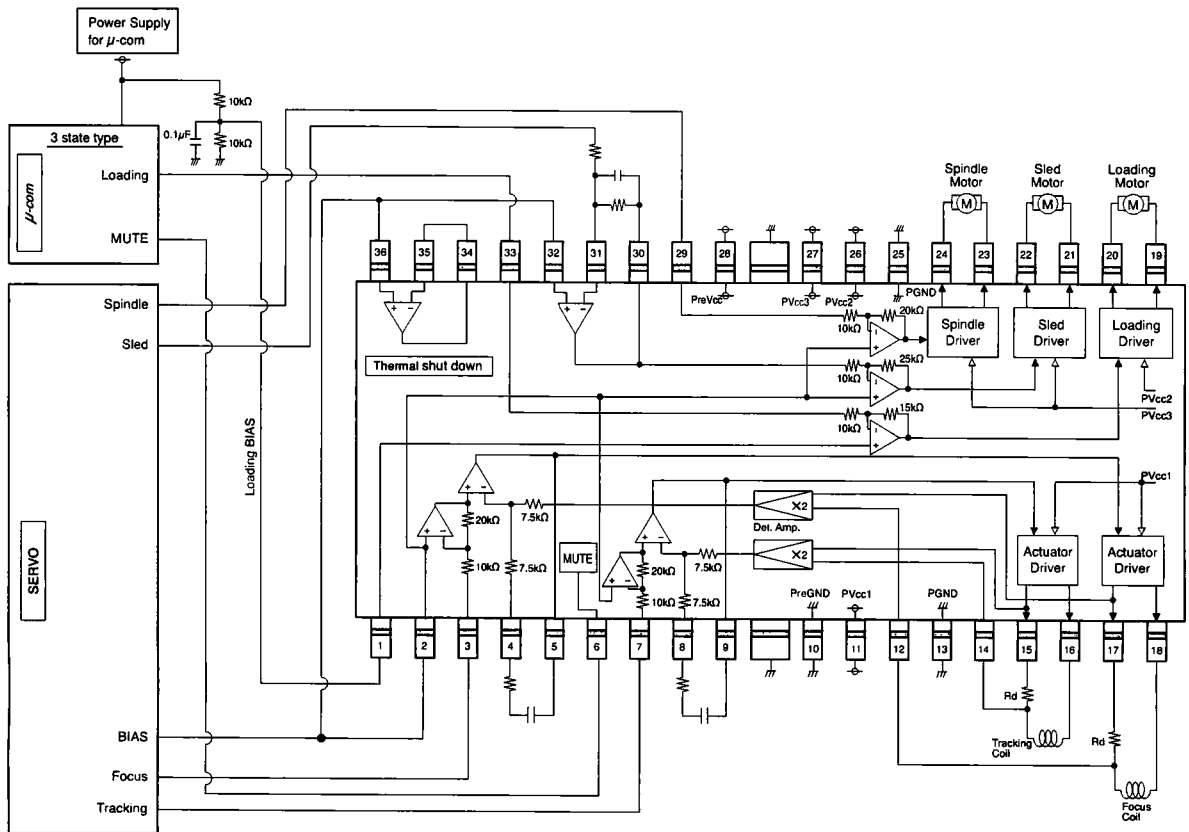

● Application circuit

○BA5814FM

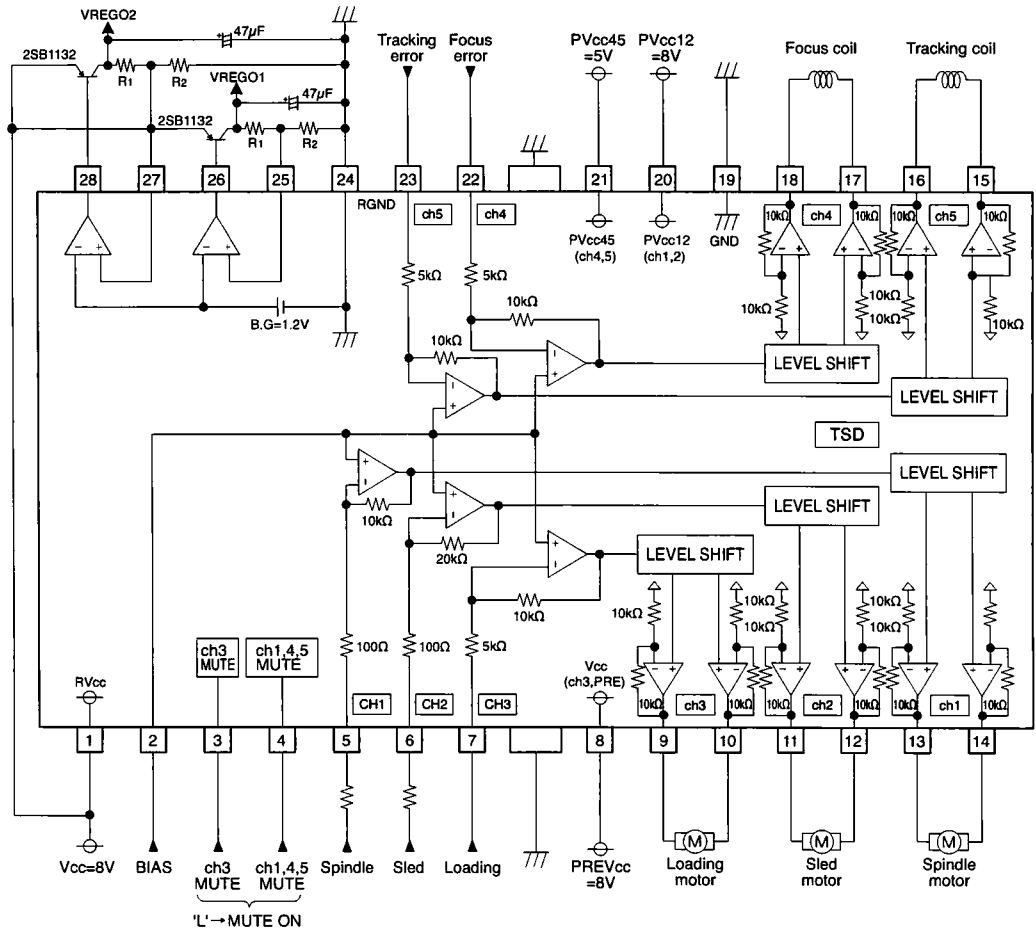

○BA5968FP

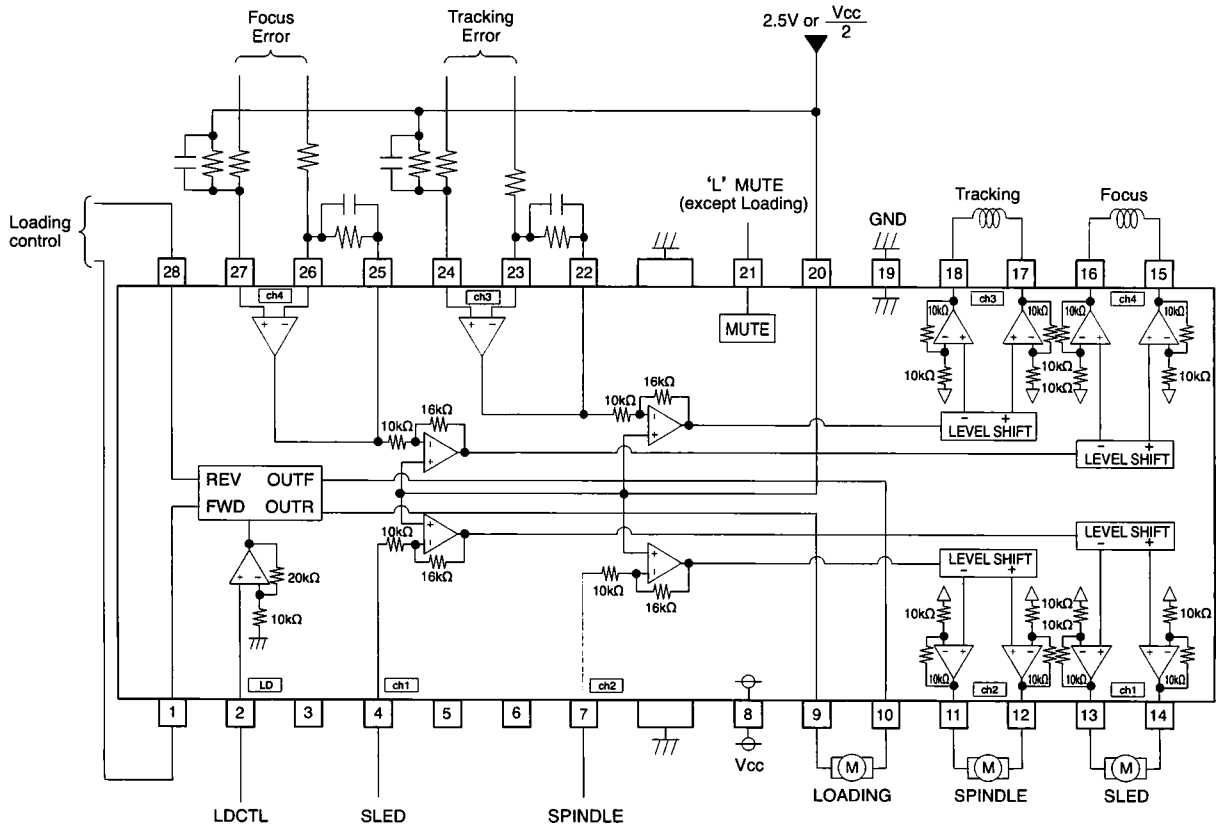

● Equivalent circuit diagram of terminals

○BA5984FP

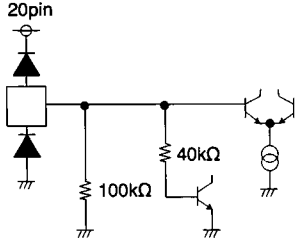
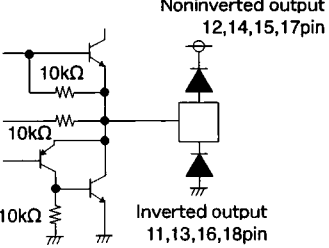
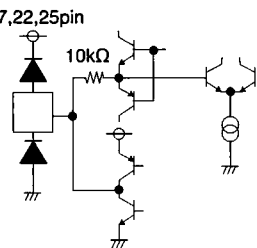
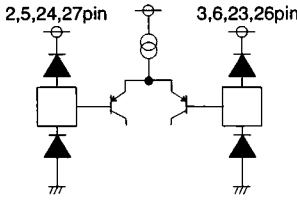
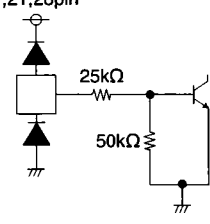
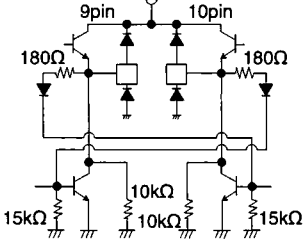
Bias	Output for BTL driver	Op-amp output for sled driver (& BTL driver input)
		
Input for Op-amp	Input for Mute • loading driver	Output for loading driver
		

○BA5956FM

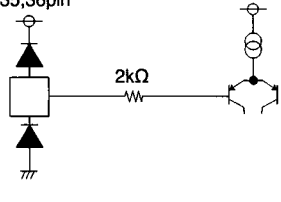
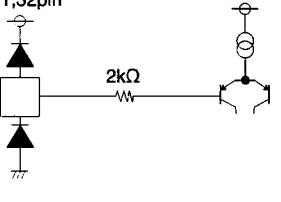
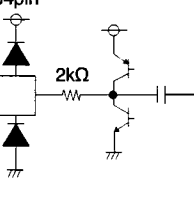
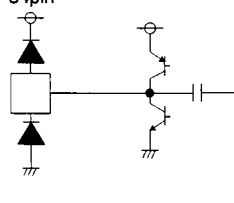
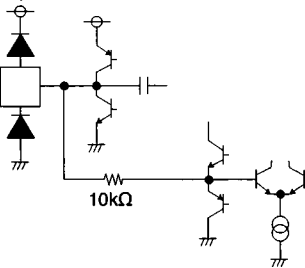
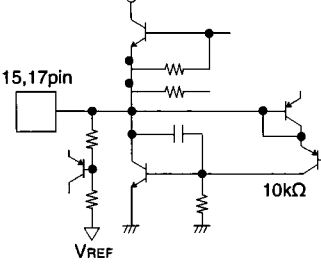
Op-amp input	Pre Op-amp input for sled driver	Driver input
		
Op-amp output	Pre Op-amp output for sled driver (& driver input)	Inverted output for focus and tracking driver
		

● Equivalent circuit diagram of terminals

○BA5814FM

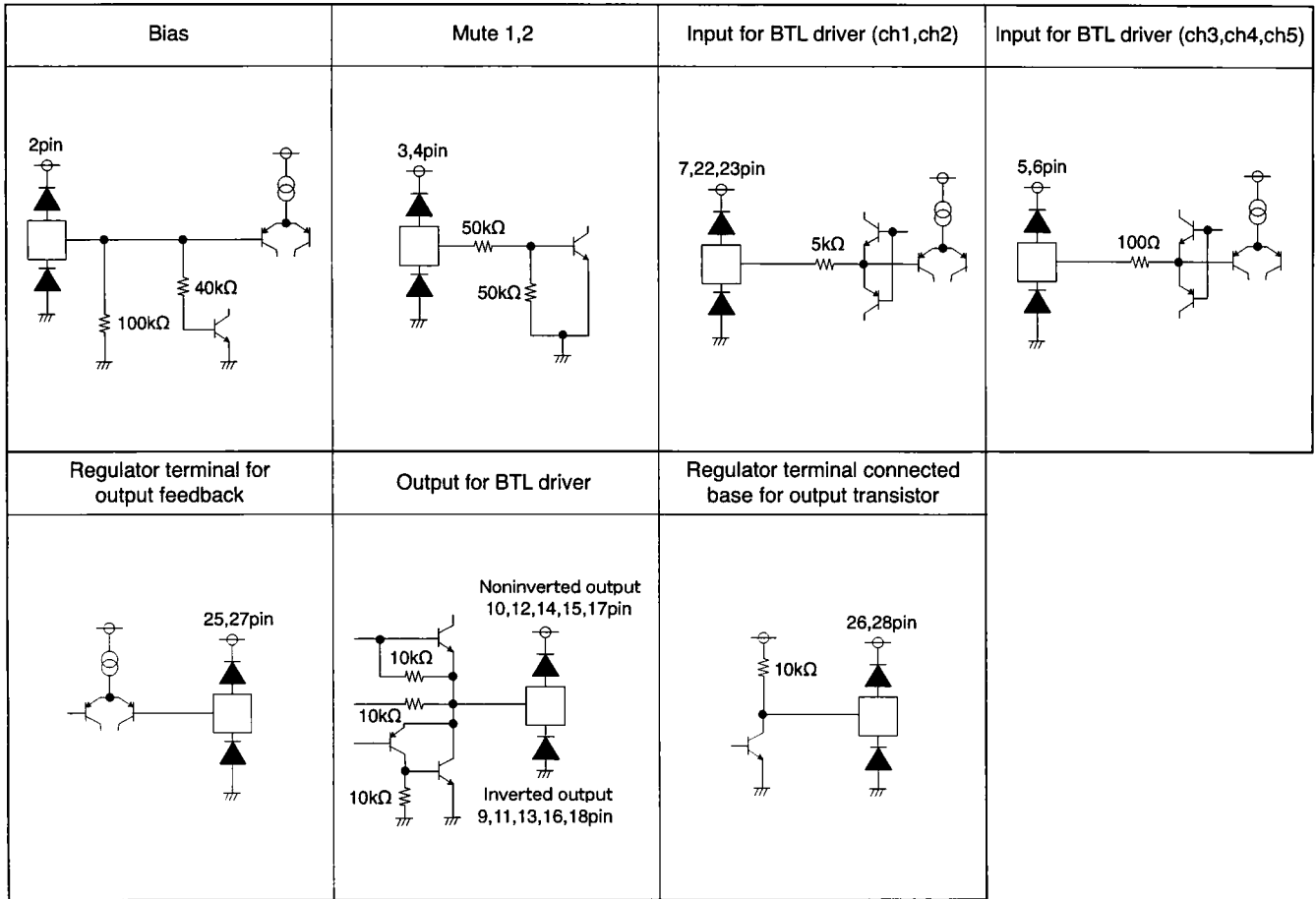

○BA5968FP

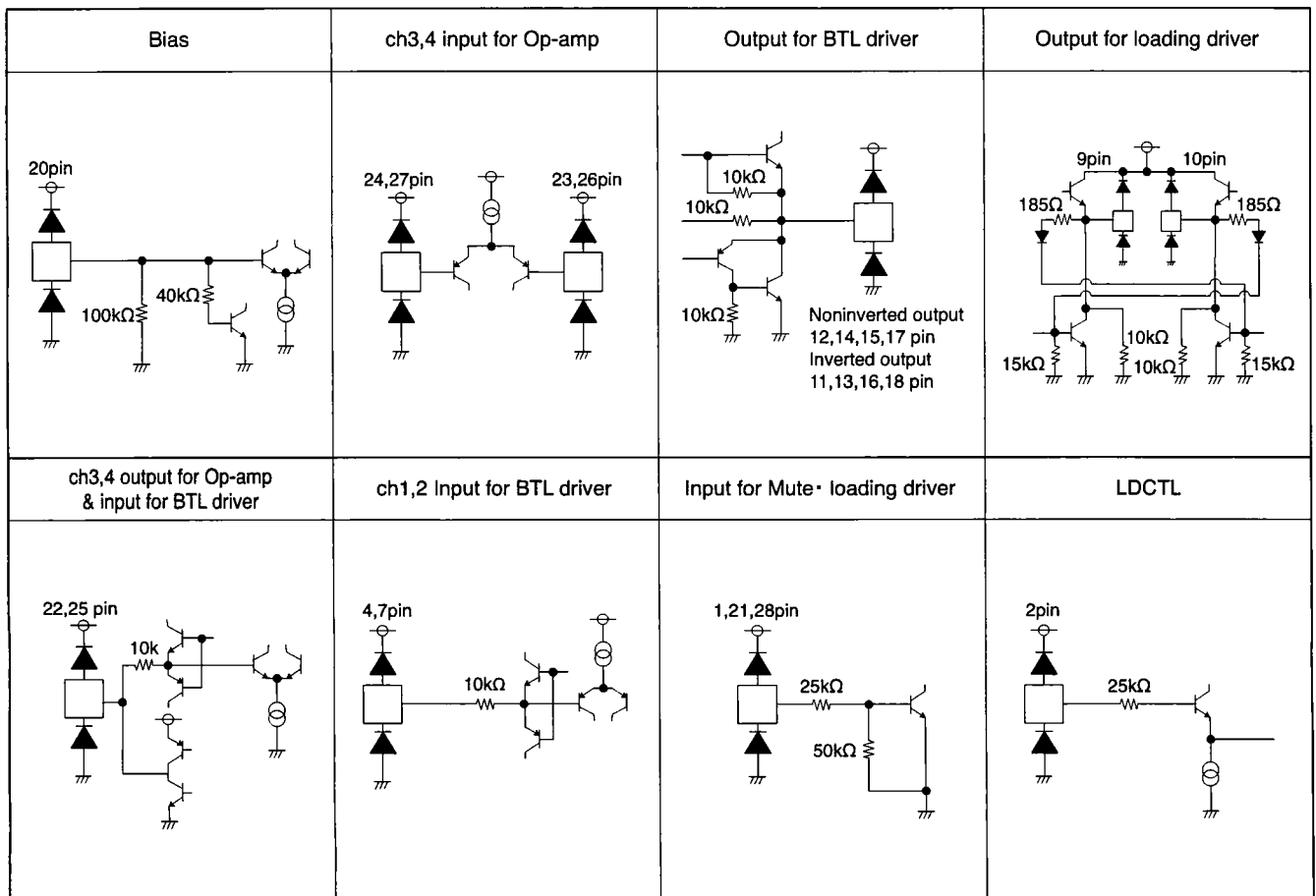

● Functional description

1) When less than 0.7V is applied to bias terminal, mute is ON. Typically, more than 1.3V is recommended.

BA5956FM	BA5968FP	BA5984FP	BA5814FM
1,2pin	20pin	20pin	2pin

2) Supply voltage descent mute circuit is incorporated.

	BA5956FM	BA5968FP	BA5984FP	BA5814FM
Mute Voltage	3.5V	3.8V	3.8V	3.7V
Reset	3.7V	4.0V	4.0V	3.9V

3) When mute terminal voltage is OPEN or lower than 0.5V, output current can be mute. Typically, the mute terminal must be higher than 1.5V.

BA5956FM	BA5968FP	BA5984FP	BA5814FM
6pin : ch1,2,4,5	21pin : ch1~ch4	21pin : ch2~ch4	3pin : ch3 4pin : ch2,4,5

○ BA5956FM

Current feedback driver

Trans conductance (output current/input voltage) is calculated as follows:

$$g_m = \frac{1}{R_d + R_{WIRE}} \text{ (A/V)}$$

$R_{WIRE} = 0.15\Omega(\pm 0.05\Omega)(\text{Typ.}): \text{Au wire.}$

○ BA5968FP, BA5984FP

Loading driver logic input

FWD (1pin)	REV (28pin)	VOL (+) (10pin)	VOL (-) (9pin)	Function
L	L	Open	Open	Open mode
L	H	L	H	Reverse mode
H	L	H	L	Forward mode
H	H	L	L	Brake mode

Input circuit of pin1 and pin28 is designed to avoid simultaneous activation of upper and lower output Tr. ; however, in order to improve reliability, apply motor forward/backward input once through open mode. It is recommended to keep open mode for more than 10msec. For BA5968FP, the voltage between the outputs can be controlled with the terminal LDCTL (pin.2). The voltage is set 2.7 times (8.6dB Typ.) LDCTL (pin.2).

○ BA5814FM

VREGO (output voltage of regulator) is output with obtaining dispersion of VREITH (threshold voltage of RE_I pin) and external resistor. VREGO is calculated by the formula below. Choose the exact external resistor with consideration of IBOP.

$$VREGO = VREITH \times \left(\frac{R_1}{R_2} + 1 \right) - R_1 \times IBOP$$

- 1) The capacitor between output of regulator (pin 6) and GND has characteristics that prevent oscillation. Use a capacitor with good temperature characteristics.
- 2) The supply voltage of the regulator (pin 1) is from the internal current source. GND of the regulator (pin 24) is also from the internal current source. If the regulators are not being utilized, connect them to an external voltage supply and GND.

● Operation Notes

1) Absolute maximum ratings

An excess in the absolute maximum ratings, such as supply voltage, temperature range of operating conditions(Topr.), etc., can break down the devices, thus making impossible to identify breaking mode, such as a short circuit or an open circuit. If any over rated values will expect to exceed the absolute maximum ratings, consider adding circuit protection devices, such as fuses.

2) Reverse polarity connection of the power supply

Connecting of power supply in reverse polarity can damage IC. Take precautions when connecting the power supply lines. An external direction diode can be added.

3) Power supply lines

The back regenerated-current is produced by counter electoromotive force of the motor, Set in bypass capacitor (0.1 μ F) close to pins between power supply and GND. It's capacitance value should be determined after careful check that any problems are not found in various characteristic. (for example, a leak capacitance of the electorolytic capacitor at low temperature.)

4) GND voltage

GND terminal potential should maintain at the minimum ground voltage level. Furthermore, no terminals should be lower than the GND potential voltage including an electric transients.

5) Thermal design

Use a thermal design that allows for a sufficient margin in light of the power dissipation (Pd) in actual operating conditions.

6) Inter-pin shorts and mounting errors

Use caution when positioning the IC for mounting on printed circuit boards. The IC may be damaged if there is any connection error or if positive and ground power supply terminals are reversed. The IC may also be damaged if pins are shorted together or are shorted to other circuit's power lines.

7) Operation in a strong electromagnetic field

Use caution when using the IC in the presence of a strong electromagnetic field as doing so may cause the IC to malfunction.

8) ASO

When using the IC, set the output transistor so that it does not exceed absolute maximum ratings or ASO.

9) Thermal shutdown circuit (TSD circuit)

When chip temperature becomes 175°C (Typ.), output current is muted, and when chip temperature becomes 150°C(Typ.), driver portion circuit gets started. The thermal shutdown circuit (TSD circuit) is designed only to shut the IC off to prevent runaway thermal operation. It is not designed to protect the IC or guarantee its operation. Do not continue to use the IC after operating this circuit or use the IC in an environment where the operation of this circuit is assumed.

10) Capacitors connected between output and ground pins

If a large capacitance value is connected between the output and ground pins, and if the VCC falls to 0 V or becomes shorted with the ground pin, the current stored in the capacitor may flow to the output pin. This can cause damage to the IC. Set capacitors connected between the output and ground pins to values smaller than 0.1 μ F.

11) Testing on application boards

When testing the IC on an application board, connecting a capacitor to a pin with low impedance subjects the IC to stress. Always discharge capacitors after each process or step. Always turn the IC's power supply off before connecting it to, or removing it from a jig or fixture, during the inspection process. Ground the IC during assembly steps as an antistatic measure. Use similar precaution when transporting and storing the IC.

12) Regarding input pin of the IC (Fig 13)

This monolithic IC contains P+ isolation and P substrate layers between adjacent elements to keep them isolated. P-N junctions are formed at the intersection of these P layers with the N layers of other elements, creating a parasitic diode or transistor. For example, the relation between each potential is as follows : When "GND > Pin A" and "GND > Pin B", the P-N junction operates as a parasitic diode. Parasitic diodes can occur inevitably in the structure of the IC. The operation of parasitic diodes can result in mutual interference among circuits, operational faults, or physical damage. Accordingly, methods by which parasitic diodes operate, such as applying a voltage that is lower than the GND (P substrate) voltage to an input pin, should not be used. Please do not apply the voltage to the input terminal when the power-supply voltage is not impressed. Moreover, please impress each input terminal lower than the power-supply voltage or equal to the specified range in the guaranteed voltage when the power-supply voltage is impressing.

13) Ground wiring patterns

Use separate ground lines for control signals and high current power driver outputs. Because these high current outputs that flows to the wire impedance changes the GND voltage for control signal. Therefore, each ground terminal of IC must be connected at the one point on the set circuit board. As for GND of external parts, it is similar to the above- mentioned.

14) Output of all drivers is muted by thermal shutdown and reduction of supply voltage and output of BTL driver except for loading driver is muted by mute terminal ON and reduction of bias terminal voltage. For pre-op-amp, it's not muted in any case. Output terminal of BTL driver at mute mode is internal bias voltage ((Vcc-0.7)/2V).

15) Vcc of pre portion supply voltage same as Vcc of power portion or higher.

16) Between supply power sources, attach bypass capacitor (around 0.1 μ F) to the root of this IC.

17) Set GND of IC to minimum electrical potential among pin voltage.

18) Heat dissipation fan is connected to GND in package. Connect it to external GND.

● Order product name selection

B A 5 9 8 4 F P - E 2

ROHM product name

Part No.

Package HSOP28

Taping name
Reel embossed carrier tape(HSOP28)

B A 5 9 5 6 F M - E 2

ROHM product name

Part No.

Package HSOP-M36

Taping name
Reel embossed carrier tape(HSOP-M36)

B A 5 8 1 4 F M - E 2

ROHM product name

Part No.

Package HSOP-M28

Taping name
Reel embossed carrier tape(HSOP-M28)

B A 5 9 6 8 F P - E 2

ROHM product name

Part No.

Package HSOP-28

Taping name
Reel embossed carrier tape(HSOP28)

● Tape and Reel information

HSOP28 / HSOP-M28

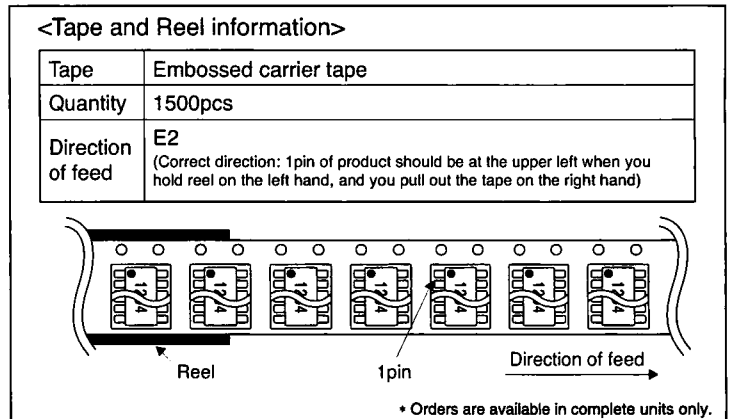
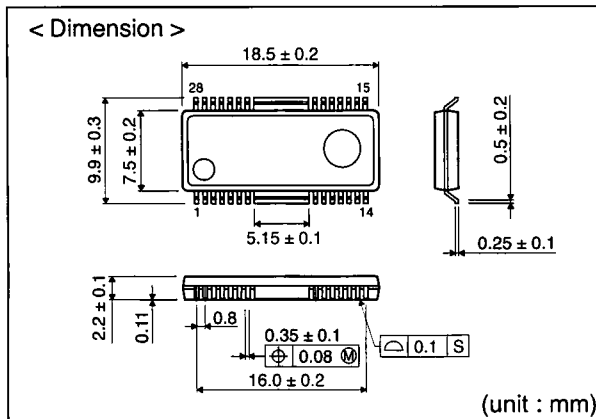

HSOP-M36

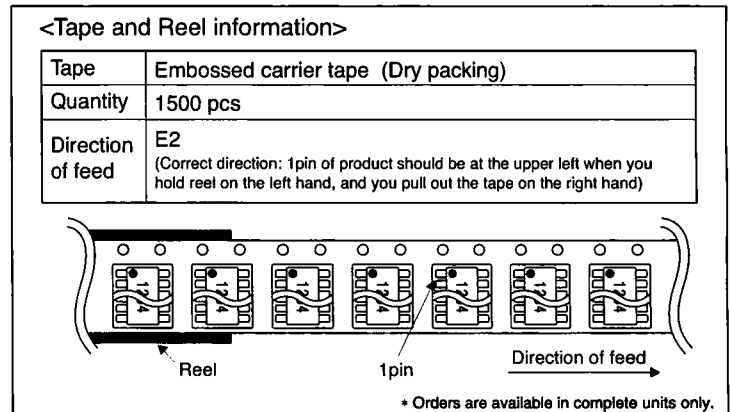
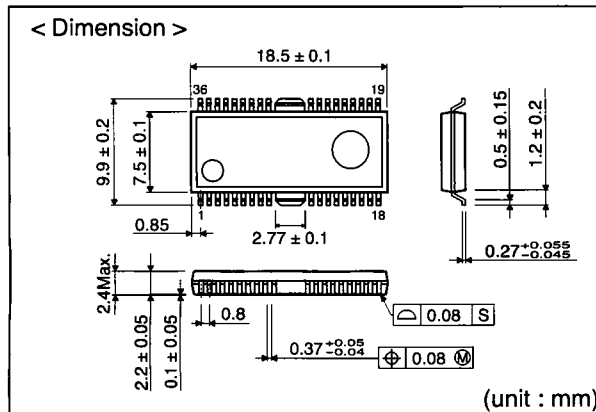

- The contents described herein are correct as of September, 2008
- The contents described herein are subject to change without notice. For updates of the latest information, please contact and confirm with ROHM CO.,LTD.
- Any part of this application note must not be duplicated or copied without our permission.
- Application circuit diagrams and circuit constants contained herein are shown as examples of standard use and operation. Please pay careful attention to the peripheral conditions when designing circuits and deciding upon circuit constants in the set.
- Any data, including, but not limited to application circuit diagrams and information, described herein are intended only as illustrations of such devices and not as the specifications for such devices. ROHM CO.,LTD. disclaims any warranty that any use of such devices shall be free from infringement of any third party's intellectual property rights or other proprietary rights, and further, assumes no liability of whatsoever nature in the event of any such infringement, or arising from or connected with or related to the use of such devices.
- Upon the sale of any such devices, other than for buyer's right to use such devices itself, resell or otherwise dispose of the same, implied right or license to practice or commercially exploit any intellectual property rights or other proprietary rights owned or controlled by ROHM CO., LTD. is granted to any such buyer.
- The products described herein utilize silicon as the main material.
- The products described herein are not designed to be X ray proof.

The products listed in this catalog are designed to be used with ordinary electronic equipment or devices (such as audio visual equipment, office-automation equipment, communications devices, electrical appliances and electronic toys). Should you intend to use these products with equipment or devices which require an extremely high level of reliability and the malfunction of which would directly endanger human life (such as medical instruments, transportation equipment, aerospace machinery, nuclear-reactor controllers, fuel controllers and other safety devices), please be sure to consult with our sales representative in advance.

Contact us for further information about the products.

Excellence in Electronics

ROHM

ROHM CO., LTD.

21, Saiin Mizosaki-cho, Ukyo-ku, Kyoto
615-8585, Japan
TEL: +81-75-311-2121 FAX: +81-75-315-0172
URL <http://www.rohm.com>

Published by
LSI Application Engineering Dept.

Seoul	TEL: +82-2-8182-700	FAX: +82-2-8182-715	Bangkok	TEL: +66-2-254-4890	FAX: +66-2-256-6334
Masan	TEL: +82-55-240-6234	FAX: +82-55-240-6236	Kuala Lumpur	TEL: +60-3-7958-8355	FAX: +60-3-7958-8377
Dalian	TEL: +86-411-8230-8549	FAX: +86-411-8230-8537	Penang	TEL: +60-4-6585084	FAX: +60-4-6585167
Beijing	TEL: +86-10-8525-2483	FAX: +86-10-8525-2489	Dusseldorf	TEL: +49-2145-9210	FAX: +49-2154-921400
Tianjin	TEL: +86-22-23029181	FAX: +86-22-23029183	Munich	TEL: +49-8161-48310	FAX: +49-8161-483120
Shanghai	TEL: +86-21-6279-2727	FAX: +86-21-6247-2066	Stuttgart	TEL: +49-711-72723710	FAX: +49-711-72723720
Hangzhou	TEL: +86-571-87658072	FAX: +86-571-87658071	France	TEL: +33-1-5697-3060	FAX: +33-1-5697-3080
Nanjing	TEL: +86-25-8689-0015	FAX: +86-25-8689-0393	United Kingdom	TEL: +44-1-908-306700	FAX: +44-1-908-235788
Ningbo	TEL: +86-574-87654201	FAX: +86-574-87654208	Denmark	TEL: +45-3694-4739	FAX: +45-3694-4789
Qingdao	TEL: +86-532-5779-312	FAX: +86-532-5779-653	Barcelona	TEL: +34-9375-24320	FAX: +34-9375-24410
Suzhou	TEL: +86-512-6807-1300	FAX: +86-512-6807-2300	Malaga	TEL: +34-9520-20263	FAX: +34-9520-20023
Tianjin	TEL: +86-22-23029181	FAX: +86-22-23029183	Hungary	TEL: +36-1-4719338	FAX: +36-1-4719339
Wuxi	TEL: +86-510-82702693	FAX: +86-510-82702992	Poland	TEL: +48-22-5757213	FAX: +48-22-5757001
Hong Kong	TEL: +852-2-740-6262	FAX: +852-2-375-8971	Russia	TEL: +7-95-980-6755	FAX: +7-95-937-8290
Dongguan	TEL: +86-769-393-3320	FAX: +86-769-398-4140	San Diego	TEL: +1-858-625-3630	FAX: +1-858-625-3670
Fuzhou	TEL: +86-591-8801-8698	FAX: +86-591-8801-8690	Atlanta	TEL: +1-770-754-5972	FAX: +1-770-754-0691
Guangzhou	TEL: +86-20-8364-9796	FAX: +86-20-8364-9707	Boston	TEL: +1-978-371-0382	FAX: +1-928-438-7164
Shenzhen	TEL: +86-755-8307-3001	FAX: +86-755-8307-3003	Chicago	TEL: +1-847-368-1006	FAX: +1-847-368-1008
Xiamen	TEL: +86-592-239-8382	FAX: +86-592-239-8380	Dallas	TEL: +1-972-312-8818	FAX: +1-972-312-0330
Zhuhai	TEL: +86-756-3232-480	FAX: +86-756-3232-460	Denver	TEL: +1-303-708-0908	FAX: +1-303-708-0858
Taipei	TEL: +866-2-2500-6956	FAX: +866-2-2503-2869	Nashville	TEL: +1-615-620-6700	FAX: +1-615-620-6702
Kaohsiung	TEL: +886-7-237-0881	FAX: +886-7-238-7332	Guadalajara	TEL: +52-33-3123-2001	FAX: +52-33-3123-2002
Singapore	TEL: +65-6332-2322	FAX: +65-6332-5662			
Manila	TEL: +63-2-807-6872	FAX: +63-2-809-1422			

Notes

- No technical content pages of this document may be reproduced in any form or transmitted by any means without prior permission of ROHM CO.,LTD.
- The contents described herein are subject to change without notice. The specifications for the product described in this document are for reference only. Upon actual use, therefore, please request that specifications to be separately delivered.
- Application circuit diagrams and circuit constants contained herein are shown as examples of standard use and operation. Please pay careful attention to the peripheral conditions when designing circuits and deciding upon circuit constants in the set.
- Any data, including, but not limited to application circuit diagrams information, described herein are intended only as illustrations of such devices and not as the specifications for such devices. ROHM CO.,LTD. disclaims any warranty that any use of such devices shall be free from infringement of any third party's intellectual property rights or other proprietary rights, and further, assumes no liability of whatsoever nature in the event of any such infringement, or arising from or connected with or related to the use of such devices.
- Upon the sale of any such devices, other than for buyer's right to use such devices itself, resell or otherwise dispose of the same, no express or implied right or license to practice or commercially exploit any intellectual property rights or other proprietary rights owned or controlled by
- ROHM CO., LTD. is granted to any such buyer.
- Products listed in this document are no antiradiation design.

The products listed in this document are designed to be used with ordinary electronic equipment or devices (such as audio visual equipment, office-automation equipment, communications devices, electrical appliances and electronic toys).

Should you intend to use these products with equipment or devices which require an extremely high level of reliability and the malfunction of which would directly endanger human life (such as medical instruments, transportation equipment, aerospace machinery, nuclear-reactor controllers, fuel controllers and other safety devices), please be sure to consult with our sales representative in advance.

It is our top priority to supply products with the utmost quality and reliability. However, there is always a chance of failure due to unexpected factors. Therefore, please take into account the derating characteristics and allow for sufficient safety features, such as extra margin, anti-flammability, and fail-safe measures when designing in order to prevent possible accidents that may result in bodily harm or fire caused by component failure. ROHM cannot be held responsible for any damages arising from the use of the products under conditions out of the range of the specifications or due to non-compliance with the NOTES specified in this catalog.

Thank you for your accessing to ROHM product informations.

More detail product informations and catalogs are available, please contact your nearest sales office.

ROHM Customer Support System

THE AMERICAS / EUROPE / ASIA / JAPAN

www.rohm.com

Contact us : webmaster@rohm.co.jp