

Click [here](#) to ask an associate for production status of specific part numbers.

MAX77642/MAX77643

Ultra Configurable PMIC Featuring 93% Peak Efficiency Single-Inductor, 3-Output Buck-Boost, 1-LDO for Long Battery Life

General Description

The MAX77642/MAX77643 provide power supply solutions for low-power applications where size and efficiency are critical. The IC features a SIMO buck-boost regulator that provides three independently programmable power rails from a single inductor to minimize total solution size. A 150mA LDO provides ripple rejection for audio and other noise-sensitive applications. The LDO can also be configured as load switches to manage power consumption by disconnecting external blocks when not required.

The MAX77642's SIMO and LDO output voltages are individually programmable through resistors. A peak current limit input is used to set both the inductor's peak current limits of the device with a single resistor. Individual enable pins combined with the flexible resistor programmability allows the device to be tailored for many applications.

This MAX77643's SIMO and LDO output voltages are individually programmable through I²C and in addition, includes two GPIOs with alternate modes for scalability. A bidirectional I²C serial interface allows for configuring and checking the status of the devices. An internal on/off controller provides a controlled startup sequence for the regulators and provides supervisory functionality while they are on. Numerous factory programmable options allow the device to be tailored for many applications, enabling faster time to market.

Applications

- Next Generation Hearables
- Fitness, Health, and Activity Monitors
- Safety and Security Monitors
- Portable Consumer Devices

Benefits and Features

- Highly Integrated
 - 3x Output, Single-Inductor Multiple-Output (SIMO) Buck-Boost Regulator
 - Supports Wide Output Voltage Range from 0.5V to 5.5V for all SIMO Channels
 - 1x 150mA LDO
 - 100mA in LSW mode
 - 2x GPIOs (MAX77643)
 - Watchdog Timer (MAX77643)
- Ultra Low-Power SIMO
 - 5 μ A Operating Current (3x SIMO Channels + 1x LDOs)
 - 1 μ A Operating Current per SIMO Channel
 - 0.3 μ A Shutdown Current
 - 93% Peak Efficiency in Boost-Only Mode
 - 91% Peak Efficiency in Buck-Only Mode
 - Less Than 20mVpp Output Ripple at V_{OUT} = 1.8V
 - Automatic Low-Power Mode to Normal-Power Mode Transition
- Flexible and Configurable
 - Ultra-Configurable Resistor Programmable Output Voltages (MAX77642)
 - I²C-Programmable Output Voltages (MAX77643)
- Small Size
 - 4.24mm² Wafer-Level Package (WLP)
 - 25-Bump, 0.4mm Pitch, 5 x 5 Array

Ordering Information appears at end of data sheet.

19-100912; Rev 4; 10/21

© 2021 Analog Devices, Inc. All rights reserved. Trademarks and registered trademarks are the property of their respective owners.

One Analog Way, Wilmington, MA 01887 U.S.A. | Tel: 781.329.4700 | © 2021 Analog Devices, Inc. All rights reserved.

Simplified Block Diagram

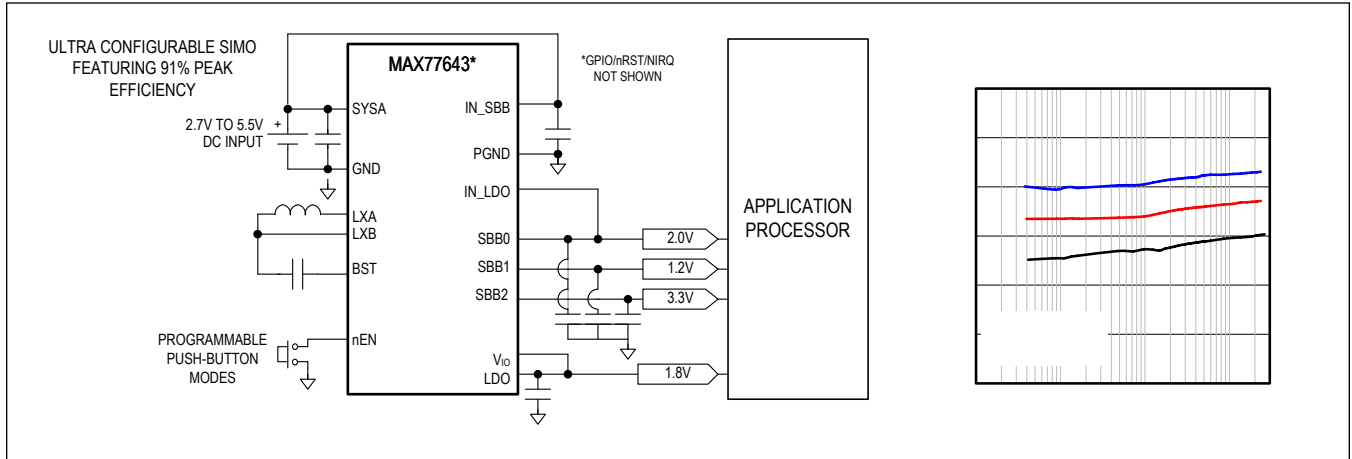

MAX77642/MAX77643

Ultra Configurable PMIC Featuring 93% Peak Efficiency Single-Inductor, 3-Output Buck-Boost, 1-LDO for Long Battery Life Applications

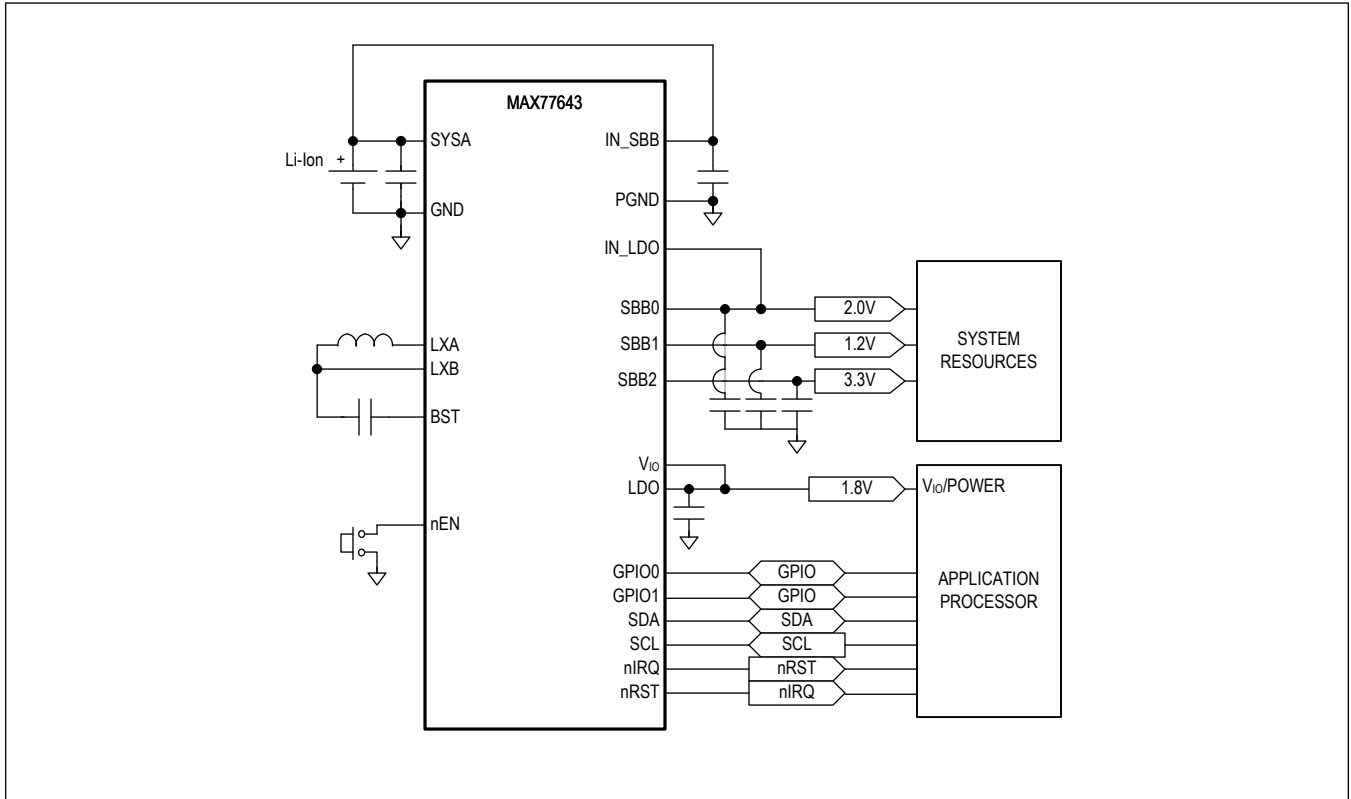

TABLE OF CONTENTS

General Description	1
Applications	1
Benefits and Features	1
Simplified Block Diagram	2
Absolute Maximum Ratings	9
Package Information	9
WLP	9
Electrical Characteristics	10
Electrical Characteristics—Global Resources	10
Electrical Characteristics—SIMO Buck-Boost	13
Electrical Characteristics—Low Dropout Linear Regulator (LDO)/Load Switch (LSW)	14
Electrical Characteristics—I ² C Serial Communication	15
Typical Operating Characteristics	18
Pin Configurations	23
MAX77642	23
MAX77643	24
Pin Description	25
Detailed Description	27
Part Number Decoding	27
Detailed Description—Global Resources	30
Features and Benefits	30
Voltage Monitors	30
SYSA POR Comparator	30
SYSA Undervoltage-Lockout Comparator	30
SYSA Overvoltage-Lockout Comparator	30
Thermal Monitors	30
Chip Identification	31
nEN Enable Input (MAX77643)	31
EN Enable Input (MAX77642)	31
nEN Manual Reset (MAX77643)	31
nEN Triple-Functionality: Push-Button vs. Slide-Switch vs. Logic (MAX77643)	32
nEN Internal Pullup Resistors to V _{SYS A}	33
Interrupts (nIRQ) (MAX77643)	33
Reset Output (nRST) (MAX77643)	33
General-Purpose Input Output (GPIO) (MAX77643)	34
Alternate Mode (MAX77643)	35
On/Off Controller	36
Top Level On/Off Controller (MAX77642)	37
On/Off Controller Transition Table (MAX77642)	38

TABLE OF CONTENTS (CONTINUED)

Top Level On/Off Controller (MAX77643)	39
On/Off Controller Transition Table (MAX77643)	40
Internal Wake-Up Flags (MAX77643)	40
Reset, Off, and Auto Wake-Up Sequences (MAX77643)	41
Power-Up/Down Sequence (MAX77643)	42
Flexible Power Sequencer (FPS) (MAX77643)	43
Startup Timing Diagram Due to nEN (MAX77643)	44
Force Enabled/Disabled Channels (MAX77643)	44
Debounced Inputs (nEN, GPI) (MAX77643)	45
Watchdog Timer (WDT) (MAX77643)	46
Detailed Description—SIMO Buck-Boost	47
SIMO Features and Benefits	47
SIMO Detailed Block Diagram	48
SIMO Control Scheme	49
Drive Strength (MAX77643)	49
SIMO Output Voltage Configuration	50
Peak Current Configuration	52
SIMO Soft-Start	52
SIMO Registers (MAX77643)	53
SIMO Active Discharge Resistance	53
SIMO Buck Mode (MAX77643)	54
SIMO Boost Mode (MAX77643)	54
Applications Information	55
SIMO Available Output Current	55
Inductor Selection	55
Input Capacitor Selection	56
Boost Capacitor Selection	56
Output Capacitor Selection	56
SIMO Switching Frequency	56
Unused Outputs	57
PCB Layout Guide	57
Capacitors	57
Input Capacitor at IN_SBB	57
Output Capacitors at SBBx	57
Inductor	58
Ground Connections	58
Example PCB Layout	58
Detailed Description—Low Dropout Linear Regulator (LDO)/Load Switch (LSW)	59
Features and Benefits	59

TABLE OF CONTENTS (CONTINUED)

LDO/LSW Simplified Block Diagram	59
LDO Output Voltage Configuration	59
LDO/LSW Active-Discharge Resistor	60
LDO/LSW Soft-Start	61
Load Switch Configuration	61
Applications Information	62
Input Capacitor Selection	62
Output Capacitor Selection	62
Detailed Description—I ² C Serial Communication	63
General Description	63
Features	63
I ² C Simplified Block Diagram	63
I ² C System Configuration	64
I ² C Interface Power	64
I ² C Data Transfer	64
I ² C Start and Stop Conditions	64
I ² C Acknowledge Bit	65
I ² C Slave Address	66
I ² C Clock Stretching	66
I ² C General Call Address	66
I ² C Device ID	66
I ² C Communication Speed	67
I ² C Communication Protocols	67
Writing to a Single Register	67
Writing Multiple Bytes to Sequential Registers	68
Reading from a Single Register	70
Reading from Sequential Registers	71
Engaging HS-Mode for Operation up to 3.4MHz	72
Register Map	73
MAX77643	73
Register Details	74
Typical Application Circuits	89
Typical Applications Circuit	89
Ordering Information	90
Revision History	91

LIST OF FIGURES

Figure 1. Part Number Decode	27
Figure 2. EN Pulldown.	31
Figure 3. nEN Usage Timing Diagram	32
Figure 4. nEN Pullup Resistor Configuration.	33
Figure 5. GPIOx Block Diagram	35
Figure 6. Top Level On/Off Controller State Diagram (MAX77642)	37
Figure 7. Top Level On/Off Controller State Diagram (MAX77643)	39
Figure 8. On/Off Controller Reset and Off-Action Sequences.	41
Figure 9. Power-Up/Down Sequence	42
Figure 10. Flexible Power Sequencer Basic Timing Diagram	43
Figure 11. Startup Timing Diagram Due to nEN	44
Figure 12. Debounced Inputs	45
Figure 13. Watchdog Timer State Machine.	46
Figure 14. SIMO Detailed Block Diagram	48
Figure 15. PCB Top-Layer and Component Placement Example	58
Figure 16. LDO Simplified Block Diagram.	59
Figure 17. LDO to LSW Transition Waveform.	61
Figure 18. I ² C Simplified Block Diagram.	63
Figure 19. I ² C System Configuration	64
Figure 20. I ² C Start and Stop Conditions	65
Figure 21. Acknowledge Bit.	65
Figure 22. Slave Address Example	66
Figure 23. Writing to a Single Register with the Write Byte Protocol	68
Figure 24. Writing to Sequential Registers X to N.	69
Figure 25. Reading from a Single Register with the Read Byte Protocol	70
Figure 26. Reading Continuously from Sequential Registers X to N.	71
Figure 27. Engaging HS Mode	72
Figure 28. Typical Applications Circuit - R _{SEL} Version (MAX77642)	89
Figure 29. Typical Applications Circuit - I ² C Version (MAX77643)	90

LIST OF TABLES

Table 1. Regulator Summary	27
Table 2. Variants Table	27
Table 3. OTP Options Table	28
Table 4. GPIO MODE	35
Table 5. On/Off Controller Transition/State (MAX77642)	38
Table 6. On/Off Controller Transition/State (MAX77643)	40
Table 7. Watchdog Timer Factory-Programmed Safety Options	46
Table 8. SBB0 Output Voltage Settings	50
Table 9. SBB1/2 Output Voltage Settings	51
Table 10. Inductor Peak Current Setting	52
Table 11. SIMO Available Output Current for Common Applications	55
Table 12. Switching Frequency Control	56
Table 13. LDO Output Voltage Setting	60
Table 14. I ² C Slave Address Options	66

Absolute Maximum Ratings

nEN, nIRQ, nRST, RSET_SBB0, RSET_SBB1, RSET_SBB2, RSET_LDO, RSET_IPK, EN0, EN1, EN3 to GND -0.3V to $V_{SYS_A} + 0.3V$	BST to IN -0.3V to +6.0V
SCL, SDA to GND -0.3V to $V_{IO} + 0.3V$	BST to LXB -0.3V to +6.0V
V_{SYS_A} to GND -0.3V to +6.0V	SBB0, SBB1, SBB2 Short-Circuit Duration Continuous
nIRQ, nRST, SDA, GPIO Continuous Current $\pm 20mA$	PGND to GND -0.3V to +0.3V
IN_SBB Continuous Current (Note 1) $1.2A_{RMS}$	Operating Temperature Range -40°C to +125°C
IN_SBB to GND -0.3V to +6.0V	Junction Temperature +150°C
LDO to GND -0.3V to $V_{IN_LDO} + 0.3V$	Storage Temperature Range -65°C to +150°C
IN_LDO to GND -0.3V to $V_{SYS_A} + 0.3V$	Soldering Temperature (reflow) +260°C
LXA Continuous Current (Note 2) $1.2A_{RMS}$	Continuous Power Dissipation (Multilayer Board, $T_A = +70^\circ C$, derate 20.4mW/°C above +70°C) 1632mW
LXB Continuous Current (Note 2) $1.2A_{RMS}$	GPIO0/1 to GND -0.3V to $V_{IO} + 0.3V$
SBB0, SBB1, SBB2 to PGND -0.3V to +6.0V	SYS_A to GND -0.3V to +6.0V
		V_{IO} -0.3V to $SYS_A + 0.3V$

Note 1: Do not repeatedly hot-plug a source to the IN terminal at a rate greater than 10Hz. Hot plugging low impedance sources results in an ~8A momentary (~2µs) current spike.

Note 2: Do not externally bias LXA or LXB. LXA has internal clamping diodes to PGND and IN. LXB has an internal low-side clamping diode to PGND and an internal high-side clamping diode that dynamically connects to a selected SIMO output. It is normal for these diodes to briefly conduct during switching events. When the SIMO regulator is disabled, the LXB to PGND absolute maximum voltage is -0.3V to $V_{SBB0} + 0.3V$.

Stresses beyond those listed under "Absolute Maximum Ratings" may cause permanent damage to the device. These are stress ratings only, and functional operation of the device at these or any other conditions beyond those indicated in the operational sections of the specifications is not implied. Exposure to absolute maximum rating conditions for extended periods may affect device reliability.

Package Information

WLP

Package Code	N252B2+1
Outline Number	21-100480
Land Pattern Number	Refer to Application Note 1891
Thermal Resistance, Four-Layer Board:	
Junction to Ambient (θ_{JA})	49°C/W (2s2p board)

For the latest package outline information and land patterns (footprints), go to www.maximintegrated.com/packages. Note that a "+", "#", or "-" in the package code indicates RoHS status only. Package drawings may show a different suffix character, but the drawing pertains to the package regardless of RoHS status.

Package thermal resistances were obtained using the method described in JEDEC specification JESD51-7, using a four-layer board. For detailed information on package thermal considerations, refer to www.maximintegrated.com/thermal-tutorial.

Electrical Characteristics

($V_{IN_SBB} = V_{IN_LDO} = V_{SYS A} = 3.7V$, $V_{IO} = 1.8V$, limits are 100% production tested at $T_A = +25^\circ C$. Limits over the operating temperature range ($T_A = -40^\circ C$ to $+125^\circ C$) are guaranteed by design and characterization, unless otherwise noted.)

PARAMETER	SYMBOL	CONDITIONS		MIN	TYP	MAX	UNITS
Operating Voltage Range	V_{IN}			2.7		5.5	V
Shutdown Supply Current	I_{SHDN}	Current measured into IN_SBB and IN_LDO, all resources are off (LDO, SBB0, SBB1, SBB2), $T_A = +25^\circ C$	Main bias is off; this is the standby state		0.3	1	μA
Main Bias Quiescent Current	I_Q	Main bias is in normal-power mode (CNFG_GLBL.SBIA_LPM = 0)			28		μA
Quiescent Supply Current	I_Q	Current measured into IN_SBB and IN_LDO. LDO0, SBB0, SBB1, SBB2 are enabled with no load watchdog timer disabled	Main bias is in low-power mode (CNFG_GLBL.SBIA_LPM = 1)		4.5	11	μA

Electrical Characteristics—Global Resources

($V_{IN_SBB} = V_{IN_LDO} = V_{SYS A} = 3.7V$, limits are 100% production tested at $T_A = +25^\circ C$, limits over the operating temperature range ($T_A = -40^\circ C$ to $+125^\circ C$) are guaranteed by design and characterization, unless otherwise noted.)

PARAMETER	SYMBOL	CONDITIONS	MIN	TYP	MAX	UNITS
GENERAL CHARACTERISTICS						
Main Bias Enable Time	t_{SBIA_EN}			0.5		ms
VOLTAGE MONITORS / POWER-ON RESET (POR)						
POR Threshold	V_{POR}	$V_{SYS A}$ falling		1.55		V
POR Threshold Hysteresis				150		mV
VOLTAGE MONITORS / UNDERVOLTAGE LOCKOUT (UVLO)						
UVLO Threshold	$V_{SYS AU VLO}$	$V_{SYS A}$ falling, UVLO_F[3:0] = 0xA (Note 3)	2.45	2.6	2.73	V
UVLO Threshold Hysteresis	$V_{SYS AU VLO_HYS}$	TUVH[3:0] = 0x5 (Note 3)		300		mV
VOLTAGE MONITORS / OVERVOLTAGE LOCKOUT (OVLO)						
OVLO Threshold	$V_{SYS AO VLO}$	$V_{SYS A}$ rising	5.70	5.85	6.00	V
THERMAL MONITORS						
Overtemperature Lockout Threshold	T_{OTLO}	T_J rising		145		$^\circ C$
Thermal Alarm Temperature 1	T_{JAL1}	T_J rising		80		$^\circ C$
Thermal Alarm Temperature 2	T_{JAL2}	T_J rising		100		$^\circ C$

Electrical Characteristics—Global Resources (continued)

($V_{IN_SBB} = V_{IN_LDO} = V_{SYSA} = 3.7V$, limits are 100% production tested at $T_A = +25^\circ C$, limits over the operating temperature range ($T_A = -40^\circ C$ to $+125^\circ C$) are guaranteed by design and characterization, unless otherwise noted.)

PARAMETER	SYMBOL	CONDITIONS		MIN	TYP	MAX	UNITS
Thermal Alarm Temperature Hysteresis					15		$^\circ C$
ENABLE INPUT (nEN, ENx)							
nEN Input Leakage Current	I_{nEN_LKG}	$V_{nEN} = V_{SYSA} = 5.5V$	$T_A = +25^\circ C$	-1	± 0.001	+1	μA
			$T_A = +85^\circ C$		± 0.01		
nEN Input Falling Threshold	$V_{TH_nEN_F}$	nEN Falling		0.4			V
nEN Input Rising Threshold	$V_{TH_nEN_R}$	nEN rising				1.4	V
EN Input Threshold, High	V_{IH}	Voltage threshold, rising		1.4			V
EN Input Threshold, Low	V_{IL}	Voltage threshold, falling				0.4	V
Debounce Time	t_{DBNC_nEN}	CNFG_GLBL0.DBEN_nEN = 0			500		μs
		CNFG_GLBL0.DBEN_nEN = 1			30		ms
Manual Reset Time	t_{MRST}	CNFG_GLBL0.T_MRST = 1		3	4	5	s
		CNFG_GLBL0.T_MRST = 0		7	8	10.5	
nEN Internal Pullup	R_{nEN_PU}	Pullup to V_{SYSA}	CNFG_GLBL0.PU_DIS = 0		200		k Ω
			CNFG_GLBL0.PU_DIS = 1		10000		
EN Internal Pulldown	R_{EN_PD}	Pulldown to GND			50		nA
OPEN-DRAIN INTERRUPT OUTPUT (nIRQ)							
Output Voltage Low	V_{OL}	$I_{SINK} = 2mA$				0.4	V
Output Falling Edge Time	t_{f_nIRQ}	$C_{IRQ} = 25pF$			2		ns
Leakage Current	I_{nIRQ_LKG}	$V_{SYSA} = V_{IO} = 5.5V$ nIRQ is high impedance (no interrupts) $V_{nIRQ} = 0V$ and $5.5V$	$T_A = +25^\circ C$	-1	± 0.001	+1	μA
			$T_A = +85^\circ C$		± 0.01		
OPEN-DRAIN RESET OUTPUT (nRST)							
Output Voltage Low	V_{OL}	$I_{SINK} = 2mA$				0.4	V
Output Falling Edge Time	t_{f_nRST}	$C_{RST} = 25pF$			2		ns
nRST Deassert Delay Time	t_{RSTODD}	See Figure 11 for more information			5.12		ms
nRST Assert Delay Time	t_{RSTOAD}				10.24		ms

Electrical Characteristics—Global Resources (continued)

($V_{IN_SBB} = V_{IN_LDO} = V_{SYS} = 3.7V$, limits are 100% production tested at $T_A = +25^\circ C$, limits over the operating temperature range ($T_A = -40^\circ C$ to $+125^\circ C$) are guaranteed by design and characterization, unless otherwise noted.)

PARAMETER	SYMBOL	CONDITIONS		MIN	TYP	MAX	UNITS
Leakage Current	I_{nRST_LKG}	$V_{SYS} = V_{IO} = 5.5V$ nRST is high impedance (no reset) $V_{nRST} = 0V$ and $5.5V$	$T_A = +25^\circ C$	-1	± 0.001	+1	μA
		$V_{SYS} = V_{IO} = 5.5V$ nRST is high impedance (no reset) $V_{nRST} = 0V$ and $5.5V$	$T_A = +85^\circ C$			± 0.01	
GENERAL PURPOSE INPUT/OUTPUT (GPIO)							
GPIO Supply Voltage Range					V_{IO}		V
Input Voltage Low	V_{IL}	$V_{IO} = 1.8V$				$0.3 \times V_{IO}$	V
Input Voltage High	V_{IH}	$V_{IO} = 1.8V$		$0.7 \times V_{IO}$			V
Input Leakage Current	I_{GPI_LKG}	CNFG_GPIOx.DIR = 1 $V_{IO} = 5.5V$ $V_{GPIO} = 0V$ and $5.5V$	$T_A = +25^\circ C$	-1	± 0.001	+1	μA
			$T_A = +85^\circ C$			± 0.01	
Output Voltage Low	V_{OL}	$I_{SINK} = 2mA$				0.4	V
Output Voltage High	V_{OH}	$I_{SOURCE} = 1mA$		$0.8 \times V_{IO}$			V
Input Debounce Time	t_{DBNC_GPI}	CNFG_GPIOx.DBEN_GPI = 1			30		ms
Output Falling Edge Time	t_f_GPIO	$C_{GPIO} = 25pF$			3		ns
Output Rising Edge Time	t_r_GPIO	$C_{GPIO} = 25pF$			3		ns
FLEXIBLE POWER SEQUENCER							
FPS Startup Delay	t_{FPS_DLY}				1.43		ms
Power-Up Event Periods	t_{EN}	See Figure 10			1.28		ms
Power-Down Event Periods	t_{DIS}	See Figure 10			2.56		ms
RSET (MAX77642)							
Select Resistor Detection Time	t_{RSET}	Total time to detect all five resistors	$V_{IN_SBB} = 2.7V$, $C_{RSET} < 2pF$		3		ms
Required Select Resistor Accuracy	R_{SEL_TOL}	Use the nearest $\pm 1\%$ resistor from the R_{SEL} Selection Table.		-1		+1	%

Note 3: Programmed at Maxim's factory.

Electrical Characteristics—SIMO Buck-Boost

($V_{IN_SBB} = V_{IN_LDO} = V_{SYS_A} = 3.7V$, $C_{SBBx} = 10\mu F$, $L = 1.5\mu H$, limits are 100% production tested at $T_A = +25^\circ C$, limits over the operating temperature range ($T_A = -40^\circ C$ to $+125^\circ C$) are guaranteed by design and characterization, unless otherwise noted.)

PARAMETER	SYMBOL	CONDITIONS		MIN	TYP	MAX	UNITS
GENERAL CHARACTERISTICS / OUTPUT VOLTAGE RANGE (SBB0)							
Programmable Output Voltage Range				0.5		5.5	V
Output DAC Bits					8		bits
Output DAC LSB Size		0.5V to 5.5V			25		mV
GENERAL CHARACTERISTICS / OUTPUT VOLTAGE RANGE (SBB1)							
Programmable Output Voltage Range				0.5		5.5	V
Output DAC Bits					8		bits
Output DAC LSB Size		0.5V to 5.5V			25		mV
GENERAL CHARACTERISTICS / OUTPUT VOLTAGE RANGE (SBB2)							
Programmable Output Voltage Range				0.5		5.5	V
Output DAC Bits					8		bits
Output DAC LSB Size		0.5V to 5.5V			25		mV
OUTPUT VOLTAGE ACCURACY							
Output Voltage Accuracy		V_{SBBx} falling, threshold where LXA switches high. Specified as a percentage of target output voltage.	$T_A = -40^\circ C$ to $+125^\circ C$	-2.0		+2.0	%
OUT Over-Regulation Threshold	V_{OV}	$T_A = +25^\circ C$			1.7	3.3	%
TIMING CHARACTERISTICS							
Enable Delay		Delay time from the SIMO receiving its first enable signal to when it begins to switch in order to service that output			10		μs
Soft-Start Slew Rate	dV/dt_{SS}	$I_{PK} = 1A$, $C_{OUT} = 10\mu F$			5.0		$mV/\mu s$
POWER STAGE CHARACTERISTICS							
LXA Leakage Current		SBB0, SBB1, SBB2 are disabled, $V_{IN_SBB} = 5.5V$, $V_{LXA} = 0V$, or $5.5V$	$T_A = +25^\circ C$	-1.0	± 0.1	+1.0	μA
			$T_A = +85^\circ C$		± 1.0		
LXB Leakage Current		SBB0, SBB1, SBB2 are disabled, $V_{IN_SBB} = 5.5V$, $V_{LXA} = 0V$ or $5.5V$, all $V_{SBBx} = 5.5V$	$T_A = +25^\circ C$	-1.0	± 0.1	+1.0	μA
			$T_A = +85^\circ C$		± 1.0		
BST Leakage Current		$V_{IN_SBB} = 5.5V$, $V_{LXB} = 5.5V$, $V_{BST} = 11V$	$T_A = +25^\circ C$		+0.01	+1.0	μA
			$T_A = +85^\circ C$		+0.1		

Electrical Characteristics—SIMO Buck-Boost (continued)

($V_{IN_SBB} = V_{IN_LDO} = V_{SYS} = 3.7V$, $C_{SBBx} = 10\mu F$, $L = 1.5\mu H$, limits are 100% production tested at $T_A = +25^\circ C$, limits over the operating temperature range ($T_A = -40^\circ C$ to $+125^\circ C$) are guaranteed by design and characterization, unless otherwise noted.)

PARAMETER	SYMBOL	CONDITIONS	MIN	TYP	MAX	UNITS
Disabled Output Leakage Current		SBB0, SBB1, SBB2 are disabled, active-discharge disabled (CNFG_SBBx_B.ADE_SBBx = 0), $V_{SBBx} = 5.5V$, $V_{LXB} = 0V$, $V_{SYS} = V_{IN_SBB} = V_{BST} = 5.5V$	$T_A = +25^\circ C$	+0.1	+1.0	μA
		$T_A = +85^\circ C$		+0.2		
Active Discharge Resistance	RAD_SBBx	SBB0, SBB1, SBB2 are disabled, active discharge enabled (CNFG_SBBx_B.ADE_SBBx = 1)	60	120	180	Ω
CONTROL SCHEME						
Peak Current Limit	IP_SBB (Note 4)	CNFG_SBBx_B.IP_SBBx[1:0] = 0b11	-18%	0.335	+18%	A
		CNFG_SBBx_B.IP_SBBx[1:0] = 0b10	-14%	0.500	+14%	
		CNFG_SBBx_B.IP_SBBx[1:0] = 0b01	-8%	0.750	+8%	
		CNFG_SBBx_B.IP_SBBx[1:0] = 0b00	-7%	1.000	+7%	

Note 4: Typical values align with bench observations using the stated conditions with an inductor. Minimum and maximum values are tested in production with DC currents without an inductor. See the *Typical Operating Characteristics* SIMO switching waveforms to gain more insight on this specification.

Electrical Characteristics—Low Dropout Linear Regulator (LDO)/Load Switch (LSW)

($V_{IN_SBB} = V_{IN_LDO} = V_{SYS} = 3.7V$, limits are 100% production tested at $T_A = +25^\circ C$, limits over the operating temperature range ($T_A = -40^\circ C$ to $+125^\circ C$) are guaranteed by design and characterization, unless otherwise noted.)

PARAMETER	SYMBOL	CONDITIONS	MIN	TYP	MAX	UNITS
LDO						
Input Voltage Range	V_{IN_LDO}	LDO mode	1.71		5.5	V
		Switch mode	1.2		5.5	
Quiescent Supply Current	I_{IN_LDO}	$I_{OUT_LDOx} = 0$		1.4	2.4	μA
		$I_{OUT_LDOx} = 0$, switch mode		0.5	1.2	
Quiescent Supply Current In Dropout	$I_{IN_DRP_LDO}$	$I_{OUT_LDOx} = 0$, $V_{IN_LDOx} = 2.9V$, $V_{LDOx} = 3V$		2.1	4.6	μA
Maximum Output Current	I_{OUT_LDO}	$V_{IN_LDOx} > 1.8V$	150			mA
		$V_{IN_LDOx} = 1.8V$ or lower	100			
Output Voltage (MAX77642)	V_{OUT_LDO}		0.5		3.975	V
Output Voltage (MAX77643)	V_{OUT_LDO}		0.5		5.0	V
Output Accuracy		$V_{IN_LDOx} = (V_{OUT_LDOx} + 0.5V)$ or higher, $I_{OUT_LDOx} = 1mA$	-3.1		+3.1	%
Dropout Voltage	V_{DRP_LDO}	$V_{IN_LDOx} = 3V$, LDOx programmed to 3V, $I_{OUT_LDOx} = 100mA$			100	mV

Electrical Characteristics—Low Dropout Linear Regulator (LDO)/Load Switch (LSW) (continued)

($V_{IN_SBB} = V_{IN_LDO} = V_{SYS_A} = 3.7V$, limits are 100% production tested at $T_A = +25^\circ C$, limits over the operating temperature range ($T_A = -40^\circ C$ to $+125^\circ C$) are guaranteed by design and characterization, unless otherwise noted.)

PARAMETER	SYMBOL	CONDITIONS	MIN	TYP	MAX	UNITS
Line Regulation		$V_{IN_LDOx} = (V_{OUT_LDOx} + 0.5 V)$ to 5.5V	-0.5		+0.5	%/V
Load Regulation		$V_{IN_LDOx} = 1.8V$ or higher, $I_{OUT_LDOx} = 100\mu A$ to 100mA		0.001	0.005	%/mA
Line Transient		$V_{IN_LDOx} = 4V$ to 5V, 5 μs rise time		± 35		mV
Load Transient		$I_{OUT_LDOx} = 100\mu A$ to 10mA, 200ns rise time		100		mV
		$I_{OUT_LDOx} = 100\mu A$ to 100mA, 200ns rise time		200		
Active Discharge Resistance	R_{AD_LDO}		42	80	200	Ω
Switch Mode On-Resistance	R_{ON_LDO}	$V_{IN_LDOx} = 2.7V$, $I_{OUT_LDOx} = 100mA$			0.5	Ω
		$V_{IN_LDOx} = 1.8V$, $I_{OUT_LDOx} = 50mA$			0.8	
		$V_{IN_LDOx} = 1.2V$, $I_{OUT_LDOx} = 5mA$			1.2	
Slew Rate		$I_{OUT_LDO} = 0mA$, time from 10% to 90% of final register value, $C_{OUT_LDO} = 1\mu F$		2.2		V/ms
		$I_{OUT_LDO} = 0mA$, time from 10% to 90% of final register value, $C_{OUT_LDO} = 1\mu F$, switch mode		2.2		
Short Circuit Current Limit		$V_{IN_LDOx} = 2.7V$, $V_{OUT_LDOx} = GND$	230	550	880	mA
		$V_{IN_LDOx} = 2.7V$, $V_{OUT_LDOx} = 2.55V$, switch mode	230	550		
Output Noise		10Hz to 100kHz, $V_{IN_LDOx} = 5V$, $V_{OUT_LDOx} = 3.3V$		150		μV_{RMS}
		10Hz to 100kHz, $V_{IN_LDOx} = 5V$, $V_{OUT_LDOx} = 2.5V$		125		
		10Hz to 100kHz, $V_{IN_LDOx} = 5V$, $V_{OUT_LDOx} = 1.2V$		90		
		10Hz to 100kHz, $V_{IN_LDOx} = 5V$, $V_{OUT_LDOx} = 0.9V$		80		
Output DAC Bits			8			bits
Output DAC LSB Size				25		mV

Electrical Characteristics—I²C Serial Communication

($V_{IN} = 3.7V$, $V_{IO} = 1.8V$, limits are 100% production tested at $T_A = +25^\circ C$, limits over the operating temperature range ($T_A = -40^\circ C$ to $+125^\circ C$) are guaranteed by design and characterization, unless otherwise noted.)

PARAMETER	SYMBOL	CONDITIONS	MIN	TYP	MAX	UNITS
POWER SUPPLY						
V_{IO} Voltage Range	V_{IO}		1.7	1.8	3.6	V
V_{IO} Bias Current		$V_{IO} = 3.6V$, $V_{SDA} = V_{SCL} = 0V$ or 3.6V, $T_A = +25^\circ C$	-1	0	+1	μA
		$V_{IO} = 1.7V$, $V_{SDA} = V_{SCL} = 0V$ or 1.7V	-1	0	+1	

Electrical Characteristics—^I2C Serial Communication (continued)

($V_{IN} = 3.7V$, $V_{IO} = 1.8V$, limits are 100% production tested at $T_A = +25^\circ C$, limits over the operating temperature range ($T_A = -40^\circ C$ to $+125^\circ C$) are guaranteed by design and characterization, unless otherwise noted.)

PARAMETER	SYMBOL	CONDITIONS	MIN	TYP	MAX	UNITS
SDA AND SCL I/O STAGE						
SCL, SDA Input High Voltage	V_{IH}	$V_{IO} = 1.7V$ to $3.6V$	0.7 x V_{IO}			V
SCL, SDA Input Low Voltage	V_{IL}	$V_{IO} = 1.7V$ to $3.6V$			0.3 x V_{IO}	V
SCL, SDA Input Hysteresis	V_{HYS}			0.05 x V_{IO}		V
SCL, SDA Input Leakage Current	I_I	$V_{IO} = 3.6V$, $V_{SCL} = V_{SDA} = 0V$ and $3.6V$	-10		+10	μA
SDA Output Low Voltage	V_{OL}	Sinking 20mA			0.4	V
SCL, SDA Pin Capacitance	C_I			10		pF
Output Fall Time from V_{IH} to V_{IL}	t_{OF} (Note 5)				120	ns
^I2C COMPATIBLE INTERFACE TIMING (STANDARD, FAST AND FAST MODE PLUS) (Note 5)						
Clock Frequency	f_{SCL}		0		1000	kHz
Hold Time (REPEATED) START Condition	t_{HD_STA}		0.26			μs
SCL Low Period	t_{LOW}		0.5			μs
SCL High Period	t_{HIGH}		0.26			μs
Setup Time REPEATED START Condition	t_{SU_STA}		0.26			μs
Data Hold Time	t_{HD_DAT}		0			μs
Data Setup Time	t_{SU_DAT}		50			ns
Setup Time for STOP Condition	t_{SU_STO}		0.26			μs
Bus Free Time between STOP and START Condition	t_{BUF}		0.5			μs
Pulse Width of Suppressed Spikes	t_{SP}	Maximum pulse width of spikes that must be suppressed by the input filter		50		ns
^I2C COMPATIBLE INTERFACE TIMING (HIGH-SPEED MODE, $C_B = 100pF$) (Note 5)						
Clock Frequency	f_{SCL}				3.4	MHz
Setup Time REPEATED START Condition	t_{SU_STA}		160			ns
Hold Time (REPEATED) START Condition	t_{HD_STA}		160			ns
SCL Low Period	t_{LOW}		160			ns
SCL High Period	t_{HIGH}		60			ns
Data Setup Time	t_{SU_DAT}		10			ns
Data Hold Time	t_{HD_DAT}		0		70	ns
SCL Rise Time	t_{rCL}	$T_A = +25^\circ C$	10		40	ns

Electrical Characteristics—I²C Serial Communication (continued)

($V_{IN} = 3.7V$, $V_{IO} = 1.8V$, limits are 100% production tested at $T_A = +25^\circ C$, limits over the operating temperature range ($T_A = -40^\circ C$ to $+125^\circ C$) are guaranteed by design and characterization, unless otherwise noted.)

PARAMETER	SYMBOL	CONDITIONS	MIN	TYP	MAX	UNITS
Rise Time of SCL Signal After REPEATED START Condition and After Acknowledge Bit	t_{rCL1}	$T_A = +25^\circ C$	10		80	ns
SCL Fall Time	t_{fCL}	$T_A = +25^\circ C$	10		40	ns
SDA Rise Time	t_{rDA}	$T_A = +25^\circ C$	10		80	ns
SDA Fall Time	t_{fDA}	$T_A = +25^\circ C$	10		80	ns
Setup Time for STOP Condition	t_{SU_STO}		160			ns
Bus Capacitance	C_B				100	pF
Pulse Width of Suppressed Spikes	t_{SP}	Maximum pulse width of spikes that must be suppressed by the input filter		10		ns
I²C COMPATIBLE INTERFACE TIMING (HIGH-SPEED MODE, $C_B = 400pF$) (Note 5)						
Clock Frequency	f_{SCL}				1.7	MHz
Setup Time REPEATED START Condition	t_{SU_STA}		160			ns
Hold Time (REPEATED) START Condition	t_{HD_STA}		160			ns
SCL Low Period	t_{LOW}		320			ns
SCL High Period	t_{HIGH}		120			ns
Data Setup Time	t_{SU_DAT}		10			ns
Data Hold Time	t_{HD_DAT}		0		150	ns
SCL Rise Time	t_{rCL}	$T_A = +25^\circ C$	20		80	ns
Rise Time of SCL Signal After REPEATED START Condition and After Acknowledge Bit	t_{rCL1}	$T_A = +25^\circ C$	20		80	ns
SCL Fall Time	t_{fCL}	$T_A = +25^\circ C$	20		80	ns
SDA Rise Time	t_{rDA}	$T_A = +25^\circ C$	20		160	ns
SDA Fall Time	t_{fDA}	$T_A = +25^\circ C$	20		160	ns
Setup Time for STOP Condition	t_{SU_STO}		160			ns
Bus Capacitance	C_B				400	pF
Pulse Width of Suppressed Spikes	t_{SP}	Maximum pulse width of spikes that must be suppressed by the input filter		10		ns

Note 5: Design guidance only. Not production tested.

Typical Operating Characteristics

(Typical Applications Circuit. $V_{SYSVA} = 3.7V$, $V_{IO} = 1.8V$, $T_A = +25^\circ C$, unless otherwise noted. Inductor = DFE201612E-1R5M, 1.5 μH , 72m Ω)

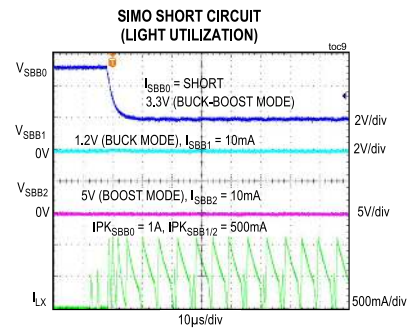
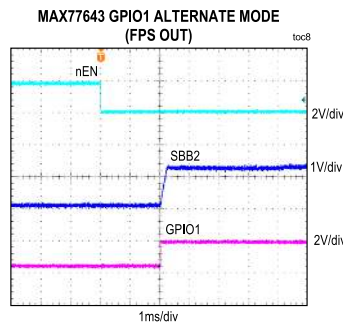
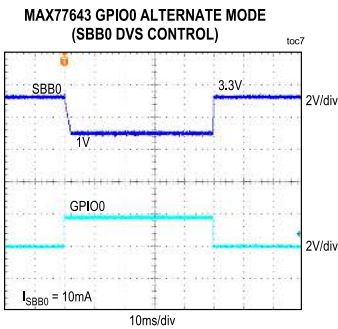
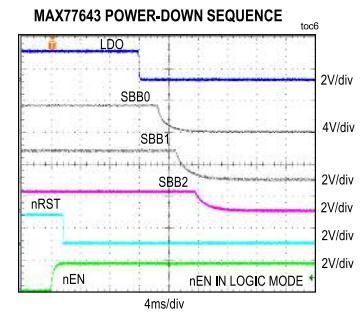
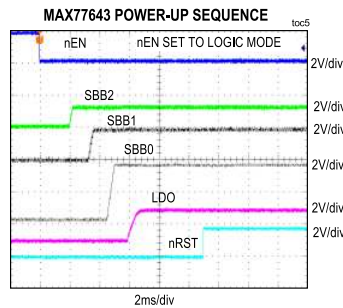
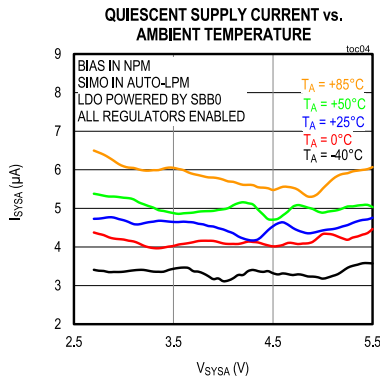
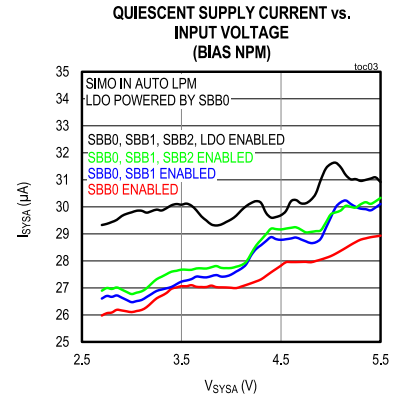
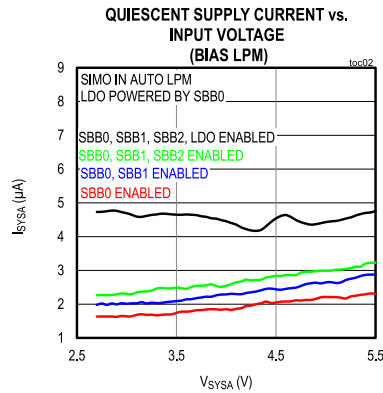
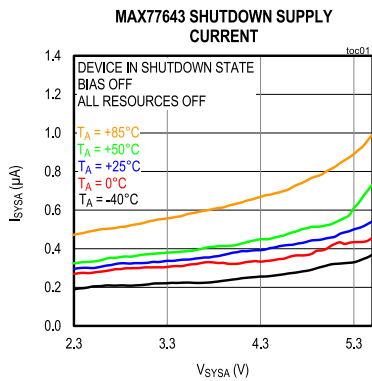

Typical Operating Characteristics (continued)

(Typical Applications Circuit. $V_{SYS} = 3.7V$, $V_{IO} = 1.8V$, $T_A = +25^\circ C$, unless otherwise noted. Inductor = DFE201612E-1R5M, 1.5 μH , 72m Ω)

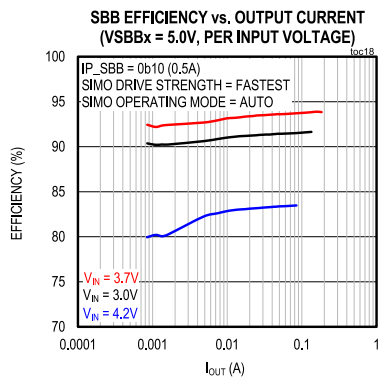
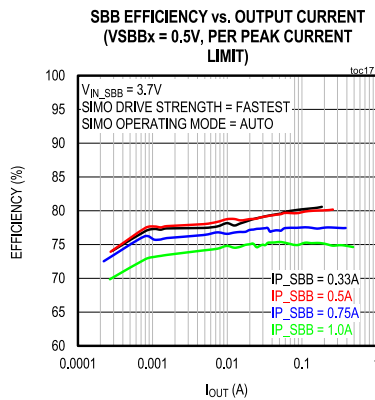
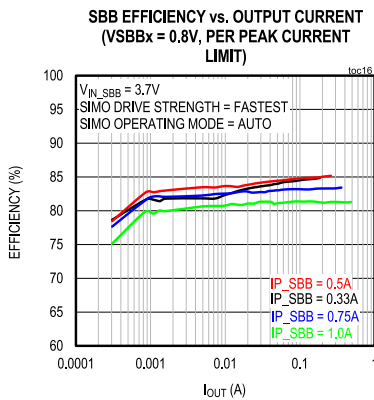
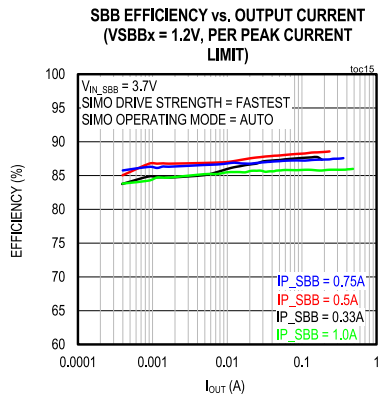
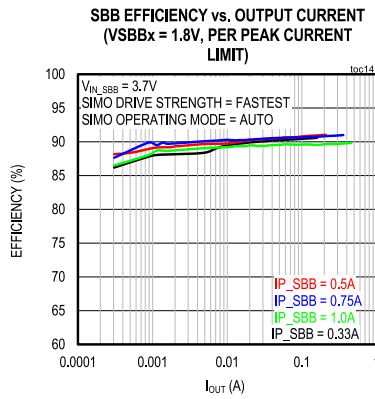
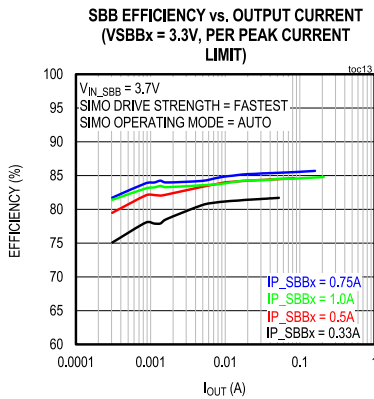
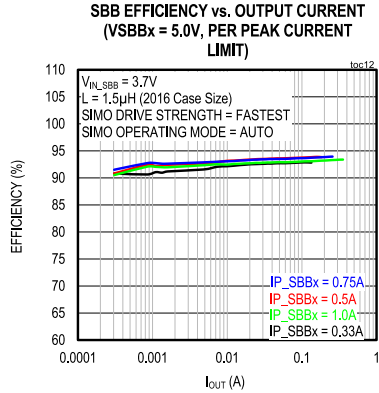
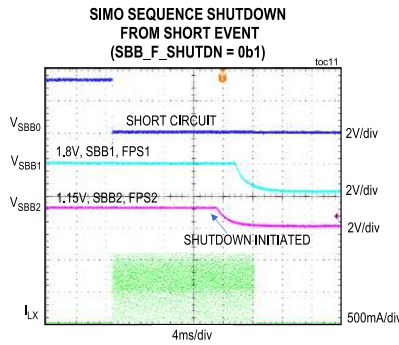
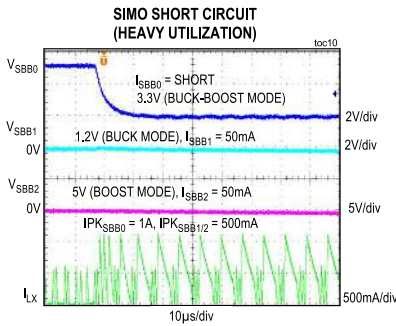

Typical Operating Characteristics (continued)

(Typical Applications Circuit. $V_{SYS A} = 3.7V$, $V_{IO} = 1.8V$, $T_A = +25^{\circ}C$, unless otherwise noted. Inductor = DFE201612E-1R5M, 1.5 μH , 72m Ω)

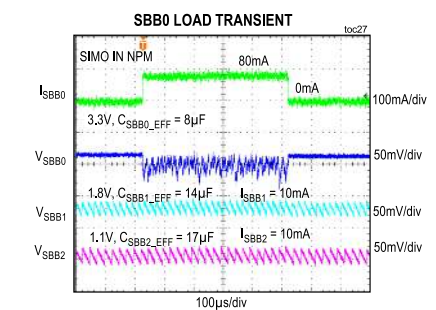
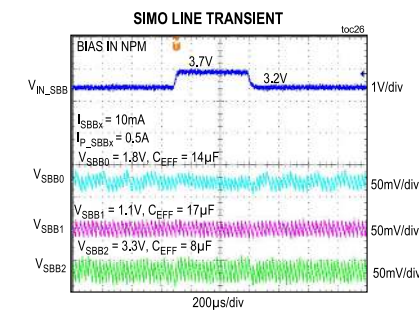
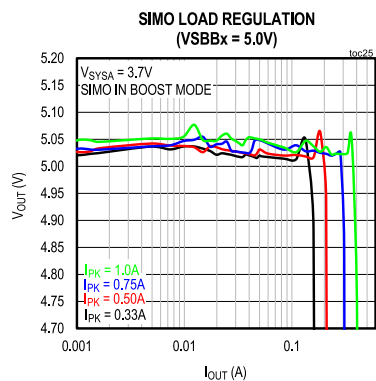
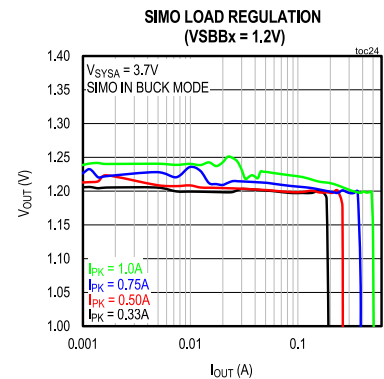
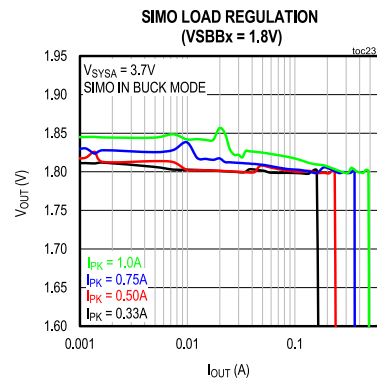
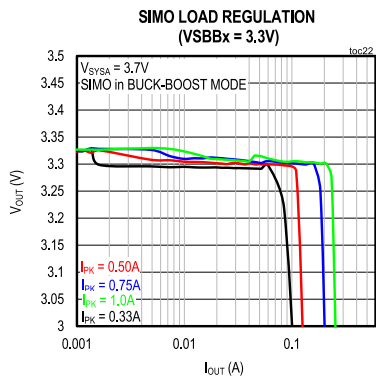
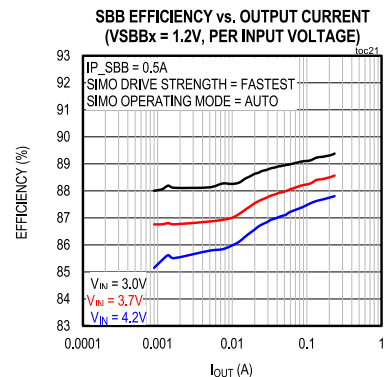
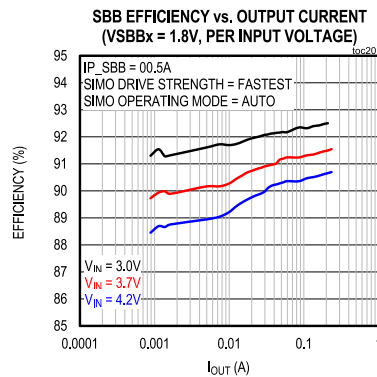
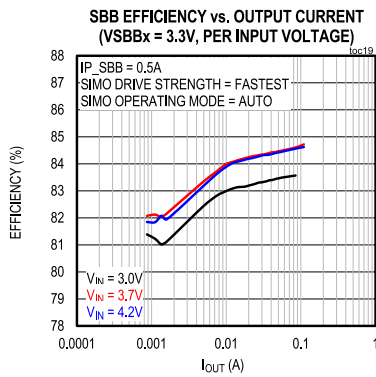

Typical Operating Characteristics (continued)

(Typical Applications Circuit. $V_{SYS} = 3.7V$, $V_{IO} = 1.8V$, $T_A = +25^{\circ}C$, unless otherwise noted. Inductor = DFE201612E-1R5M, $1.5\mu H$, $72m\Omega$)

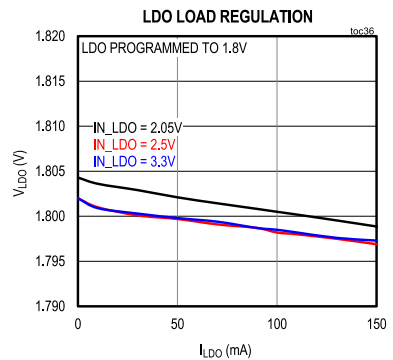
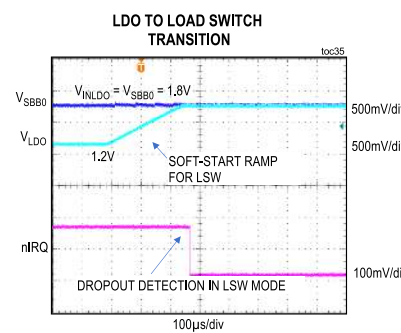
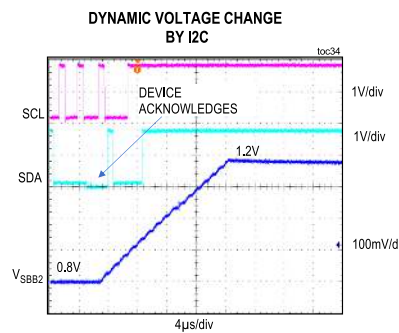
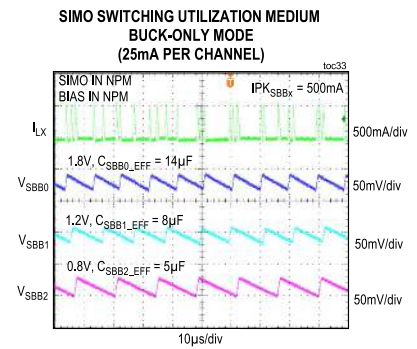
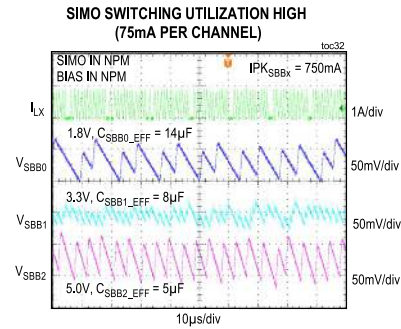
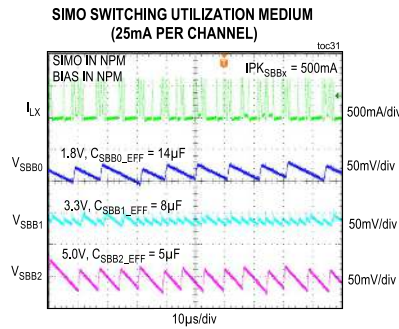
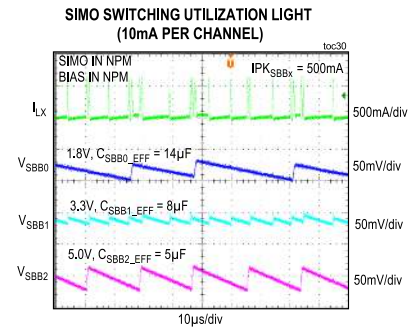
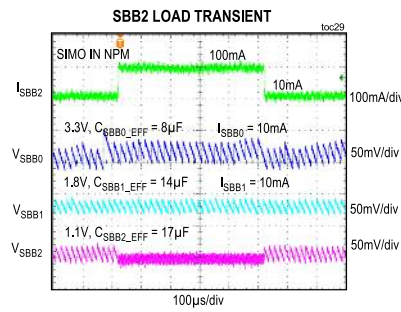
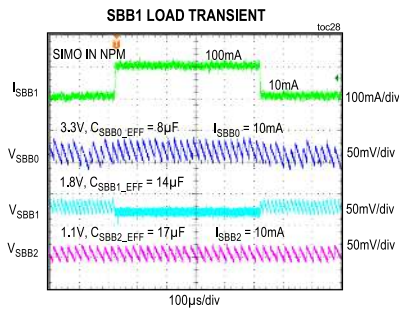

Typical Operating Characteristics (continued)

(Typical Applications Circuit. $V_{SYS_A} = 3.7V$, $V_{IO} = 1.8V$, $T_A = +25^\circ C$, unless otherwise noted. Inductor = DFE201612E-1R5M, 1.5 μH , 72m Ω)

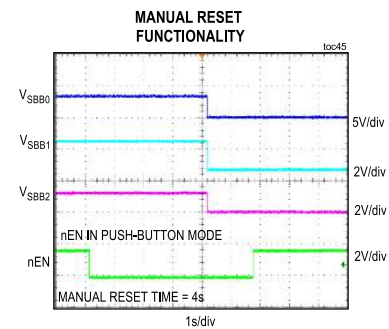
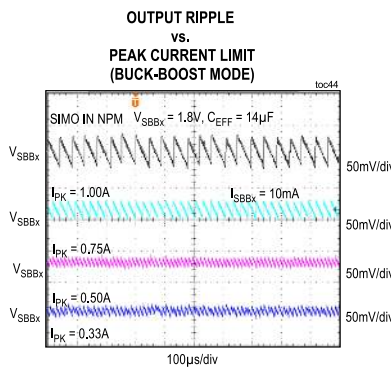
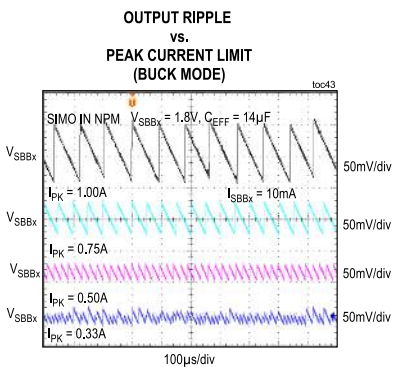
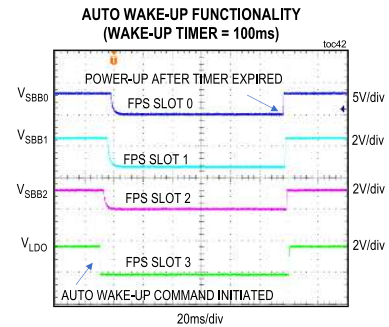
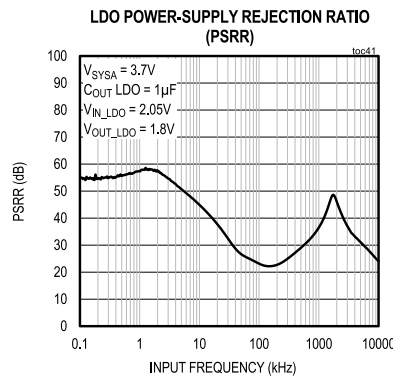
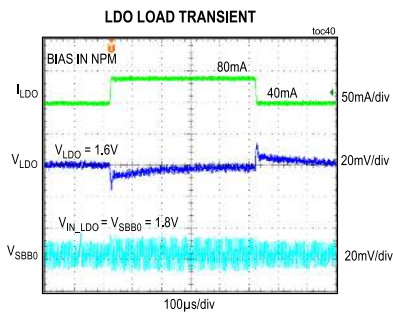
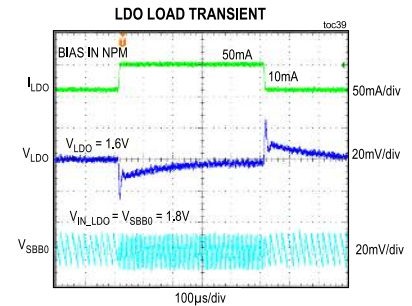
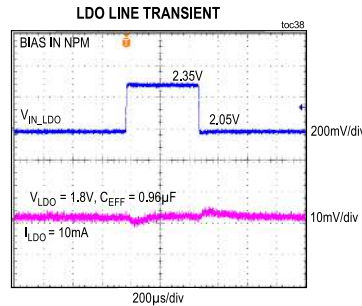
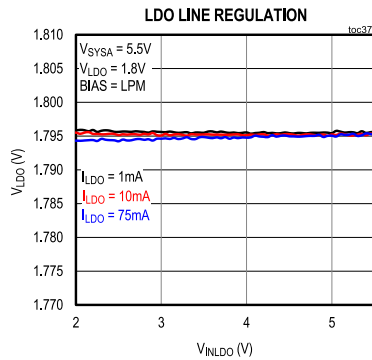

Pin Configurations

MAX77642

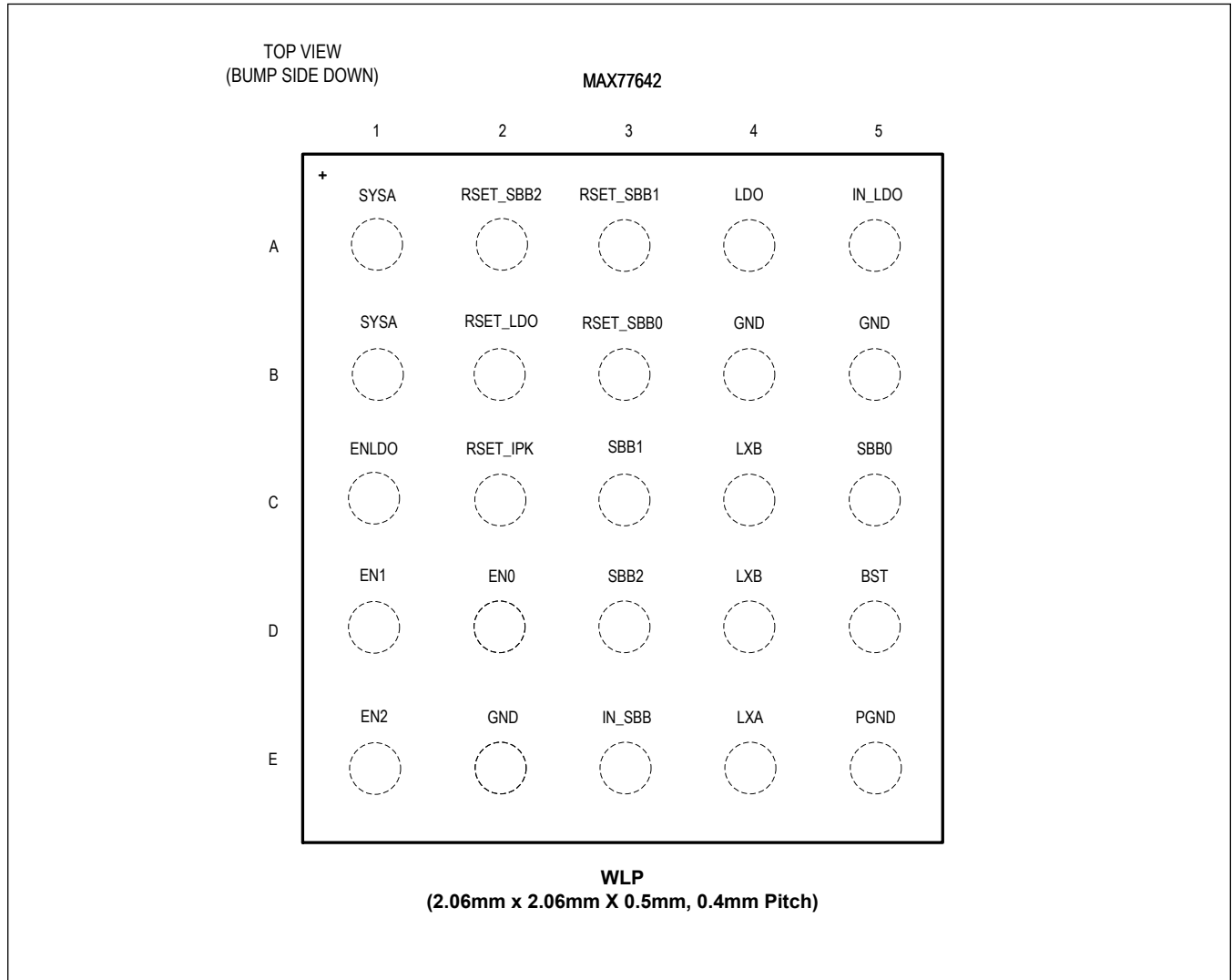

MAX77642/MAX77643

Ultra Configurable PMIC Featuring 93% Peak Efficiency Single-Inductor, 3-Output Buck-Boost, 1-LDO for Long Battery Life Applications

MAX77643

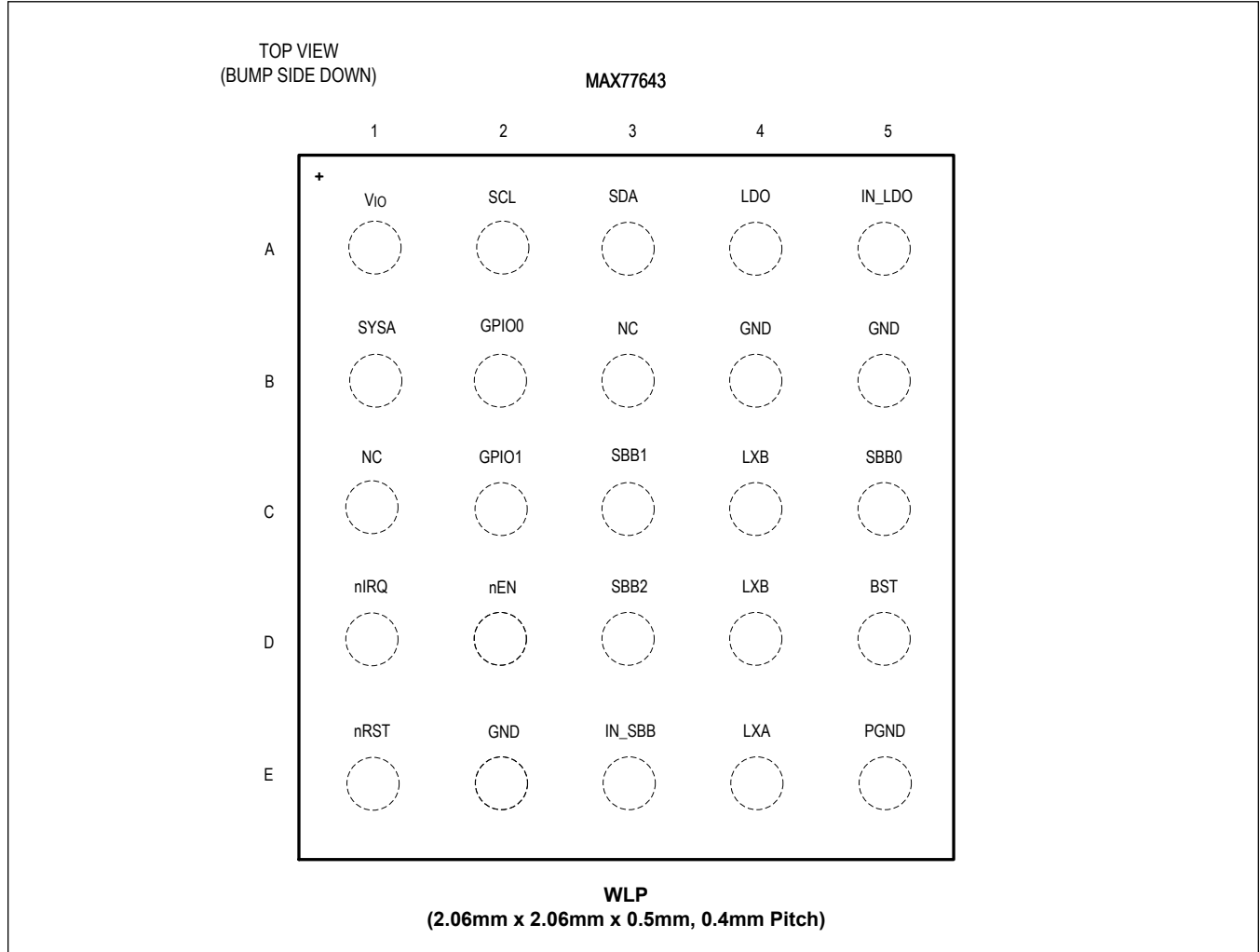

Pin Description

PIN		NAME	FUNCTION	TYPE
MAX77642	MAX77643			
TOP LEVEL				
—	A1	V _{IO}	I ² C Interface and GPIO Driver Power	Power Input
—	D2	nEN	Active-Low Enable Input. $\overline{\text{EN}}$ supports push-button or slide-switch configurations. If not used, connect nEN to SYS and use the CNFG_SBBx_B.EN_SBBx[2:0] and CNFG_LDO_B.EN_LDO[2:0] bitfields to enable channels.	Digital Input
—	D1	nIRQ	Active-Low, Open-Drain Interrupt Output. Connect a 100kΩ pullup resistor between IRQ and a voltage equal to or less than V _{SYSA} .	Digital Output
—	E1	nRST	Active-Low, Open-Drain Reset Output. Connect a 100kΩ pullup resistor between nRST and a voltage equal to or less than V _{SYSA} .	Digital Output
—	C2	GPIO1	General Purpose Input/Output. The GPIO I/O stage is internally biased with V _{IO} .	Digital I/O
—	B2	GPIO0	General Purpose Input/Output. The GPIO I/O stage is internally biased with V _{IO} .	Digital I/O
—	A2	SCL	I ² C Clock	Digital Input
—	A3	SDA	I ² C Data	Digital I/O
B4, B5, E2	B4, B5, E2	GND	Quiet Ground. Connect GND to PGND, and the low-impedance ground plane of the PCB.	Ground
A2	—	RSET_SBB2	Select Resistor Pin SBB2. Connect a resistor from this pin to GND, using the value to configure the output voltage of SBB2.	Resistor Input
A3	—	RSET_SBB1	Select Resistor Pin SBB1. Connect a resistor from this pin to GND, using the value to configure the output voltage of SBB1.	Resistor Input
B3	—	RSET_SBB0	Select Resistor Pin SBB0. Connect a resistor from this pin to GND, using the value to configure the output voltage of SBB0.	Resistor Input
B2	—	RSET_LDO	Select Resistor Pin LDO. Connect a resistor from this pin to GND, using the value to configure the output voltage of LDO0.	Resistor Input
C2	—	RSET_IPK	Select Resistor Pin IPK. Connect a resistor from this pin to GND, using the value to configure the peak inductor current.	Resistor Input
D2	—	EN0	Enable Input for SBB0. Hold high to enable output regulation. Hold low to disable the output.	Digital Input
D1	—	EN1	Enable Input for SBB1. Hold high to enable output regulation. Hold low to disable the output.	Digital Input
E1	—	EN2	Enable Input for SBB2. Hold high to enable output regulation. Hold low to disable the output.	Digital Input
—	C1, B3	NC	Not Connected	No Connect
C1	—	ENLDO	Enable Input for LDO. Hold high to enable output regulation. Hold low to disable the output.	Digital Input
SIMO BUCK-BOOST				
C5	C5	SBB0	SIMO Buck-Boost Output 0. SBB0 is the power output for channel 0 of the SIMO buck-boost. Bypass SBB0 to PGND with a 10μF ceramic capacitor. If not used, see the Unused Outputs section.	Power Output
C3	C3	SBB1	SIMO Buck-Boost Output 1. SBB1 is the power output for channel 1 of the SIMO buck-boost. Bypass SBB1 to PGND with a 10μF ceramic capacitor. If not used, see the Unused Outputs section.	Power Output

Pin Description (continued)

PIN		NAME	FUNCTION	TYPE
MAX77642	MAX77643			
D3	D3	SBB2	SIMO Buck-Boost Output 2. SBB2 is the power output for channel 2 of the SIMO buck-boost. Bypass SBB0 to PGND with a 10 μ F ceramic capacitor. If not used, see the Unused Outputs section.	Power Output
D5	D5	BST	SIMO Power Input for the High-Side Output NMOS Drivers. Connect a 10nF ceramic capacitor between BST and LXB.	Power Input
C4, D4	C4, D4	LXB	Switching Node B. LXB is driven between PGND and SBBx when SBBx is enabled. LXB is driven to PGND when all SIMO channels are disabled. Connect a 1.5 μ H inductor between LXA and LXB.	Power Input
E4	E4	LXA	Switching Node A. LXA is driven between PGND and IN_SBB when any SIMO channel is enabled. LXA is driven to PGND when all SIMO channels are disabled. Connect a 1.5 μ H inductor between LXA and LXB.	Power I/O
E5	E5	PGND	Power Ground for the SIMO Low-Side FETs. Connect PGND to GND, and the low-impedance ground plane of the PCB.	Ground
A1, B1	B1	SYSA	Analog Input Supply. Connect to V _{IN_SBB} .	Power Input
E3	E3	IN_SBB	SIMO Power Input. Connect IN_SBB to SYSA and bypass to PGND with a minimum of 10 μ F ceramic capacitor as close as possible to the IN_SBB pin.	Power Input
LDO				
A5	A5	IN_LDO	Linear Regulator Input. If connected to a SIMO output with a short trace, IN_LDO can share the output's capacitor. Otherwise, bypass with a 2.2 μ F ceramic capacitor to ground. If not used, connect to ground or leave unconnected.	Power Input
A4	A4	LDO	Linear Regulator Output. Bypass with a 1.0 μ F ceramic capacitor to GND. If not used, disable LDO and connect this pin to ground or leave unconnected.	Power Output

Detailed Description

The MAX77642/MAX77643 provide highly-integrated power management solutions for low-power applications.

Four regulators are integrated within this device (see [Table 1](#)). A single-inductor, multiple output (SIMO) buck-boost regulator efficiently provides three independently programmable power rails. A 150mA low-dropout linear regulator (LDO) provides ripple rejection for audio and other noise sensitive applications.

The MAX77643 includes other features such as two GPIOs with alternate modes for various system requirements. A bidirectional I²C serial interface allows for configuring and checking the status of the device. An internal on/off controller provides regulator sequencing and supervisory functionality for the device.

Table 1. Regulator Summary

REGULATOR NAME	REGULATOR TOPOLOGY	MAXIMUM I _{OUT} (mA)	V _{IN} RANGE (V)	MAX77643 V _{OUT} RANGE/ RESOLUTION
SBB0	SIMO	Up to 500*	2.7 to 5.5	0.5V to 5.5V in 25mV steps
SBB1	SIMO		2.7 to 5.5	0.5V to 5.5V in 25mV steps
SBB2	SIMO		2.7 to 5.5	0.5V to 5.5V in 25mV steps
LDO	PMOS LDO	150	1.7 to 5.5	0.5V to 5.0V in 25mV steps

*Shared capacity with other SBBx channels. See the [SIMO Available Output Current](#) section for more information.

Part Number Decoding

The MAX77643 has different one-time programmable (OTP) options and variants to support a variety of applications. The OTP options set default settings such as output voltage. Variants are versions of the MAX77643 with different features. See [Figure 1](#) for how to identify these. [Table 2](#) and [Table 3](#) list all available OTP options and variants. Refer to [Maxim Products Naming Convention](#) for more details.

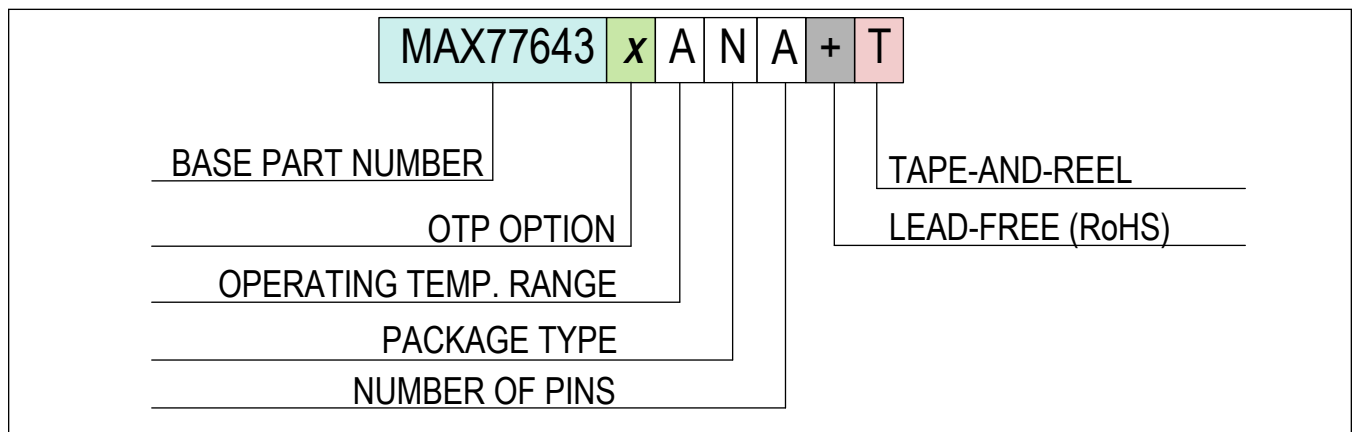

Figure 1. Part Number Decode

Table 2. Variants Table

PART NUMBER	MAX77642	MAX77643
Resistor Programmable Output Voltages	Yes	No
Resistor Programmable Peak Current	Yes	No
Supports LDO/LSW	Yes	Yes
Include GPIOs	No	Yes
Individual Enable Pins for LDO and SIMO Outputs	Yes	No

Table 2. Variants Table (continued)

PART NUMBER	MAX77642	MAX77643
Programmable Flexible Power Sequencer	No	Yes
Watchdog Timer	No	Yes
Supports I ² C Serial Communication	No	Yes

Table 3. OTP Options Table

BLOCK	BIT FIELD NAME	SETTING NAME	OTP LETTER AND SETTINGS					
			A	B	C	E	D	S
Global	PU_DIS	nEN Internal, Strong Pullup Disable	Weak (10MΩ)	Weak (10MΩ)	Weak (10MΩ)	Weak (10MΩ)	Weak (10MΩ)	Weak (10MΩ)
	MRST	Manual Reset Time	4s	4s	4s	4s	4s	4s
	SBIA_LPM	Bias Power Mode	Low-Power Mode	Low-Power Mode	Low-Power Mode	Low-Power Mode	Low-Power Mode	Low-Power Mode
	nEN_MODE	On-Key Default Configuration	Logic-Mode	Logic-Mode	Logic-Mode	Logic-Mode	Logic-Mode	Logic-Mode
	DBEN_nEN	Debounce Timer for nEN	500μs	500μs	500μs	500μs	500μs	500μs
	ALT_GPIO0	GPIO0 Mode	GPIO	GPIO	GPIO	GPIO	GPIO	Alt.
	ALT_GPIO1	GPIO1 Mode	GPIO	GPIO	GPIO	GPIO	GPIO	GPIO
	ADDR	I ² C Address (7-bit)	0x48	0x4C	0x44	0x40	0x48	0x48
	UVLO_F[3:0]	UVLO Falling	2.6V	2.6V	2.6V	2.6V	2.6V	2.6V
	UVLO_H[3:0]	UVLO Hysteresis	0.3V	0.3V	0.3V	0.3V	0.3V	0.3V
CID[4:0]	Chip ID	0x02	0x7	0x8	0x9	0xB	0x05	
Watchdog	WDT_LOCK	Watchdog Timer Disable Control	Unlocked	Unlocked	Unlocked	Unlocked	Unlocked	Unlocked
	WDT_EN	Watchdog Timer Enable	Disabled	Disabled	Disabled	Disabled	Disabled	Disabled
SIMO	TV_SBB0[7:0]	SBB0 V _{OUT}	3.050V	1.200V	1.200V	2.500V	3.050V	0.650V
	IP_SBB0[1:0]	SBB0 Inductor Current Peak Limit	0.750A	0.333A	0.333A	0.333A	0.750A	0.333A
	OP_MODE[1:0] (SBB0)	SBB0 Operating Mode	Buck-Boost	Buck	Buck	Buck	Buck	Buck-Boost
	ADE_SBB0	Active-Discharge Resistor Enable	Enabled	Enabled	Enabled	Enabled	Enabled	Enabled
	EN_SBB0[2:0]	SBB0 Enable Control	FPS Slot 0	Off	Off	Off	Off	FPS Slot 1
	TV_SBB1[7:0]	SBB1 V _{OUT}	1.800V	2.500V	2.500V	1.100V	1.800V	0.800V
	IP_SBB1[1:0]	SBB1 Inductor Current Peak Limit	0.333A	0.333A	0.333A	0.500A	0.333A	0.333A
	OP_MODE[1:0] (SBB1)	SBB1 Operating Mode	Buck-Boost	Buck	Buck	Buck	Buck-Boost	Buck
	ADE_SBB1	Active-Discharge Resistor Enable	Enabled	Enabled	Enabled	Enabled	Enabled	Enabled
	EN_SBB1[2:0]	SBB1 Enable Control	On	Off	Off	Off	On	FPS Slot 2
TV_SBB2[7:0]	SBB2 V _{OUT}	1.200V	1.500V	1.500V	1.500V	1.075V	1.800V	

Table 3. OTP Options Table (continued)

			OTP LETTER AND SETTINGS					
	IP_SBB2[1:0]	SBB2 Inductor Current Peak Limit	0.333A	0.333A	0.333A	0.333A	0.500A	0.333A
	OP_MODE[1:0] (SBB2)	SBB2 Operating Mode	Buck-Boost	Buck	Buck	Buck	Buck-Boost	Buck
	ADE_SBB2	Active-Discharge Resistor Enable	Enabled	Enabled	Enabled	Enabled	Enabled	Enabled
	EN_SBB2[2:0]	SBB2 Enable Control	FPS Slot 2	Off	Off	Off	Off	FPS Slot 0
LDO	TV_OFS_LDO	LDO V_{OUT} Offset	No Offset	No Offset	No Offset	No Offset	No Offset	No Offset
	TV_LDO[6:0]	LDO V_{OUT}	2.800V	1.800V	1.800V	1.800V	2.825V	1.800V
	LDO_MD	LDO or LSW Mode	LDO	LDO	LDO	LDO	LDO	LDO
	ADE_LDO	Active-Discharge Resistor Enable	Enabled	Enabled	Enabled	Enabled	Enabled	Enabled
	EN_LDO[2:0]	LDO Enable Control	FPS Slot 1	On	On	On	Off	FPS Slot 3

Detailed Description—Global Resources

The global resources encompass a set of circuits that serve the entire device and ensure safe, consistent, and reliable operation.

Features and Benefits

- Voltage Monitors
 - IN power-on-reset (POR) comparator generates a reset signal upon power-up
 - IN undervoltage ensures repeatable behavior when power is applied to and removed from the device
 - IN overvoltage monitor inhibits operation with overvoltage power sources to ensure reliability in faulty environments
- Thermal Monitors
 - +145°C junction temperature shutdown
- Manual Reset
 - 4s or 8s period
- Wake-Up Events
 - nEN input assertion
- Interrupt Handler
 - Interrupt output (nIRQ)
 - All interrupts are maskable
- Push-Button/Slide-Switch/Logic Mode On-Key (nEN)
 - Configurable push-button/slide-switch functionality
 - 500µs or 30ms debounce timer interfaces directly with mechanical switches
- On/Off Controller
 - Startup/shutdown sequencing
 - Programmable sequencing delay
- GPIO, nRST Digital I/Os

Voltage Monitors

The device monitors the system voltage (V_{SYS_A}) to ensure proper operation using three comparators (POR, UVLO, and OVLO). These comparators include hysteresis to prevent their outputs from toggling between states during noisy system transitions.

SYSA POR Comparator

The SYSA POR comparator monitors V_{SYS_A} and generates a power-on reset (POR) signal. When V_{SYS_A} is below V_{POR} , the device is held in reset ($SYSARST = 1$). When V_{SYS_A} rises above V_{POR} , internal signals and on-chip memory stabilize and the device is released from reset ($SYSRST = 0$).

SYSA Undervoltage-Lockout Comparator

The SYSA undervoltage-lockout (UVLO) comparator monitors V_{SYS_A} and generates a SYS_AUVLO signal when the V_{SYS_A} falls below UVLO threshold. The SYS_AUVLO signal is provided to the top-level digital controller. See [Figure 6](#), [Table 5](#), [Figure 7](#), and [Table 6](#) for additional information regarding the UVLO comparator.

SYSA Overvoltage-Lockout Comparator

The device is rated for 5.5V maximum operating voltage (V_{SYS_A}) with an absolute maximum input voltage of 6.0V. An overvoltage-lockout monitor increases the robustness of the device by inhibiting operation when the supply voltage is greater than V_{SYS_AOVLO} . See [Figure 6](#), [Table 5](#), [Figure 7](#), and [Table 6](#) for additional information regarding the OVLO comparator.

Thermal Monitors

The MAX77643 has three global on-chip thermal sensors:

- Junction Temperature Alarm 1 → 80°C
- Junction Temperature Alarm 2 → 100°C
- Junction Temperature Shutdown → 145°C

The junction temperature alarms have maskable rising interrupts as well as status bits (see the Register Map section for more information). Unmasking these thermal alarms is recommended for all systems. If the first alarm is triggered, the system software should attempt to lower system power dissipation. If the second alarm is triggered, then attempts to lower the power dissipation were unsuccessful and the system software should turn the device off. Finally, if the junction temperature rises to junction temperature shutdown, then the MAX77643 sets the ERCFLAG.TOVLD bit and automatically turns itself off.

After a junction temperature shutdown event, the system can be enabled again. The system software can read the ERCFLAG register during initialization to see ERCFLAG.TOVLD = 1 and log that an extreme thermal event has occurred.

Chip Identification

The MAX77643 offers different one-time-programmable (OTP) options to, for example, set the default output voltages. These options are identified by the chip identification number, which can be read in the CID register.

nEN Enable Input (MAX77643)

The nEN is an active-low internally debounced digital input that typically comes from the system's on-key. The debounce time is programmable with CNFG_GLBLx.DBEN_nEN. The primary purpose of this input is to generate a wake-up signal for the PMIC that turns on the regulators. Maskable rising/falling interrupts are available for nEN (INT_GLBLx.nEN_R and INT_GLBLx.nEN_F) for alternate functionality.

The nEN input can be configured to work either with a push-button (CNFG_GLBL0.nEN_MODE = 0b00), a slide-switch (CNFG_GLBL0.nEN_MODE = 0b01), or Logic Mode (CNFG_GLBL0.nEN_MODE = 0b10). See [Figure 3](#) for more information. In both push-button mode and slide-switch mode, the on/off controller looks for a falling edge on the nEN input to initiate a power-up sequence.

EN Enable Input (MAX77642)

The MAX77642 features three enable pins to individually control the on/off state of the SIMO outputs. Drive each enable pin high to turn its respective SIMO output on. Each enable pin has a 50nA pulldown current to ground (as shown in [Figure 2](#)). The pins can be tied high for always on-applications. Do not leave the EN pins unconnected.

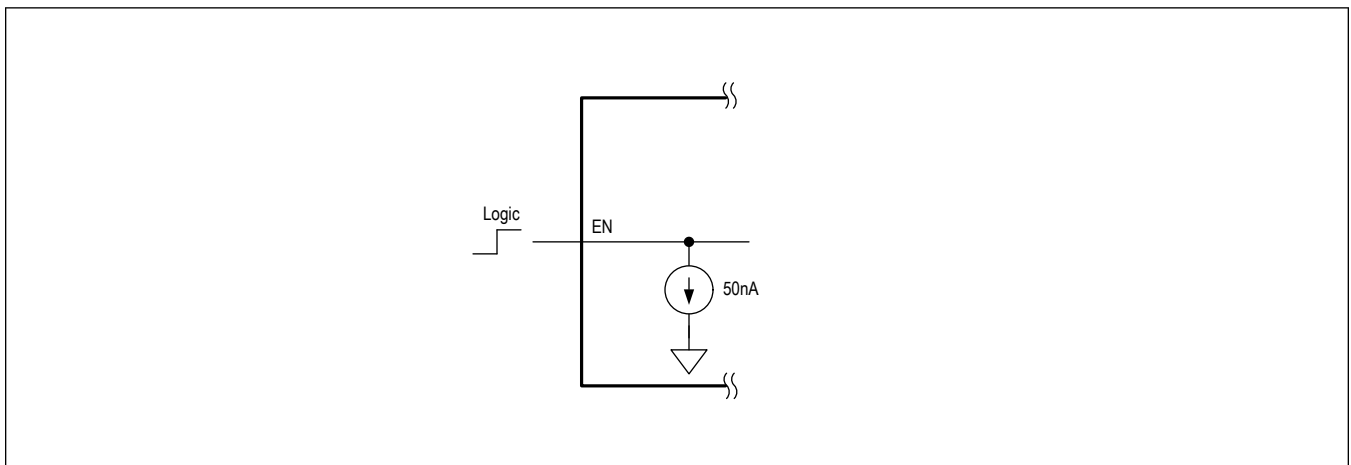

Figure 2. EN Pulldown

nEN Manual Reset (MAX77643)

The nEN works as a manual reset input when the on/off controller is in the "Resource-On" state. The manual reset function is useful for forcing a power-down in case communication with the processor fails. When nEN is configured for

push-button mode and the input is asserted (nEN = LOW) for an extended period (t_{MRST}), the on/off controller initiates a power-down sequence and goes to shutdown mode. When nEN is configured for slide-switch mode and the input is deasserted (nEN = HIGH) for an extended period (t_{MRST}), the on/off controller initiates a power-down sequence and goes to standby mode. When nEN is configured as a logic mode, the on/off controller initiates a power-up sequence and goes into Resource ON mode when the input is asserted (nEN = LOW). When the input is deasserted (nEN = HIGH), the on/off controller initiates a power-down sequence and goes into shutdown mode.

nEN Triple-Functionality: Push-Button vs. Slide-Switch vs. Logic (MAX77643)

The nEN digital input can be configured to work with a push-button, a slide-switch, or a logic input. Figure 3 shows nEN's triple mode functionality for power-on sequencing and manual reset. The default configuration of the device is push-button mode (CNFG_GLBL0.nEN_MODE = 0b00) and no additional programming is necessary. Applications that use a slide-switch on-key and logic configuration must set CNFG_GLBL0.nEN_MODE = 0b01 and CNFG_GLBL0.nEN_MODE = 0b10 respectively within t_{MRST} .

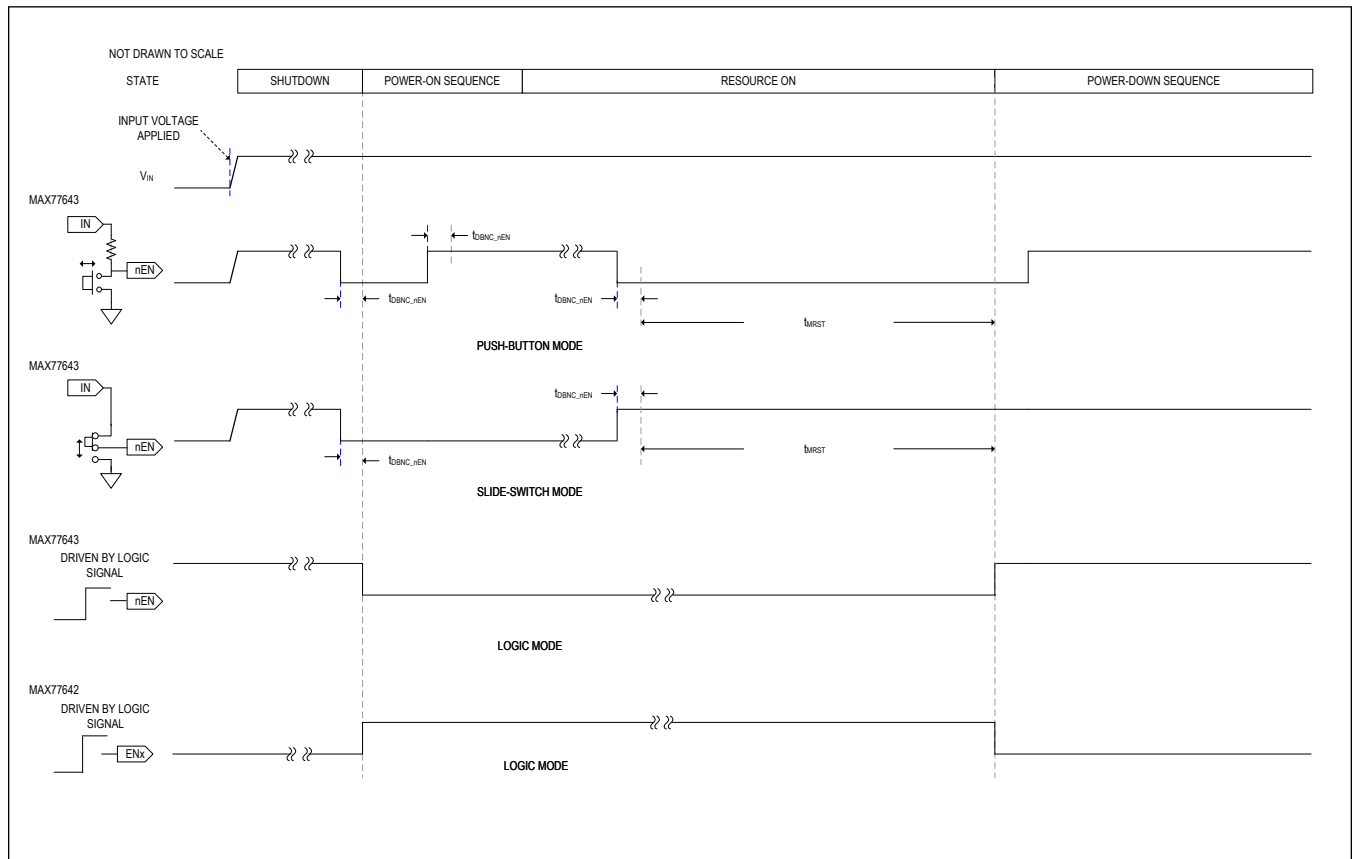

Figure 3. nEN Usage Timing Diagram

nEN Internal Pullup Resistors to V_{SYSA}

The nEN logic thresholds are referenced to V_{SYSA}. There are internal pullup resistors between nEN and V_{SYSA} (R_{nEN_PU}), which can be configured with the CNFG_GLBL0.PU_DIS bit. See [Figure 4](#). While PU_DIS = 0, the pullup value is approximately 200kΩ. While PU_DIS = 1, the pullup value is 10MΩ.

Applications using a slide-switch on-key or push-pull digital output connected to nEN can reduce quiescent current consumption by changing pullup strength to 10MΩ. Applications using normally-open, momentary, and push-button on-keys (as shown in [Figure 4](#)) do not create this leakage path and should use the stronger 200kΩ pullup option.

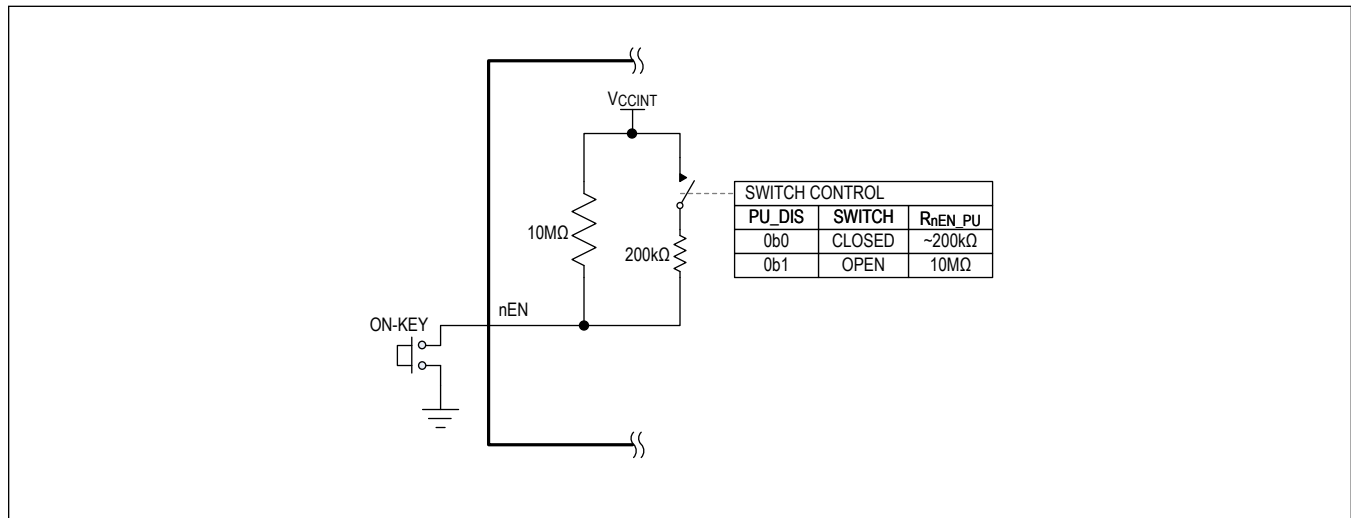

Figure 4. nEN Pullup Resistor Configuration

Interrupts (nIRQ) (MAX77643)

The nIRQ (MAX77643) is an active-low, open-drain output that is typically routed to the host processor's interrupt input to signal an important change in device status. See the *Register Map* section for a comprehensive list of all interrupt bits and status registers.

A pullup resistor to a voltage less than or equal to V_{SYSA} is required for this node. The nIRQ is the logical NOR of all unmasked interrupt bits in the register map.

All interrupts are masked by default. Masked interrupt bits do not cause the nIRQ pin to change. Unmask the interrupt bits to allow the nIRQ to assert.

Reset Output (nRST) (MAX77643)

The nRST (MAX77643) is an open-drain, active-low output that is typically used to hold the processor in a reset state when the device is powered down. During a power-up sequence, the nRST deasserts after the last regulator in the power-up chain is enabled (t_{RSTODD}). During a power-down sequence, the nRST output asserts before any regulator is powered down (t_{RSTOAD}). See [Figure 11](#) for nRST timing.

A pullup resistor to a voltage less than or equal to V_{SYSA} is required for this node.

General-Purpose Input Output (GPIO) (MAX77643)

The MAX77643 provides two general-purpose input/output (GPIO) pins increase system flexibility. See [Figure 5](#) for more details.

Clear CNFG_GPIOx.DIR = 0b0 to configure GPIO as a general-purpose output (GPO). The GPO can either be in push-pull mode (CNFG_GPIOx.DRV = 1) or open-drain mode (CNFG_GPIOx.DRV = 0).

- The push-pull output mode is ideal for applications that need fast (~2ns) edges and low power consumption.
- The open-drain mode requires an external pullup resistor (typically 10kΩ to 100kΩ). Connect the external pullup resistor to a bias voltage that is less than or equal to V_{IO} .
 - The open-drain mode can be used to communicate to different logic domains. For example, to send a signal from the GPO on a 1.8V logic domain ($V_{IO} = 1.8V$) to a device on a 1.2V logic domain, connect the external pullup resistor to 1.2V.
 - The open-drain mode can be used to connect several open-drain (or open-collector) devices together on the same bus to create wired logic (wired AND logic is positive-true; wired OR logic is negative-true).
- The general-purpose input (GPI) functions are still available while the pin is configured as a GPO. In other words, the CNFG_GPIOx.DI (input status) bit still functions and does not collide with the state of the CNFG_GPIOx.DIR bit.

Set CNFG_GPIOx.DIR to have the GPIO function as a GPI. The GPI features a 30ms debounce timer (t_{DBNC_GPI}) that can be enabled or disabled with DBEN_GPI.

- Enable the debounce timer (CNFG_GPIOx.DBEN_GPI = 1) if the GPI is connected to a device that can bounce or chatter, like a mechanical switch.
- If the GPI is connected to a circuit with clean logic transitions and no risk of bounce, disable the debounce timer (CNFG_GPIOx.DBEN_GPI = 0) to eliminate logic delays. With no debounce timer, the GPI input logic propagates to nIRQ in 10ns.

A dedicated internal oscillator is used to create the 30ms (t_{DBNC_GPI}) debounce timer. To obtain low V_{IO} supply current, ensure the GPIO voltage is either logic high or logic low. If the GPIO pin is unconnected (either as a GPI or an open-drain GPO) and V_{IO} is powered, the GPIO voltage trends towards the logic level gray area ($0.3 \times V_{IO} < V_{GPIO} < 0.7 \times V_{IO}$). If V_{GPIO} is in the gray area, V_{IO} current can be more than 10μA.

The GPI features edge detectors that feed into the the top-level interrupt system of the chip. This allows software to use interrupts to service events associated with a GPI change instead of polling for these changes.

- If the application wants nIRQ to go low **only on a GPI rising edge**, then it should **clear** the GPI rising edge interrupt mask bit (INTM_GLBLx.GPI_RM = 0) and **set** the GPI falling edge interrupt mask bit (INTM_GLBLx.GPI_FM = 1).
- If the application wants nIRQ to go low **only on a GPI falling edge**, then it should **set** the GPI rising edge interrupt mask bit (INTM_GLBLx.GPI_RM = 1) and **clear** the GPI falling edge interrupt mask bit (INTM_GLBLx.GPI_FM = 0).
- If the application wants nIRQ to go low **on both GPI falling and rising edges**, then it should **clear** the GPI rising edge interrupt mask bit (INTM_GLBLx.GPI_RM = 0) and **clear** the GPI falling edge interrupt mask bit (INTM_GLBLx.GPI_FM = 0).

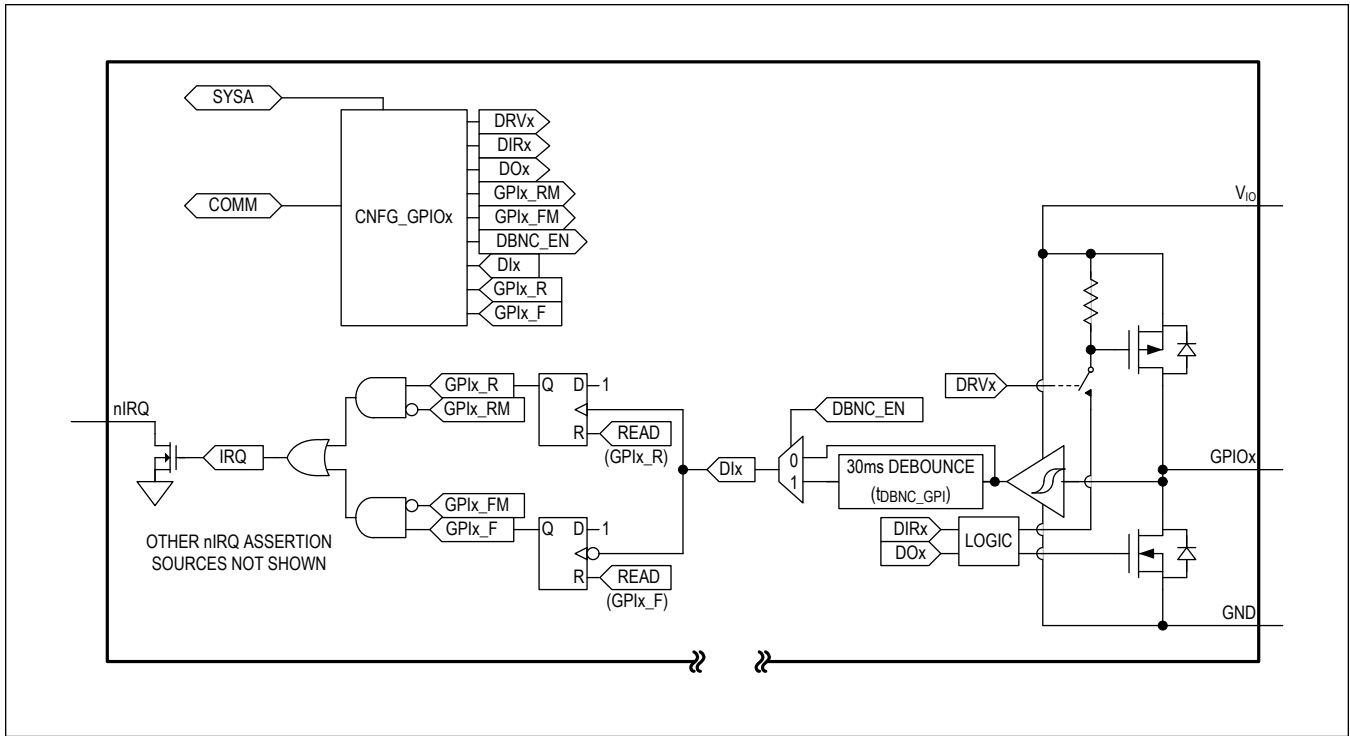

Figure 5. GPIOx Block Diagram

Alternate Mode (MAX77643)

The GPIO in the MAX77643 can be configured to have a different function. Whether the GPIO is in GPIO mode or alternate mode can be checked by reading the CNFG_GPIOx.ALT_GPIOx bit. [Table 4](#) summarizes the alternate functions for each GPIO.

Table 4. GPIO MODE

GPIOx	CNFG_GPIOx REGISTER	
	ALT_GPIOx = 0	ALT_GPIOx = 1
GPIO0	Standard GPIO	Active-high input, controls the DVS feature for SBB0.
GPIO1	Standard GPIO	Active-high output of SBB2's flexible power sequencer (FPS) slot.

On/Off Controller

The on/off controller monitors multiple power-up (wake-up) and power-down (shutdown) conditions to enable or disable resources that are necessary for the system and its processor to move between its operating modes.

Many systems have one power management controller and one processor and rely on the on/off controller to be the master controller. In this case, the on/off controller receives wake-up events and enables some or all of the regulators to power up a processor. That processor then manages the system. To conceptualize this master operation, see [Figure 7](#) and [Table 6](#). A typical path through the on/off controller is:

1. Apply a battery and start in the shutdown state.
2. Press the system's on-key (nEN = LOW) and follow transitions 3 and 4 to the resource-on state. If any resources are on the FPS, transitions 5A and 5B are followed.
3. The device performs its desired functions in the resource-on state. when it is ready to turn off, a manual reset first drives the transition through transitions 6A and 6B for FPS power down then through the 7 and 0 states to the shutdown state.

Some systems have several power management blocks, a main processor, and subprocessors. These systems can use this device as a subpower management block for a peripheral portion of circuitry as long as there is an I²C port available from a higher level processor. To conceptualize this operation, see [Figure 7](#) and [Table 6](#). A typical path through the on/off controller used in this way is:

1. Apply a battery to the system and start in the shutdown state.
2. The higher level processor can now control this device's resources with I²C commands (e.g., turn on/off regulators).
3. When the higher level processor is ready to turn this device off, it turns off everything through I²C to transition along path 7 to the shutdown state.

Note that in this style of operation, the CNFG_GLBL0.SFT_CTRL[1:0] bits should not be used to turn the device off. The CNFG_GLBL0.SFT_CTRL[1:0] bits establish directives to the on/off controller itself that does not make sense in this subpower management block operation. If the processor uses I²C commands to enable the device's resources, the processor should also use I²C commands to disable them.

Top Level On/Off Controller (MAX77642)

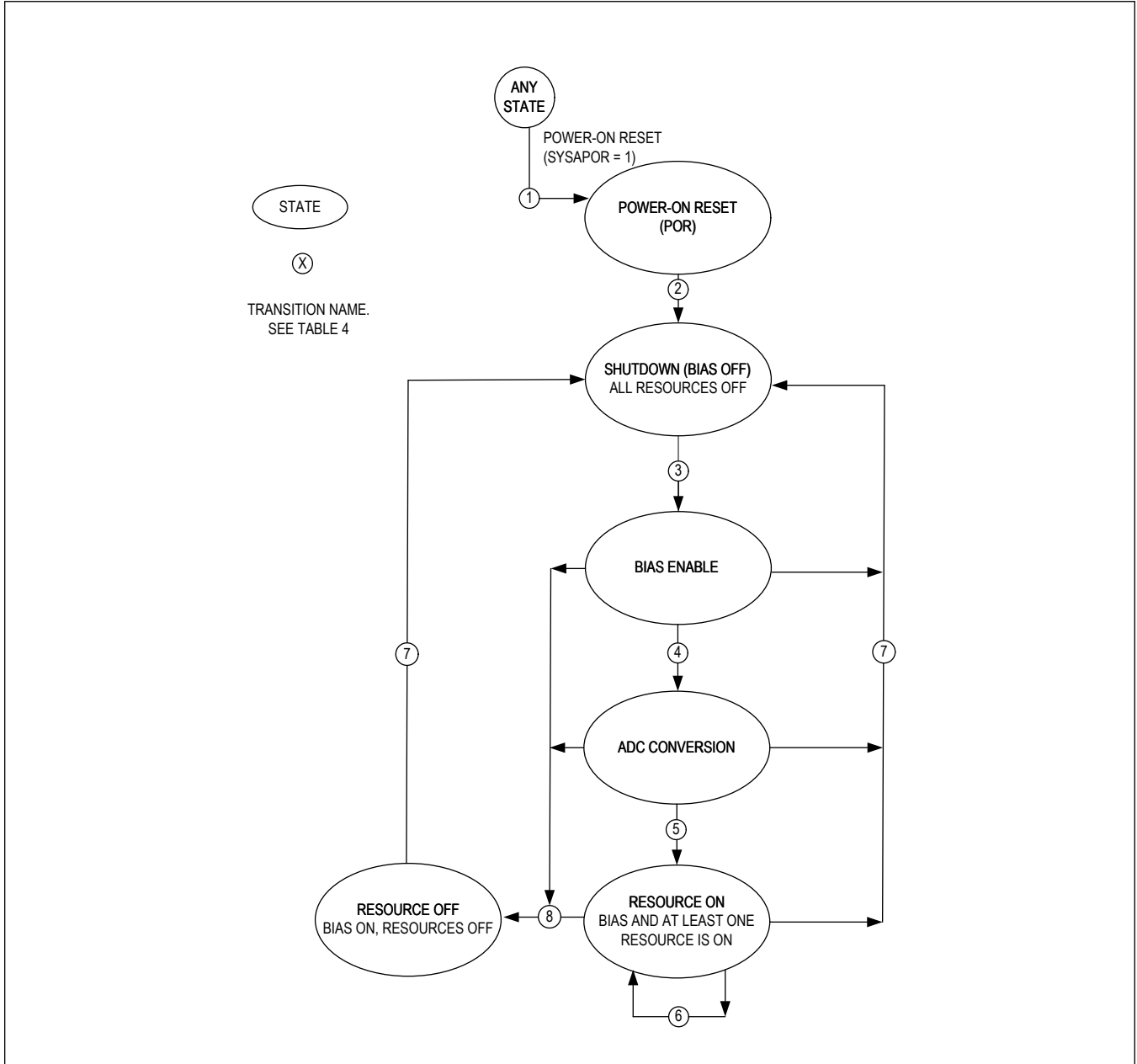

Figure 6. Top Level On/Off Controller State Diagram (MAX77642)

On/Off Controller Transition Table (MAX77642)**Table 5. On/Off Controller Transition/State (MAX77642)**

TRANSITION	CONDITION (TRANSITION HAPPENS WHEN...)
1	System voltage is above the POR threshold ($V_{SYS} > V_{POR}$)
2	$V_{SYS} \geq V_{SYS(UVLO_R)}$
3	First ENx transitions from low to high
4	Main Bias enable time expires (t_{SBIAEN})
5	ADC detection time expires (t_{RSET})
6	Additional ENx transitions from low to high OR ENx transitions from high to low (as long as one SIMO channel or the LDO is enabled)
7	Last ENx transitions from high to low (all SIMO channels and the LDO are disabled)
8	Chip overtemperature lockout ($T_J > T_{OTLO}$) OR SYS A undervoltage lockout ($V_{SYS} < V_{SYS(UVLO)}$) OR SYS A overvoltage lockout ($V_{SYS} > V_{SYS(OVLO)}$)

Top Level On/Off Controller (MAX77643)

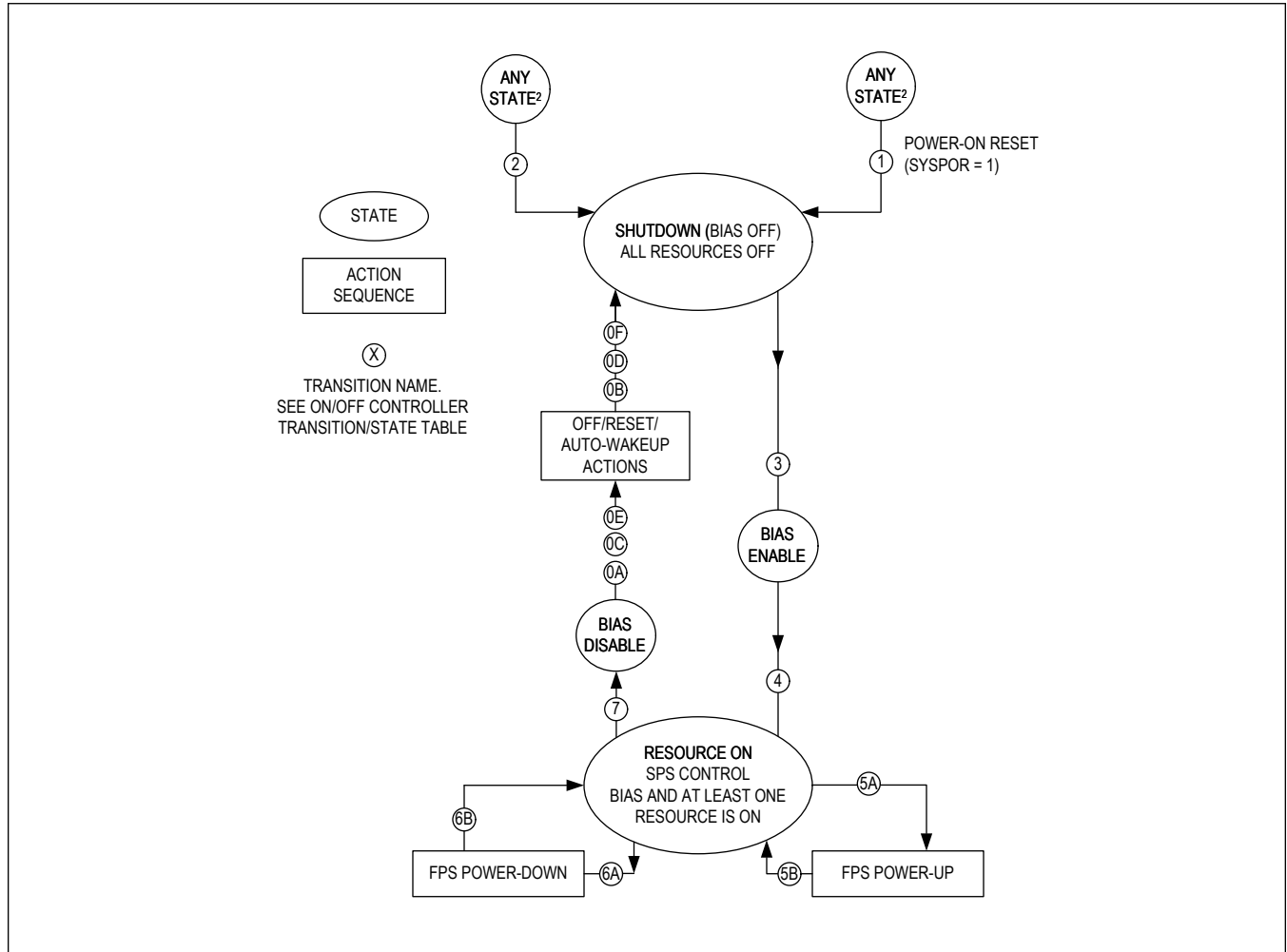

Figure 7. Top Level On/Off Controller State Diagram (MAX77643)

On/Off Controller Transition Table (MAX77643)**Table 6. On/Off Controller Transition/State (MAX77643)**

TRANSITION	CONDITION (TRANSITION HAPPENS WHEN...)
0A	Software cold reset (CNFG_GLBL0.SFT_CTRL[1:0] = 0b01) OR Watchdog timer expired and caused reset (ERCFLAG.WDT_RST = 1, CNFG_WDT.WDT_MODE = 1)
0B	Reset actions completed
0C	Software power-off (CNFG_GLBL0.SFT_CTRL[1:0] = 0b10) OR Watchdog expired and caused power-off (ERCFLAG.WDT_OFF = 1, CNFG_WDT.WDT_MODE = 0) OR Chip overtemperature lockout ($T_J > T_{OTLO}$) OR SYSA undervoltage lockout ($V_{SYSA} < V_{SYSAUVLO} + V_{SYSAUVLO_HYS}$) OR SYSA overvoltage lockout ($V_{SYSA} > V_{SYSAOVLO}$) OR Manual reset occurred (ERCFLAG.MRST = 1)
0D	Off actions completed
0E	Software auto wake-up (CNFG_GLBL0.SFT_CTRL = 0b11)
0F	Auto wake-up actions completed
1	System voltage is above the POR threshold ($V_{SYSA} > V_{POR}$).
2	Chip overtemperature lockout ($T_J > T_{OTLO}$) OR SYSA undervoltage lockout ($V_{SYSA} < V_{SYSAUVLO} + V_{SYSAUVLO_HYS}$) OR SYSA overvoltage lockout ($V_{SYSA} > V_{SYSAOVLO}$)
3	Any resources force enabled OR Internal wake-up flags are set (see the Internal Wake-Up Flags (MAX77643) section)
4	Main bias enable time expires (t_{SBIAS_EN}) AND Conditions in Transition 2 are not met.
5A	FPS power-up sequence has not happened yet AND Resources are not forced off AND Internal wake-up flags are set (see the Internal Wake-Up Flags (MAX77643) section)
5B	FPS power-up sequence completed
6A	FPS power-up sequence completed AND Software cold reset (CNFG_GLBL0.SFT_CTRL[1:0] = 0b01) OR Software power-off (CNFG_GLBL0.SFT_CTRL[1:0] = 0b10) OR Software auto wake-up (CNFG_GLBL0.SFT_CTRL = 0b11) OR Watchdog timer expired OR Manual reset occurred (ERCFLAG.MRT = 1) OR CNFG_GLBL1.SBB_F_SHUTDOWN = 0b1 AND SBB fault occurs
6B	FPS power-down sequence finished
7	Last resource turned off

Internal Wake-Up Flags (MAX77643)

After transitioning to the shutdown state because of a reset, to allow the device to power up again, internal wake-up flags are set to remember the wake-up request. In [Figure 7](#) and [Table 6](#), these internal wake-up flags trigger transition 3. The internal wake-up flags are set when any of the following happen:

- nEN is debounced (see the [nEN Enable Input \(MAX77643\)](#) section)
 - For example, after a push-button is pressed or a slide-switch switched to HIGH.
- Software cold reset command sent (CNFG_GLBL0.SFT_CTRL[1:0] = 0b01)

Reset, Off, and Auto Wake-Up Sequences (MAX77643)

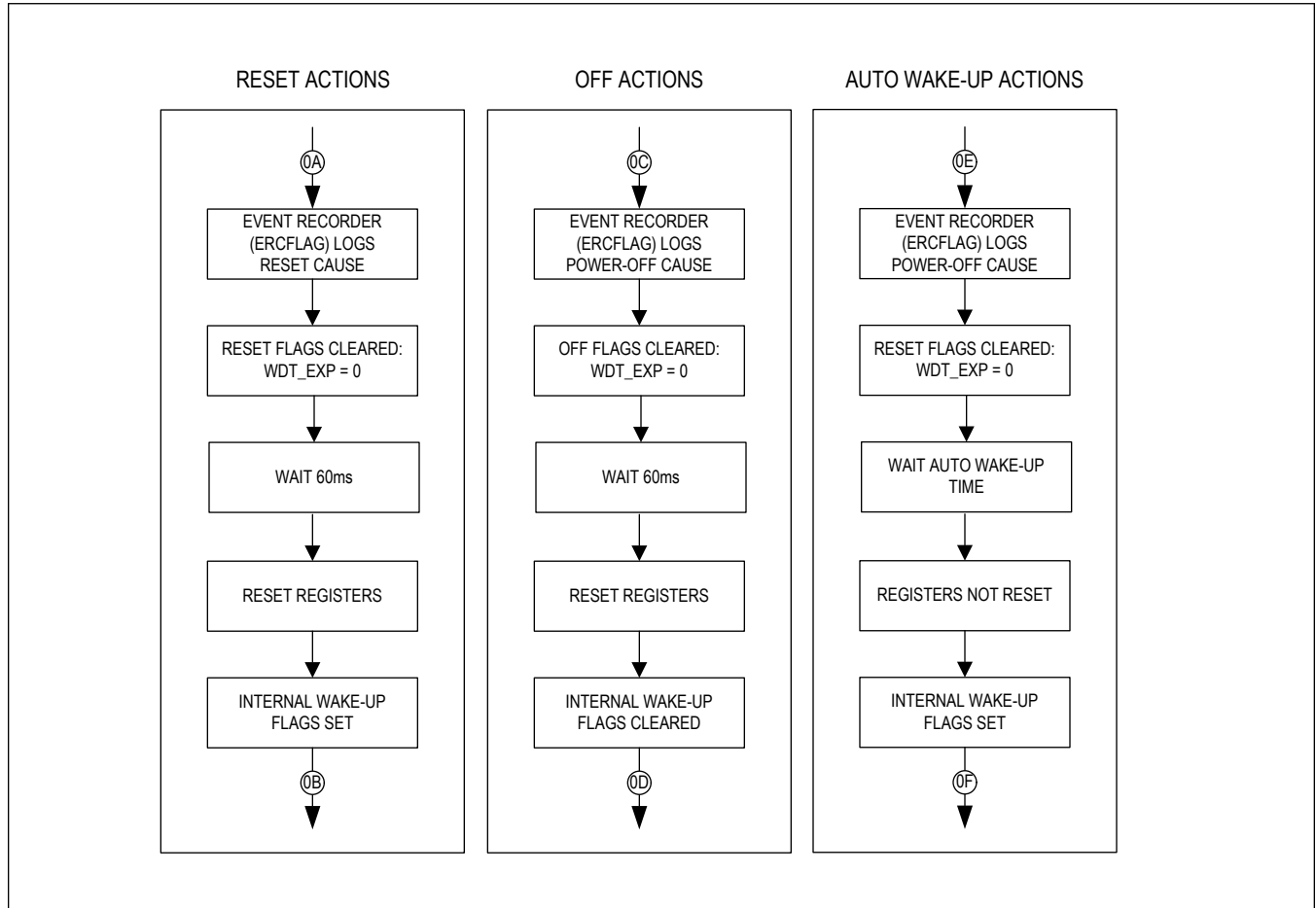

Figure 8. On/Off Controller Reset and Off-Action Sequences

Power-Up/Down Sequence (MAX77643)

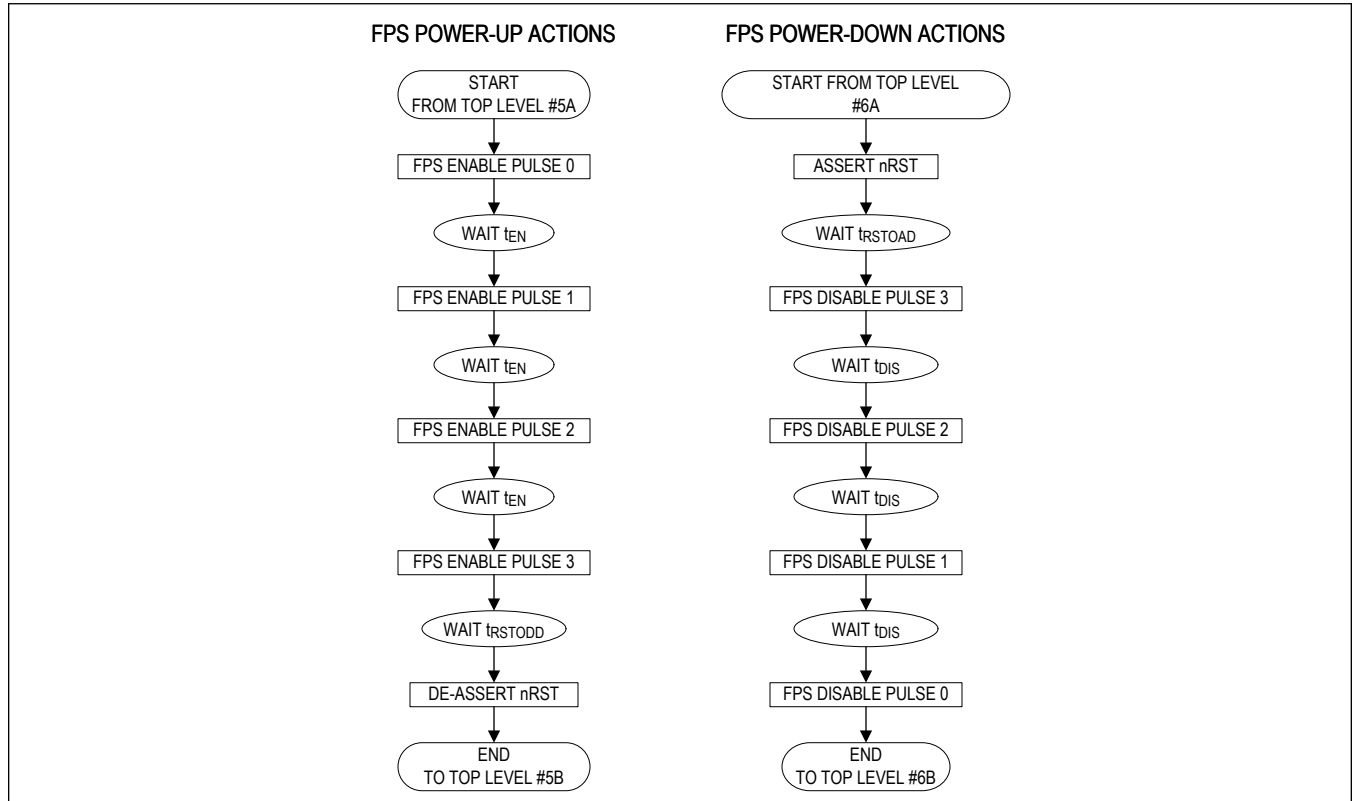

Figure 9. Power-Up/Down Sequence

Flexible Power Sequencer (FPS) (MAX77643)

The FPS allows resources to power up under hardware or software control. Additionally, each resource can power up independently or among a group of other regulators with adjustable power-up/down delays (sequencing). [Figure 10](#) shows four resources powering up under the control of the flexible power sequencer.

The flexible sequencing structure consists of one master sequencing timer and four slave resources (SBB0, SBB1, SBB2 and LDO0). When the FPS is enabled, a master timer generates four sequencing events for device power-up/down.

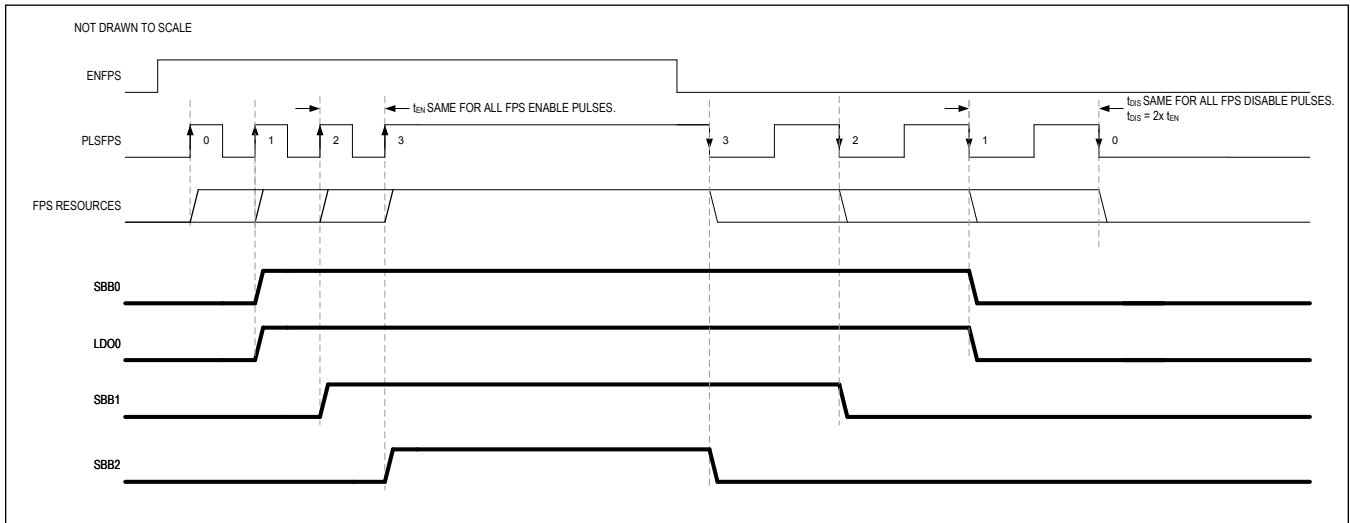

Figure 10. Flexible Power Sequencer Basic Timing Diagram

Startup Timing Diagram Due to nEN (MAX77643)

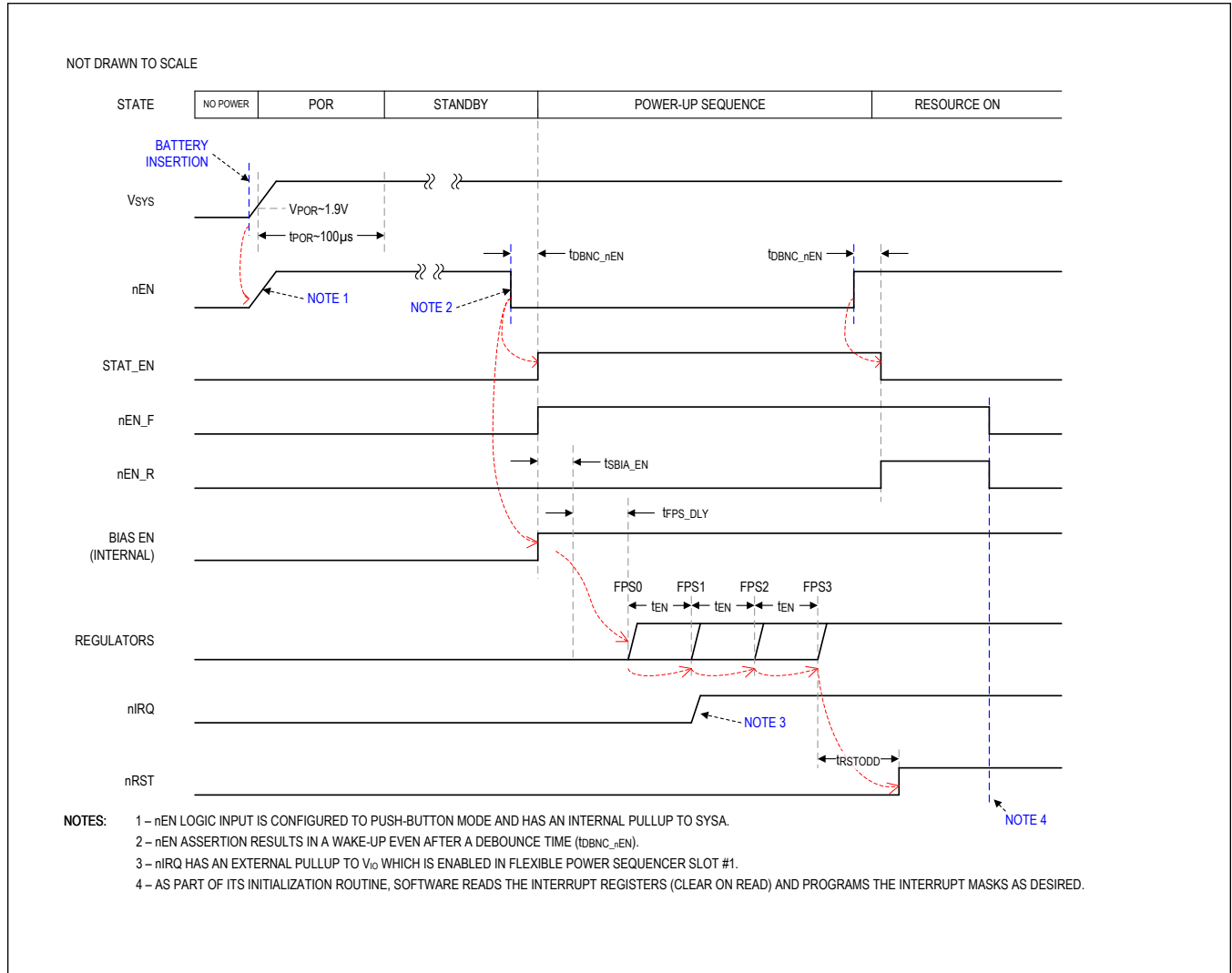

Figure 11. Startup Timing Diagram Due to nEN

Force Enabled/Disabled Channels (MAX77643)

Force enable SIMO and LDO output channels by setting CNFG_SBBx_B.EN_SBBx[2:0] (SIMO) or CNFG_LDOx_B.EN_LDOx[2:0] (LDO) = 0x6. Depending on the OTP, output channels may already be force enabled by default. Output channels configured this way are independent of the flexible power sequence and start up as soon as SYS > UVLO rising. The main bias also automatically turns on.

Likewise, output channels can be force disabled by setting EN_SBBx[2:0] or EN_LDOx[2:0] = 0x4.

Debounced Inputs (nEN, GPI) (MAX77643)

The nEN and GPIO (when operating as an input) have programmable debounce timers on both the rising and falling edges to reject undesired transitions. The input must be at a stable logic level for the entire debounce period for the output to change its logic state. [Figure 12](#) shows an example timing diagram for the nEN debounce.

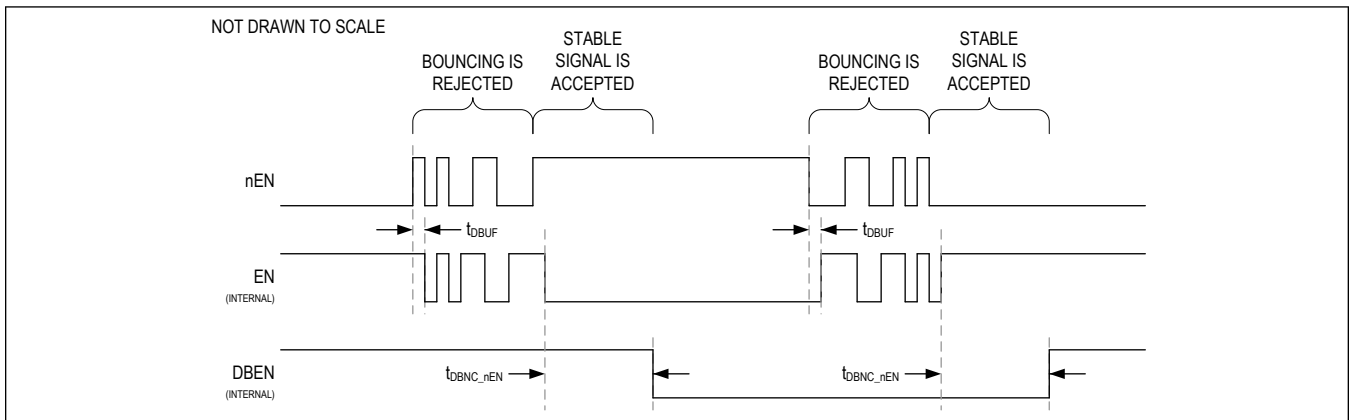

Figure 12. Debounced Inputs

Watchdog Timer (WDT) (MAX77643)

The IC features a watchdog timer function for operational safety. If this timer expires without being cleared, the on/off controller causes the IC to enter the shutdown state and resets configuration registers. See the [On/Off Controller](#) and [On/Off Controller Transition Table \(MAX77643\)](#) sections (transitions 0A and 0C) for more details.

Write `CNFG_WDT.WDT_EN = 1` through the I²C interface to enable the timer. The watchdog timer period (t_{WD}) is configurable from 16 seconds to 128 seconds in four steps with `CNFG_WDT.WDT_PER[1:0]`. The default timer period is 128 seconds. While the watchdog timer is enabled, the `CNFG_WDT.WDT_CLR` bit must be set through the I²C interface periodically (within t_{WD}) to reset the timer and prevent shutdown. See the *Register Map* and [Figure 13](#) for additional details.

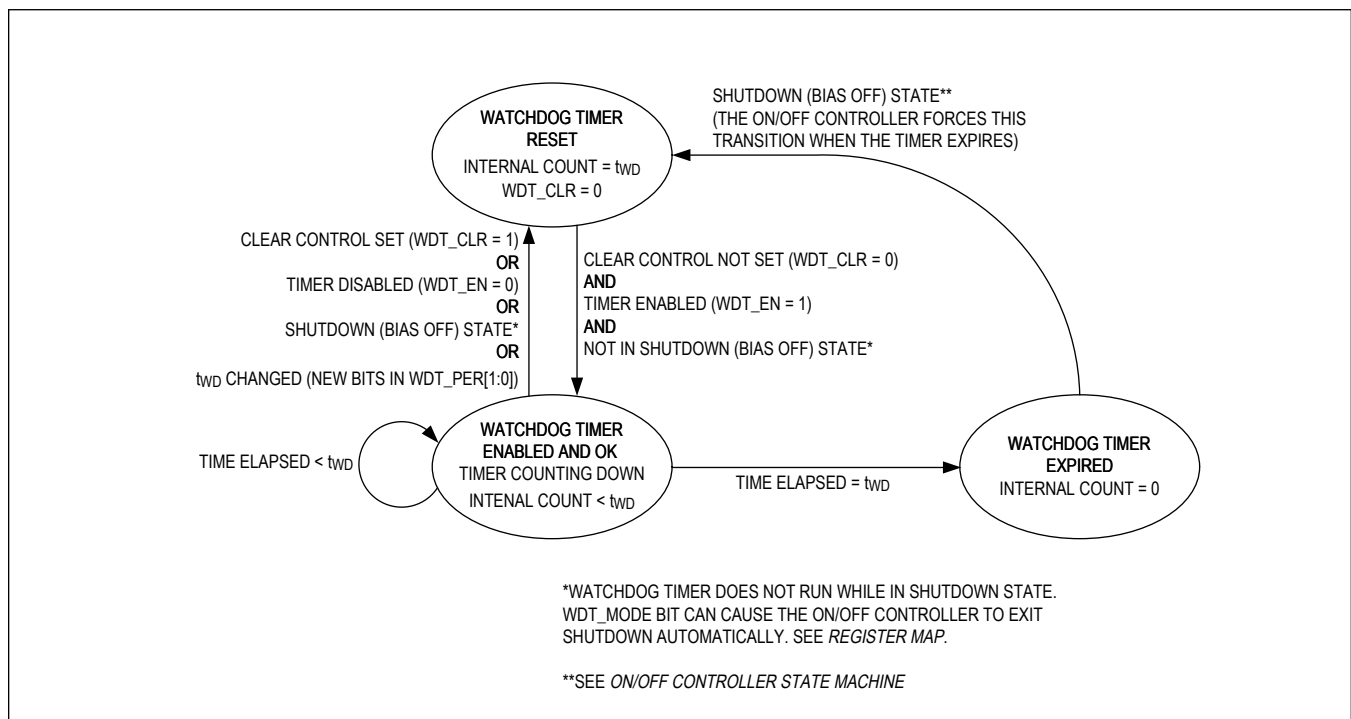

Figure 13. Watchdog Timer State Machine

The timer can be factory-programmed to be enabled by default, disabled by default, or locked from accidental disable. The `CNFG_WDT.WDT_LOCK` bit is read-only and must be configured at the factory. See [Table 7](#) for a full description.

Table 7. Watchdog Timer Factory-Programmed Safety Options

WDT_LOCK	WDT_EN	FUNCTION
0	0	Watchdog timer is disabled by default. Timer can be enabled or disabled by I ² C writes.
0	1	Watchdog timer is enabled by default. Timer can be enabled or disabled by I ² C writes.
1	0	Watchdog timer is disabled by default. Timer can be enabled by an I ² C write, but only a SYSRST can reset the <code>CNFG_WDT.WDT_EN</code> value back to 0. Timer can not be disabled by direct I ² C writes to <code>CNFG_WDT.WDT_EN</code> (write from 1 → 0 is ignored, write from 0 → 1 is accepted).
1	1	Watchdog timer is enabled by default. Nothing can disable the timer.

Detailed Description—SIMO Buck-Boost

The device has a micropower single-inductor, multiple-output (SIMO) buck-boost DC-to-DC converter designed for applications that emphasize low supply current and small solution size. A single inductor is used to regulate three separate outputs, saving board space while delivering better total system efficiency than equivalent power solutions using one buck and linear regulators.

The buck-boost configuration utilizes the entire battery voltage range due to its ability to create output voltages that are above, below, or equal to the input voltage. Peak inductor current for each output is programmable to optimize the balance between efficiency, output ripple, EMI, PCB design, and load capability.

To further boost efficiency when the output voltage is always lower than the input, individual channels of the SIMO buck-boost converter can be configured to be in buck-only or boost-only mode, reducing switching losses by toggling less switches compared to buck-boost mode. See the [SIMO Buck Mode \(MAX77643\)](#) and [SIMO Boost Mode \(MAX77643\)](#) sections for more details.

SIMO Features and Benefits

- Three Output Channels
- Ideal for Low-Power Designs
 - Delivers up to 500mA at 1.8V from a 3.7V Input
 - $\pm 2\%$ Accurate Output Voltage
- Small Solution Size
 - Multiple Outputs from a Single 1.5 μ H Inductor
 - Small 10 μ F (0402) Output Capacitors
- Flexible and Easy to Use
 - Single Mode of Operation
 - Glitchless Transitions Between Buck, Boost, and Buck-Boost Modes
 - Programmable Peak Inductor Current
 - Programmable On-Chip Active Discharge
 - Programmable Buck-Only and Boost-Only Mode (MAX77643)
 - Resistor Programmable Output Voltages (MAX77642)
- Long Battery Life
 - High Efficiency, > 91% at 1.8V Output
 - Better Total System Efficiency than Buck + LDOs
 - Low Quiescent Current, 1 μ A per Output
 - Low Input Operating Voltage, 2.7V (min)

SIMO Detailed Block Diagram

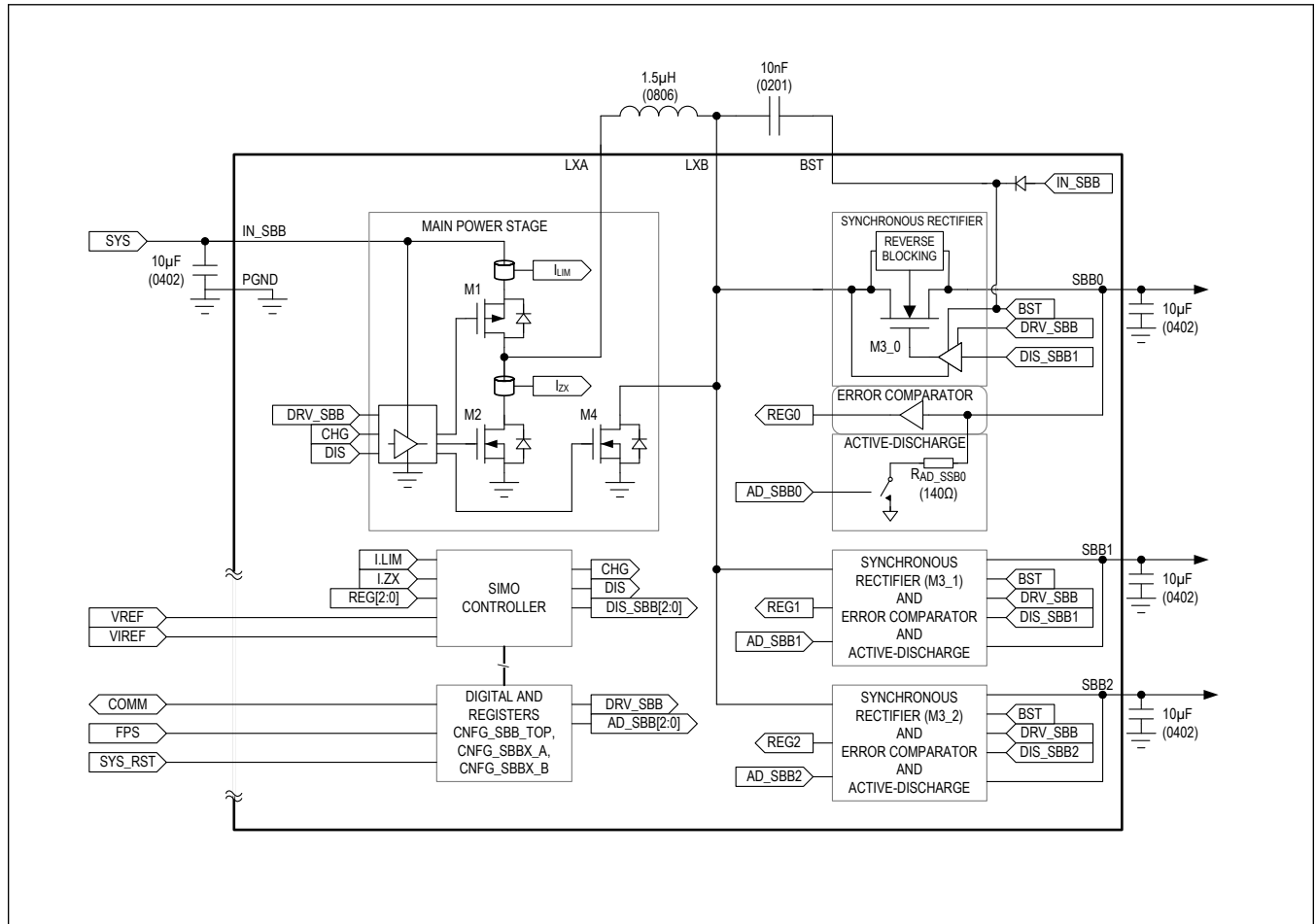

Figure 14. SIMO Detailed Block Diagram

SIMO Control Scheme

The SIMO buck-boost is designed to service multiple outputs simultaneously. A proprietary controller ensures that all outputs get serviced in a timely manner, even while multiple outputs are contending for the energy stored in the inductor. When no regulator needs service, the state machine rests in a low-power rest state.

When the controller determines that a regulator requires service, it charges the inductor ($M1 + M4$) until the peak current limit is reached ($I_{LIM} = \text{CNFG_SBBx_B.IP_SBB}[1:0]$). The inductor energy then discharges ($M2 + M3_x$) into the output until the current reaches zero (I_{ZX}). In the event that multiple output channels need servicing at the same time, the controller ensures that no output utilizes all of the switching cycles. Instead, cycles interleave between all the outputs that are demanding service, while outputs that do not need service are skipped.

Drive Strength (MAX77643)

The SIMO regulator's drive strength for its internal power MOSFETs is adjustable using the `CNFG_SBB_TOP.DRV_SBB[1:0]` bit field. The ideal value is determined experimentally for each application. For a PCB layout comparable to the MAX77642/MAX77643 evaluation kit, 0x1 is the best setting and represents a balance between efficiency and EMI. Faster settings result in higher efficiency but generally require stricter layout rules or shielding to avoid additional EMI. Slower settings limit EMI in non-ideal settings (e.g., contained layout, antennae adjacent to the device, etc.). Change the drive strength only once during system initialization.

SIMO Output Voltage Configuration

Each of the SIMO outputs are independently configurable. To set the output voltages at SBB0/1/2 for the MAX77642, connect the appropriate resistors from RSET_SBB0/1/2 to GND as shown in [Table 8](#) and [Table 9](#). The RSET_SBB0/1/2 resistors should have 1% or better tolerance. To set the output voltages at SBB0/1/2 for the MAX77643, use the I²C interface to load the configuration registers CNFG_SBBx_A.TV_SBBx[7:0]. This 8-bit configuration is a linear transfer function that starts at 0.5V and ends at 5.5V with 25mV increments, and sets the output voltage as: $SBBx = 0.5V + 25mV \times TV_SBBx[7:0]$ (decimal).

Table 8. SBB0 Output Voltage Settings

RSET_SBB0 (kΩ)	OUTPUT VOLTAGE - SBB0 (V)
0.001	0.50
4.99	0.60
6.00	0.70
7.15	0.80
8.45	0.90
10.0	1.00
11.8	1.05
14.0	1.10
16.9	1.20
20.0	1.30
23.7	1.40
28.0	1.60
34.0	1.75
40.2	1.80
47.5	1.85
56.2	2.00
66.5	2.20
80.6	2.40
95.76	2.80
113.0	3.00
133.0	3.20
162.0	3.25
191.0	3.30
226.0	3.35
267.0	3.40
324.0	3.80
383.0	4.00
452.0	4.20
536.0	4.40
634.0	4.60
768.0	5.00
909.0	5.20

Table 9. SBB1/2 Output Voltage Settings

RSET_SBB1/2 (kΩ)	OUTPUT VOLTAGE - SBB1/2 (V)
0.001	0.50
4.99	0.60
6.00	0.70
7.15	0.80
8.45	0.90
10.0	1.00
11.8	1.10
14.0	1.20
16.9	1.30
20.0	1.40
23.7	1.60
28.0	1.80
34.0	2.00
40.2	2.20
47.5	2.40
56.2	2.60
66.5	2.80
80.6	3.00
95.76	3.20
113.0	3.30
133.0	3.40
162.0	3.60
191.0	3.80
226.0	4.00
267.0	4.20
324.0	4.40
383.0	4.60
452.0	4.80
536.0	5.00
634.0	5.20
768.0	5.40
909.0	5.50

Peak Current Configuration

The peak inductor current limit corresponding to each SIMO output are independently configurable. To set the inductor peak current for the MAX77642, connect the appropriate resistors from RSET_IPK to GND as shown in [Table 10](#). The RSET_IPK resistors should have a 1% or better tolerance. To set the inductor peak current for the MAX77643, use the I²C interface to load the configuration registers CNFG_SBBx_B.IP_SBBx[5:4].

Table 10. Inductor Peak Current Setting

RSET_IPK (kΩ)	SBB_PK2 (A)	SBB_PK1 (A)	SBB_PK0 (A)
Short	0.5	0.5	0.5
4.99	0.5	0.5	1.0
6.00	0.5	1.0	0.5
7.15	1.0	0.5	0.5
8.45	1.0	1.0	0.5
10.0	1.0	0.5	1.0
11.8	0.5	1.0	1.0
14.0	1.0	1.0	1.0

SIMO Soft-Start

The soft-start feature of the SIMO limits inrush current during startup. The soft-start feature is achieved by limiting the slew rate of the output voltage during startup (dV/dt_{SS}).

More output capacitance results in higher input current surges during startup. The following equations and example describe the input current surge phenomenon during startup.

In buck-boost mode, the current into the output capacitor (I_{CSBB}) during soft-start is:

$$I_{CSBB} = C_{SBB} \times \frac{dV}{dt_{SS}} \quad \left(\text{Equation 1} \right)$$

where:

- C_{SBB} is the capacitance on the output of the regulator
- dV/dt_{SS} is the voltage change rate of the output

The input current (I_{IN}) during soft-start is:

$$I_{IN} = \frac{(I_{CSBB} + I_{LOAD}) \frac{V_{SBBx}}{V_{IN}}}{\xi} \quad \left(\text{Equation 2} \right)$$

where:

- I_{CSBB} is calculated using Equation 1
- I_{LOAD} is current consumed from the external load
- V_{SBBx} is the output voltage
- V_{IN} is the input voltage
- ξ is the efficiency of the regulator

For example, given the following conditions, the peak input current (I_{IN}) during soft-start is ~71mA:

Given:

- V_{IN} is 3.5V
- V_{SBB2} is 3.3V
- $C_{SBB2} = 10\mu\text{F}$
- $dV/dt_{SS} = 5\text{mV}/\mu\text{s}$
- $R_{LOAD2} = 330\Omega$ ($I_{LOAD2} = 3.3\text{V}/330\Omega = 10\text{mA}$)
- ξ is 80%

Calculation:

- $I_{CSBB} = 10\mu\text{F} \times 5\text{mV}/\mu\text{s}$ (from Equation 1)
- $I_{CSBB} = 50\text{mA}$
- $I_{IN} = \frac{(50\text{mA} + 10\text{mA}) \frac{3.3\text{V}}{3.5\text{V}}}{0.85}$ (from Equation 1)
- $I_{IN} \sim 71\text{mA}$

SIMO Registers (MAX77643)

Each SIMO buck-boost channel has a dedicated register to program its target output voltage (CNFG_SBBx_A.TV_SBBx[7:0]) and its peak current limit (CNFG_SBBx_B.IP_SBBx[1:0]). Additional controls are available for enabling/disabling the active-discharge resistors (CNFG_SBBx_B.ADE_SBBx), buck-only, boost-only, buck-boost only, and automatic mode (CNFG_SBBx_B.OP_MODE) as well as enabling/disabling the SIMO buck-boost channels (CNFG_SBBx_B.EN_SBBx[2:0]). For a full description of bits, registers, default values, and reset conditions, see the *Register Map*.

SIMO Active Discharge Resistance

Each SIMO buck-boost channel has an active-discharge resistor (R_{AD_SBBx}) that is automatically enabled/disabled based on a CNFG_SBBx_B.ADE_SBBx bit and the status of the SIMO regulator. The active discharge feature may be enabled (CNFG_SBBx_B.ADE_SBBx = 1) or disabled (CNFG_SBBx_B.ADE_SBBx = 0) independently for each SIMO channel. Enabling the active discharge feature helps ensure a complete and timely power down of all system peripherals. If the active-discharge resistor is enabled by default, then the active-discharge resistor is on whenever V_{SYSA} is below $V_{SYSAUVLO}$ and above V_{POR} .

These resistors discharge the output when CNFG_SBBx_B.ADE_SBBx = 1, and their respective SIMO channel is off. If the regulator is forced on through CNFG_SBBx_B.EN_SBBx[2:0] = 0b110 or 0b111, then the resistors do not discharge the output even if the regulator is disabled by the main-bias.

Note that when V_{SYSA} is less than 1.0V, the NMOS transistors that control the active-discharge resistors lose their gate drive and become open.

SIMO Buck Mode (MAX77643)

If the input voltage at IN_SBB never falls below the output voltage of one or more SIMO converter channels, individual channels can be configured to be in buck mode with the CNFG_SBBx_B.OP_MODE bit. In buck mode, when an output needs service, switch M3_x remains closed and M4 remains open (see [Figure 14](#)). Only M1 and M2 are toggled as in a traditional buck converter. Efficiency is boosted due to three major factors:

- Reduced switching loss: Buck mode toggles only two switches versus the four in buck-boost mode. Therefore, there are less switching events during which power is consumed.
- Lower inductor core losses: Inductor current changes from 0A to peak current. The larger the change in current the inductor experiences, the more energy is lost in the inductor core in the form of heat. In buck mode, the peak current can be reduced since less inductor current is needed to support a load. Less inductor current is needed because of direct energy transfer. Direct energy transfer occurs while the inductor is charged, when the input (IN_SBB) is connected directly to the output (SBBx) through the inductor. Therefore, the input not only provides energy to charge the inductor, energy is also supplied to the output capacitor and load devices. Therefore, less current is needed to charge the inductor, which is used to charge the output capacitor in the next switching state.
- Less frequent charging cycles: In buck-boost mode, the output capacitor is charged only while the inductor is being discharged. Again because of direct energy transfer, the output capacitor is charged during both the inductor charge and discharge times. In addition, with the same peak current limit, the inductor charge time is longer with buck mode. Therefore, the output capacitor can support the output voltage longer before needing to be recharged.

Maintain a minimum headroom of 0.7V between IN_SBB and SBBx in buck mode because inductor charge time ($dt = L \times I_{P_SBBx} / (V_{IN_SBB} - V_{SBBx})$) increases as the difference between the IN_SBB and SBBx voltages shrinks. As the inductor current takes longer to reach its peak, the output voltage might take too long to reach its target voltage, and the MAX77643 might trigger a fault flag.

SIMO Boost Mode (MAX77643)

If the input voltage at IN_SBB never rises above the output voltage of one or more SIMO converter channels, individual channels can be configured to be in boost mode with the CNFG_SBBx_B.OP_MODE bit. In boost mode, when an output needs service, switch M1 remains closed and M2 remains open (see [Figure 14](#)). Only M3x and M4 are toggled as in a traditional boost converter. Efficiency is boosted due to three major factors:

- Reduced switching loss: Boost mode toggles only two switches versus the four in buck-boost mode. Therefore, there are less switching events during which power is consumed.
- Lower inductor core losses: Inductor current changes from 0A to peak current. The larger the change in current the inductor experiences, the more energy is lost in the inductor core in the form of heat. In boost mode, the peak current can be reduced since less inductor current is needed to support a load. Less inductor current is needed because of direct energy transfer. Direct energy transfer occurs while the inductor is discharged, when the input (IN_SBB) is connected directly to the output (SBBx) through the inductor. Therefore, the input not only provides energy to charge the inductor, energy is also supplied to the output capacitor and load devices. Therefore, less current is needed to charge the inductor, which is used to charge the output capacitor in the next switching state.
- Less frequent charging cycles: The inductor discharge time is longer with boost mode. Therefore, the output capacitor can support the output voltage longer before needing to be recharged.

Applications Information

SIMO Available Output Current

The available output current on a given SIMO channel is a function of the input voltage, output voltage, the peak current limit setting, and the output current of the other SIMO channels. Maxim offers a calculator found in the design resources tab of the MAX77642/MAX77643's webpage that outlines the available capacity for specific conditions. [Table 11](#) is an extraction from the calculator.

Table 11. SIMO Available Output Current for Common Applications

PARAMETERS	EXAMPLE 1	EXAMPLE 2	EXAMPLE 3	EXAMPLE 4	EXAMPLE 5
V _{IN_MIN}	2.7V	2.7V	3.2V	3.4V	3.6V
R _{L_DCR}	0.1Ω	0.1Ω	0.1Ω	0.12Ω	0.12Ω
SBB0	1.0V at 100mA	1.0V at 80mA	1.2V at 50mA	1.2V at 20mA	1.2V at 20mA
SBB1	1.2V at 75mA	1.2V at 50mA	2.05V at 100mA	2.05V at 80mA	2.05V at 80mA
SBB2	1.8V at 50mA	1.8V at 40mA	3.3V at 30mA	3.3V at 10mA	2.05V at 5mA
Operating Mode	Buck-Boost	Buck	Buck-Boost	Buck-Boost	Buck
I _{P_SBB0}	1A	1A	1A	0.5A	1A
I _{P_SBB1}	1A	1A	0.75A	0.5A	1A
I _{P_SBB2}	1A	1A	1A	0.5A	0.5A
Utilized Capacity	73%	77%	79%	73%	79%

* $ESR_{C_{IN}} = ESR_{C_{OUT}} = 5m\Omega$, $L = 1.5\mu H$

Inductor Selection

Choose an inductance from 1.0μH to 2.2μH; 1.5μH inductors work best for most designs. Larger inductances transfer more energy to the output for each cycle and typically result in larger output voltage ripple and better efficiency. See the [Output Capacitor Selection](#) section for more information on how to size your output capacitor in order to control ripple.

Choose the inductor saturation current to be greater than or equal to the maximum peak current limit setting that is used for all of the SIMO buck-boost channels (I_{P_SBBx}). For example, if SBB0 is set for 0.5A, SBB1 is set for 0.75A, and SBB2 is set for 1.0A, then choose the saturation current to be greater than or equal to 1.0A.

Choose the RMS current rating of the inductor (typically the current at which the temperature rises appreciably) based on the expected load currents for the system. For systems where the expected load currents are not well known, be conservative and choose the RMS current to be greater than or equal to half the higher maximum peak current limit setting [$I_{RMS} \geq \text{MAX}(I_{P_SBB0}, I_{P_SBB1}, I_{P_SBB2}) / 2$]. This is a conservative choice because the SIMO buck-boost regulator implements a discontinuous conduction mode (DCM) control scheme, which returns the inductor current to zero each cycle.

Consider the DC-resistance (DCR), AC-resistance (ACR), and solution size of the inductor. Typically, smaller sized inductors have larger DC-resistance and larger AC-resistance that reduces efficiency and the available output current. Note that many inductor manufacturers have inductor families which contain different versions of core material in order to balance trade-offs between DCR, ACR (i.e., core losses), and component cost. For this SIMO regulator, inductors with the lowest ACR in the 1.0MHz to 2.0MHz region tend to provide the best efficiency.

Input Capacitor Selection

Choose the input bypass capacitance (C_{IN_SBB}) to be 10 μ F. Larger values of C_{IN_SBB} improve the decoupling for the SIMO regulator.

The C_{IN_SBB} reduces the current peaks drawn from the battery or input power source during SIMO regulator operation and reduces switching noise in the system. The ESR/ESL of the input capacitor should be very low (i.e., $ESR \leq 5m\Omega$ and $ESL \leq 500pH$) for frequencies up to 2MHz. Ceramic capacitors with X5R or X7R dielectric are highly recommended due to their small size, low ESR, and small temperature coefficients.

To fully utilize the available input voltage range of the SIMO (5.5V, max), use a capacitor with a voltage rating of 6.3V at minimum.

Boost Capacitor Selection

Choose the boost capacitance (C_{BST}) to be 10nF. Smaller values of C_{BST} (< 1nF) result in insufficient gate drive for M3. Larger values of C_{BST} (> 10nF) have the potential to degrade the startup performance. Ceramic capacitors with 0201 or 0402 case size are recommended.

Output Capacitor Selection

Choose each output bypass capacitance (C_{SBBx}) based on the target output voltage ripple (ΔV_{SBBx}). Typical values are 22 μ F. Larger values of C_{SBBx} improve the output voltage ripple but increase the input surge currents during soft-start and output voltage changes. The output voltage ripple is a function of the inductance (L), the output voltage (V_{SBBx}), and the peak current limit setting (I_{P_SBBx}). See Equation 3 to estimate required, effective capacitance.

$$C_{SBBx} = \frac{I_{P_SBBx}^2 \times L}{2 \times V_{SBBx} \times \Delta V_{SBBx}} \text{(Equation 3)}$$

Maxim also offers a calculator to aid in the selection of the output capacitance found in the design resources tab of the MAX77642/MAX77643 product page. Note that most designs concern themselves with having enough capacitance on the output but there is also a maximum capacitance limitation that is calculated within the SIMO calculator; take care not to exceed the maximum capacitance.

The C_{SBBx} is required to keep the output voltage ripple small. The impedance of the output capacitor (ESR, ESL) should be very low (i.e., $ESR \leq 5m\Omega$ and $ESL \leq 500pH$) for frequencies up to 2MHz. Ceramic capacitors with X5R or X7R dielectric are highly recommended due to their small size, low ESR, and small temperature coefficients.

A capacitor's effective capacitance decreases with increased DC bias voltage. This effect is more pronounced as capacitor case sizes decrease. Due to this characteristic, it is possible for an 0603 case size capacitor to perform well, while an 0402 case size capacitor of the same value performs poorly. The SIMO regulator is stable with low output capacitance (1 μ F) but the output voltage ripple would be large; consider the effective output capacitance value after initial tolerance, bias voltage, aging, and temperature derating.

SIMO Switching Frequency

The SIMO buck-boost regulator uses a pulse frequency modulation (PFM) control scheme. The switching frequency for each output is a function of the operating mode, input voltage, output voltage, load current, and inductance. Output capacitance is a minor factor in SIMO switching frequency. Maxim offers a SIMO calculator found in the design resources tab of the MAX77642/MAX77643 product page to estimate expected switching frequency.

[Table 12](#) lists how different factors increase or decrease switching frequency.

Table 12. Switching Frequency Control

FACTOR	INCREASING FREQUENCY	DECREASING FREQUENCY
--------	----------------------	----------------------

Table 12. Switching Frequency Control (continued)

Inductor Current Peak Limit	Lower peak limit	Higher peak limit
Operating Mode	Buck-boost mode	Buck mode or boost mode
Inductor	Decrease inductance	Increase inductance
Output Capacitor	Decrease capacitance	Increase capacitance
Input Voltage	Higher voltage	Lower voltage
Output Voltage	Higher voltage	Lower voltage
Load Current	Higher current	Lower current

Unused Outputs

Do not leave unused outputs unconnected. If an output left unconnected is accidentally enabled, the charged inductor experiences an open circuit, and the output voltage soars above the absolute maximum rating, damaging the device. If an output is not used, do one of the following:

1. Disable the output (CNFG_SBBx_B.EN_SBBx[2:0] = 0x4 or 0x5) and connect the output to ground. If an unused output is default enabled or can be accidentally enabled, do one of the other recommendations instead.
2. Bypass the unused output with a 1µF capacitor to ground.
3. Connect the unused output to IN_SBB or a different output channel if the unused output is programmed to a lower voltage. Since the output voltage is higher than the unused output, the regulator does not service the unused output even if it is unintentionally enabled.
 - Note that some OTP options have the active-discharge resistors enabled by default. Connecting an unused output to IN_SBB is **not recommended** if the active discharge is enabled by default. If connecting the unused output to a different channel, disable the active-discharge resistor (CNFG_SBBx_B.ADE_SBBx = 0) of the unused channel.

PCB Layout Guide**Capacitors**

Place decoupling capacitors as close as possible to the IC such that connections from capacitor pads to pin and from capacitor pads to ground pins are short. Keeping the connections short lowers parasitic inductance and resistance, improving performance and shrinking the physical size of hot loops.

If connections to the capacitors are through vias, use multiple vias to minimize parasitics. Also, connect loads to the capacitor pads rather than the device pins.

Most critical are the capacitors for the switching regulator: input capacitor at IN_SBB and output capacitors at SBBx.

Input Capacitor at IN_SBB

Minimize the parasitic inductance from PGND to input capacitor to IN_SBB to reduce ringing on the LXA voltage.

Output Capacitors at SBBx

The output capacitors experience large changes in current as the regulator charges (buck mode) and discharges (both modes) the inductor. In buck mode, the capacitor current ramps up at the same rate as mentioned in the [Input Capacitor at IN_SBB](#) section. In buck-boost mode, the capacitor current ramps up very quickly. In both modes, the capacitor current ramps down at a rate of $\frac{dI_{C_SBBx}}{dt} = \frac{V_{SBBx}}{L}$ from inductor peak current. Since the ramp down can occur in less than 1µs, and the current increases rapidly for buck-boost mode, minimize parasitic inductance from SBBx to output capacitor to PGND.

Inductor

Keep the inductor close to the IC to reduce trace resistance; however, prioritize any regulator input/output capacitors over the inductor. Use the appropriate trace width from LXA to inductor to LXB to support the peak inductor current. Likewise, if there are vias in the path, use an appropriate amount of vias to support the peak current.

Ground Connections

As the switching regulator charges and discharges the inductor, current flows from PGND to the input capacitor ground, from output capacitor ground to PGND, or from output capacitor ground to input capacitor ground. Therefore, use a wide, continuous copper plane to connect PGND to the capacitor grounds.

When connecting the GND and PGND pins together, ensure noise from the power ground does not enter the analog ground (where GND is connected). For example, assuming the ground pins are connected through a solid ground plane on an internal layer, one via connecting GND to the internal ground plane may be sufficient to protect GND from most of the noise in the power-ground plane. Likewise, if there are other higher current or noisy circuitry near this device, avoid connecting the GND pin directly to their grounds.

For more guidelines on proper grounding, visit: <https://www.maximintegrated.com/en/design/partners-and-technology/design-technology/ground-layout-board-designers.html>.

Example PCB Layout

Figure 15 shows an example layout of the top layer.

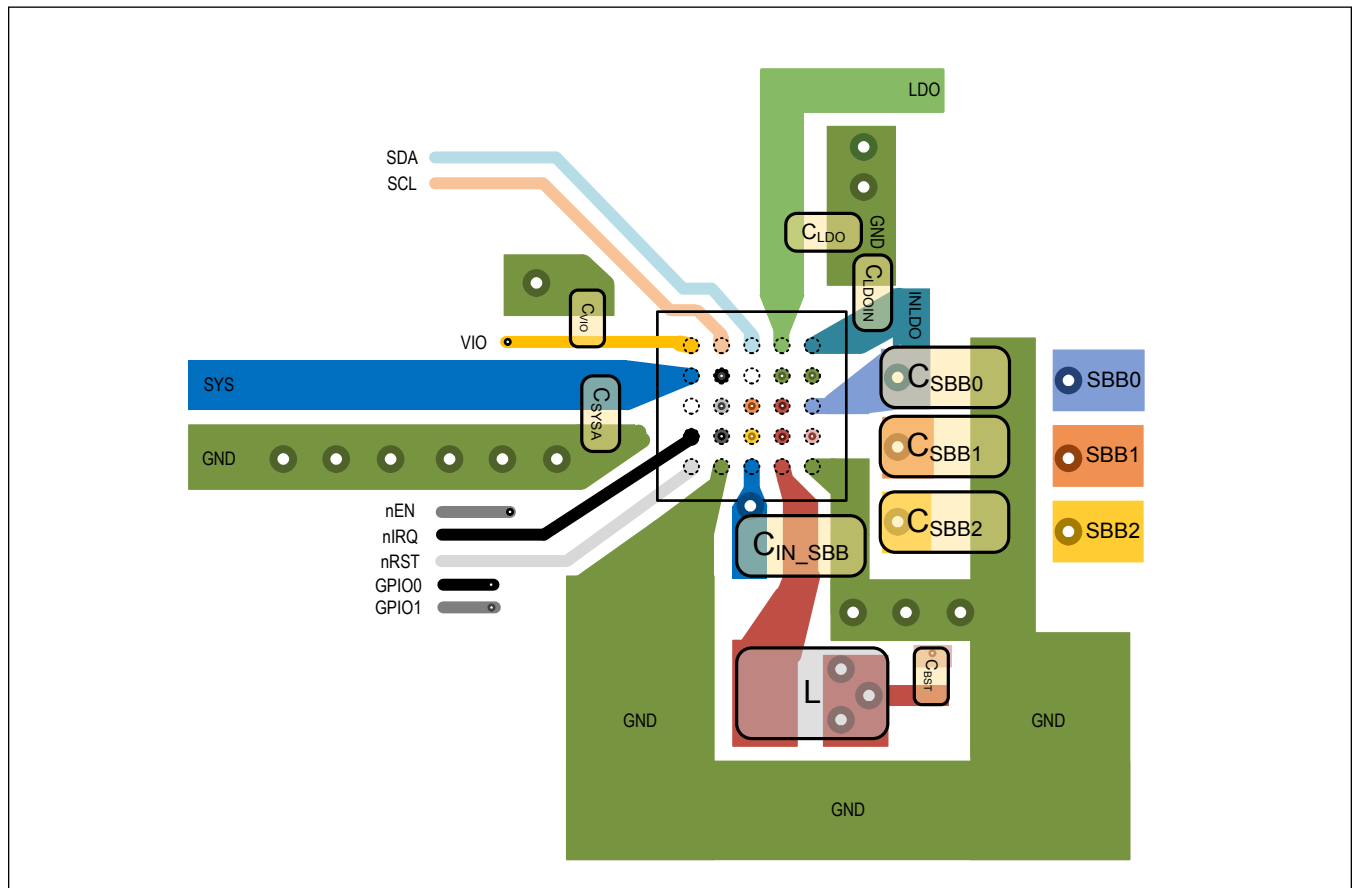

Figure 15. PCB Top-Layer and Component Placement Example

Detailed Description—Low Dropout Linear Regulator (LDO)/Load Switch (LSW)

The device includes an on-chip low-dropout linear regulator (LDO0) that can also be configured as load switches. The LDO is optimized to have low-quiescent current. The input voltage range (V_{IN_LDO}) allows it to be powered directly from the main energy source such as a Li-Poly battery or from an intermediate regulator. The linear regulator delivers up to 150mA.

Features and Benefits

- 1x 150mA LDO
- LDO Input Voltage Range: 1.71V to 5.5V
- LSW Input Voltage Range: 1.20V to 5.5V
- Resistor Adjustable Output Voltage (MAX77642)
- I²C Adjustable Output Voltage (MAX77643)
- 100mV Maximum Dropout Voltage at ECT Conditions
- Programmable On-Chip Active Discharge

LDO/LSW Simplified Block Diagram

The LDO/LSW block has one input (IN_LDO) and one output (LDO) and several ports that exchange information with the rest of the device (V_{REF} , EN_LDO , ADE_LDO). The V_{REF} comes from the main bias circuits. The $CNFG_LDO0_B.EN_LDO$ and $CNFG_LDO0_B.ADE_LDO$ are register bits for controlling the enable and active-discharge feature, respectively. See the *Register Map* for more information.

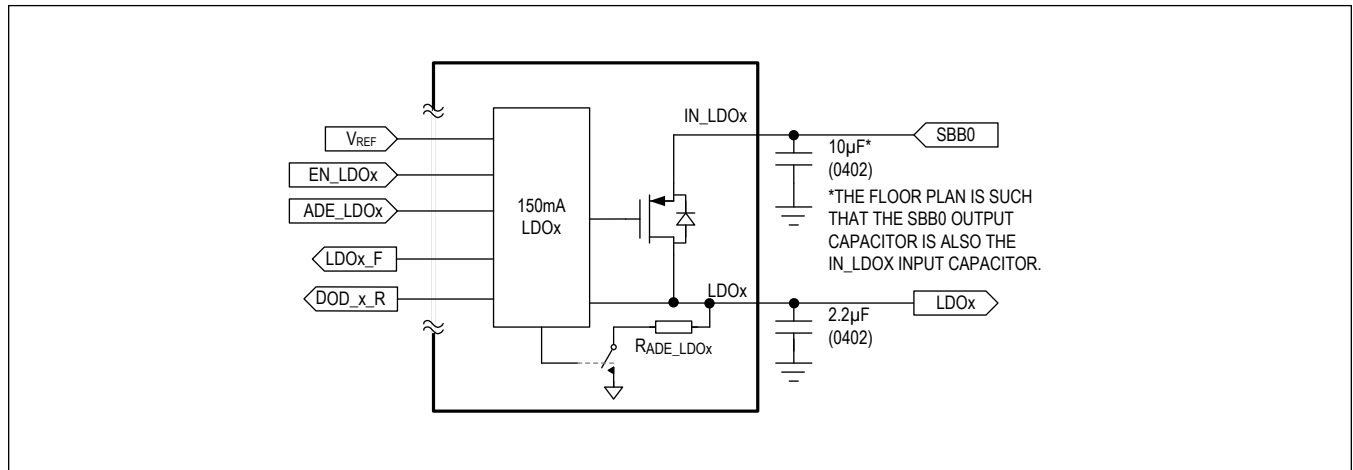

Figure 16. LDO Simplified Block Diagram

LDO Output Voltage Configuration

To set the output voltages for the on-chip LDO for the MAX77642, connect the appropriate resistor from $RSET_LDO$ to GND as shown in [Table 13](#). $RSET_LDO$ resistor should have 1% or better tolerance. To set the output voltages for the on-chip LDO for the MAX77643, use the I²C interface to load the configuration register $TV_LDO[7:0]$. $TV_LDO[7]$ is used to enable ($TV_LDO[7] = 1$) or disabled ($TV_LDO[7] = 0$) a 1.325mV offset to the LDO's output voltage. The bits $TV_LDO[6:0]$ are used to set the output voltage as:

$$LDO = 0.5V + TV_LDO[7] + (25mV \times TV_LDO[6:0] \text{ (decimal)})$$

Table 13. LDO Output Voltage Setting

RSET_LDO (k Ω)	LDO OUTPUT VOLTAGE (V)
Short	0.50
4.99	0.60
6.00	0.70
7.15	0.80
8.45	0.90
10.0	0.95
11.8	1.00
14.0	1.05
16.9	1.10
20.0	1.15
23.7	1.20
28.0	1.25
34.0	1.30
40.2	1.40
47.5	1.50
56.2	1.60
66.5	1.70
80.6	1.80
95.76	1.90
113.0	2.00
133.0	2.10
162.0	2.20
191.0	2.40
226.0	2.50
267.0	2.60
324.0	2.80
383.0	3.00
452.0	3.20
536.0	3.40
634.0	3.60
768.0	3.80
909.0	4.00

LDO/LSW Active-Discharge Resistor

The LDO/LSW block has an active-discharge resistor (R_{AD_LDO}) that is enabled if $CNFG_LDO0_B.ADE_LDO = 1$ and LDO is disabled. Enabling the active discharge feature helps ensure a complete and timely power down of the resource. During power up, if $V_{SYSA} > V_{POR}$ and $CNFG_LDO0_B.ADE_LDO = 1$, the active-discharge resistor is enabled.

LDO/LSW Soft-Start

The soft-start feature limits inrush current during startup, and is achieved by limiting the slew rate of the output voltage during startup (dV_{OUT_LDO}/dt_{SS}).

More output capacitance results in higher input current surges during startup. The following equation and example describe the input current surge phenomenon during startup.

The input current (I_{IN_LDO}) during soft-start is calculated as:

$$I_{IN_LDOx} = C_{LDOx} \frac{dV_{OUT_LDOx}}{dt_{SS}} + I_{OUT_LDOx}$$

where:

- C_{LDO} is the capacitance on the output of the regulator
- dV_{OUT_LDO}/dt_{SS} is the voltage change rate of the output

For example, given the following conditions, the input current (I_{IN_LDO}) during soft-start is 13.08mA:

Given:

- $C_{LDO} = 2.2\mu\text{F}$
- $dV_{OUT_LDO}/dt_{SS} = 2.2\text{mV}/\mu\text{s}$
- LDO programmed to 1.85V
- $R_{LDO} = 185\Omega$ ($I_{OUT_LDO} = 1.85\text{V}/185\Omega = 10\text{mA}$)

Calculation:

- $I_{IN} = 2.2\mu\text{F} \times 2.2\text{mV}/\mu\text{s} + 10\text{mA}$
- $I_{IN} = 14.84\text{mA}$

Load Switch Configuration

The LDO0 can be configured as load switches with the `CNFG_LDO0_B.LDO_MD` bit. As shown in [Figure 17](#), the transition from LDO to LSW mode is controlled by a defined slew rate until dropout is detected. Once dropout is detected, the load switch is fully closed and the dropout interrupt flag (`INT_GLBL.DOD_R`) is set.

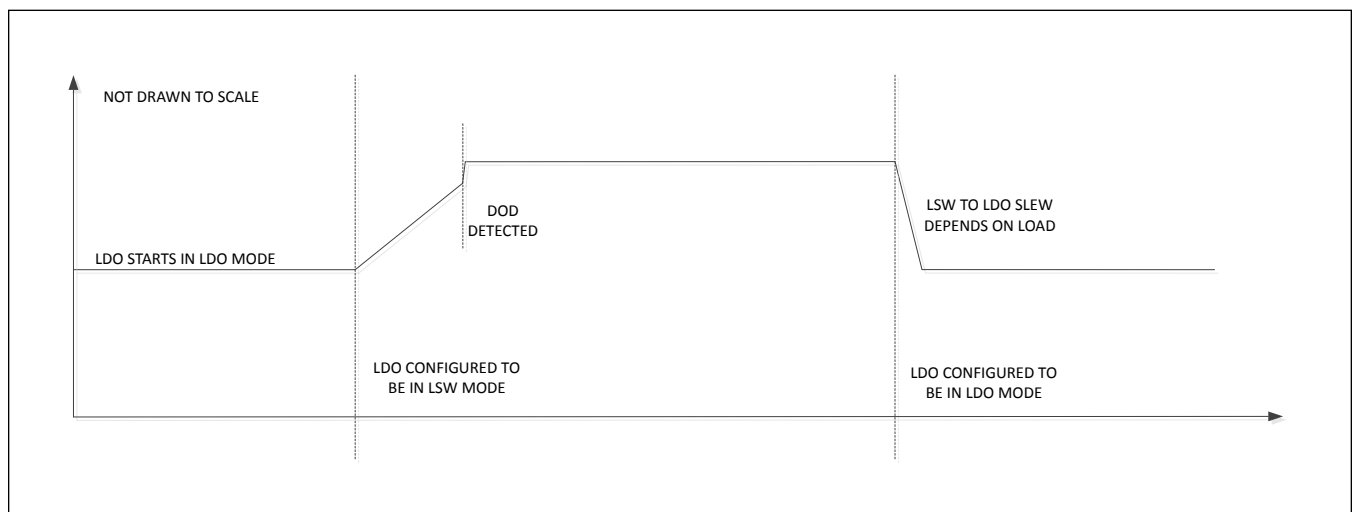

Figure 17. LDO to LSW Transition Waveform

Applications Information

Input Capacitor Selection

Make sure the input bypass capacitance (C_{IN_LDO}) is at least $2.2\mu\text{F}$. Larger values of C_{IN_LDO} improve the decoupling for LDO. The floor plan of the device is such that SBB0 is adjacent to IN_LDO and if the SIMO channel 0 output powers the input of LDO, then its output capacitor (C_{SBB0}) can also serve as C_{IN_LDO} such that only one capacitor is required.

The C_{IN_LDO} reduces the current peaks drawn from the battery or input power source during operation. The impedance of the input capacitor (ESR, ESL) should be very low (i.e., $\text{ESR} \leq 50\text{m}\Omega$ and $\text{ESL} \leq 5\text{nH}$) for frequencies up to 0.5MHz . Ceramic capacitors with X5R or X7R dielectric are highly recommended due to their small size, low ESR, and small temperature coefficients.

Output Capacitor Selection

For both LDO and LSW modes, choose the output bypass capacitance (C_{LDO}) to be $1\mu\text{F}$.

In LDO mode, larger values of C_{LDO} improve output PSRR but increase input surge currents during soft-start and output voltage changes. The effective output capacitance should not exceed $2.8\mu\text{F}$ to maintain stability.

While in LDO mode, C_{LDO} is required to keep stability. The series inductance of the output capacitor and its series resistance should be low (i.e., $\text{ESR} \leq 10\text{m}\Omega$ and $\text{ESL} \leq 1\text{nH}$) for frequencies up to 0.5MHz . Ceramic capacitors with X5R or X7R dielectric are highly recommended due to their small size, low ESR, and small temperature coefficients.

A capacitor's effective capacitance decreases with increased DC bias voltage. This effect is more pronounced with smaller capacitor case sizes. Due to this characteristic, 0603 case size capacitors tend to perform well while 0402 case size capacitors of the same value perform poorly.

Detailed Description—I²C Serial Communication

General Description

The IC features a revision 3.0 I²C-compatible, 2-wire serial interface consisting of a bidirectional serial data line (SDA) and a serial clock line (SCL). This device acts as a slave-only device, relying on the master to generate a clock signal. SCL clock rates from 0Hz to 3.4MHz are supported.

The I²C is an open-drain bus and therefore SDA and SCL require pullups. Optional resistors (24Ω) in series with SDA and SCL protect the device inputs from high-voltage spikes on the bus lines. Series resistors also minimize crosstalk and undershoot on bus signals.

[Figure 18](#) shows the functional diagram for the I²C-based communications controller. For additional information on I²C, refer to the *I²C Bus Specification and User Manual* which is available for free through the internet.

Features

- I²C Revision 3.0 Compatible Serial Communications Channel
- 0Hz to 100kHz (Standard Mode)
- 0Hz to 400kHz (Fast Mode)
- 0Hz to 1MHz (Fast-Mode Plus)
- 0Hz to 3.4MHz (High-Speed Mode)
- Does not utilize I²C Clock Stretching

I²C Simplified Block Diagram

There are three pins (aside from GND) for the I²C-compatible interface. The V_{IO} determines the logic level, SCL is the clock line, and SDA is the data line. Note that the interface does **not** have the ability to drive the SCL line.

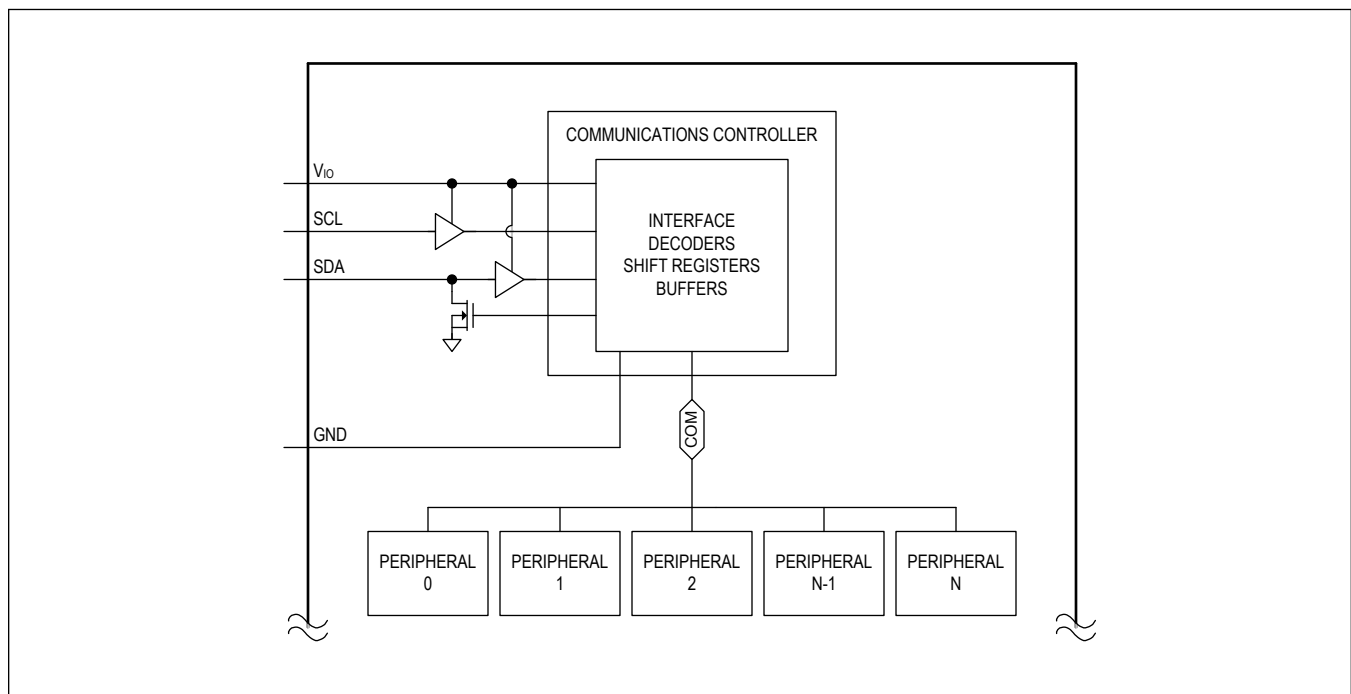

Figure 18. I²C Simplified Block Diagram

I²C System Configuration

The I²C-compatible interface is a multimaster bus. The maximum number of devices that can attach to the bus is only limited by bus capacitance.

A device on the I²C bus that sends data to the bus is called a transmitter. A device that receives data from the bus is called a receiver. The device that initiates a data transfer and generates the SCL clock signals to control the data transfer is a master. Any device that is being addressed by the master is considered a slave. The I²C-compatible interface operates as a slave on the I²C bus with transmit and receive capabilities.

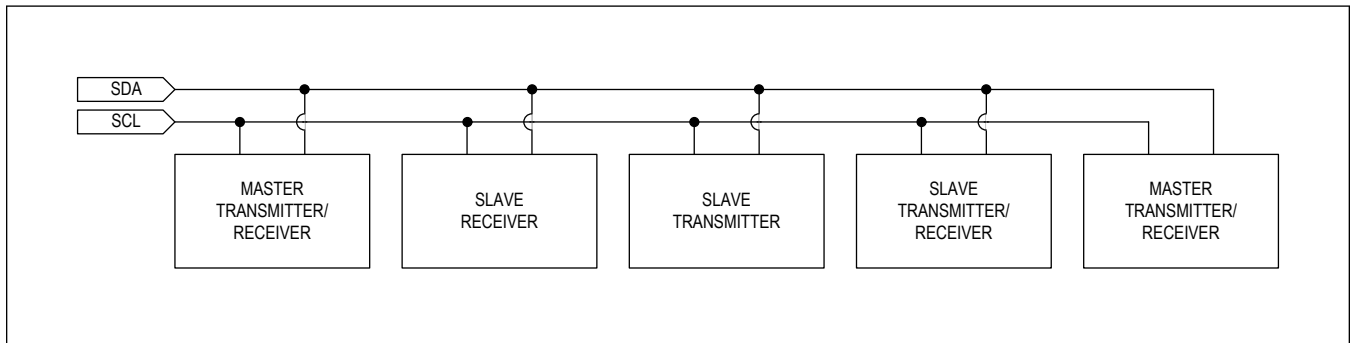

Figure 19. I²C System Configuration

I²C Interface Power

The I²C interface derives its power from V_{IO} . Typically a power input such as V_{IO} would require a local 0.1 μ F ceramic bypass capacitor to ground. However, in highly integrated power distribution systems, a dedicated capacitor might not be necessary. If the impedance between V_{IO} and the next closest capacitor ($\geq 0.1\mu$ F) is less than 100m Ω in series with 10nH, then a local capacitor is not needed. Otherwise, bypass V_{IO} to GND with a 0.1 μ F ceramic capacitor.

The V_{IO} accepts voltages from 1.7V to 3.6V (V_{IO}). Cycling V_{IO} does not reset the I²C registers. When V_{IO} is less than V_{IOUVLO} and V_{SYSA} is less than $V_{SYSAUVLO}$, SDA and SCL are high impedance.

I²C Data Transfer

One data bit is transferred during each SCL clock cycle. The data on SDA must remain stable during the high period of the SCL clock pulse. Changes in SDA while SCL is high are control signals. See the [I²C Start and Stop Conditions](#) section. Each transmit sequence is framed by a START (S) condition and a STOP (P) condition. Each data packet is 9 bits long: 8 bits of data followed by the acknowledge bit. Data is transferred with the MSB first.

I²C Start and Stop Conditions

When the serial interface is inactive, SDA and SCL idle high. A master device initiates communication by issuing a START condition. A START condition is a high-to-low transition on SDA with SCL high. A STOP condition is a low-to-high transition on SDA, while SCL is high. See [Figure 20](#).

A START condition from the master signals the beginning of a transmission to the device. The master terminates transmission by issuing a not-acknowledge followed by a STOP condition (see the [I²C Acknowledge Bit](#) section for information on not-acknowledge). The STOP condition frees the bus. To issue a series of commands to the slave, the master can issue repeated start (Sr) commands instead of a STOP command to maintain control of the bus. In general a repeated start command is functionally equivalent to a regular start command.

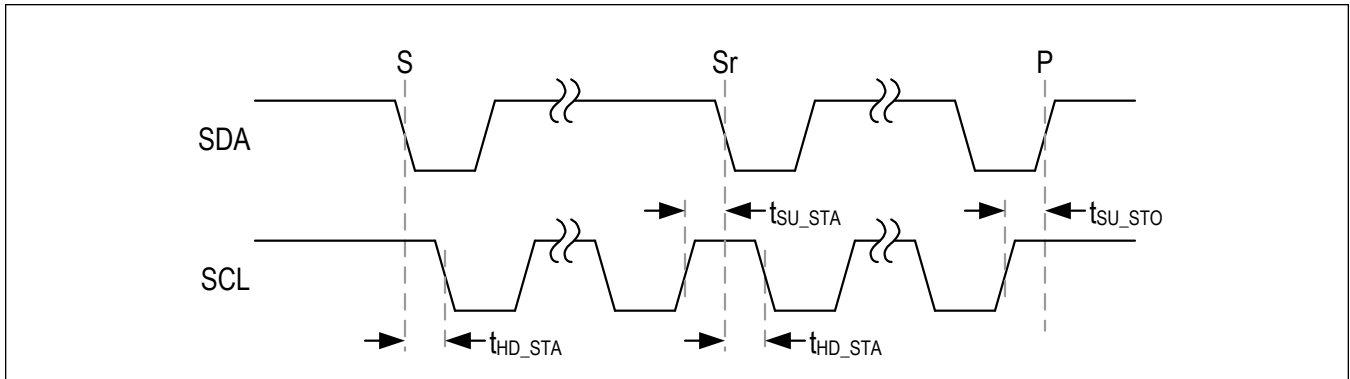

Figure 20. I²C Start and Stop Conditions

I²C Acknowledge Bit

Both the I²C bus master and slave devices generate acknowledge bits when receiving data. The acknowledge bit is the last bit of each 9-bit data packet. To generate an acknowledge (A), the receiving device must pull SDA low before the rising edge of the acknowledge-related clock pulse (ninth pulse) and keep it low during the high period of the clock pulse. See Figure 21. To generate a not-acknowledge (nA), the receiving device allows SDA to be pulled high before the rising edge of the acknowledge-related clock pulse and leaves it high during the high period of the clock pulse.

Monitoring the acknowledge bits allows for detection of unsuccessful data transfers. An unsuccessful data transfer occurs if a receiving device is busy or if a system fault has occurred. In the event of an unsuccessful data transfer, the bus master should reattempt communication at a later time.

This device issues an ACK for all register addresses in the possible address space even if the particular register does not exist.

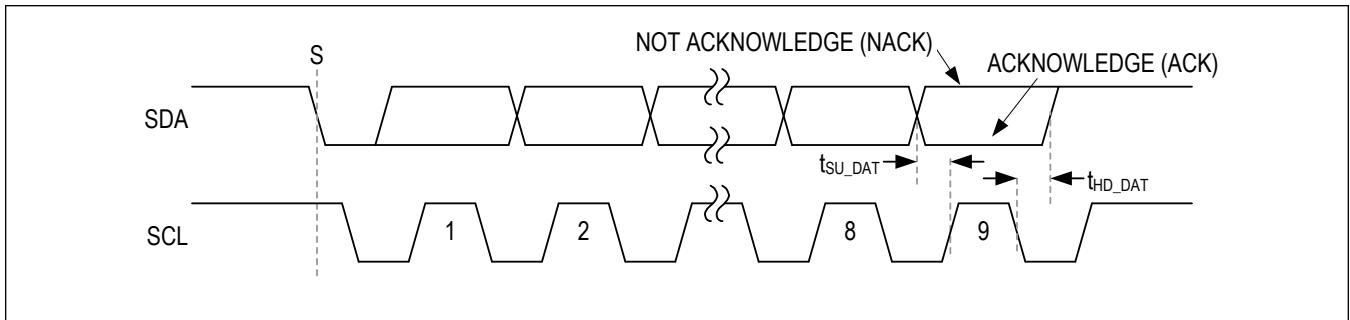

Figure 21. Acknowledge Bit

I²C Slave Address

The I²C controller implements 7-bit slave addressing. An I²C bus master initiates communication with the slave by issuing a START condition followed by the slave address. See [Figure 22](#). The OTP address is factory-programmable for one of two options. See [Table 14](#). All slave addresses not mentioned in [Table 14](#) are not acknowledged.

Table 14. I²C Slave Address Options

ADDRESS	7-BIT SLAVE ADDRESS	8-BIT WRITE ADDRESS	8-BIT READ ADDRESS
Main Address (ADDR = 0)*	0x40, 0b 100 0000	0x80, 0b 1000 0000	0x81, 0b 1000 0001
Main Address (ADDR = 1)*	0x48, 0b 100 1000	0x90, 0b 1001 0000	0x91, 0b 1001 0001
Main Address (ADDR = 2)*	0x44, 0b 100 0100	0x88, 0b 1000 1000	0x89, 0b 1000 1001
Main Address (ADDR = 3)*	0x4C, 0b 100 1100	0x98, 0b 1001 1000	0x99, 0b 1001 1001
Test Mode**	0x49, 0b 100 1001	0x92, 0b 1001 0010	0x93, 0b 1001 0011

*Perform all reads and writes on the main address. The ADDR is a factory one-time programmable (OTP) option, allowing for address changes in the event of a bus conflict.

**When test mode is unlocked, the additional address is acknowledged. Test mode details are confidential. If possible, leave the test mode address unallocated to allow for the rare event that debugging needs to be performed in cooperation with Maxim.

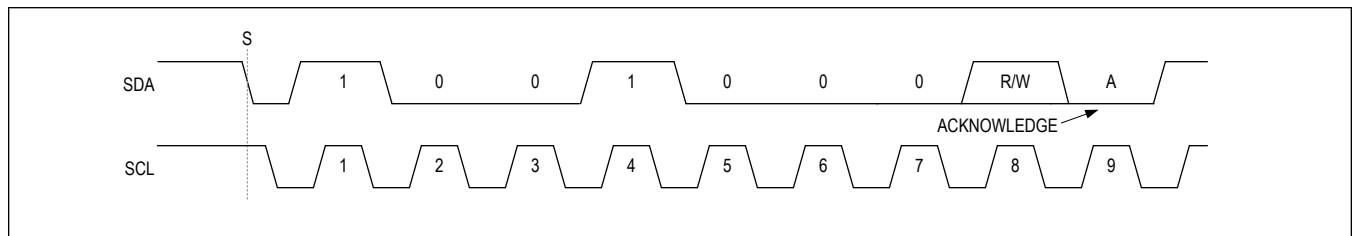

Figure 22. Slave Address Example

I²C Clock Stretching

In general, the clock signal generation for the I²C bus is the responsibility of the master device. The I²C specification allows slow slave devices to alter the clock signal by holding down the clock line. The process in which a slave device holds down the clock line is typically called clock stretching. The IC does not use any form of clock stretching to hold down the clock line.

I²C General Call Address

This device does not implement the I²C specifications general call address and does not acknowledge the general call address (0b0000_0000).

I²C Device ID

This device does not support the I²C Device ID feature.

I²C Communication Speed

This device is compatible with all four communication speed ranges as defined by the revision 3.0 I²C specification:

- 0Hz to 100kHz (Standard Mode)
- 0Hz to 400kHz (Fast Mode)
- 0Hz to 1MHz (Fast-Mode Plus)
- 0Hz to 3.4MHz (High-Speed Mode)

Operating in standard mode, fast mode, and fast-mode plus does not require any special protocols. The main consideration when changing bus speed through this range is the combination of the bus capacitance and pullup resistors. Larger values of bus capacitance and pullup resistance increase the time constant ($C \times R$), slowing bus operation. Therefore, when increasing bus speeds, the pullup resistance must be decreased to maintain a reasonable time constant. Refer to the *Pullup Resistor Sizing* section of the I²C bus specification and user manual (available for free on the internet) for detailed guidance on the pullup resistor selection. In general for bus capacitances of 200pF, a 100kHz bus needs 5.6k Ω pullup resistors, a 400kHz bus needs about 1.5k Ω pullup resistors, and a 1MHz bus needs 680 Ω pullup resistors. Remember that, while the open-drain bus is low, the pullup resistor is dissipating power, and lower value pullup resistors dissipate more power (V^2/R).

Operating in high-speed mode requires some special considerations. For a full list of considerations, refer to the publicly available I²C bus specification and user manual. Major considerations with respect to this part are:

- The I²C bus master uses current source pullups to shorten the signal rise.
- The I²C slave must use a different set of input filters on its SDA and SCL lines to accommodate for the higher bus.
- The communication protocols need to utilize the high-speed master code.

At power-up and after each stop condition, the bus input filters are set for standard mode, fast mode, and fast-mode plus (i.e., 0Hz to 1MHz). To switch the input filters for high-speed mode, use the high-speed master code protocols that are described in the [I²C Communication Protocols](#) section.

I²C Communication Protocols

Both writing to and reading from registers are supported as described in the following subsections.

Writing to a Single Register

[Figure 23](#) shows the protocol for the I²C master device to write one byte of data to this device. This protocol is the same as the SMBus specification's write byte protocol.

The write byte protocol is as follows:

1. The master sends a start command (S).
2. The master sends the 7-bit slave address followed by a write bit ($R/W = 0$).
3. The addressed slave asserts an acknowledge (A) by pulling SDA low.
4. The master sends an 8-bit register pointer.
5. The slave acknowledges the register pointer.
6. The master sends a data byte.
7. The slave updates with the new data.
8. The slave asserts an acknowledge or not acknowledge for the data byte. The next rising edge on SDA loads the data byte into its target register and the data becomes active.
9. The master sends a stop condition (P) or a repeated start condition (Sr). Issuing a P ensures that the bus input filters are set for 1MHz or slower operation. Issuing an Sr leaves the bus input filters in their current state.

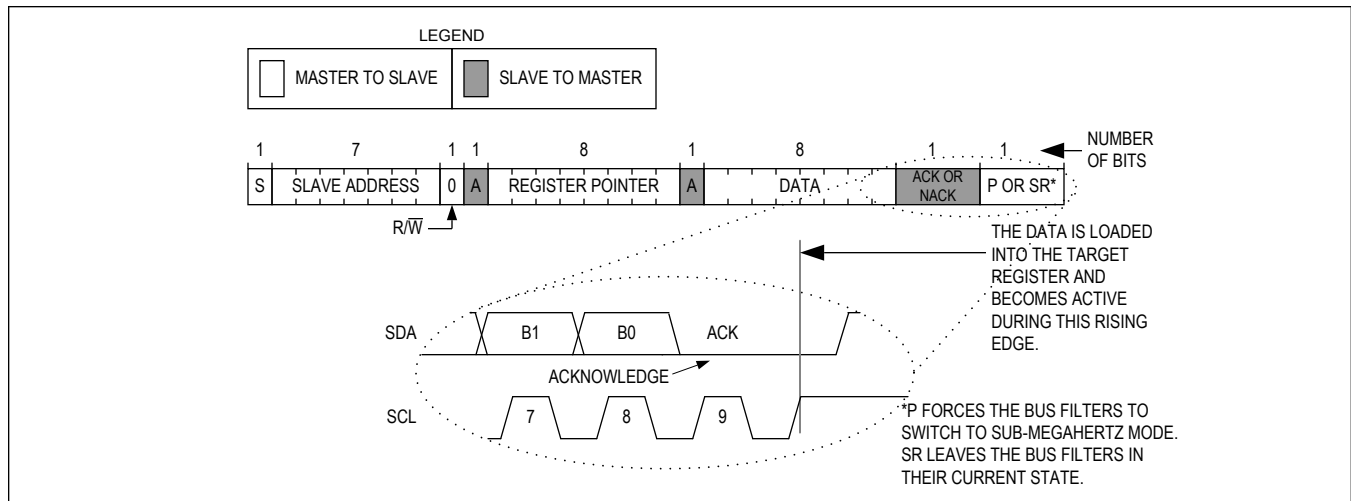

Figure 23. Writing to a Single Register with the Write Byte Protocol

Writing Multiple Bytes to Sequential Registers

Figure 24 shows the protocol for writing to sequential registers. This protocol is similar to the write byte protocol in the [Writing to a Single Register](#) section, except the master continues to write after it receives the first byte of data. When the master is done writing, it issues a stop or repeated start.

The write to sequential registers protocol is as follows:

1. The master sends a start command (S).
2. The master sends the 7-bit slave address followed by a write bit (R/W = 0).
3. The addressed slave asserts an acknowledge (A) by pulling SDA low.
4. The master sends an 8-bit register pointer.
5. The slave acknowledges the register pointer.
6. The master sends a data byte.
7. The slave acknowledges the data byte. The next rising edge on SDA loads the data byte into its target register and the data becomes active.
8. Steps 6 to 7 are repeated as many times as the master requires.
9. During the last acknowledge related clock pulse, the master can issue an acknowledge or a not acknowledge.
10. The master sends a stop condition (P) or a repeated start condition (Sr). Issuing a P ensures that the bus input filters are set for 1MHz or slower operation. Issuing an Sr leaves the bus input filters in their current state.

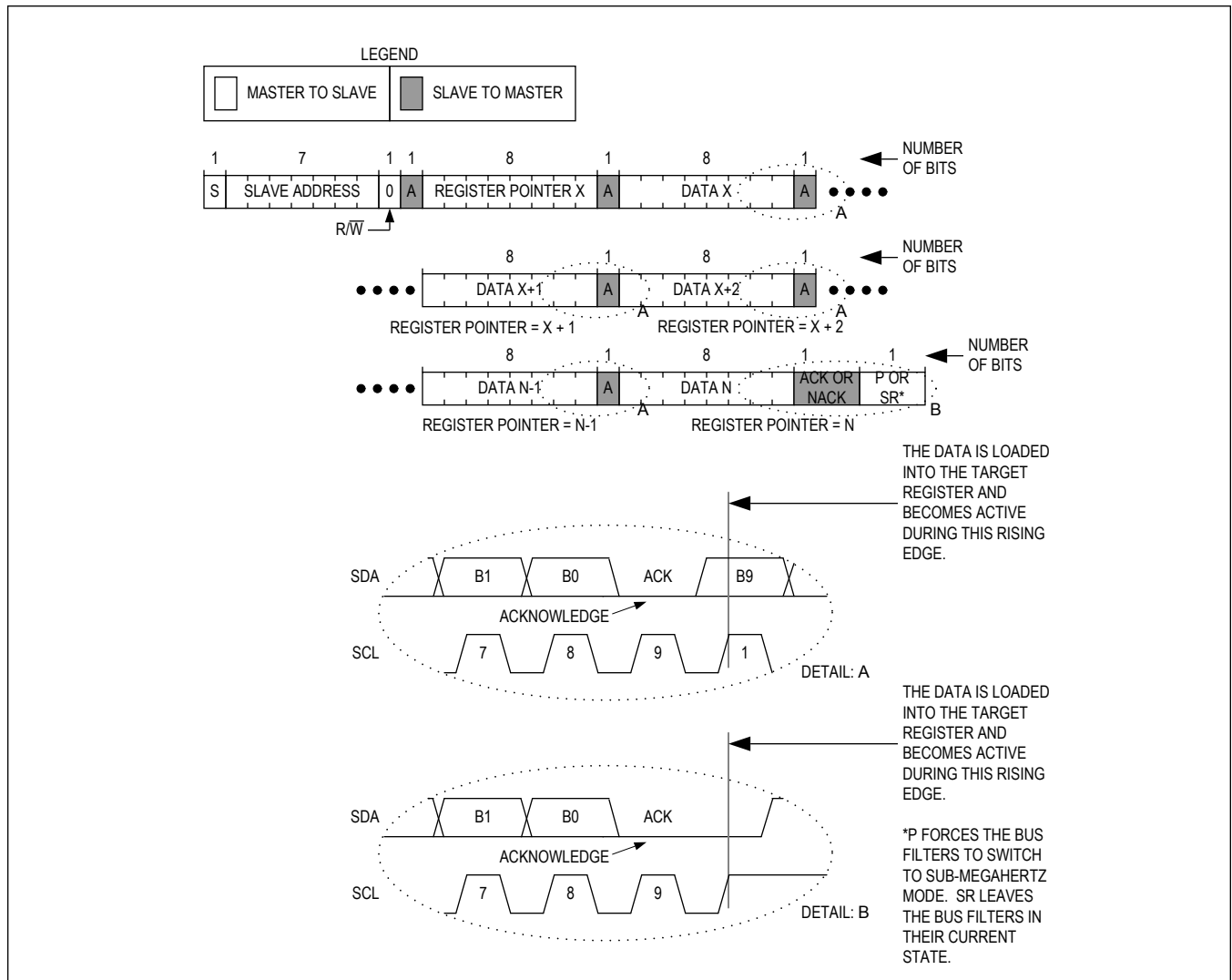

Figure 24. Writing to Sequential Registers X to N

Reading from a Single Register

Figure 25 shows the protocol for the I²C master device to read one byte of data. This protocol is the same as the SMBus specification’s read byte protocol.

The read byte protocol is as follows:

1. The master sends a start command (S).
2. The master sends the 7-bit slave address followed by a write bit (R/W = 0).
3. The addressed slave asserts an acknowledge (A) by pulling SDA low.
4. The master sends an 8-bit register pointer.
5. The slave acknowledges the register pointer.
6. The master sends a repeated start command (Sr).
7. The master sends the 7-bit slave address followed by a read bit (R/W = 1).
8. The addressed slave asserts an acknowledge by pulling SDA low.
9. The addressed slave places 8-bits of data on the bus from the location specified by the register pointer.
10. The master issues a not acknowledge (nA).
11. The master sends a stop condition (P) or a repeated start condition (Sr). Issuing a P ensures that the bus input filters are set for 1MHz or slower operation. Issuing an Sr leaves the bus input filters in their current state.

Note that when this device receives a stop, the register pointer is not modified. Therefore, if the master re-reads the same register, it can immediately send another read command, omitting the command to send a register pointer.

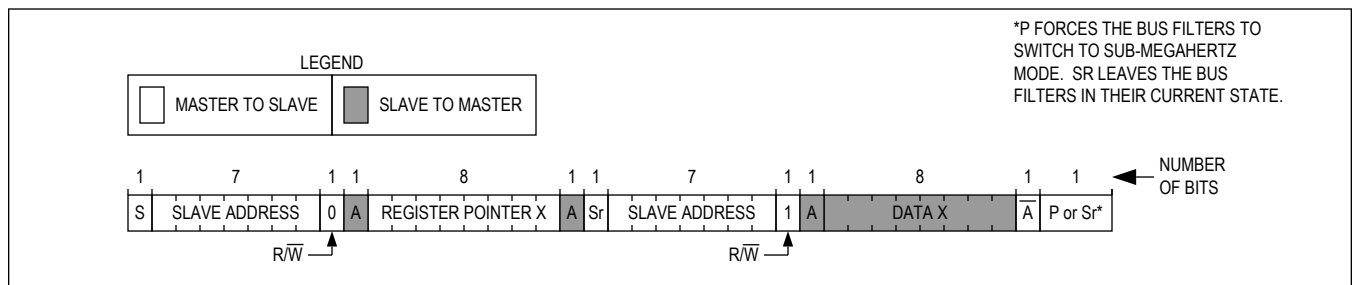

Figure 25. Reading from a Single Register with the Read Byte Protocol

Reading from Sequential Registers

Figure 26 shows the protocol for reading from sequential registers. This protocol is similar to the read byte protocol except the master issues an acknowledge to signal the slave that it wants more data. When the master has all the data it requires, it issues a not acknowledge (nA) and a stop (P) to end the transmission. The continuous read from sequential registers protocol is as follows:

1. The master sends a start command (S).
2. The master sends the 7-bit slave address followed by a write bit (R/W = 0).
3. The addressed slave asserts an acknowledge (A) by pulling SDA low.
4. The master sends an 8-bit register pointer.
5. The slave acknowledges the register pointer.
6. The master sends a repeated start command (Sr).
7. The master sends the 7-bit slave address followed by a read bit (R/W = 1).
8. The addressed slave asserts an acknowledge by pulling SDA low.
9. The addressed slave places 8-bits of data on the bus from the location specified by the register pointer.
10. The master issues an acknowledge (A) signaling the slave that it wishes to receive more data.
11. Steps 9 to 10 are repeated as many times as the master requires. Following the last byte of data, the master must issue a not acknowledge (nA) to signal that it wishes to stop receiving data.
12. The master sends a stop condition (P) or a repeated start condition (Sr). Issuing a stop (P) ensures that the bus input filters are set for 1MHz or slower operation. Issuing an Sr leaves the bus input filters in their current state.

Note that when this device receives a stop, it does not modify its register pointer. Therefore, if the master re-reads the same register, it can immediately send another read command, omitting the command to send a register pointer.

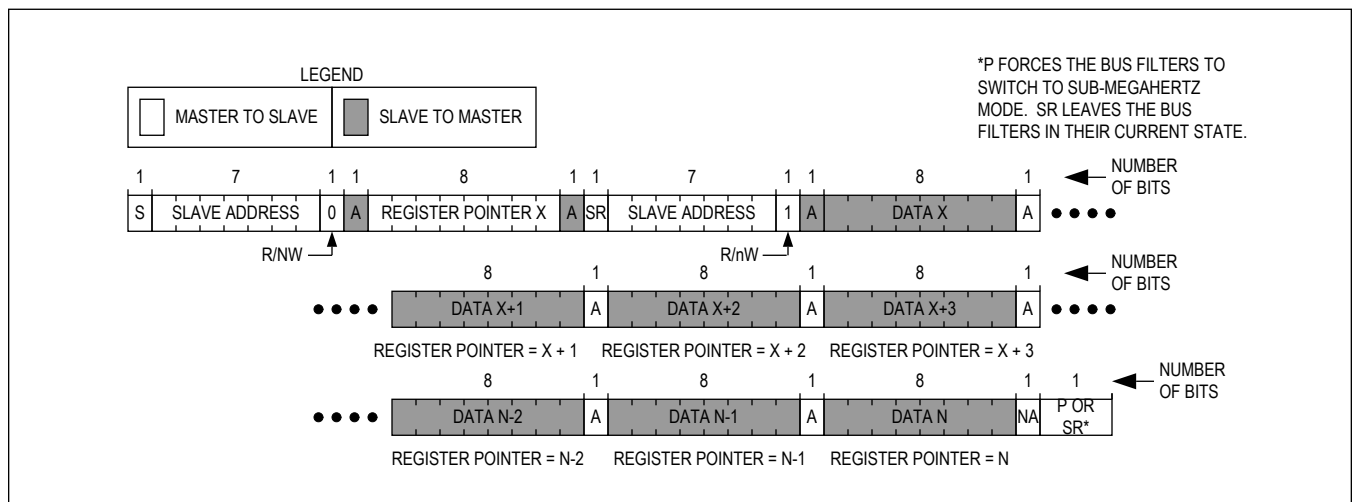

Figure 26. Reading Continuously from Sequential Registers X to N

Engaging HS-Mode for Operation up to 3.4MHz

Figure 27 shows the protocol for engaging HS-mode operation. HS-mode operation allows for a bus operating speed up to 3.4MHz. The engaging HS-mode protocol is as follows:

1. Begin the protocol while operating at a bus speed of 1MHz or lower.
2. The master sends a start command (S).
3. The master sends the 8-bit master code of 0b0000 1XXX where 0bXXX are don't care bits.
4. The addressed slave issues a not acknowledge (nA).
5. The master can increase its bus speed up to 3.4MHz and issue any read/write operation.

The master may continue to issue high-speed read/write operations until a stop (P) is issued. To continue operations in high-speed mode, use repeated start (Sr)

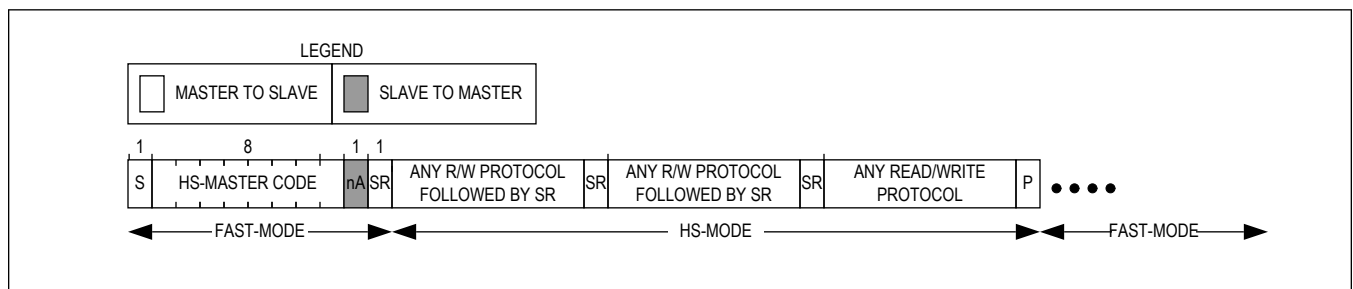

Figure 27. Engaging HS Mode

Register Map

MAX77643

ADDRESS	NAME	MSB							LSB	
Global										
0x00	INT_GLBL0[7:0]	RSVD	DOD_R	TJAL2_R	TJAL1_R	nEN_R	nEN_F	GPI0_R	GPI0_F	
0x01	INT_GLBL1[7:0]	RSVD	RSVD	LDO_F	SBB2_F	SBB1_F	SBB0_F	GPI1_R	GPI1_F	
0x02	ERCFLAG[7:0]	SBB_FA ULT_F	WDT_EX P_F	SFT_CR ST_F	SFT_OF F_F	MRST_F	INUVLO	INOVLO	TOVLD	
0x03	STAT_GLBL[7:0]	DIDM	BOK	RSVD	DOD_S	TJAL2_S	TJAL1_S	STAT_E N	STAT_IR Q	
0x04	INTM_GLBL0[7:0]	RSVD	DOD_R M	TJAL2_R M	TJAL1_R M	nEN_RM	nEN_FM	GPI0_R M	GPI0_F M	
0x05	INTM_GLBL1[7:0]	RSVD	RSVD	LDO_M	SBB2_F M	SBB1_F M	SBB0_F M	GPI1_R M	GPI1_F M	
0x06	CNFG_GLBL0[7:0]	PU_DIS	MRST	SBIA_LP M	nEN_MODE[1:0]		DBEN_n EN	SFT_CTRL[1:0]		
0x07	CNFG_GLBL1[7:0]	RSVD[4:0]					SBB_F SHUTDN	AUTO_WKT[1:0]		
0x08	CNFG_GPIO0[7:0]	RSVD[1:0]		ALT_GPI O0	DBEN_G PI	DO	DRV	DI	DIR	
0x09	CNFG_GPIO1[7:0]	RSVD[1:0]		ALT_GPI O1	DBEN_G PI	DO	DRV	DI	DIR	
0x10	CID[7:0]	-	-	-	CID[4:0]					
0x17	CNFG_WDT[7:0]	RSVD[1:0]		WDT_PER[1:0]		WDT_M ODE	WDT_CL R	WDT_E N	WDT_LO CK	
SBB										
0x28	CNFG_SBB_TOP[7:0]	DIS_LP M	-	-	-	-	-	DRV_SBB[1:0]		
0x29	CNFG_SBB0_A[7:0]	TV_SBB0[7:0]								
0x2A	CNFG_SBB0_B[7:0]	OP_MODE[1:0]		IP_SBB0[1:0]		ADE_SB B0	EN_SBB0[2:0]			
0x2B	CNFG_SBB1_A[7:0]	TV_SBB1[7:0]								
0x2C	CNFG_SBB1_B[7:0]	OP_MODE[1:0]		IP_SBB1[1:0]		ADE_SB B1	EN_SBB1[2:0]			
0x2D	CNFG_SBB2_A[7:0]	TV_SBB2[7:0]								
0x2E	CNFG_SBB2_B[7:0]	OP_MODE[1:0]		IP_SBB2[1:0]		ADE_SB B2	EN_SBB2[2:0]			
0x2F	CNFG_DVS_SBB0_A[7:0]	TV_SBB0_DVS[7:0]								
LDO										
0x38	CNFG_LDO0_A[7:0]	TV_OFS LDO	TV_LDO[6:0]							
0x39	CNFG_LDO0_B[7:0]	RSVD[2:0]			LDO_MD	ADE_LD O	EN_LDO[2:0]			

Register Details

[INT_GLBL0 \(0x00\)](#)

BIT	7	6	5	4	3	2	1	0
Field	RSVD	DOD_R	TJAL2_R	TJAL1_R	nEN_R	nEN_F	GPI0_R	GPI0_F
Reset	0b0	0b0	0b0	0b0	0b0	0b0	0b0	0b0
Access Type	Read Clears All	Read Clears All	Read Clears All	Read Clears All	Read Clears All	Read Clears All	Read Clears All	Read Clears All

BITFIELD	BITS	DESCRIPTION	DECODE
RSVD	7	RSVD	
DOD_R	6	LDO Dropout Detector Rising Interrupt	0b0 = The LDO has not detected dropout since the last time this bit was read. 0b1 = The LDO has detected dropout since the last time this bit was read.
TJAL2_R	5	Thermal Alarm 2 Rising Interrupt	0b0 = The junction temperature has not risen above TJAL2 since the last time this bit was read. 0b1 = The junction temperature has risen above TJAL2 since the last time this bit was read.
TJAL1_R	4	Thermal Alarm 1 Rising Interrupt	0b0 = The junction temperature has not risen above TJAL1 since the last time this bit was read. 0b1 = The junction temperature has risen above TJAL1 since the last time this bit was read.
nEN_R	3	nEN Rising Interrupt	0b0 = No nEN rising edges have occurred since the last time this bit was read. 0b1 = A nEN rising edge has occurred since the last time this bit was read.
nEN_F	2	nEN Falling Interrupt	0b0 = No nEN falling edges have occurred since the last time this bit was read. 0b1 = A nEN falling edge occurred since the last time this bit was read.
GPI0_R	1	GPI Rising Interrupt Note that "GPI" refers to the GPIO programmed to be an input.	0b0 = No GPI rising edges have occurred since the last time this bit was read. 0b1 = A GPI rising edge has occurred since the last time this bit was read.
GPI0_F	0	GPI Falling Interrupt Note that the GPI is the GPIO programmed to be an input.	0b0 = No GPI falling edges have occurred since the last time this bit was read. 0b1 = A GPI falling edge has occurred since the last time this bit was read.

[INT_GLBL1 \(0x01\)](#)

BIT	7	6	5	4	3	2	1	0
Field	RSVD	RSVD	LDO_F	SBB2_F	SBB1_F	SBB0_F	GPI1_R	GPI1_F
Reset	0b000	0b000	0b0	0b0	0b0	0b0	0b0	0b0
Access Type	Read Clears All	Read Clears All	Read Clears All	Read Clears All	Read Clears All	Read Clears All	Read Clears All	Read Clears All
BITFIELD	BITS	DESCRIPTION	DECODE					
RSVD	7	Reserved. Unutilized bit. Write to 0. Reads are don't care.						

BITFIELD	BITS	DESCRIPTION	DECODE
RSVD	6	Reserved. Unutilized bit. Write to 0. Reads are don't care.	
LDO_F	5	LDO Fault Interrupt	0b0 = No fault has occurred on LDO since the last time this bit was read. 0b1 = LDO has fallen out of regulation since the last time this bit was read.
SBB2_F	4	SBB2 Fault Indicator	0b0 = No fault has occurred on SBB2 since the last time this bit was read. 0b1 = SBB2 has fallen out of regulation since the last time this bit was read.
SBB1_F	3	SBB1 Fault Indicator	0b0 = No fault has occurred on SBB1 since the last time this bit was read. 0b1 = SBB1 has fallen out of regulation since the last time this bit was read.
SBB0_F	2	SBB0 Fault Indicator	0b0 = No fault has occurred on SBB0 since the last time this bit was read. 0b1 = SBB0 has fallen out of regulation since the last time this bit was read.
GPI1_R	1	GPI1 Rising Interrupt Note that "GPI" refers to the GPIO programmed to be an input.	0b0 = No GPI1 rising edges have occurred since the last time this bit was read. 0b1 = A GPI1 rising edge has occurred since the last time this bit was read.
GPI1_F	0	GPI1 Falling Interrupt Note that the GPI is the GPIO programmed to be an input.	0b0 = No GPI1 falling edges have occurred since the last time this bit was read. 0b1 = A GPI1 falling edge has occurred since the last time this bit was read.

ERCFLAG (0x02)

BIT	7	6	5	4	3	2	1	0
Field	SBB_FAULT_F	WDT_EXP_F	SFT_CRST_F	SFT_OFF_F	MRST_F	INUVLO	INOVLO	TOVLD
Reset	0b0	0b0	0b0	0b0	0b0	0b0	0b0	0b0
Access Type	Read Clears All	Read Clears All	Read Clears All	Read Clears All	Read Clears All	Read Clears All	Read Clears All	Read Clears All

BITFIELD	BITS	DESCRIPTION	DECODE
SBB_FAULT_F	7	SBBx Fault and Shutdown Flag. This bit sets when a SBBx fault and consequent SBBx shutdown occurs.	0b0 = No SBB shutdown occurred since the last time this bit was read. 0b1 = SBBx fault and SBB shutdown occurred since the last time this bit was read.
WDT_EXP_F	6	Watchdog Timer OFF or RESET Flag. This bit sets when the watchdog timer expires and causes a power-off or a reset; based on WDT_MODE bitfield setting.	0b0 = Watchdog timer has not caused a power-off or reset since the last time this bit was read. 0b1 = Watchdog timer has expired and caused a power-off or reset since the last time this bit was read.
SFT_CRST_F	5	Software Cold Reset Flag	0b0 = The software cold reset has not occurred since the last read of this register. 0b1 = The software cold reset has occurred since the last read of this register. This indicates that software has set SFT_CTRL[1:0] = 0b01.

BITFIELD	BITS	DESCRIPTION	DECODE
SFT_OFF_F	4	Software OFF Flag	0b0 = The SFT_OFF function has not occurred since the last read of this register. 0b1 = The SFT_OFF function has occurred since the last read of this register. This indicates that software has set SFT_CTRL[1:0] = 0b10.
MRST_F	3	Manual Reset Timer	0b0 = A manual reset has not occurred since the last read of this register. 0b1 = A manual reset has occurred since the last read of this register.
INUVLO	2	IN Domain Undervoltage Lockout	0b0 = The IN domain undervoltage lockout has not occurred since the last read of this register. 0b1 = The IN domain undervoltage lockout has occurred since the last read of this register. This indicates that the IN domain voltage fell below V _{INUVLO} (~2.6V)
INOVLO	1	IN Domain Overvoltage Lockout	0b0 = The IN domain overvoltage lockout has not occurred since the last read of this register. 0b1 = The IN domain overvoltage lockout has occurred since the last read of this register. This indicates that the IN domain voltage rose above V _{INOVLO} (~5.85V)
TOVLD	0	Thermal Overload	0b0 = Thermal overload has not occurred since the last read of this register. 0b1 = Thermal overload has occurred since the last read of this register. This indicates that the junction temperature has exceeded +165°C.

STAT_GLBL (0x03)

BIT	7	6	5	4	3	2	1	0
Field	DIDM	BOK	RSVD	DOD_S	TJAL2_S	TJAL1_S	STAT_EN	STAT_IRQ
Reset	OTP	0b1	0b0	0b0	0b0	0b0	0b0	0b0
Access Type	Read Only	Read Only	Read Clears All	Read Only	Read Only	Read Only	Read Only	Read Only

BITFIELD	BITS	DESCRIPTION	DECODE
DIDM	7	Device Identification Bits for Metal Options	0b0 = MAX77643 0b1 = Reserved
BOK	6	BOK Interrupt Status	0b0 = Main bias is not ready. 0b1 = Main bias enabled and ready.
RSVD	5	Reserved. Unutilized bit. Write to 0. Reads are don't care.	
DOD_S	4	LDO Dropout Detector Rising Status	0b0 = LDO is not in dropout. 0b1 = LDO is in dropout.
TJAL2_S	3	Thermal Alarm 2 Status	0b0 = The junction temperature is less than TJA2. 0b1 = The junction temperature is greater than TJAL2.
TJAL1_S	2	Thermal Alarm 1 Status	0b0 = The junction temperature is less than TJAL1. 0b1 = The junction temperature is greater than TJAL1.
STAT_EN	1	Debounced Status for the nEN Input	0b0 = nEN is not active (logic high). 0b1 = nEN is active (logic low).

BITFIELD	BITS	DESCRIPTION	DECODE
STAT_IRQ	0	Software Version of the nIRQ MOSFET Gate Drive	0b0 = Unmasked gate drive is logic low. 0b1 = Unmasked gate drive is logic high.

INTM_GLBL0 (0x04)

BIT	7	6	5	4	3	2	1	0
Field	RSVD	DOD_RM	TJAL2_RM	TJAL1_RM	nEN_RM	nEN_FM	GPI0_RM	GPI0_FM
Reset	0b0	0b1	0b1	0b1	0b1	0b1	0b1	0b1
Access Type	Write, Read	Write, Read	Write, Read	Write, Read	Write, Read	Write, Read	Write, Read	Write, Read

BITFIELD	BITS	DESCRIPTION	DECODE
RSVD	7	Reserved. Unutilized bit. Write to 0. Reads are don't care.	
DOD_RM	6	LDO Dropout Detector Rising Interrupt Mask	0b0 = Unmasked. If DOD_R goes from 0 to 1, then nIRQ goes low. nIRQ goes high when all interrupt bits are cleared. 0b1 = Masked. nIRQ does not go low due to DOD_R.
TJAL2_RM	5	Thermal Alarm 2 Rising Interrupt Mask	0b0 = Unmasked. If TJAL2_R goes from 0 to 1, then nIRQ goes low. nIRQ goes high when all interrupt bits are cleared. 0b1 = Masked. nIRQ does not go low due to TJAL2_R.
TJAL1_RM	4	Thermal Alarm 1 Rising Interrupt Mask	0b0 = Unmasked. If TJAL1_R goes from 0 to 1, then nIRQ goes low. nIRQ goes high when all interrupt bits are cleared. 0b1 = Masked. nIRQ does not go low due to TJAL1_R.
nEN_RM	3	nEN Rising Interrupt Mask	0b0 = Unmasked. If nEN_R goes from 0 to 1, then nIRQ goes low. nIRQ goes high when all interrupt bits are cleared. 0b1 = Masked. nIRQ does not go low due to nEN_R.
nEN_FM	2	nEN Falling Interrupt Mask	0b0 = Unmasked. If nEN_F goes from 0 to 1, then nIRQ goes low. nIRQ goes high when all interrupt bits are cleared. 0b1 = Masked. nIRQ does not go low due to nEN_F.
GPI0_RM	1	GPI0 Rising Interrupt Mask	0b0 = Unmasked. If GPI0_R goes from 0 to 1, then nIRQ goes low. nIRQ goes high when all interrupt bits are cleared. 0b1 = Masked. nIRQ does not go low due to GPI0_R.
GPI0_FM	0	GPI0 Falling Interrupt Mask	0b0 = Unmasked. If GPI0_F goes from 0 to 1, then nIRQ goes low. nIRQ goes high when all interrupt bits are cleared. 0b1 = Masked. nIRQ does not go low due to GPI0_F.

[INTM_GLBL1 \(0x05\)](#)

BIT	7	6	5	4	3	2	1	0
Field	RSVD	RSVD	LDO_M	SBB2_FM	SBB1_FM	SBB0_FM	GPI1_RM	GPI1_FM
Reset	0b0	0b0	0b1	0b0	0b0	0b0	0b1	0b1
Access Type	Write, Read	Write, Read	Write, Read	Write, Read	Write, Read	Write, Read	Write, Read	Write, Read

BITFIELD	BITS	DESCRIPTION	DECODE
RSVD	7	Reserved. Unutilized bit. Write to 0. Reads are don't care.	
RSVD	6	Reserved. Unutilized bit. Write to 0. Reads are don't care.	
LDO_M	5	LDO Fault Interrupt Mask	0b0 = Unmasked. If LDO_F goes from 0 to 1, then nIRQ goes low. nIRQ goes high when all interrupt bits are cleared. 0b1 = Masked. nIRQ does not go low due to LDO_F.
SBB2_FM	4	SBB2 Fault Interrupt Mask	0b0 = Unmasked. If SBB2_F goes from 0 to 1, then nIRQ goes low. nIRQ goes high when all interrupt bits are cleared. 0b1 = Masked. nIRQ does not go low due to SBB2_F.
SBB1_FM	3	SBB1 Fault Interrupt Mask	0b0 = Unmasked. If SBB1_F goes from 0 to 1, then nIRQ goes low. nIRQ goes high when all interrupt bits are cleared. 0b1 = Masked. nIRQ does not go low due to SBB1_F.
SBB0_FM	2	SBB0 Fault Interrupt Mask	0b0 = Unmasked. If SBB0_F goes from 0 to 1, then nIRQ goes low. nIRQ goes high when all interrupt bits are cleared. 0b1 = Masked. nIRQ does not go low due to SBB0_F.
GPI1_RM	1	GPI1 Rising Interrupt Mask	0b0 = Unmasked. If GPI1_R goes from 0 to 1, then nIRQ goes low. nIRQ goes high when all interrupt bits are cleared. 0b1 = Masked. nIRQ does not go low due to GPI1_R.
GPI1_FM	0	GPI1 Falling Interrupt Mask	0b0 = Unmasked. If GPI1_F goes from 0 to 1, then nIRQ goes low. nIRQ goes high when all interrupt bits are cleared. 0b1 = Masked. nIRQ does not go low due to GPI1_F.

[CNFG_GLBL0 \(0x06\)](#)

BIT	7	6	5	4	3	2	1	0
Field	PU_DIS	MRST	SBIA_LPM	nEN_MODE[1:0]		DBEN_nEN	SFT_CTRL[1:0]	
Reset	OTP	OTP	OTP	OTP		OTP	0b00	
Access Type	Write, Read	Write, Read	Write, Read	Write, Read		Write, Read	Write, Read	

BITFIELD	BITS	DESCRIPTION	DECODE
PU_DIS	7	nEN Internal Pullup Resistor	0b0 = Strong internal nEN pullup (200kΩ) 0b1 = Weak internal nEN pullup (10MΩ)
MRST	6	Sets the Manual Reset Time (t _{MRST})	0b0 = 8s 0b1 = 4s
SBIA_LPM	5	Main Bias Power Mode	0b0 = Main bias is in normal-power mode by software. 0b1 = Main bias is in low-power mode by software.
nEN_MODE	4:3	nEN Input (ON-KEY) Default Configuration Mode	0b00 = Push-button mode 0b01 = Slide-switch mode 0b10 = Logic mode 0b11 = Reserved
DBEN_nEN	2	Debounce Timer Enable for the nEN Pin	0b0 = 500μs Debounce 0b1 = 30ms Debounce Applies only to push button and slide switch Mmode
SFT_CTRL	1:0	Software Reset Functions Note that the SFT_CRST and SFT_OFF commands initiate the power-down sequence flow as described in the data sheet. This power-down sequence flow has delay elements that add up to 205.24ms (60ms delay + 10.24ms nRST assert delay + 4x2.56ms power-down slot delays + 125ms output discharge delay). If issuing the SFT_CRST and/or SFT_OFF functions in software, wait for more than 300ms before trying to issue any additional commands through I ² C.	0b00 = No action 0b01 = Software cold reset (SFT_CRST). The device powers down, resets, and then powers up again. 0b10 = Software off (SFT_OFF). The device powers down, resets, and then remains off and waiting for a wake-up event. 0b11 = Auto Wake Up (SFT_AUTO) The device powers down, and then automatically starts power up sequence after time determined in AUTO_WKT. Note that the registers do not get reset with Auto Wake Up.

CNFG_GLBL1 (0x07)

BIT	7	6	5	4	3	2	1	0
Field	RSVD[4:0]					SBB_F_SH UTDN	AUTO_WKT[1:0]	
Reset	0b0000					0b0	0x00	
Access Type	Write, Read					Write, Read	Write, Read	

BITFIELD	BITS	DESCRIPTION	DECODE
RSVD	7:3	Reserved. Unutilized bit. Write to 0. Reads are don't care.	
SBB_F_SHU TDN	2	SBB Shutdown from SBB Fault	0b0 = The SBB regulators do not shut off when an SBB fault occurs. 0b1 = The SBB regulators powers down sequentially when a SBB fault occurs.
AUTO_WKT	1:0	Auto Wake-Up Timer	0b00 = 100ms Auto Wake-up Time 0b01 = 200ms Auto Wake-up Time 0b10 = 500ms Auto Wake-up Time 0b11 = 1000ms Auto Wake-up Time

[CNFG_GPIO0 \(0x08\)](#)

BIT	7	6	5	4	3	2	1	0
Field	RSVD[1:0]		ALT_GPIO0	DBEN_GPI	DO	DRV	DI	DIR
Reset	0b0		OTP	0b0	0b0	0b0	0b0	0b1
Access Type	Write, Read		Write, Read	Write, Read	Write, Read	Write, Read	Read Only	Write, Read

BITFIELD	BITS	DESCRIPTION	DECODE
RSVD	7:6	Reserved. Unutilized bit. Write to 0. Reads are don't care.	
ALT_GPIO0	5	Alternate Mode Enable for GPIO0	0b0 = Standard GPIO 0b1 = GPIO controls whether SBB0 is set by TV_SBB0 or TV_SBB0_DVS
DBEN_GPI	4	General Purpose Input Debounce Timer Enable	0b0 = No debounce 0b1 = 30ms debounce
DO	3	General Purpose Output Data Output	This bit is a don't care when DIR = 1 (configured as input). When set for GPO (DIR = 0): 0b0 = GPIO is output logic low. 0b1 = GPIO is output logic high when set as push-pull output (DRV = 1). GPIO is high-impedance when set as an open-drain output (DRV = 0).
DRV	2	General Purpose Output Driver Type	This bit is a don't care when DIR = 1 (configured as input). When set for GPO (DIR = 0): 0b0 = Open-drain 0b1 = Push-pull
DI	1	GPIO Digital Input Value. Irrespective of whether the GPIO is set for GPI (DIR = 1) or GPO (DIR = 0), DI reflects the state of the GPIO.	0b0 = Input logic low 0b1 = Input logic high
DIR	0	GPIO Direction	0b0 = General purpose output (GPO) 0b1 = General purpose input (GPI)

[CNFG_GPIO1 \(0x09\)](#)

BIT	7	6	5	4	3	2	1	0
Field	RSVD[1:0]		ALT_GPIO1	DBEN_GPI	DO	DRV	DI	DIR
Reset	0b00		OTP	0b0	0b0	0b0	0b0	0b1
Access Type	Write, Read		Write, Read	Write, Read	Write, Read	Write, Read	Read Only	Write, Read

BITFIELD	BITS	DESCRIPTION	DECODE
RSVD	7:6	Reserved. Unutilized bit. Write to 0. Reads are don't care.	
ALT_GPIO1	5	Alternate Mode Enable for GPIO1	0b0 = Standard GPIO 0b1 = Flexible power sequencer active-high output for SBB2.
DBEN_GPI	4	General Purpose Input Debounce Timer Enable	0b0 = No debounce 0b1 = 30ms debounce

BITFIELD	BITS	DESCRIPTION	DECODE
DO	3	General Purpose Output Data Output	This bit is a don't care when DIR = 1 (configured as input). When set for GPO (DIR = 0): 0b0 = GPIO is output logic low. 0b1 = GPIO is output logic high when set as push-pull output (DRV = 1). GPIO is high-impedance when set as an open-drain output (DRV = 0).
DRV	2	General Purpose Output Driver Type	This bit is a don't care when DIR = 1 (configured as input). When set for GPO (DIR = 0): 0b0 = Open-drain 0b1 = Push-pull
DI	1	GPIO Digital Input Value. Irrespective of whether the GPIO is set for GPI (DIR = 1) or GPO (DIR = 0), DI reflects the state of the GPIO.	0b0 = Input logic low 0b1 = Input logic high
DIR	0	GPIO Direction	0b0 = General purpose output (GPO) 0b1 = General purpose input (GPI)

CID (0x10)

BIT	7	6	5	4	3	2	1	0
Field	–	–	–	CID[4:0]				
Reset	–	–	–	OTP				
Access Type	–	–	–	Read Only				

BITFIELD	BITS	DESCRIPTION
CID	4:0	Chip Identification Code The chip identification code refers to a set of reset values in the register map, or the "OTP configuration."

CNFG_WDT (0x17)

BIT	7	6	5	4	3	2	1	0
Field	RSVD[1:0]		WDT_PER[1:0]		WDT_MOD E	WDT_CLR	WDT_EN	WDT_LOC K
Reset	0b00		0b11		0b0	0b0	OTP	OTP
Access Type	Write, Read		Write, Read		Write, Read	Write, Read	Write, Read	Read Only

BITFIELD	BITS	DESCRIPTION	DECODE
RSVD	7:6	Reserved. Unutilized bit. Write to 0. Reads are don't care.	
WDT_PER	5:4	Watchdog Timer Period. Sets t_{WD} . Watchdog timer is reset to the programmed value as soon as this bitfield is changed.	0b00 = 16 seconds 0b01 = 32 seconds 0b10 = 64 seconds 0b11 = 128 seconds

BITFIELD	BITS	DESCRIPTION	DECODE
WDT_MODE	3	Watchdog Timer Expired Action. Determines what the IC does after the watchdog timer expires.	0b0 = Watchdog timer expire causes power-off. 0b1 = Watchdog timer expire causes power reset.
WDT_CLR	2	Watchdog Timer Clear Control. Set this bit to feed (reset) the watchdog timer.	0b0 = Watchdog timer period is not reset. 0b1 = Watchdog timer is reset back to t_{WD} .
WDT_EN	1	Watchdog Timer Enable. Write protected depending on WDT_LOCK.	0b0 = Watchdog timer is not enabled. 0b1 = Watchdog timer is enabled. The timer expires if not reset by setting WDT_CLR.
WDT_LOCK	0	Factory-Set Safety Bit for the Watchdog Timer. Determines if the timer can be disabled through WDT_EN or not.	0b0 = Watchdog timer can be enabled and disabled with WDT_EN. 0b1 = Watchdog timer can not be disabled with WDT_EN. However, WDT_EN can still be used to enable the watchdog timer.

CNFG_SBB_TOP (0x28)

BIT	7	6	5	4	3	2	1	0
Field	DIS_LPM	–	–	–	–	–	DRV_SBB[1:0]	
Reset	0b0	–	–	–	–	–	OTP	
Access Type	Write, Read	–	–	–	–	–	Write, Read	

BITFIELD	BITS	DESCRIPTION	DECODE
DIS_LPM	7	Disables the Automatic Low-Power Mode for Each SIMO Channel.	0b0 = Automatic low power mode for each SIMO channel 0b1 = Disable low power mode feature for each SIMO channel
DRV_SBB	1:0	SIMO Buck-Boost (All Channels) Drive Strength Trim. See the <i>Drive Strength</i> section for more details.	0b00 = Fastest transition time 0b01 = A little slower than 0b00 0b10 = A little slower than 0b01 0b11 = A little slower than 0b10

CNFG_SBB0_A (0x29)

BIT	7	6	5	4	3	2	1	0
Field	TV_SBB0[7:0]							
Reset	OTP							
Access Type	Write, Read							

BITFIELD	BITS	DESCRIPTION	DECODE
TV_SBB0	7:0	SIMO Buck-Boost Channel 0 Target Output Voltage This 8-bit configuration is a linear transfer function that starts at 0.5V and ends at 5.5V with 25mV increments.	0x00 = 0.500V 0x01 = 0.525V 0x02 = 0.550V 0x03 = 0.575V 0x04 = 0.600V 0x05 = 0.625V 0x06 = 0.650V 0x07 = 0.675V 0x08 = 0.700V ... 0xC5 = 5.425V 0xC6 = 5.450V 0xC7 = 5.475V 0xC8 to 0xFF = 5.500V

CNFG_SBB0_B (0x2A)

BIT	7	6	5	4	3	2	1	0
Field	OP_MODE[1:0]		IP_SBB0[1:0]		ADE_SBB0	EN_SBB0[2:0]		
Reset	OTP		OTP		OTP	OTP		
Access Type	Write, Read		Write, Read		Write, Read	Write, Read		

BITFIELD	BITS	DESCRIPTION	DECODE
OP_MODE	7:6	Operation Mode of SBB0	0b00 = Automatic 0b01 = Buck mode 0b10 = Boost mode 0b11 = Buck-boost mode
IP_SBB0	5:4	SIMO Buck-Boost Channel 0 Peak Current Limit	0b00 = 1.000A 0b01 = 0.750A 0b10 = 0.500A 0b11 = 0.333A
ADE_SBB0	3	SIMO Buck-Boost Channel 0 Active-Discharge Enable	0b0 = The active discharge function is disabled. When SBB0 is disabled, its discharge rate is a function of the output capacitance and the external load. 0b1 = The active discharge function is enabled. When SBB0 is disabled, an internal resistor (RAD_SBB0) is activated from SBB0 to PGND to help the output voltage discharge. The output voltage discharge rate is a function of the output capacitance, the external loading, and the internal RAD_SBB0 load.
EN_SBB0	2:0	Enable Control for SIMO Buck-Boost Channel 0. Select the FPS slot that the channel powers up and powers down in or whether the channel is forced on or off. Prior to enabling the SIMO, program the bias circuits to normal-power mode (SBIA_LPM = 0). After the SIMO is enabled, the bias circuits may be programmed back to low-power mode (SBIA_LPM = 1) to decrease quiescent current.	0b000 = FPS slot 0 0b001 = FPS slot 1 0b010 = FPS slot 2 0b011 = FPS slot 3 0b100 = Off irrespective of FPS 0b101 = Same as 0b100 0b110 = On irrespective of FPS 0b111 = Same as 0b110

[CNFG_SBB1_A \(0x2B\)](#)

BIT	7	6	5	4	3	2	1	0
Field	TV_SBB1[7:0]							
Reset	OTP							
Access Type	Write, Read							

BITFIELD	BITS	DESCRIPTION	DECODE
TV_SBB1	7:0	SIMO Buck-Boost Channel 1 Target Output Voltage This 8-bit configuration is a linear transfer function that starts at 0.5V and ends at 5.5V with 25mV increments.	0x00 = 0.500V 0x01 = 0.525V 0x02 = 0.550V 0x03 = 0.575V 0x04 = 0.600V 0x05 = 0.625V 0x06 = 0.650V 0x07 = 0.675V 0x08 = 0.700V ... 0xC5 = 5.425V 0xC6 = 5.450V 0xC7 = 5.475V 0xC8 to 0xFF = 5.500V

[CNFG_SBB1_B \(0x2C\)](#)

BIT	7	6	5	4	3	2	1	0
Field	OP_MODE[1:0]		IP_SBB1[1:0]		ADE_SBB1	EN_SBB1[2:0]		
Reset	OTP		OTP		OTP	OTP		
Access Type	Write, Read		Write, Read		Write, Read	Write, Read		

BITFIELD	BITS	DESCRIPTION	DECODE
OP_MODE	7:6	Operation Mode of SBB1	0b00 = Automatic 0b01 = Buck mode 0b10 = Boost mode 0b11 = Buck-boost mode
IP_SBB1	5:4	SIMO Buck-Boost Channel 1 Peak Current Limit	0b00 = 1.000A 0b01 = 0.750A 0b10 = 0.500A 0b11 = 0.333A
ADE_SBB1	3	SIMO Buck-Boost Channel 1 Active-Discharge Enable	0b0 = The active discharge function is disabled. When SBB1 is disabled, its discharge rate is a function of the output capacitance and the external load. 0b1 = The active discharge function is enabled. When SBB1 is disabled, an internal resistor (RAD_SBB1) is activated from SBB1 to PGND to help the output voltage discharge. The output voltage discharge rate is a function of the output capacitance, the external loading, and the internal RAD_SBB1 load.

BITFIELD	BITS	DESCRIPTION	DECODE
EN_SBB1	2:0	<p>Enable Control for SIMO Buck-Boost Channel 1. Select the FPS slot that the channel powers up and powers down in or whether the channel is forced on or off.</p> <p>Prior to enabling the SIMO, program the bias circuits to normal-power mode (SBIA_LPM = 0). After the SIMO is enabled, the bias circuits may be programmed back to low-power mode (SBIA_LPM = 1) to decrease quiescent current.</p>	<p>0b000 = FPS slot 0 0b001 = FPS slot 1 0b010 = FPS slot 2 0b011 = FPS slot 3 0b100 = Off irrespective of FPS 0b101 = Same as 0b100 0b110 = On irrespective of FPS 0b111 = Same as 0b110</p>

CNFG_SBB2_A (0x2D)

BIT	7	6	5	4	3	2	1	0
Field	TV_SBB2[7:0]							
Reset	OTP							
Access Type	Write, Read							

BITFIELD	BITS	DESCRIPTION	DECODE
TV_SBB2	7:0	<p>SIMO Buck-Boost Channel 2 Target Output Voltage</p> <p>This 8-bit configuration is a linear transfer function that starts at 0.5V and ends at 5.5V with 25mV increments.</p>	<p>0x00 = 0.500V 0x01 = 0.525V 0x02 = 0.550V 0x03 = 0.575V 0x04 = 0.600V 0x05 = 0.625V 0x06 = 0.650V 0x07 = 0.675V 0x08 = 0.700V ... 0xC5 = 5.425V 0xC6 = 5.450V 0xC7 = 5.475V 0xC8 to 0xFF = 5.500V</p>

CNFG_SBB2_B (0x2E)

BIT	7	6	5	4	3	2	1	0
Field	OP_MODE[1:0]		IP_SBB2[1:0]		ADE_SBB2	EN_SBB2[2:0]		
Reset	OTP		OTP		OTP	OTP		
Access Type	Write, Read		Write, Read		Write, Read	Write, Read		

BITFIELD	BITS	DESCRIPTION	DECODE
OP_MODE	7:6	Operation Mode of SBB2	<p>0b00 = Automatic 0b01 = Buck mode 0b10 = Boost mode 0b11 = Buck-boost mode</p>
IP_SBB2	5:4	SIMO Buck-Boost Channel 2 Peak Current Limit	<p>0b00 = 1.000A 0b01 = 0.750A 0b10 = 0.500A 0b11 = 0.333A</p>

BITFIELD	BITS	DESCRIPTION	DECODE
ADE_SBB2	3	SIMO Buck-Boost Channel 2 Active-Discharge Enable	0b0 = The active discharge function is disabled. When SBB2 is disabled, its discharge rate is a function of the output capacitance and the external load. 0b1 = The active discharge function is enabled. When SBB2 is disabled, an internal resistor (RAD_SBB2) is activated from SBB2 to PGND to help the output voltage discharge. The output voltage discharge rate is a function of the output capacitance, the external loading, and the internal RAD_SBB2 load.
EN_SBB2	2:0	Enable Control for SIMO Buck-Boost Channel 2. Select the FPS slot that the channel powers up and powers down in or whether the channel is forced on or off. Prior to enabling the SIMO, program the bias circuits to normal power mode (SBIA_LPM = 0). After the SIMO is enabled, the bias circuits may be programmed back to low power mode (SBIA_LPM = 1) to decrease quiescent current.	0b000 = FPS slot 0 0b001 = FPS slot 1 0b010 = FPS slot 2 0b011 = FPS slot 3 0b100 = Off irrespective of FPS 0b101 = Same as 0b100 0b110 = On irrespective of FPS 0b111 = Same as 0b110

CNFG_DVS_SBB0_A (0x2F)

BIT	7	6	5	4	3	2	1	0
Field	TV_SBB0_DVS[7:0]							
Reset	0x14							
Access Type	Write, Read							

BITFIELD	BITS	DESCRIPTION	DECODE
TV_SBB0_DVS	7:0	SIMO Buck-Boost Channel 0 Target Output Voltage This 7-bit configuration is a linear transfer function that starts at 0.5V and ends at 5.5V with 25mV increments.	0x00 = 0.500V 0x01 = 0.525V 0x02 = 0.550V 0x03 = 0.575V 0x04 = 0.600V 0x05 = 0.625V 0x06 = 0.650V 0x07 = 0.675V 0x08 = 0.700V ... 0xC5 = 5.425V 0xC6 = 5.450V 0xC7 = 5.475V 0xC8 to 0xFF = 5.500V

CNFG_LDO0_A (0x38)

BIT	7	6	5	4	3	2	1	0
Field	TV_OFS_LDO	TV_LDO[6:0]						
Reset	0xOTP	OTP						
Access Type	Write, Read	Write, Read						

BITFIELD	BITS	DESCRIPTION	DECODE
TV_OFS_LDO	7	LDO Output Voltage. This bit applies a 1.325V offset to the output voltage of the LDO.	0b0 = No Offset 0b1 = 1.325V Offset
TV_LDO	6:0	LDO Target Output Voltage This 7-bit configuration is a linear transfer function that starts at 0.5V and ends at 3.675V with 25mV increments.	0x00 = 0.500V 0x01 = 0.525V 0x02 = 0.550V 0x03 = 0.575V 0x04 = 0.600V 0x05 = 0.625V 0x06 = 0.650V 0x07 = 0.675V 0x08 = 0.700V ... 0x7E = 3.650V 0x7F = 3.675V When TV_LDO[7] = 0, TV_LDO[6:0] sets the LDO's output voltage range from 0.5V to 3.675V. When TV_LDO[7] = 1, TV_LDO[6:0] sets the LDO's output voltage from 1.825V to 5V.

CNFG_LDO0_B (0x39)

BIT	7	6	5	4	3	2	1	0
Field	RSVD[2:0]			LDO_MD	ADE_LDO	EN_LDO[2:0]		
Reset	0b0			OTP	OTP	OTP		
Access Type	Write, Read			Write, Read	Write, Read	Write, Read		

BITFIELD	BITS	DESCRIPTION	DECODE
RSVD	7:5	Reserved. Unutilized bit. Write to 0. Reads are don't care.	
LDO_MD	4	Operation Mode of LDO	0b0 = Low dropout linear regulator (LDO) mode 0b1 = Load switch (LSW) mode
ADE_LDO	3	LDO Active-Discharge Enable	0b0 = The active discharge function is disabled. When LDO0 is disabled, its discharge rate is a function of the output capacitance and the external load. 0b1 = The active discharge function is enabled. When LDO is disabled, an internal resistor (RAD_LDO) is activated from LDO to GND to help the output voltage discharge. The output voltage discharge rate is a function of the output capacitance, the external loading, and the internal RAD_LDO load.

BITFIELD	BITS	DESCRIPTION	DECODE
EN_LDO	2:0	Enable Control for LDO. Select the FPS slot that the channel powers up and powers down in or whether the channel is forced on or off.	0b000 = FPS slot 0 0b001 = FPS slot 1 0b010 = FPS slot 2 0b011 = FPS slot 3 0b100 = Off irrespective of FPS 0b101 = Same as 0b100 0b110 = On irrespective of FPS 0b111 = Same as 0b110

Typical Application Circuits

Typical Applications Circuit

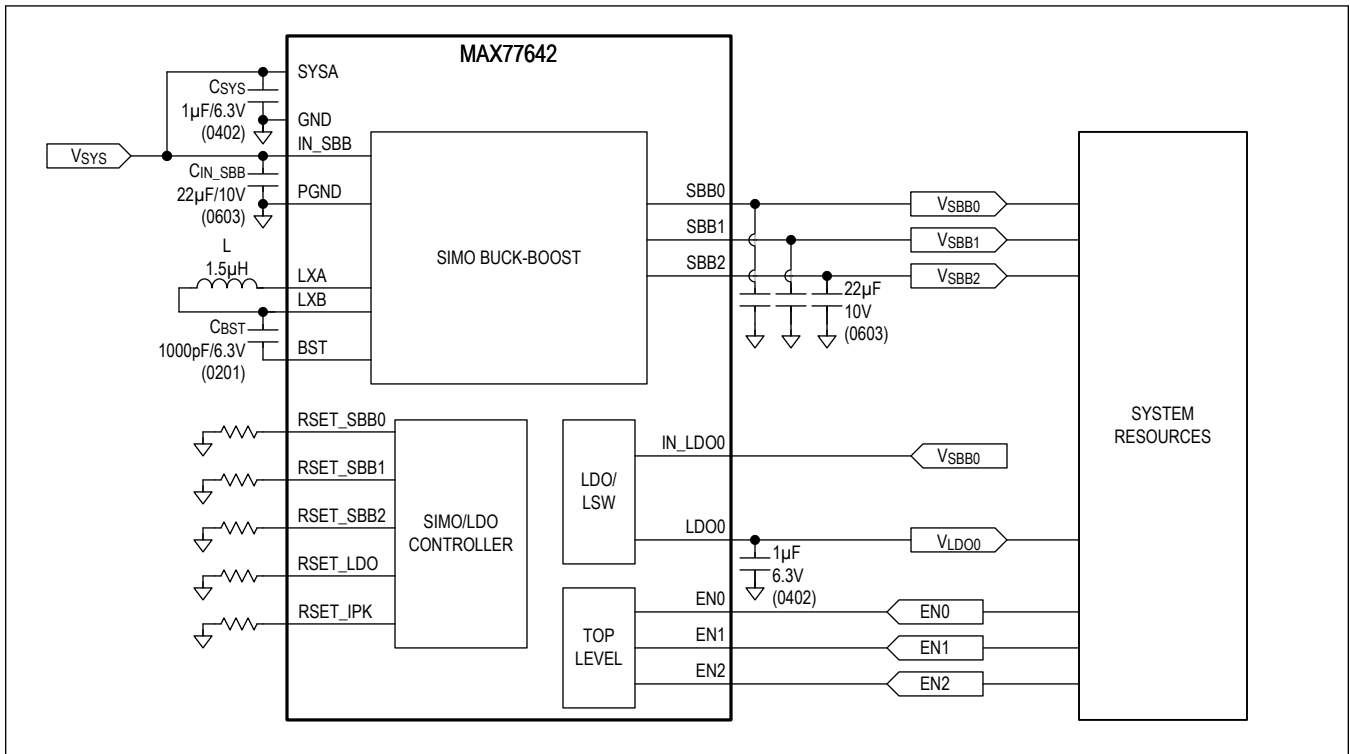

Figure 28. Typical Applications Circuit - R_{SEL} Version (MAX77642)

Typical Application Circuits (continued)

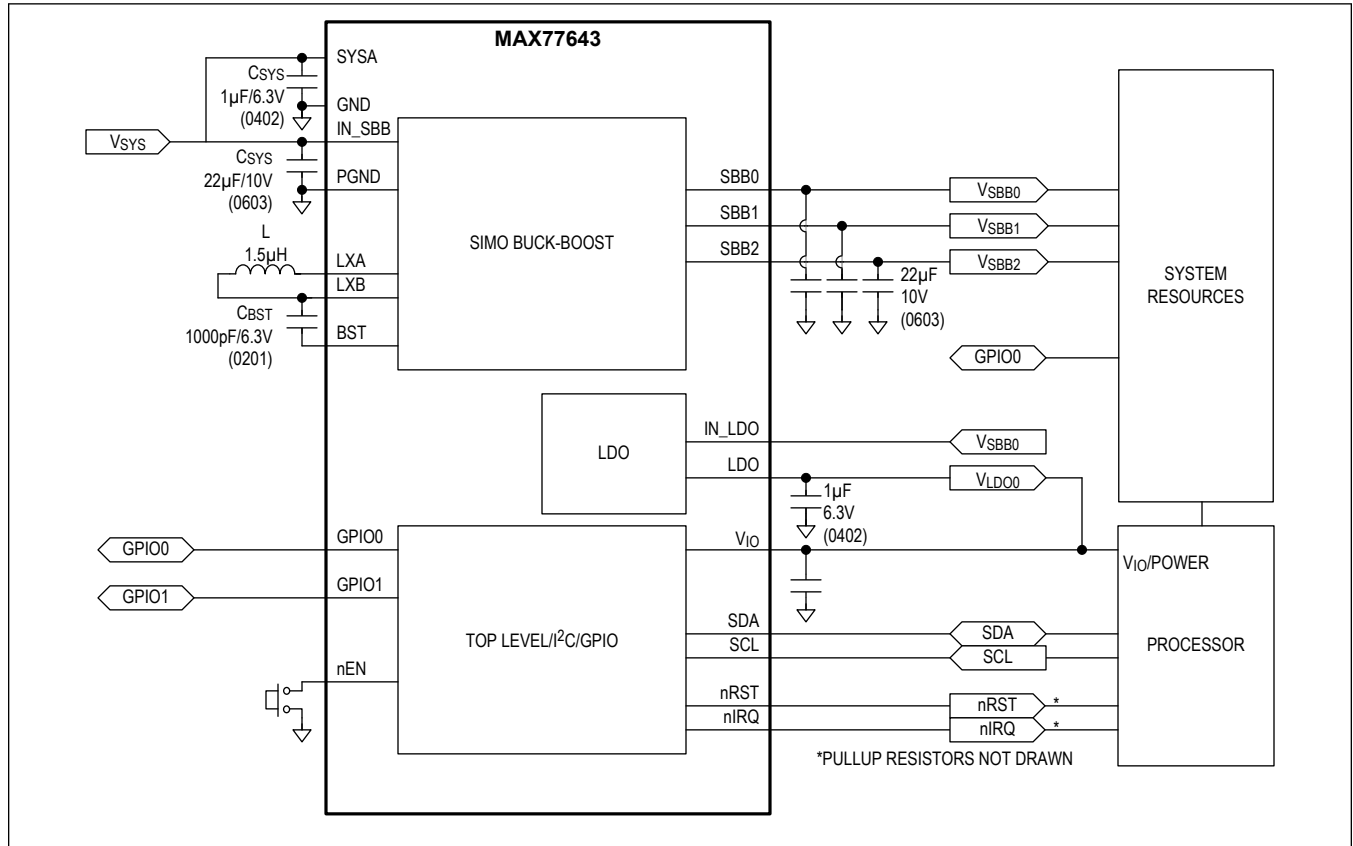

Figure 29. Typical Applications Circuit - I²C Version (MAX77643)

Ordering Information

PART	TEMP RANGE	PIN-PACKAGE	OPTIONS
MAX77642ANA+T	-40°C to +125°C	25 WLP	—
MAX77643ANA+T*	-40°C to +125°C	25 WLP	—
MAX77643AANA+T	-40°C to +125°C	25 WLP	Table 3
MAX77643SANA+T	-40°C to +125°C	25 WLP	Table 3
MAX77643BANA+T	-40°C to +125°C	25 WLP	Table 3
MAX77643CANA+T	-40°C to +125°C	25 WLP	Table 3
MAX77643EANA+T	-40°C to +125°C	25 WLP	Table 3
MAX77643DANA+T	-40°C to +125°C	25 WLP	Table 3

+Denotes a lead(Pb)-free/RoHS-compliant package.

T = Tape and reel.

*Custom samples only. Not for production or stock. Contact factory for more information.

Revision History

REVISION NUMBER	REVISION DATE	DESCRIPTION	PAGES CHANGED
0	8/20	Initial release	—
1	10/20	Updated the <i>Ordering Information</i> table	88
2	4/21	Updated Table 3, <i>Register Map</i> tables, and <i>Ordering Information</i> table	28, 72, 79, 80, 86, 87
3	5/21	Updated Figure 1, Table 3, <i>Register Details</i> , and <i>Ordering Information</i> table	27–29, 73, 84
4	10/21	Updated <i>Electrical Characteristics</i> — <i>SIMO Buck-Boost</i> table, Table 3, Figure 9, <i>Register Map</i> , and <i>Register Details</i>	13, 28, 29, 42, 73, 75