



CLICKER 2 PIC18FJ

all the inventions waiting to happen...

A compact starter kit
with your favorite
microcontroller and two
mikroBUS™ sockets

TO OUR VALUED CUSTOMERS

I want to express my thanks to you for being interested in our products and for having confidence in MikroElektronika.

The primary aim of our company is to design and produce high quality electronic products and to constantly improve the performance thereof in order to better suit your needs.

A handwritten signature in white ink, appearing to read 'N. Matic', is positioned on the right side of the page. The signature is fluid and cursive, with a large initial 'N' and 'M'.

Nebojsa Matic
General Manager

Table of contents

Introduction to clicker 2 for PIC18FJ	4	3.2 Programming with mikroProg™ programmer	15
Key features	5	mikroProg Suite™ for PIC® software	16
1. Power supply	7	4. Buttons and LEDs	18
2. PIC18F87J50 microcontroller	9	5. Power management and battery charger	20
Key microcontroller features	9	6. Oscillators	21
3. Programming the microcontroller	10	7. USB connection	23
3.1 Programming with mikroBootloader	11	8. Pads	25
step 1 - Connecting clicker 2 for PIC18FJ	11	9. Pinout	26
step 2 - Browsing for .HEX file	12	9.1 mikroBUS™ pinout	27
step 3 - Selecting .HEX file	12	10. click boards™ are plug and play!	28
step 4 - Uploading .HEX file	13	11. Dimensions	30
step 5 - Finish upload	14		

Introduction to clicker 2 for PIC18FJ

clicker 2 for PIC18FJ is a compact dev. kit with two mikroBUS™ sockets for click board connectivity. You can use it to quickly build your own gadgets with unique functionalities and features. It carries the PIC18F87J50, a 8-bit microcontroller, two indication LEDs, two general purpose buttons, a reset button, an on/off switch, a li-polymer battery connector, a USB Mini-B connector and two mikroBUS™ sockets. A mikroProg connector and a 2x26 pinout for interfacing with external electronics are also provided. The mikroBUS™ connector consists of two 1x8 female headers with **SPI**, **I²C**, **UART**, **RST**, **PWM**, **Analog** and **Interrupt** lines as well as **3.3V**, **5V** and **GND** power lines. **clicker 2 for PIC18FJ** board can be powered over a USB cable.

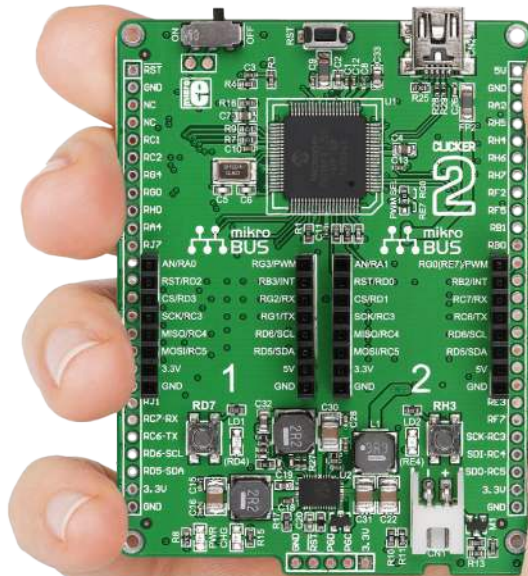

Key features

- 1 ON/OFF switch
- 2 Pads for connecting external ON/OFF switch
- 3 8 MHz crystal oscillator
- 4 two 1x26 connection pads
- 5 mikroBUS™ sockets 1 and 2
- 6 Pushbuttons
- 7 Additional LEDs
- 8 LTC3586 USB power manager IC
- 9 Power and Charge indication LEDs
- 10 RESET button
- 11 USB mini-B connector
- 12 PIC18F87J50
- 13 PWM selection jumper
- 14 Li-Polymer battery connector
- 15 mikroProg™ programmer connector

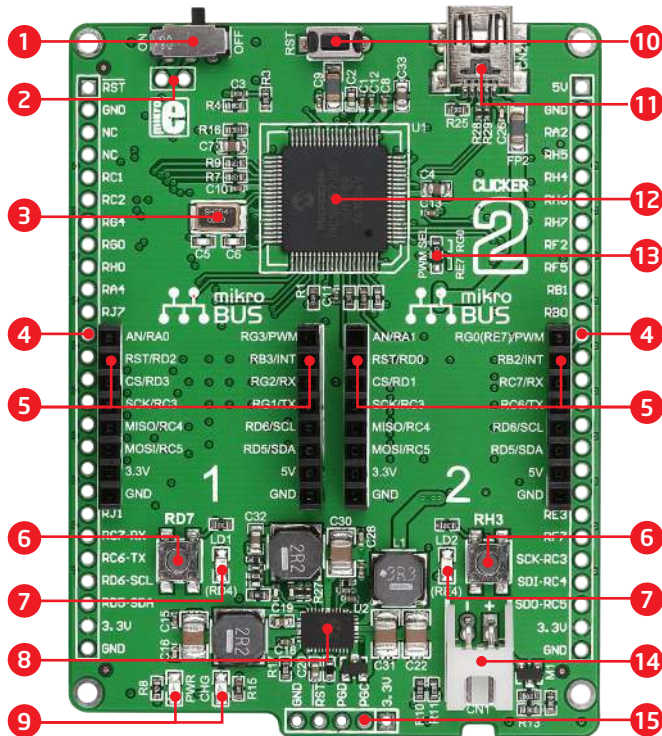

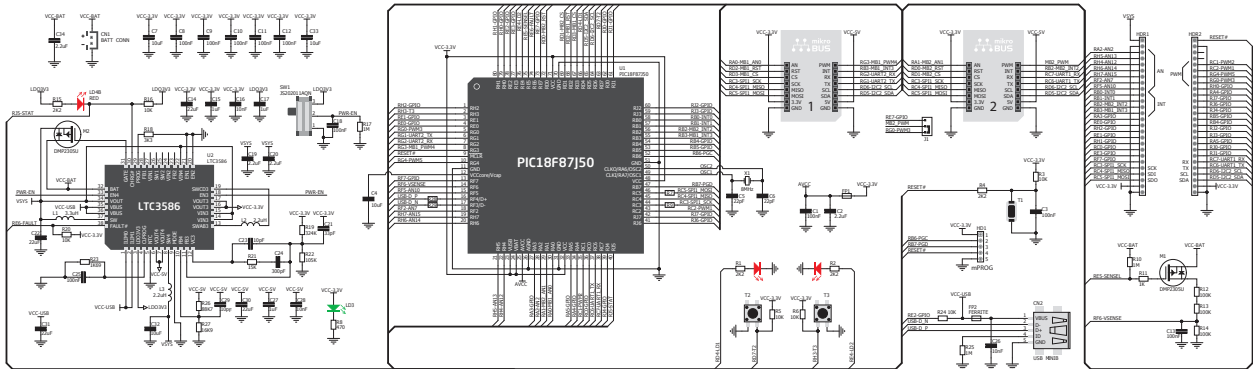

clicker 2 for PIC18FJ schematic

1. Power supply

Figure 1-1: Connecting USB power supply



USB power supply

You can supply power to the board with a **Mini-B USB** cable provided in the package. On-board voltage regulators provide the appropriate voltage levels to each component on the board. **Power LED (GREEN)** will indicate the presence of power supply.

NOTE | *Some click boards need more current than the USB connection can supply. For 3.3V clicks, the upper limit is 750 mA; for 5V clicks, it's 500 mA. In those cases you would need to use the battery as the power supply, or the vsys pin on the side of the board.*

Battery power supply

You can also power the board using a **Li-Polymer** battery, via on-board battery connector. On-board battery charger circuit enables you to charge the battery over USB connection. **LED diode (RED)** will indicate when battery is charging. Charging current is $\sim 300\text{mA}$ and charging voltage is 4.2V DC.

Figure 1-2: Connecting Li-Polymer battery



2. PIC18F87J50 microcontroller

The clicker 2 for PIC18FJ development tool comes with the **PIC18F87J50** device. This 8-bit low power high performance microcontroller is rich with on-chip peripherals and features 128 KB of program memory and 3094 bytes of RAM. It has integrated full speed USB 2.0. support.

Key microcontroller features

- Up to 12 MIPS operation
- 8-bit architecture
- 128 KB of program memory
- 3,904 bytes of RAM
- 65 I/O pins
- Internal oscillator 8 MHz, 32 KHz
- 2-UART, 2-SPI, 2-I²C, USB 2.0, DAC, ADC etc.

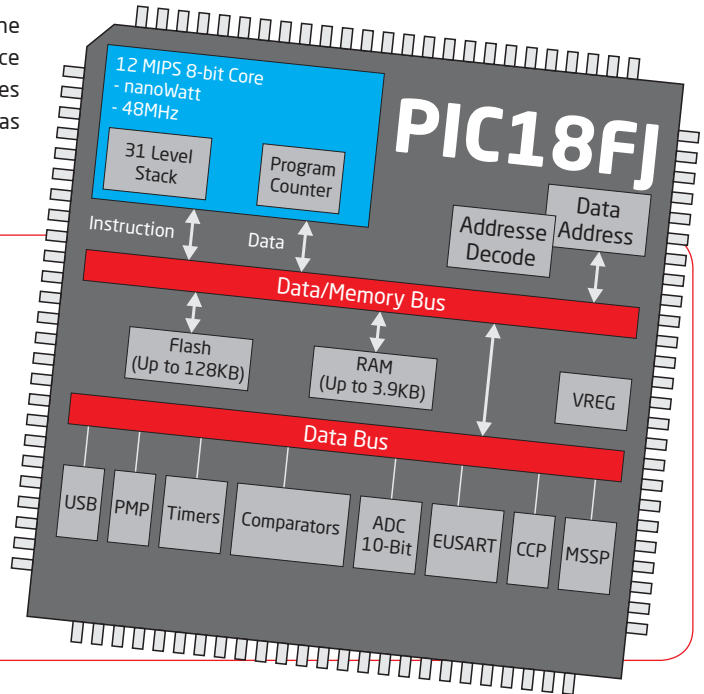

3. Programming the microcontroller

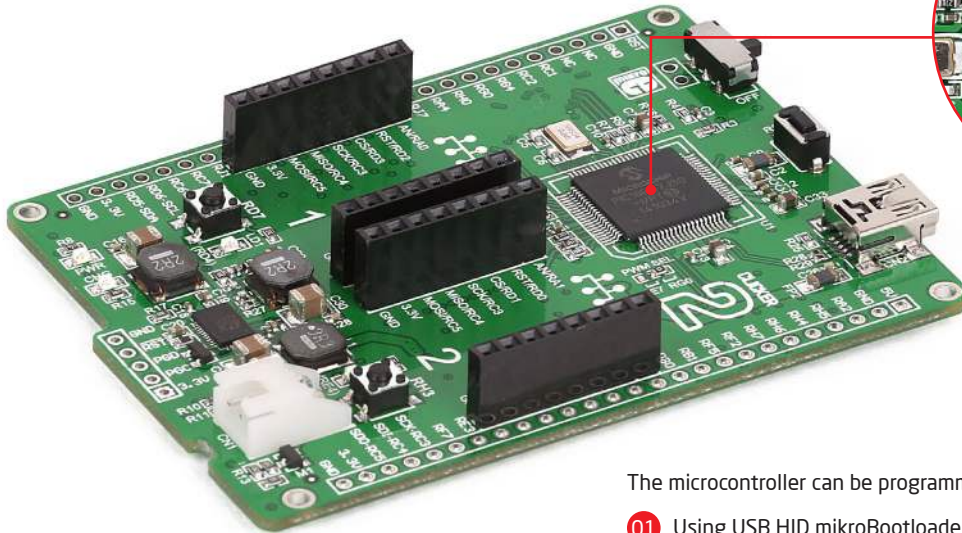

Figure 3-1:
PIC18F87J50
microcontroller

The microcontroller can be programmed in three ways:

- 01 Using USB HID mikroBootloader,
- 02 Using external mikroProg™ for PIC18FJ programmer
- 03 Using external ICD2/3® programmer

3.1 Programming with mikroBootloader

You can program the microcontroller with a bootloader which is preprogrammed by default. To transfer .hex file from a PC to MCU you need bootloader software (**mikroBootloader USB HID**) which can be downloaded from:



http://www.mikroe.com/downloads/get/2156/clicker_2_pic18fj_bootloader.zip

After the mikroBootloader software is downloaded, unzip it to desired location and start it.

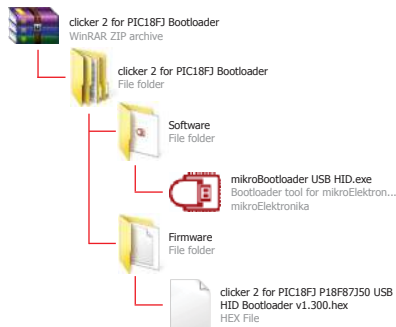

step 1 - Connecting clicker 2 for PIC18FJ



Figure 3-2: USB HID mikroBootloader window

- 01** To start, connect the USB cable, or if already connected press the **Reset** button on your clicker 2 for PIC18FJ. Click the **Connect** button within 5s to enter the bootloader mode, otherwise existing microcontroller program will execute.

step 2 - Browsing for .HEX file



Figure 3-3: Browse for HEX

- 01 Click the **Browse for HEX** button and from a pop-up window (**Figure 3.4**) choose the .HEX file which will be uploaded to MCU memory.

step 3 - Selecting .HEX file

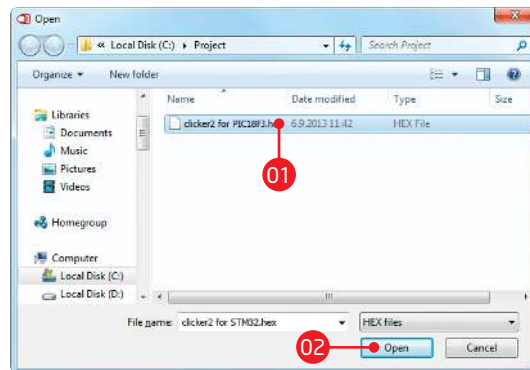

Figure 3-4: Selecting HEX

- 01 Select .HEX file using open dialog window.
- 02 Click the **Open** button.

step 4 - Uploading .HEX file



Figure 3-5: Begin uploading

01 To start .HEX file bootloading click the **Begin uploading** button.



Figure 3-6: Progress bar

01 Progress bar enables you to monitor .HEX file uploading.

step 5 - Finish upload



Figure 3-7: Restarting MCU

- 01 Click **OK** button after the uploading process is finished.
- 02 Press **Reset** button on clicker 2 for PIC18FJ board and wait for 5 seconds. Your program will run automatically.



Figure 3-8: mikroBootloader ready for next job

3.2 Programming with mikroProg™ programmer

The microcontroller can be programmed with external **mikroProg™ for PIC programmer** and **mikroProg Suite™ for PIC® software**. The external programmer is connected to the development system via 1x5 connector **Figure 3-9. mikroProg™** is a fast USB 2.0 programmer with hardware debugger support. It supports PIC10®, dsPIC30/33®, PIC24® and PIC32® devices in a single programmer. It supports over 570 microcontrollers from Microchip®. Outstanding performance, easy operation and elegant design are its key features.

You can also program it with ICD2® or ICD3® if you reroute the wires like shown here.

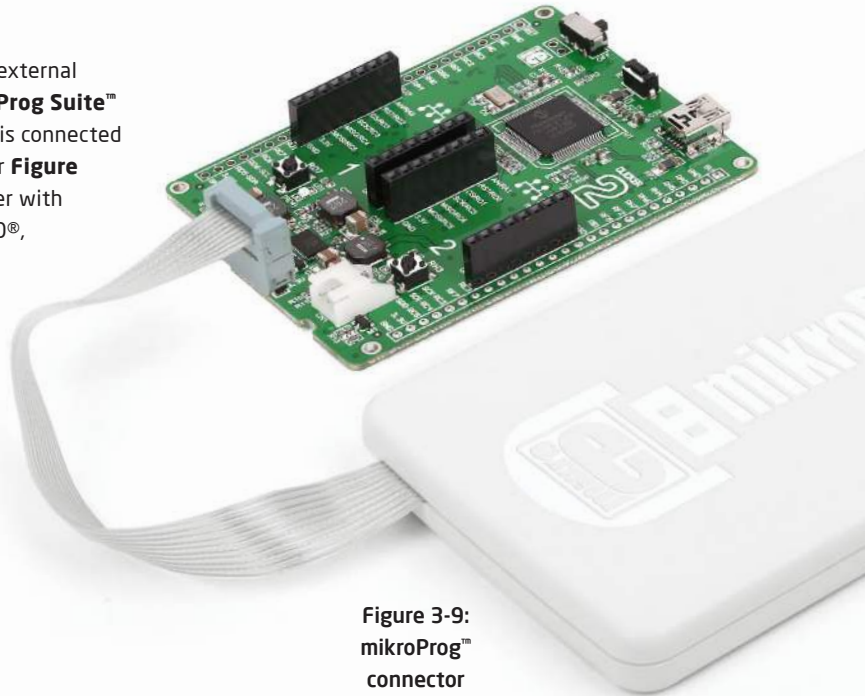
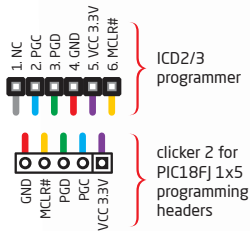
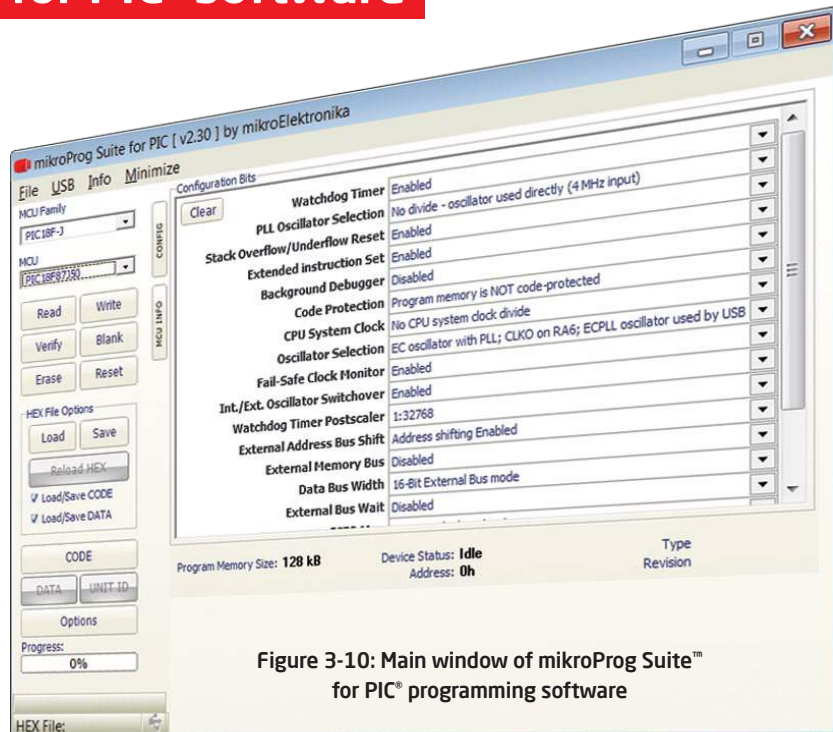

Figure 3-9:
mikroProg™
connector

mikroProg Suite™ for PIC® software



mikroProg™ programmer requires special programming software called **mikroProg Suite™ for PIC®**. This software is used for programming of ALL Microchip® microcontroller families, including PIC10®, PIC12®, PIC16®, PIC18®, dsPIC30/33®, PIC24® and PIC32®. Software has intuitive interface and SingleClick™ programming technology. Just by downloading the latest version of **mikroProg Suite™** your programmer is ready to program new devices. **mikroProg Suite™** is updated regularly, at least four times a year, so your programmer will be more and more powerful with each new release.



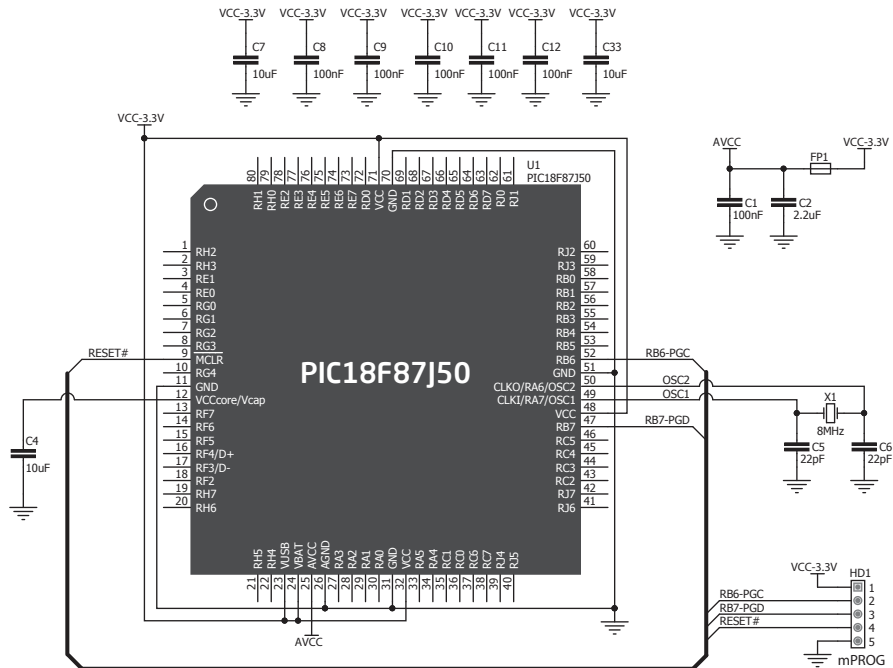

NOTE Before attaching the programming connector, you have to solder the provided 1x5 male header to the programming pads (HD1).

Figure 3-11: mikroProg™ connection schematic

4. Buttons and LEDs

The board also contains a **01 reset button** and a pair of **02 buttons** and **03 LEDs**, as well as an ON/OFF switch. The **Reset button** is used to manually reset the microcontroller—it generates a low voltage level on the microcontroller's reset pin. **LEDs** can be used for visual indication of the logic state on two pins (**RD4** and **RE4**). An active LED indicates that a logic high (1) is present on the pin. Pressing any of the two **buttons** can change the logic state of the microcontroller pins (**RD7** and **RH3**) from logic high (1) to logic low (0). In addition to the onboard ON/OFF switch, two pads (EXT and PSW) allow you to connect your own external switch.

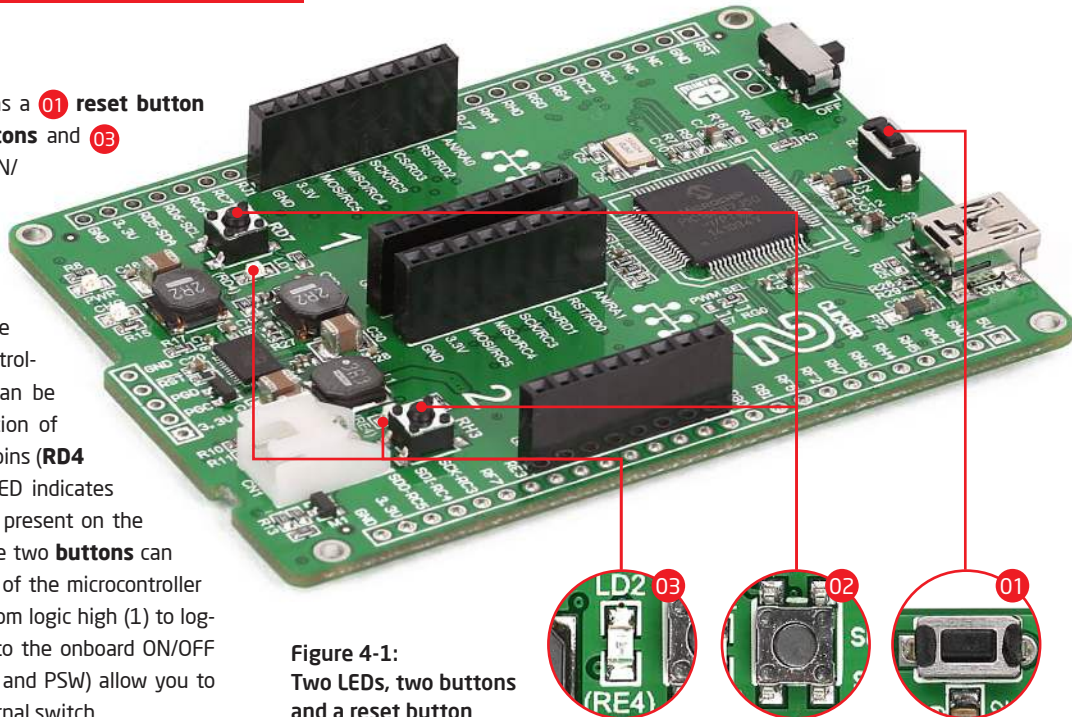

Figure 4-1:
Two LEDs, two buttons
and a reset button

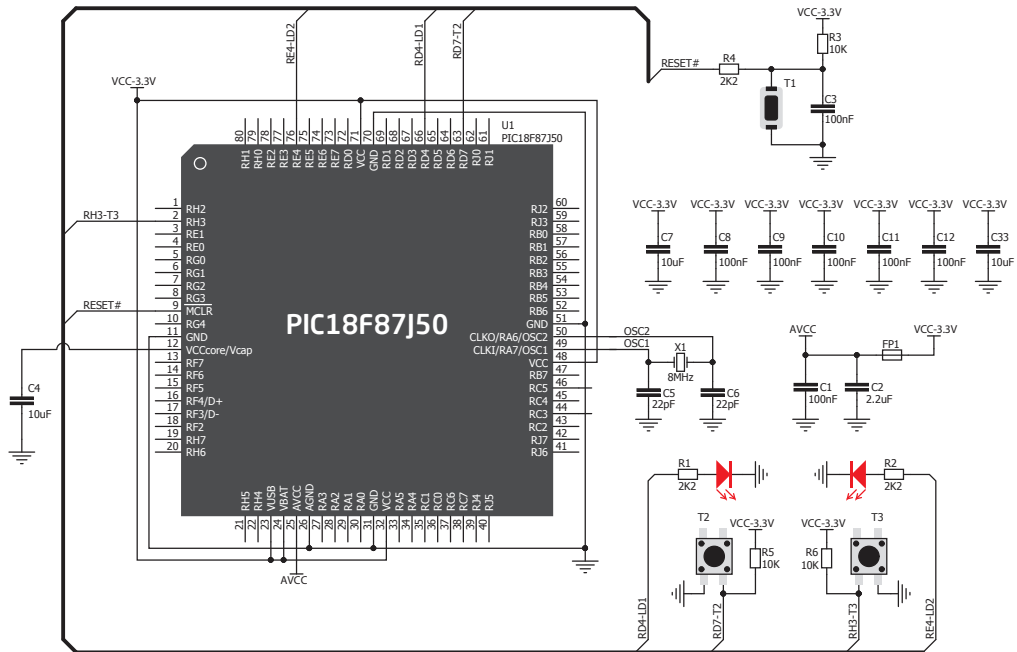

Figure 4-2: Other modules connection schematic

5. Power management and battery charger

clicker 2 for PIC18FJ features **LTC®3586-2**, a highly integrated power management and battery charger IC that includes a current limited switching PowerPath manager. LTC®3586 also **enables battery charging over a USB connection**.

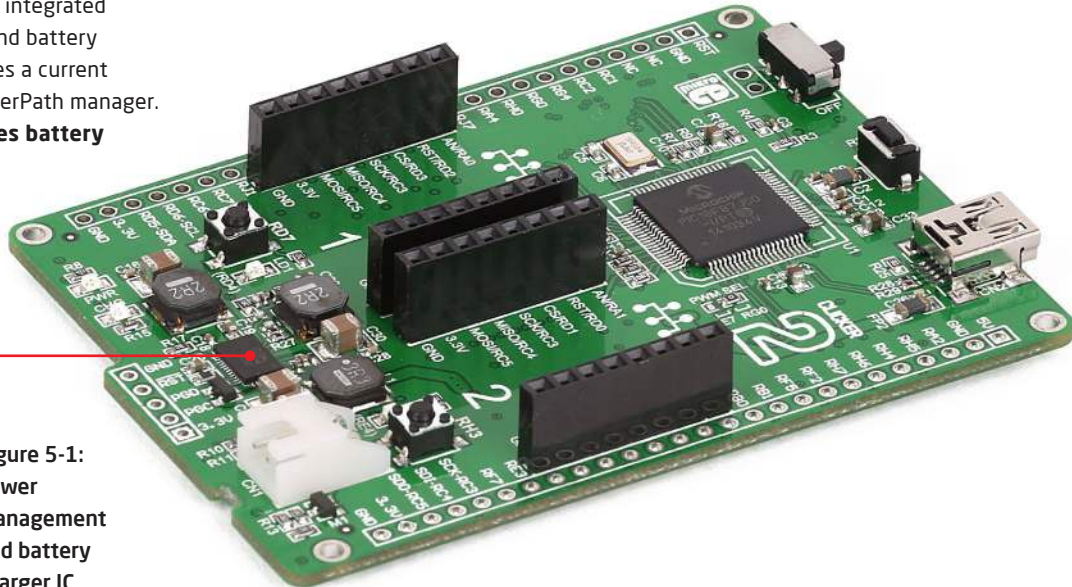

Figure 5-1:
power
management
and battery
charger IC

6. Oscillators

Board is equipped with **8MHz crystal oscillator (X1)** circuit that provides external clock waveform to the microcontroller **CLK0** and **CLKI** pins. This base frequency is suitable for further clock multipliers and ideal for generation of necessary USB clock, which ensures proper operation of bootloader and your custom USB-based applications.

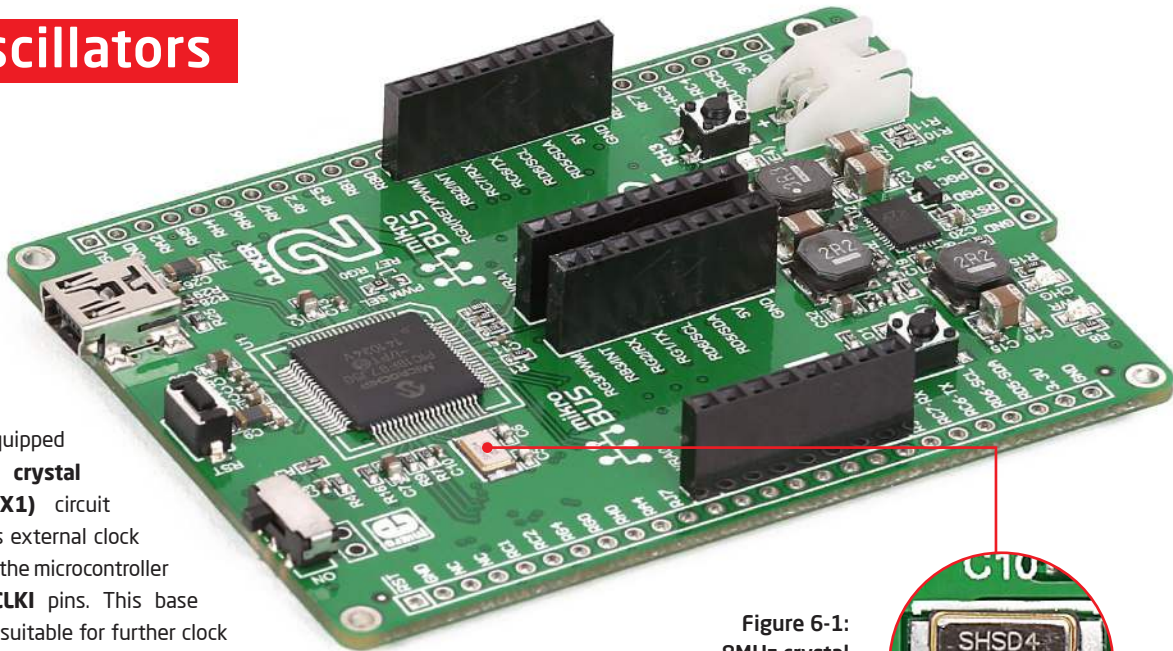

Figure 6-1:
8MHz crystal
oscillator
module (X1)



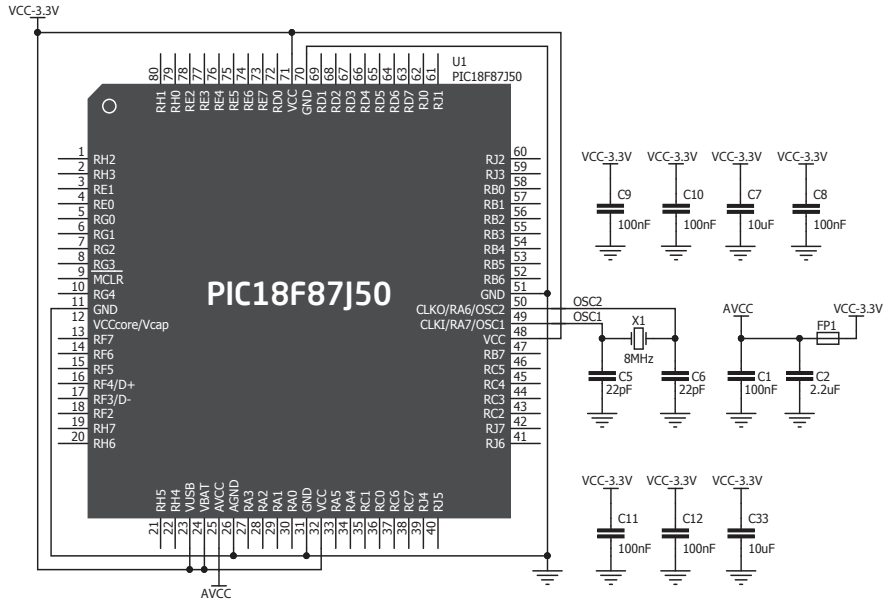

Figure 6-2:
Crystal
oscillator
schematic

NOTE | *The use of crystal in all other schematics is implied even if it is purposely left out, because of the schematics clarity.*

7. USB connection

PIC18F87J50 microcontrollers has an integrated USB module, which enables you to implement USB communication functionality to your clicker 2 board. Connection with target USB host is done over a Mini-B USB connector which is positioned next to the battery connector.

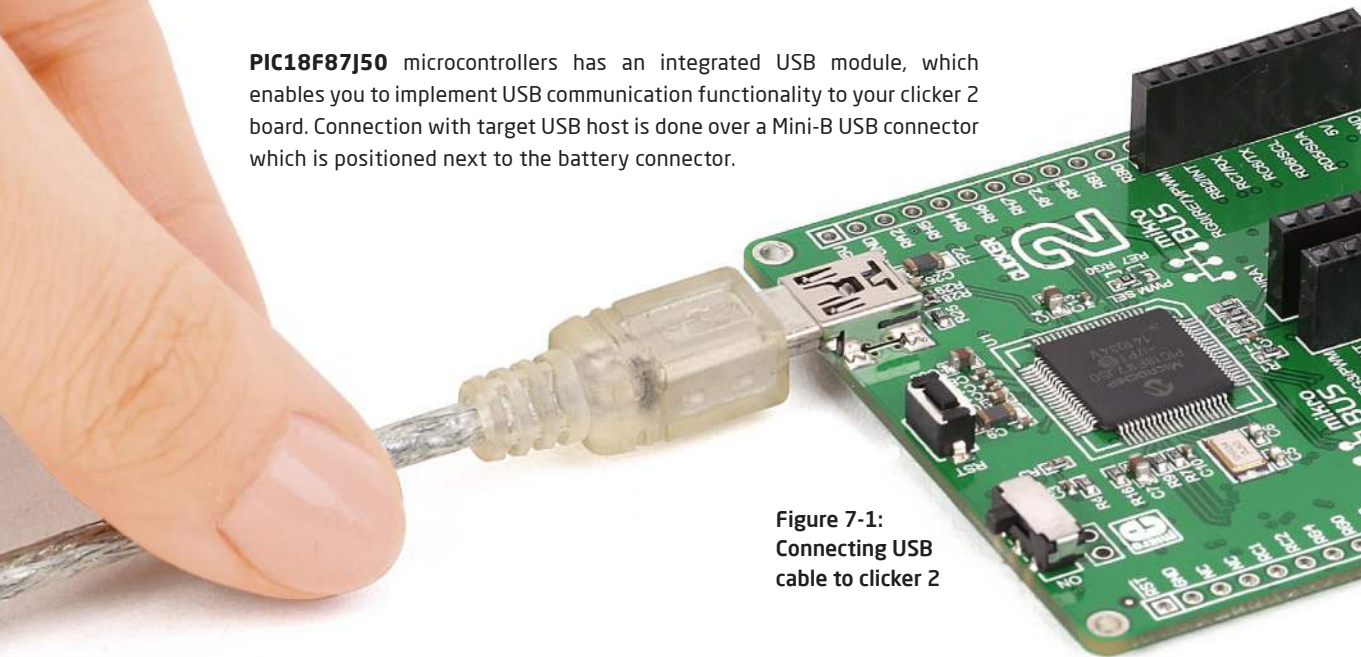

Figure 7-1:
Connecting USB
cable to clicker 2

8. Pads



Pads HDR2

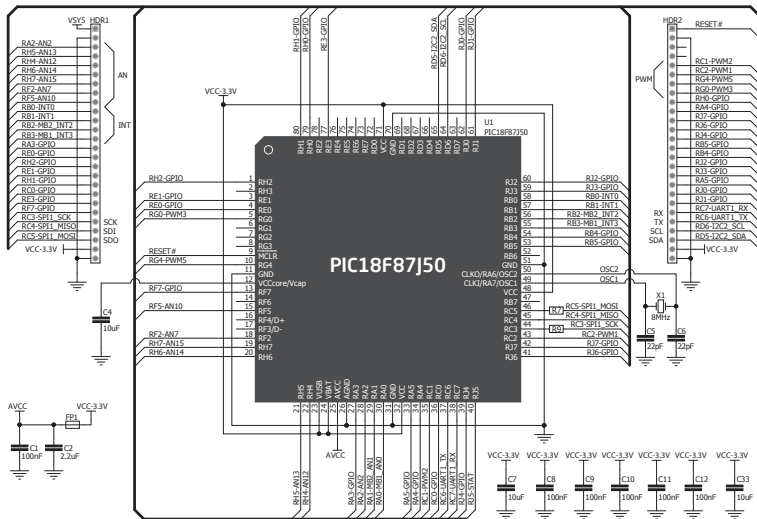

Figure 8-1: Connecting pads schematic

Pads HDR1



Most microcontroller pins are available for further connectivity via two 1x26 rows of connection pads on both sides of the clicker 2 for PIC18FJ board. They are designed to match additional shields, such as Battery Boost shield, Gaming, PROTO shield and others.

9. Pinout

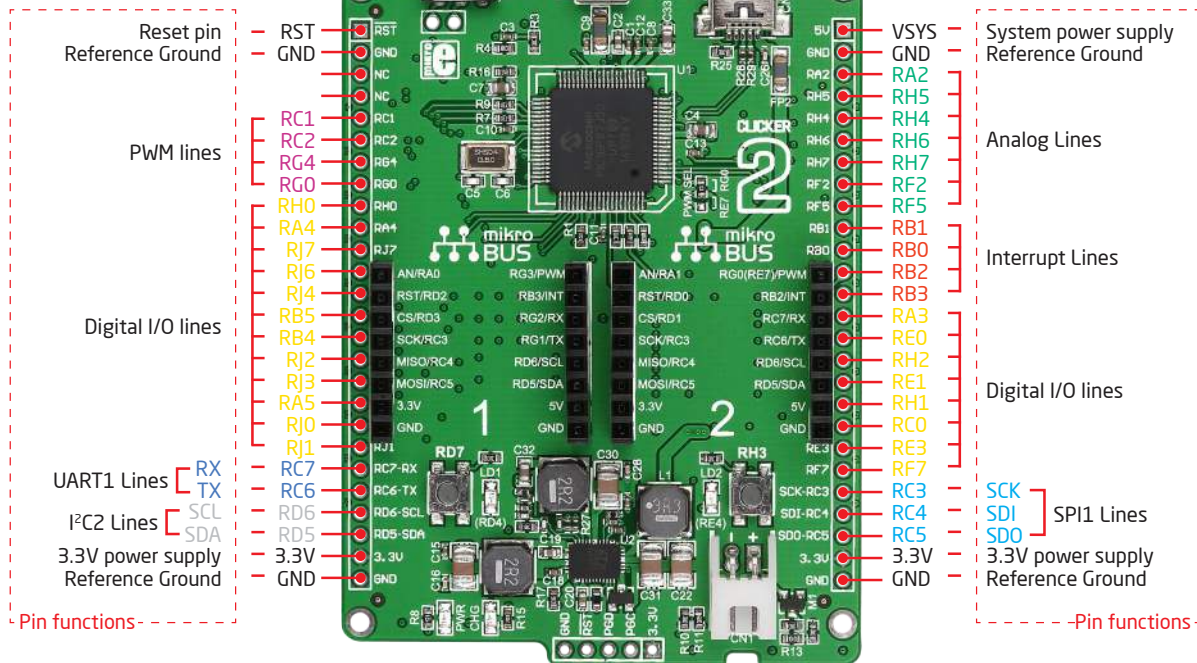

9.1 mikroBUS™ pinouts

clicker 2 for PIC18FJ employs a solution to optimize the use of available pins and MCU I/Os. The **PWM SEL jumper** (Figure 9-2) enables **two modes** of use for the second available PWM line:

1 The default position of the jumper is for applications when you're not using the PWM line on the 1x26 pinout on the right side of the board. This keeps this PWM available through mikroBUS™ 2

2 If you resolder the jumper into the second position, it would turn the PWM line on mikroBUS™ 2 into a GPIO. You would use this in scenarios where you already utilized the PWM through the 1x26 pinout (which would make the PWM pin on mikroBUS™ 2 unusable)

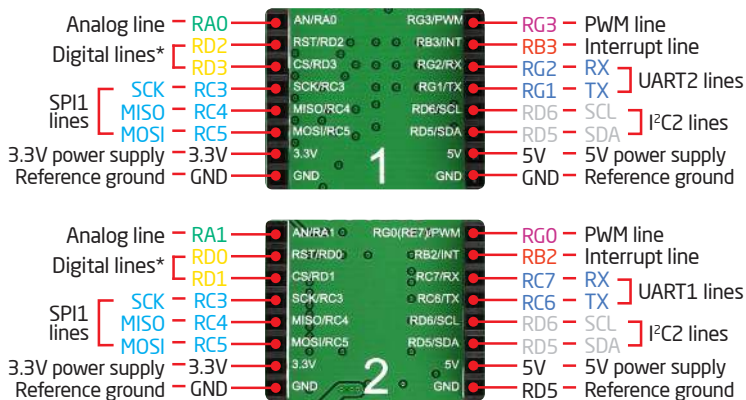

Figure 9-1: mikroBUS™ individual and shared lines

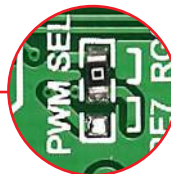
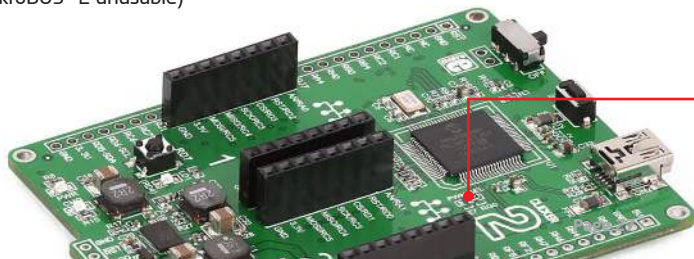

Figure 9-2:
PWM SEL jumper

10. click boards™ are plug and play!

Up to now, MikroElektronika has released more than 90 mikroBUS™ compatible **click boards™**. On the average, one click board is released per week. It is our intention to provide you with as many add-on boards as possible, so you will be able to expand your development board with additional functionality. Each board comes with a set of working example code. Please visit the click boards™ webpage for the complete list of currently available boards:



www.mikroe.com/click



Figure 10-1:
clicker 2 for PIC18FJ
driving click boards™



RFid click



Relay click



8x8 click



FM click



Bluetooth2 click



Thunder click



USB SPI click



BarGraph click



7seg click



THERMO click

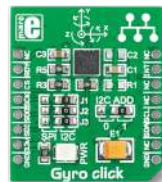

Gyro click

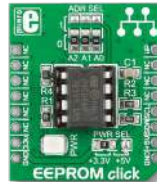

EEPROM click



LightHz click



Pressure click

11. Dimensions

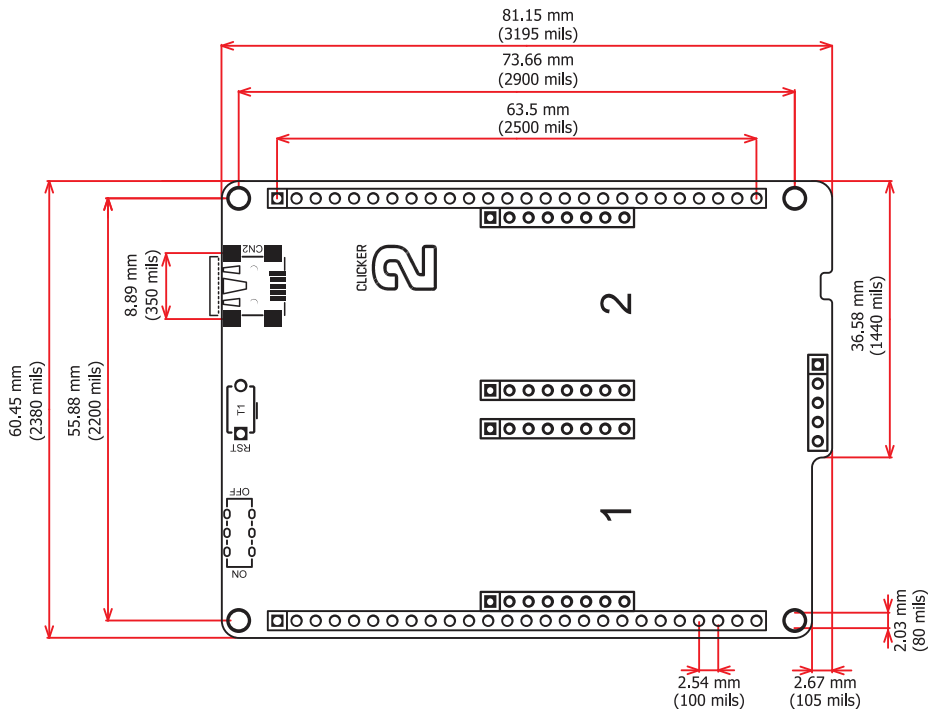

DISCLAIMER

All the products owned by MikroElektronika are protected by copyright law and international copyright treaty. Therefore, this manual is to be treated as any other copyright material. No part of this manual, including product and software described herein, may be reproduced, stored in a retrieval system, translated or transmitted in any form or by any means, without the prior written permission of MikroElektronika. The manual PDF edition can be printed for private or local use, but not for distribution. Any modification of this manual is prohibited.

MikroElektronika provides this manual 'as is' without warranty of any kind, either expressed or implied, including, but not limited to, the implied warranties or conditions of merchantability or fitness for a particular purpose.

MikroElektronika shall assume no responsibility or liability for any errors, omissions and inaccuracies that may appear in this manual. In no event shall MikroElektronika, its directors, officers, employees or distributors be liable for any indirect, specific, incidental or consequential damages (including damages for loss of business profits and business information, business interruption or any other pecuniary loss) arising out of the use of this manual or product, even if MikroElektronika has been advised of the possibility of such damages. MikroElektronika reserves the right to change information contained in this manual at any time without prior notice, if necessary.

HIGH RISK ACTIVITIES

The products of MikroElektronika are not fault - tolerant nor designed, manufactured or intended for use or resale as on - line control equipment in hazardous environments requiring fail - safe performance, such as in the operation of nuclear facilities, aircraft navigation or communication systems, air traffic control, direct life support machines or weapons systems in which the failure of Software could lead directly to death, personal injury or severe physical or environmental damage ('High Risk Activities'). MikroElektronika and its suppliers specifically disclaim any expressed or implied warranty of fitness for High Risk Activities.

TRADEMARKS

The MikroElektronika name and logo, mikroC™, mikroBasic™, mikroPascal™, Visual TFT™, Visual GLCD™, mikroProg™, Ready™, MINI™, mikroBUS™, EasyPIC™, EasyAVR™, Easy8051™, clickboards™ and mikromedia™ are trademarks of MikroElektronika. All other trademarks mentioned herein are property of their respective companies. All other product and corporate names appearing in this manual may or may not be registered trademarks or copyrights of their respective companies, and are only used for identification or explanation and to the owners' benefit, with no intent to infringe.

Copyright © 2014 MikroElektronika. All Rights Reserved.



If you want to learn more about our products, please visit our web site at www.mikroe.com

If you are experiencing some problems with any of our products or just need additional information, please place your ticket at www.mikroe.com/support

If you have any questions, comments or business proposals,
do not hesitate to contact us at office@mikroe.com