

DRV10983-Q1 Evaluation Module

This user's guide provides complete details of the customer evaluation module (EVM) for the DRV10983-Q1 device including hardware implementation, jumper configuration, and operating procedure to run 3-phase BLDC motors. This EVM user's guide is intended to be used with the [DRV10983-Q1 Tuning Guide](#) to optimally tune a user motor.

Contents

1	DRV10983-Q1 EVM Kit Contents	3
2	Introduction	3
3	DRV10983-Q1 EVM Board	4
	3.1 Power and Motor Connectors P1	4
	3.2 Test Point Connector P2.....	4
	3.3 Control Input Connectors J3.....	4
	3.4 Jumper J1 (Direction)	5
	3.5 Jumper J2 (Speed Input)	5
	3.6 FG Test Pin.....	5
4	DRV10983-Q1 GUI	6
	4.1 Overview	6
	4.2 Basic Settings	6
5	Out-of-the-Box Quick-Start Guide.....	10
6	Power-On Sequence and Connection With User Specific Motor	15
7	Schematic and Bill of Materials.....	15
	7.1 Schematic	15
	7.2 Bill of Materials (BOM).....	17
Appendix A	GUI Installation and Overview	18
Appendix B	GUI to DRV10983-Q1 Register Cross Reference	35

List of Figures

1	DRV10983-Q1 EVM.....	3
2	DRV10983-Q1 GUI Basic Settings.....	6
3	Example Dropdown Menu	7
4	Example Checkbox.....	7
5	Example Text Box	7
6	DRV10983-Q1 GUI Advanced Settings.....	8
7	DRV10983-Q1 GUI Display Settings.....	9
8	Initial GUI Screen	11
9	Initial GUI Screen	11
10	GUI in Demo Mode	12
11	Enable Configure.....	13
12	Fault Code Information	13
13	Disabled Motor Operation Selected	14
14	OverRide Selected	15
15	DRV10983-Q1 Schematic.....	16
16	Setup_DRV109xx_EVM.exe from the Volume Folder.....	18
17	GUI Installation Initialization	19

18	License Agreement	19
19	GUI Destination Directory	20
20	GUI Start Installation.....	20
21	GUI Installation in Progress.....	21
22	Python Installation Complete	21
23	USB2ANY Installation Initialization	22
24	USB2ANY License Agreement	22
25	USB2ANY Destination Directory	23
26	USB2ANY Start Installation	23
27	USB2ANY Installation Complete	24
28	Basic Settings Page	25
29	Confirmation on Voltage Level	26
30	Help Icon	27
31	Advanced Settings	27
32	Display	28
33	About Page.....	29
34	File Menu.....	30
35	Script Menu	30
36	Launch Macro.....	31
37	Start Recording	32
38	Stop Recording	32
39	Run Macro	33
40	Debug Menu	34

List of Tables

1	P1 Terminal Assignments	4
2	P2 Terminal Assignments	4
3	J3 Terminal Assignments.....	4
4	DIR PIN Setting	5
5	SPEED Pin Setting	5
6	DRV10983-Q1 Bill of Materials	17
7	GUI to DRV10983-Q1 Register Cross Reference	35

Trademarks

Microsoft, Windows are registered trademarks of Microsoft Corporation.
All other trademarks are the property of their respective owners.

1 DRV10983-Q1 EVM Kit Contents

The DRV10983-Q1 evaluation kit contains the following:

- DRV10983-Q1 EVM board
- USB2ANY communication board for I²C GUI interaction
- USB cable
- 10-pin ribbon cable to connect the USB2ANY and DRV10983-Q1 EVM
- DRV10983-Q1 EVM GUI

The DRV10983-Q1 EVM boards and GUI are designed to work together to evaluate the device features.

2 Introduction

The DRV10983-Q1 EVM is a complete solution for evaluating the DRV10983-Q1, three-phase sensorless BLDC motor drivers. Device evaluation and configuration for specific applications is possible with the provided DRV10983-Q1 EVM GUI. This document describes the kit details and explains the functions and locations of test points, jumpers, and connectors present on the kit. This document is also a quick-start guide for using the GUI to tune a motor for application. For detailed information about the operating modes of the DRV10983-Q1 device, refer to the [DRV10983-Q1 Automotive, Three-Phase, Sensorless BLDC Motor Driver data sheet](#).

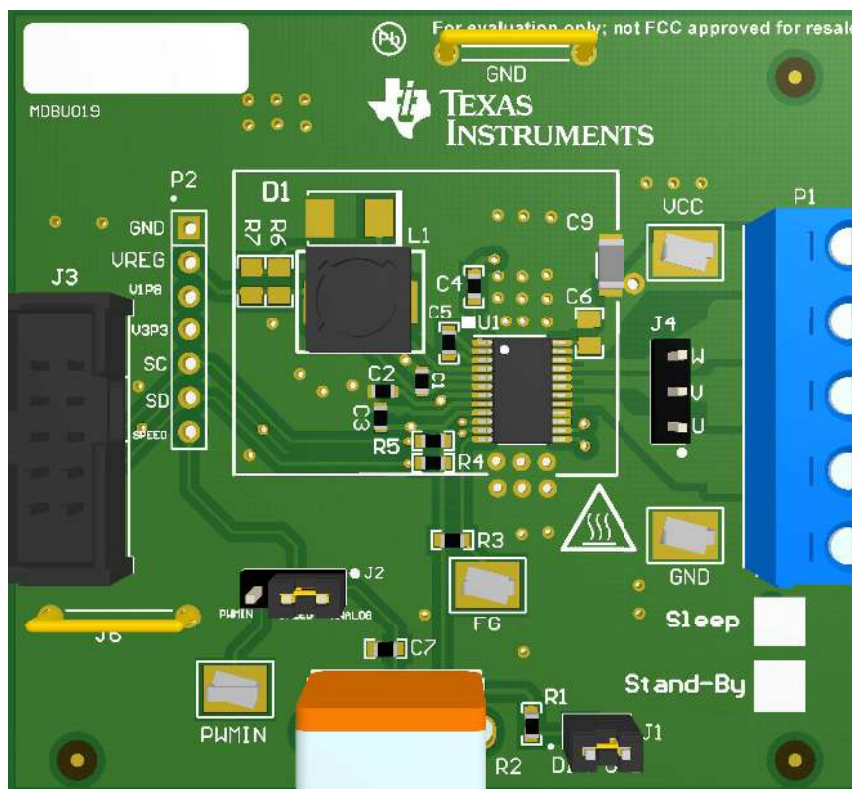

Figure 1. DRV10983-Q1 EVM

3 DRV10983-Q1 EVM Board

3.1 Power and Motor Connectors P1

The DRV10983-Q1 EVM shares terminal P1 for power supply and motor-phase output. Use a single power-supply rail between 6.2 V to 28 V to operate the EVM. [Table 1](#) lists the pin assignment of terminal P1.

Table 1. P1 Terminal Assignments

Pin	Description
1	VCC
2	W
3	V
4	U
5	GND

3.2 Test Point Connector P2

The P2 connector can be used to measure signals from the DRV10983-Q1 device. P2 is not populated. [Table 2](#) lists the pin assignment of terminal P2.

Table 2. P2 Terminal Assignments

Pin	Description
1	GND
2	VREG
3	V1P8
4	V3P3
5	SC from J3 (connects to SCL of device)
6	SD from J3 (connects to SDA of device)
7	SPEED input from PWDIN or ANALOG (R2)

3.3 Control Input Connectors J3

The J3 connector is used for the I²C interconnection with the GUI. [Table 3](#) lists the pin assignment of terminal J3.

Table 3. J3 Terminal Assignments

Pin	Description
6	GND
9	SD (connects to SDA of device)
10	SC (connects to SCL of device)

3.4 Jumper J1 (Direction)

To control the spin direction of the motor, the DRV10983-Q1 EVM is equipped with a direction jumper. Depending if 3V3 or GND is supplied to the DRV10983-Q1 direction input, the motor spins either in forward or reverse direction.

Table 4. DIR PIN Setting

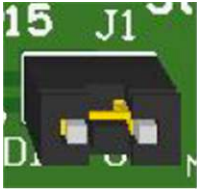
J1 Connection	Description	
	Unconnected	DIR is set to 3.3 V
	Connected	DIR is set to GND (shown)

3.5 Jumper J2 (Speed Input)

The motor speed input source is configured with J2. If J2 pins 2-3 is populated, supply a PWM to the PWMIN test pin to control the motor speed. If J2 pins 1-2 is populated, the motor speed is controlled with the analog potentiometer R2 equipped on the EVM.

Table 5. SPEED Pin Setting

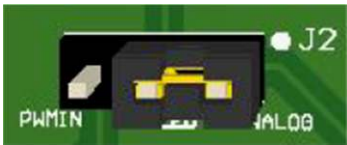
J2 Connection	Description	
	1-2	Analog potentiometer R2 (shown)
	2-3	PWMIN digital input

NOTE: The motor operation can be unpredictable if the internal register setting the DRV10983-Q1 device does not match the J2 selection.

3.6 FG Test Pin

The frequency generator (FG) test pin outputs the motor speed, depending on the internal DRV10983-Q1 divider setting and the number of motor poles.

4 DRV10983-Q1 GUI

4.1 Overview

The DRV10983-Q1 EVM is provided with a GUI to configure the device and tune the application. See [Appendix A](#) for instructions to download and install the [GUI application](#). The GUI is structured into three tabs (*Basic Settings*, *Advanced Settings*, and *Display*) allowing configuration of the register settings and tuning of the device parameters for the target application. For details about the settings, refer to the [DRV10983-Q1 Automotive, Three-Phase, Sensorless BLDC Motor Driver data sheet](#).

The following sections include DRV10983-Q1 GUI images to explain the various features of the GUI.

4.2 Basic Settings

The *Basic Settings* tab is the landing screen after launching the GUI on the computer. The tab sets the motor parameters, startup parameters, initial speed detection prior to startup, and current limits. This tab can also load and save motor parameters and program the EEPROM with optimized settings.

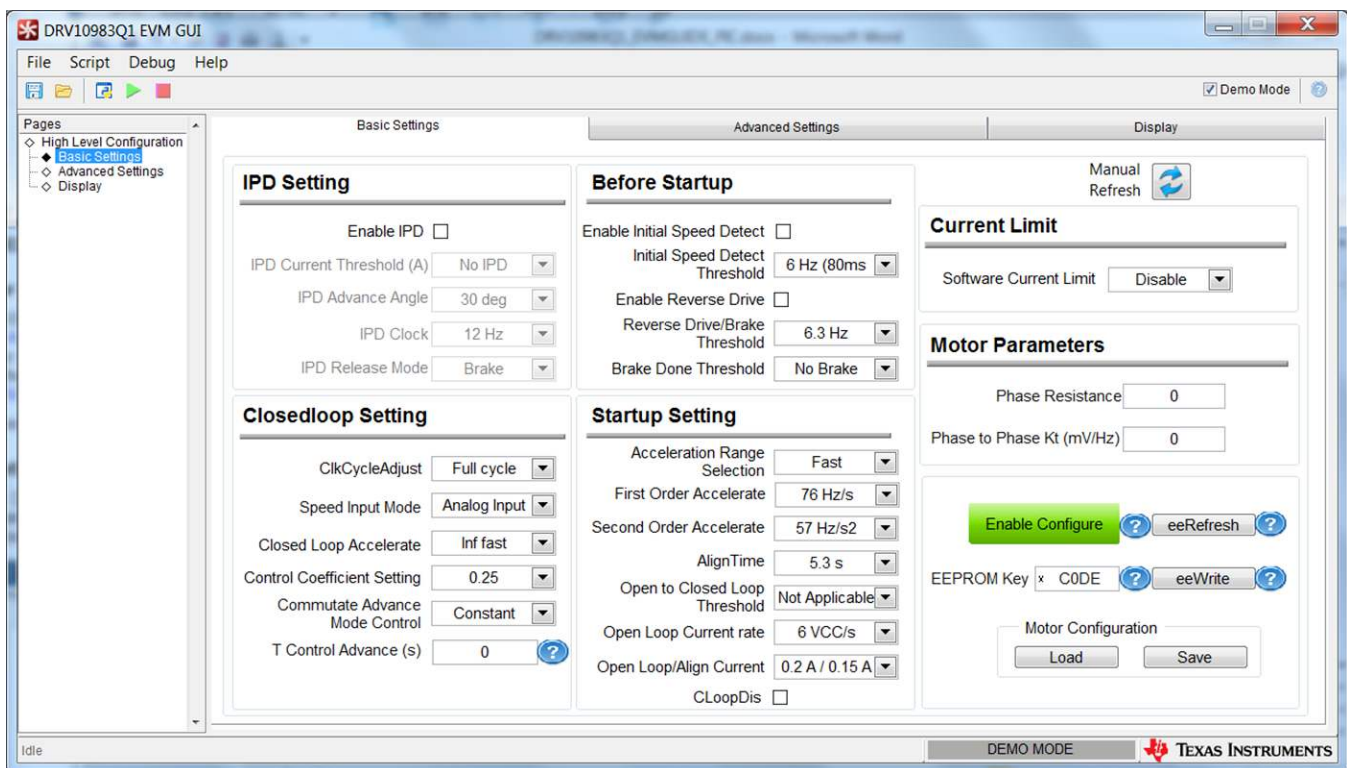

Figure 2. DRV10983-Q1 GUI Basic Settings

4.2.1 Communication

The GUI is designed to work with and without the hardware connected, allowing evaluation of the available settings. Click the *Demo Mode* checkbox in the top right to work offline when the box is checked. When the EVM is connected to the GUI, this box should be unchecked and the status bar in the bottom right displays *Connected*. If the GUI cannot connect to the hardware, check that the hardware is powered and the I²C communication is correctly established.

4.2.2 Register Access – Enable Configure

To access the register settings, click the *Enable Configure* button (see [Figure 2](#)). When selected, the button changes from the default gray to green, and the settings can be changed.

4.2.3 Changing Register Settings

The GUI supports three different input types to set the register values which are defined as follows:

Dropdown menu — This menu provides a list to select a predefined setting as shown in [Figure 3](#).

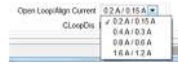

Figure 3. Example Dropdown Menu

Checkbox — Select this checkbox to set single bit values. [Figure 4](#) shows the checkbox enabled.

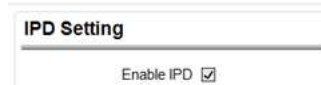

Figure 4. Example Checkbox

Text box — The text box allows users to input data that might be changed by the device because of the data type conversions. In [Figure 5](#), a value of 1.5 was entered and the nearest value, 1.552, was selected.

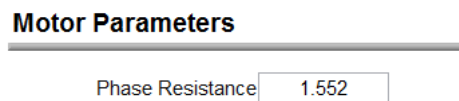

Figure 5. Example Text Box

4.2.4 Work With EEPROM

The settings are saved and loaded using the *Save* and *Load* buttons on the *Basic Settings* tab. When saved, the file is written as a .csv file that can be loaded at a later time.

To program the DRV10983-Q1 devices and change the default EEPROM settings, follow the instructions listed in the [DRV10983-Q1 Automotive, Three-Phase, Sensorless BLDC Motor Driver data sheet](#).

4.2.4.1 Advanced Settings

The *Advance Settings* tab controls functions such as lock detection, anti-voltage surge (AVS), dead time, PWM frequency, Current Limit for Lock Detection, slew rate, Duty Cycle Limit, spread-spectrum modulation, and Temp Warning Action.

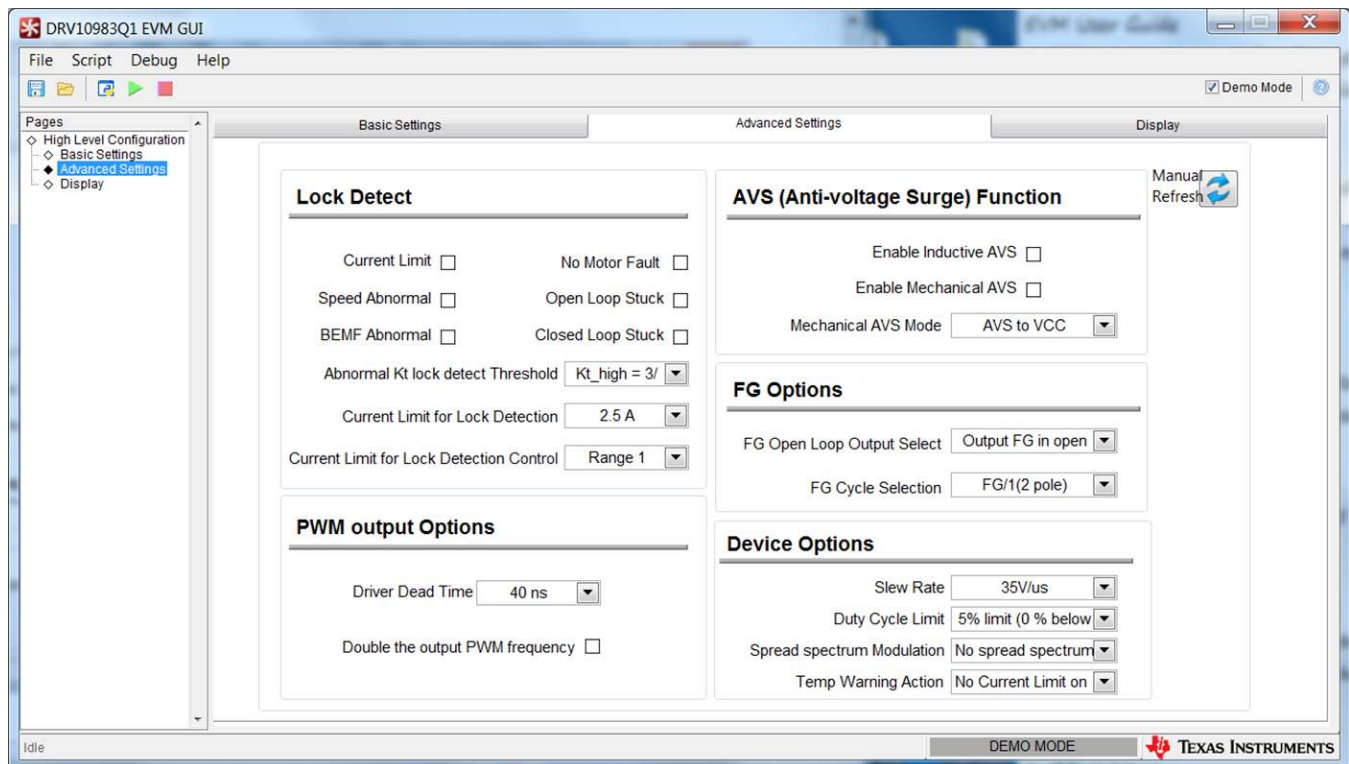

Figure 6. DRV10983-Q1 GUI Advanced Settings

4.2.4.2 Display

The *Display* tab monitors the device status and motor parameters.

The left section of the *Display* tab (also called *Display*) shows all motor parameters. The parameters can be refreshed manually, or automatically every second.

NOTE: Auto refresh may slow communication with the device.

The right section of the *Display* tab shows the device status. An active fault condition lights the red indication.

Control the motor speed from the GUI with the speed control options in the bottom section of the *Display* tab. To control the motor speed using the GUI, check the OverRide bit and set the motor speed from 0 to 511 decimal. To disable Motor Operation, check the Disable Motor Operation bit.

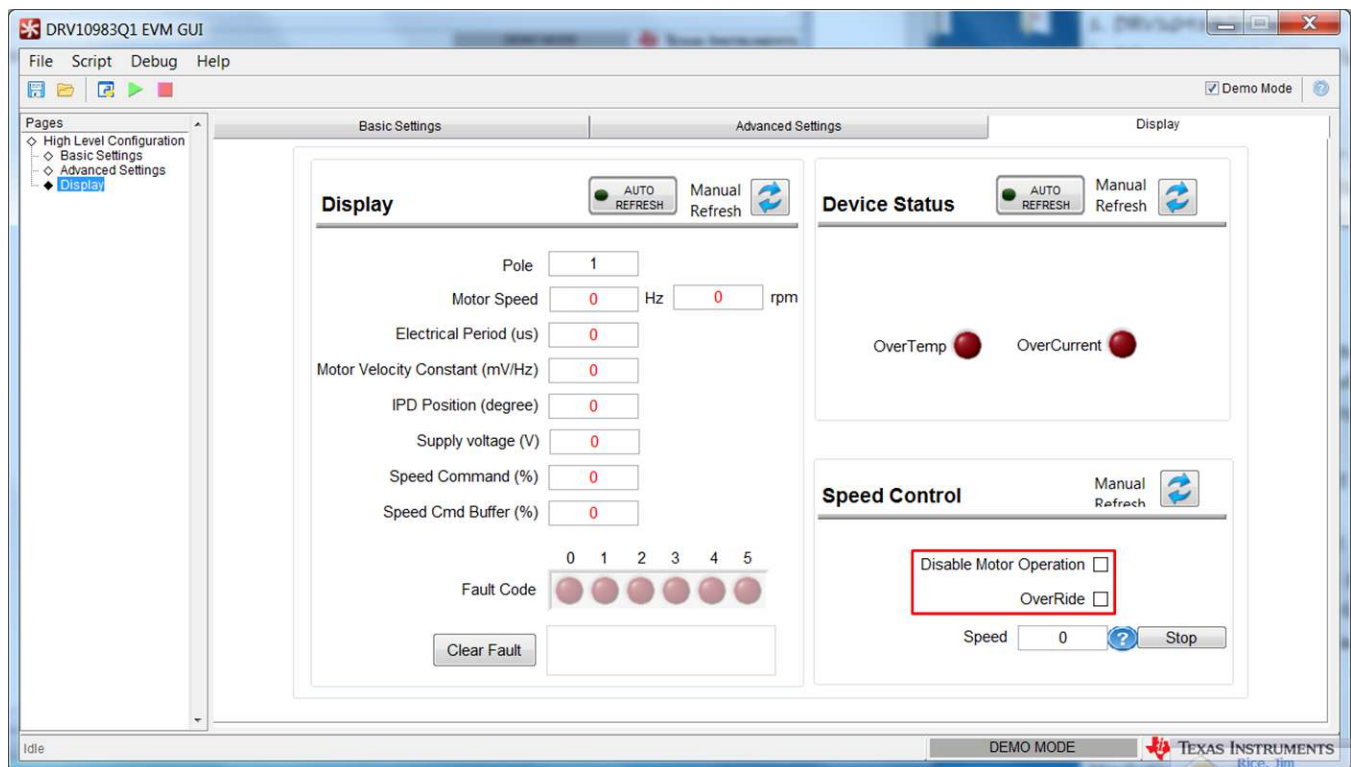

Figure 7. DRV10983-Q1 GUI Display Settings

5 Out-of-the-Box Quick-Start Guide

This section assumes that the user has already downloaded the DRV10983-Q1 application GUI as mentioned in [Appendix A](#).

Perform the following procedure to confirm proper operation of the EVM kit:

- Step 1. Do not connect the motor phases and ensure that jumper J2 is set to *Analog*.
- Step 2. Set the speed input to 0 by rotating the potentiometer R2 fully counterclockwise. If the DRV10983Q Sleep mode device replaces the device in the EVM, set the speed input to maximum by rotating the potentiometer R2 fully clockwise, and skip [step 3](#).
- Step 3. Connect the motor phases of the user motor to connector P1. Phase sequence is not important as it only determines the direction of rotation.
- Step 4. Connect the USB2ANY board to the computer using the supplied USB cable.
- Step 5. Connect the 10-pin ribbon cable header to J4 on the USB2ANY board and J3 on the DRV10983-Q1 EVMs.
- Step 6. Connect a power supply to VCC (pin1) and GND (pin 5) of connector P1.



WARNING

Caution Hot surface. Contact may cause burns. Do not touch.

- Step 7. Power on the EVM VCC by applying 12 V.

CAUTION

With VCC, never exceed 45 V on the DRV10983-Q1 EVMs during motor operation.

- Step 8. Launch the DRV109XXEVM.exe application on the computer (see [Appendix A](#)).
- Step 9. Select the appropriate device configuration as shown in [Figure 8](#).
- Step 10. Click the *OK* button.

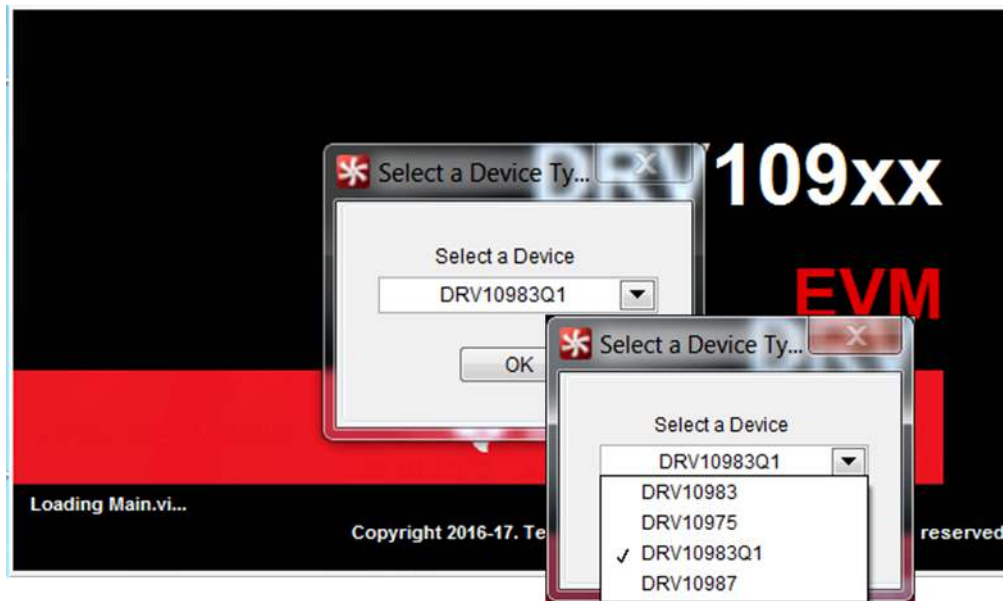

Figure 8. Initial GUI Screen

- If no hardware is connected, or if a hardware connection problem occurs, the GUI displays the error message as shown in Figure 9. Confirm the hardware connection. Retry the initialization or click the *Demo Mode* button to operate in demo mode.

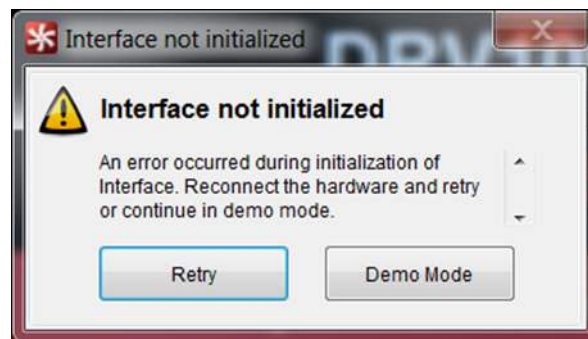

Figure 9. Initial GUI Screen

- If the *Demo Mode* button was clicked, the GUI displays the *Basic Settings* as shown in Figure 10. Click the *Demo Mode* checkbox to deselect the demo mode communication and proceed to step 11.
- If the *Retry* button was selected, the GUI displays the screen as shown in Figure 11 directly after step 10.

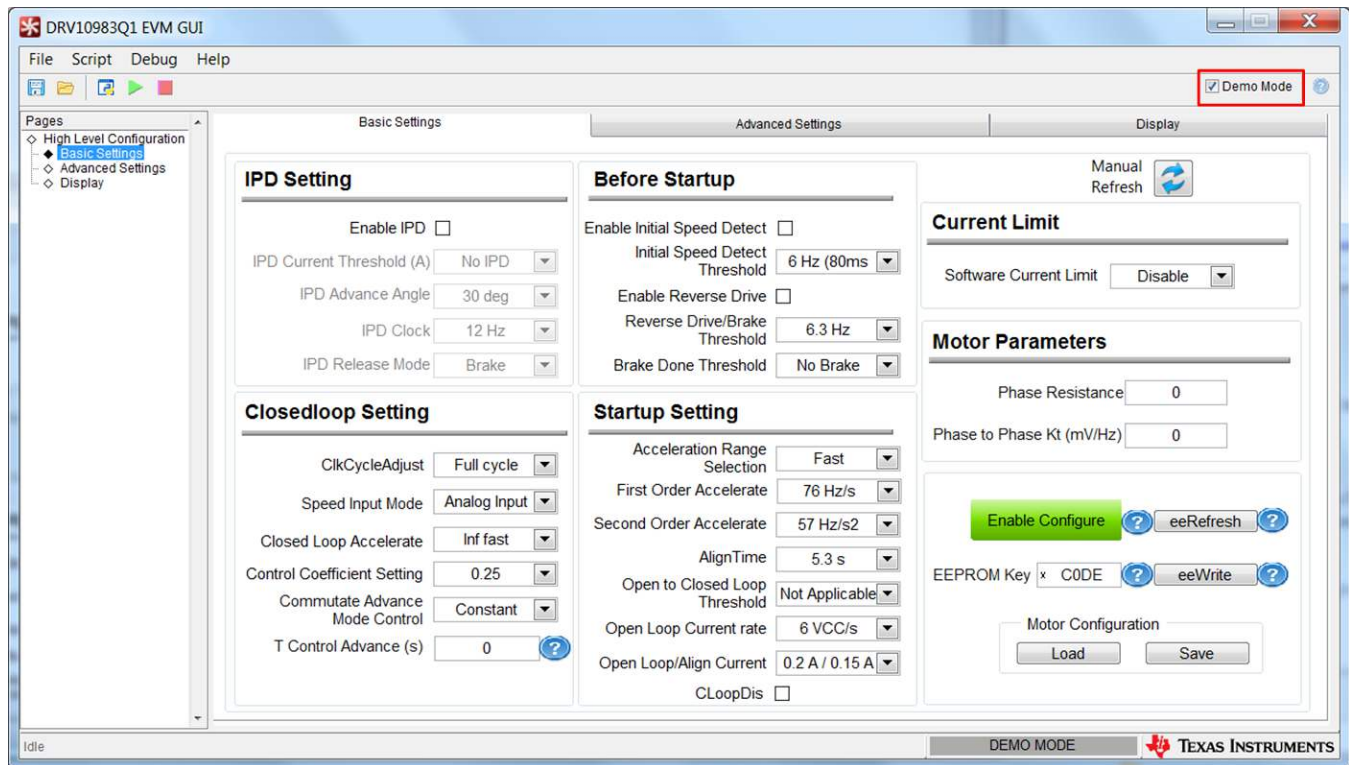

Figure 10. GUI in Demo Mode

Step 11. The status bar displays *HARDWARE CONNECTED* and the bar turns green, indicating that the GUI is communicating with the device. Click the *Enable Configure* to change this button from the red to green (see [Figure 11](#)).

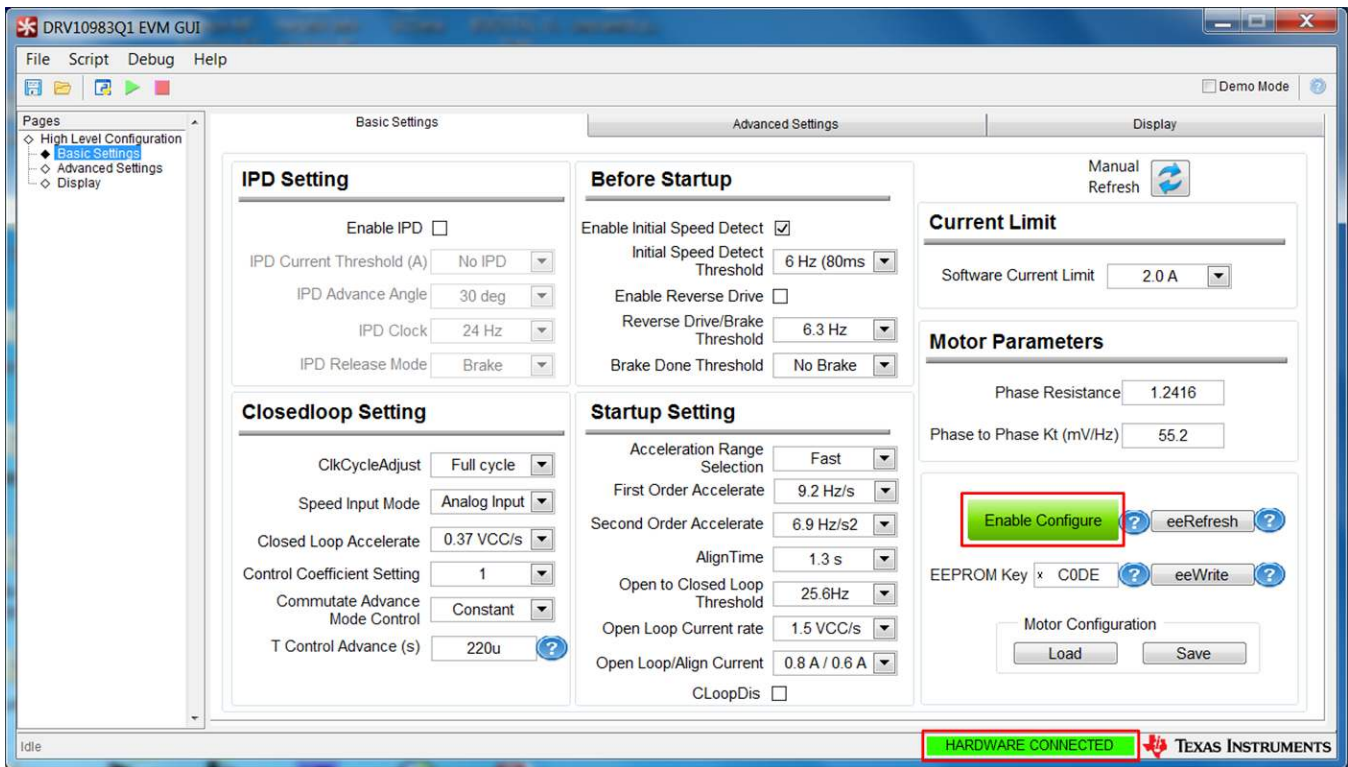

Figure 11. Enable Configure

Step 12. The *Display* tab provides fault code information.

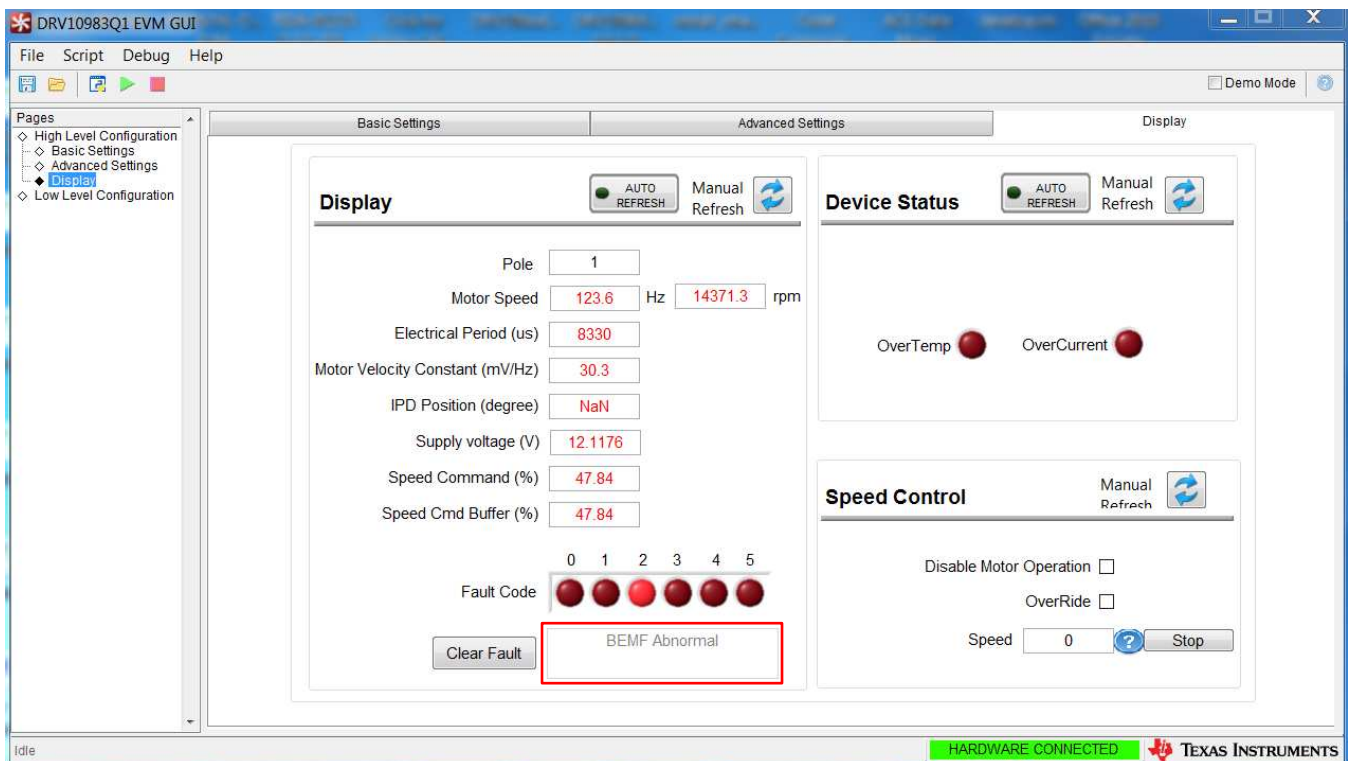

Figure 12. Fault Code Information

In PWM input mode, the motor speed increase as increasing PWM duty cycle, and the motor speed decrease as decreasing PWM duty cycle. In analog input mode, the motor speed increases as the potentiometer R2 is turned clockwise, and decreases as R2 is turned counter clockwise. Check the Disable Motor Operation bit, load, or change desired parameter information, then uncheck the Disable Motor Operation bit. If the DRV10983Q Sleep mode device replaces the device in the EVM, connect the motor phases of the user motor to the P1 connector before unchecking the Disable Motor Operation bit.

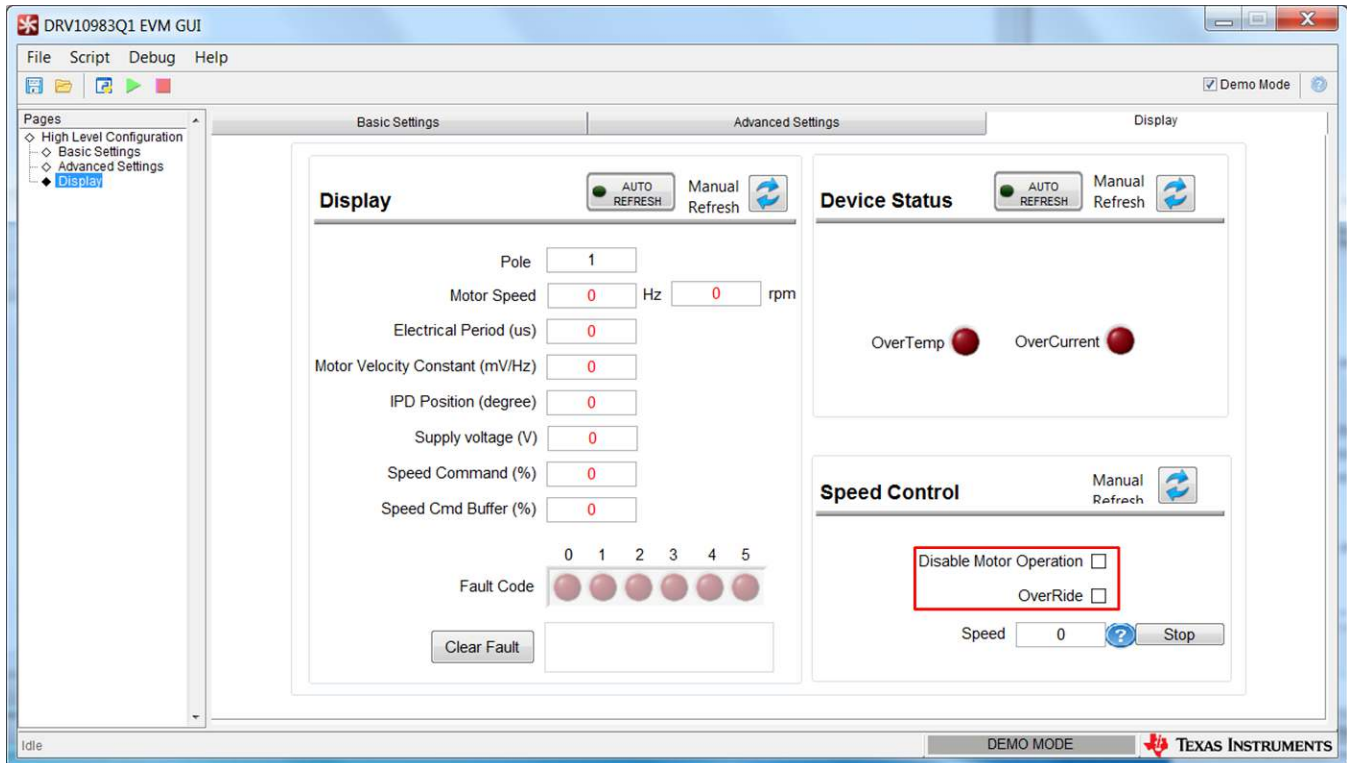

Figure 13. Disabled Motor Operation Selected

- Step 13. Change the motor direction by connecting or removing jumper J1.
- Step 14. Switch to the *Display* tab and select the *OverRide* checkbox to override the PWM or analog voltage speed control.

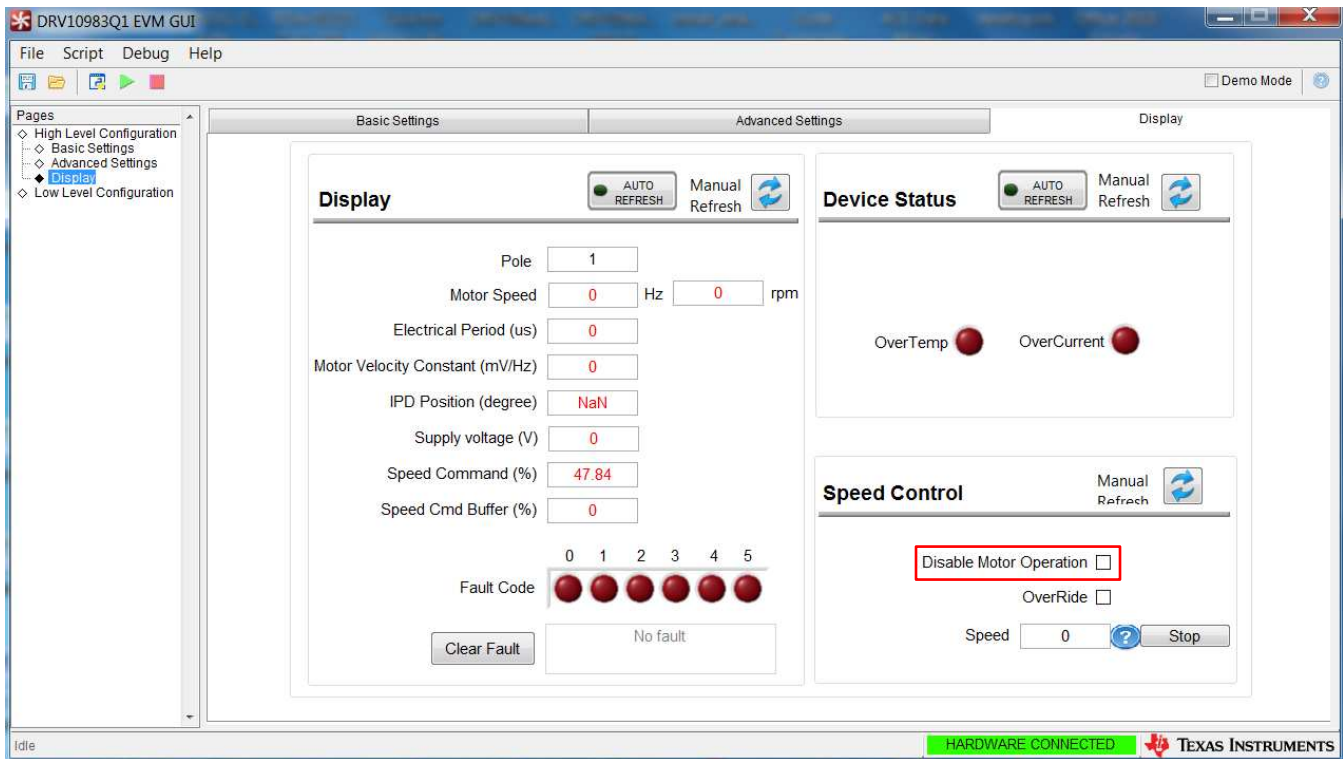

Figure 14. OverRide Selected

- Step 15. Enter values from 0 (stopped) to 511 (full speed) in the *Speed* text box to control the speed.
- Step 16. When complete, enter a value of 0 in the *Speed* text box and deselect the *OverRide* checkbox.

6 Power-On Sequence and Connection With User Specific Motor

The DRV10983-Q1 EVMs are shipped with default EEPROM settings for all registers, which may or may not be suitable to operate the target motor. To connect the user motor to the EVM, follow the steps listed in [Section 5](#) to avoid any damage to the EVM.

To successfully tune a user motor, refer to the [DRV10983-Q1 Tuning Guide](#).

7 Schematic and Bill of Materials

This section contains the DRV10983-Q1 schematic and bill of materials (BOM).

7.1 Schematic

Figure 15 shows the DRV10983-Q1 schematic.

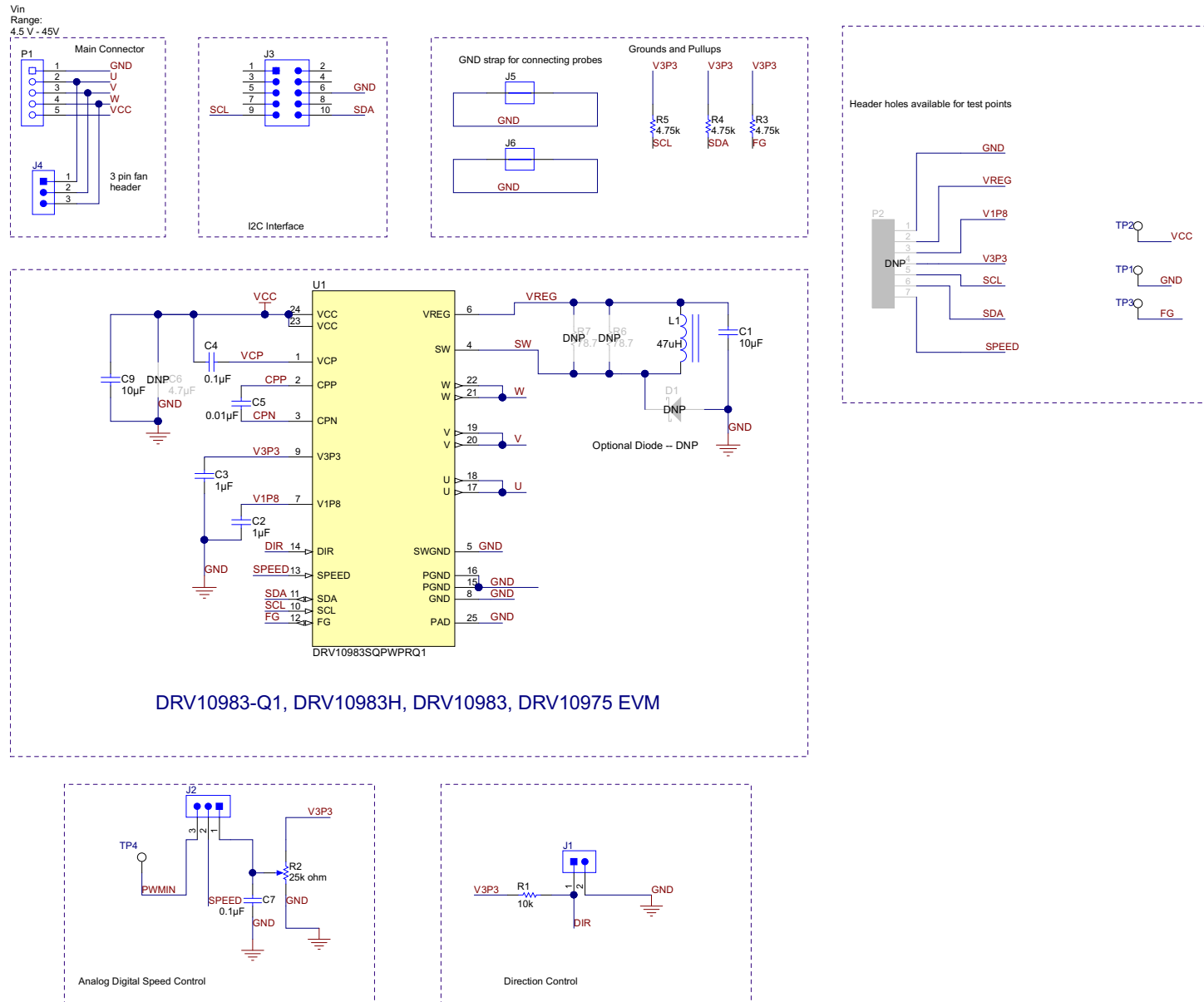

Copyright © 2017, Texas Instruments Incorporated

Figure 15. DRV10983-Q1 Schematic

7.2 Bill of Materials (BOM)

Table 6 lists the DRV10983-Q1 EVM bill of materials.

Table 6. DRV10983-Q1 Bill of Materials

Designator	Description	Manufacturer	Part Number	Quantity
!PCB ⁽¹⁾	Printed Circuit Board	TI	DRV10983Q1	1
C1	CAP, CERM, 10uF, 10V, ±20%, X5R, 0603	TDK	C1608X5R1A106M	1
C2, C3	CAP, CERM, 1uF, 25V, ±10%, X5R, 0603	TDK	C1608X5R1E105K080AC	2
C4, C7	CAP, CERM, 0.1uF, 50V, ±10%, X7R, 0603	AVX	06035C104KAT2A	2
C5	CAP CERM, 10000PF, 50V X7R 0603	AVX	06035C103KAT2A	1
C9	CAP, CERM, 10uF, 50V, ±10%, X5R, 1206	TDK	C2012X5R1H475K125AB	1
H9, H10, H11, H12	Bumpon, Hemisphere, 0.44 X 0.20, Clear	3M	SJ-5303 (CLEAR)	4
J1	Header, 100mil, 2x1, Tin plated, TH	Molex	90120-0122	1
J2, J4	Header, 100mil, 3x1, Tin plated, TH	Sullins Connector Solutions	PEC03SAAN	2
J3	Header (shrouded), 100mil, 5x2, Gold, TH	TE Connectivity	5103308-1	1
J5, J6	1mm Uninsulated Shorting Plug, 10.16mm spacing, TH	Harwin	D3082-05	1
L1	Inductor, Shielded, Ferrite, 47 µH, 1.15 A, 0.3 ohm, AEC-Q200 Grade 1, SMD	Wurth Elektronik	784777470	1
P1	Terminal Block, 5.08 mm, 5x1, Brass, TH	On-Shore Technology	ED120/5DS	1
R3, R4, R5	RES, 4.75k ohm, 1%, 0.1W, 0603	Vishay-Dale	CRCW06034K75FKEA	3
R2	Trimmer, 25k ohm, 0.15W, TH	CTS Electrocomponents	296XD253B1N	1
R1	RES, 10k ohm, 5%, 0.1W, 0603	Vishay-Dale	CRCW060310K0JNEA	1
SH-J1, SH-J2	Shunt, 100mil, Gold plated, Black	3M	969102-0000-DA	2
TP1, TP2, TP4	Test Point, Compact, SMT	Keystone	5016	3
TP3	Test Point, Compact, SMT	Keystone	5016	1
U1	Automotive, Three-Phase, Sensorless BLDC Motor Driver, PWP0024B	Texas Instruments	DRV10983PWP-Q1	1

⁽¹⁾ U1 part number is DRV10983-Q1.

GUI Installation and Overview

This appendix section explains the location and the procedure for installing the software.

NOTE: Ensure that no USB connections are made to the EVM until the installation is completed.

A.1 System Requirements

The system requirements are as follows:

- Supported OS: Microsoft® Windows® XP, Windows 7 (32 bit, 64 bit)
- Recommended RAM memory: 4GB or higher
- Recommended CPU operating speed: 3.3 GHz or higher

A.2 Installation Procedure

The following procedure describes how to install the DRV109xxEVM GUI. The installer also installs Python 2.7, USB2ANY SDK along with the GUI installation.

1. Double click on the Setup_DRV109xx_EVM.exe from the *DRV109xx* folder as shown in [Figure 16](#).

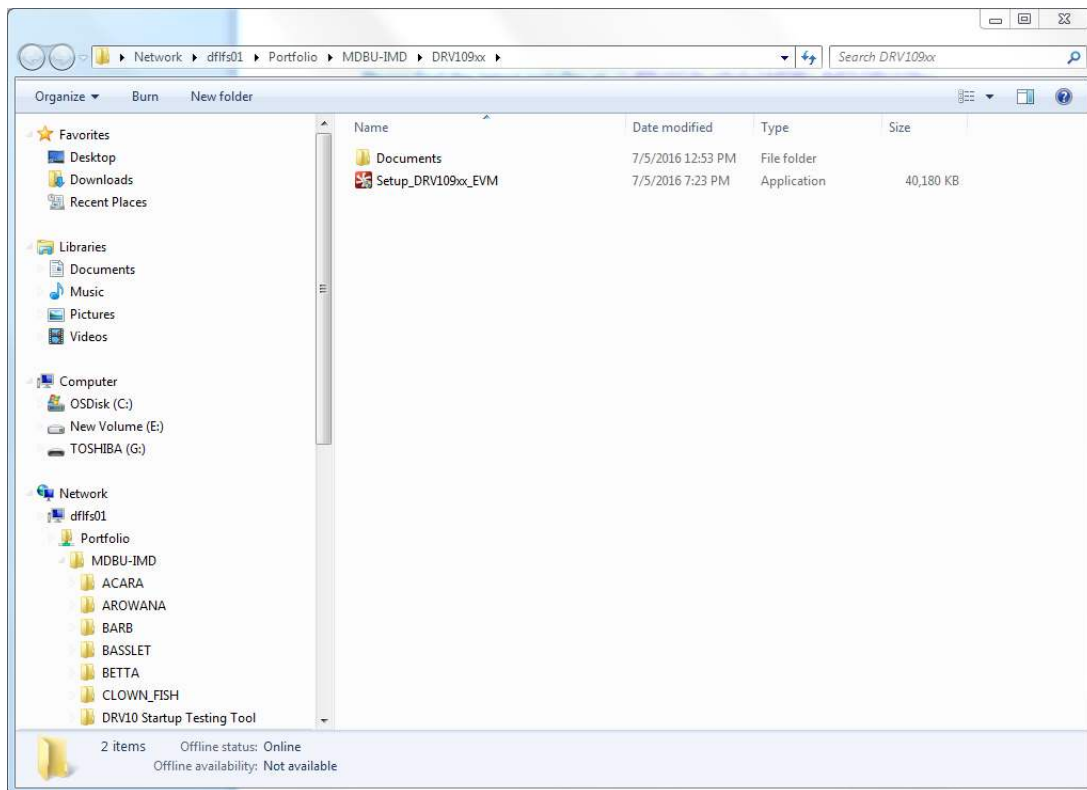

Figure 16. Setup_DRV109xx_EVM.exe from the Volume Folder

2. The *Setup* window is displayed as shown in [Figure 17](#). Click the *Next >* button to begin the setup

wizard.

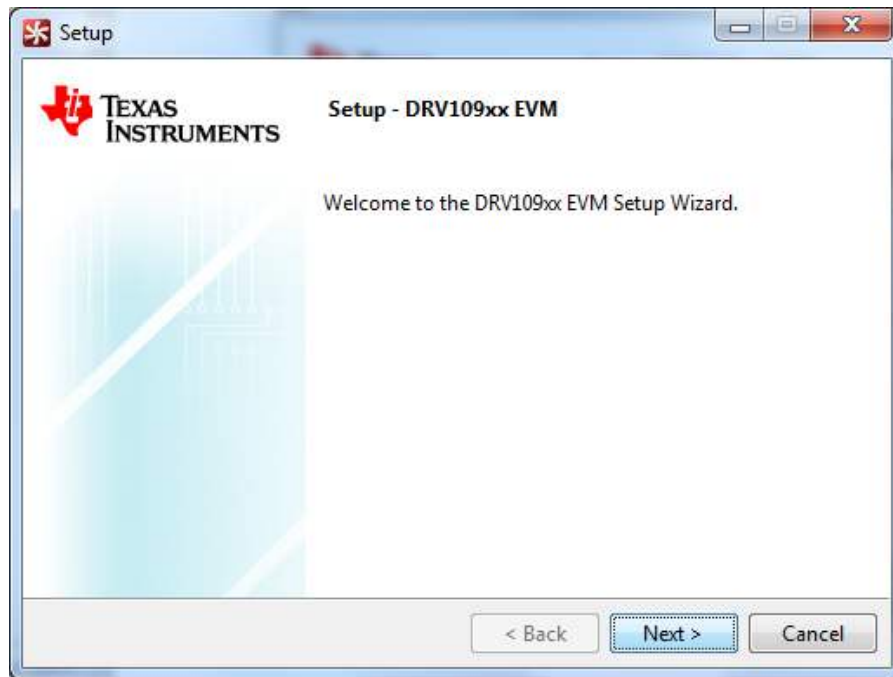

Figure 17. GUI Installation Initialization

3. The license agreement is displayed next as shown in [Figure 18](#). Read through the agreement carefully and select the *I accept the agreement* radio button and then click the *Next >* button to proceed to the next step.



Figure 18. License Agreement

4. Set the destination directories for the GUI installation and click the *Next >* as shown in [Figure 19](#). TI recommends to keep the default values as provided in the installer.

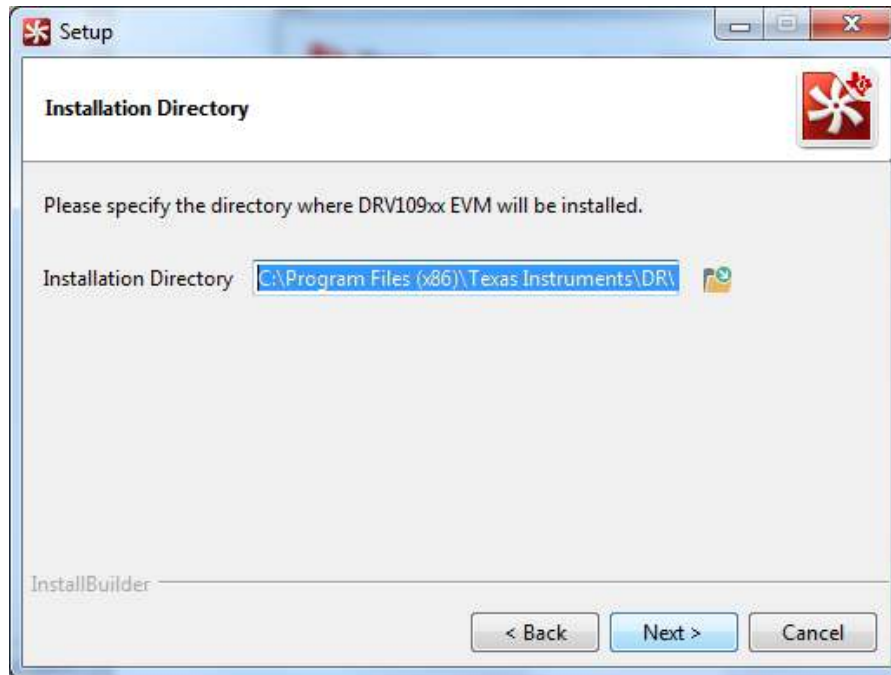

Figure 19. GUI Destination Directory

5. The *Ready to Install* window appears next as shown in [Figure 20](#). Click the *Next >* to begin installation.

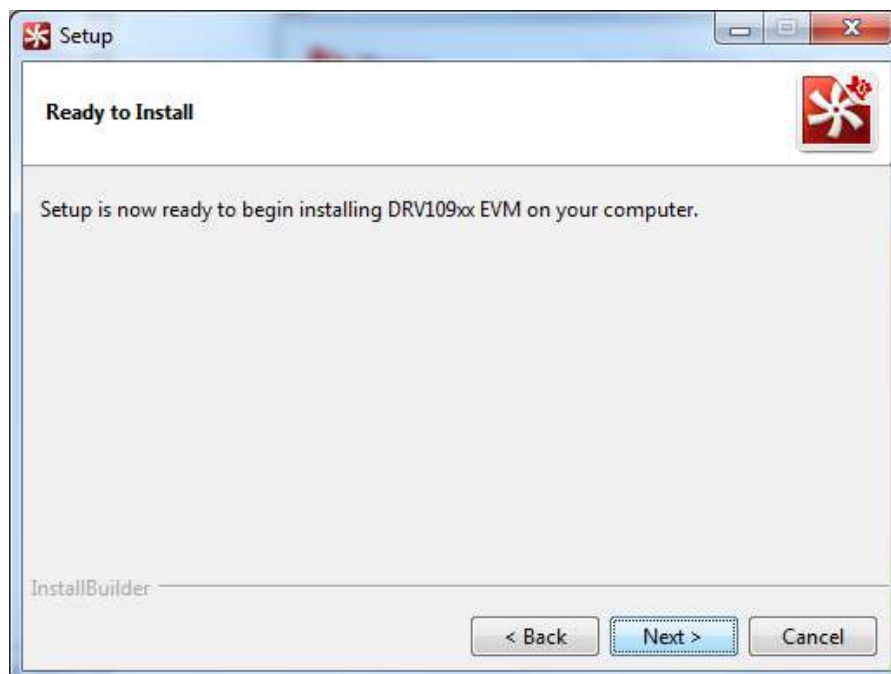

Figure 20. GUI Start Installation

- The installer begins self-extraction and proceeds with the installation as shown in [Figure 21](#).

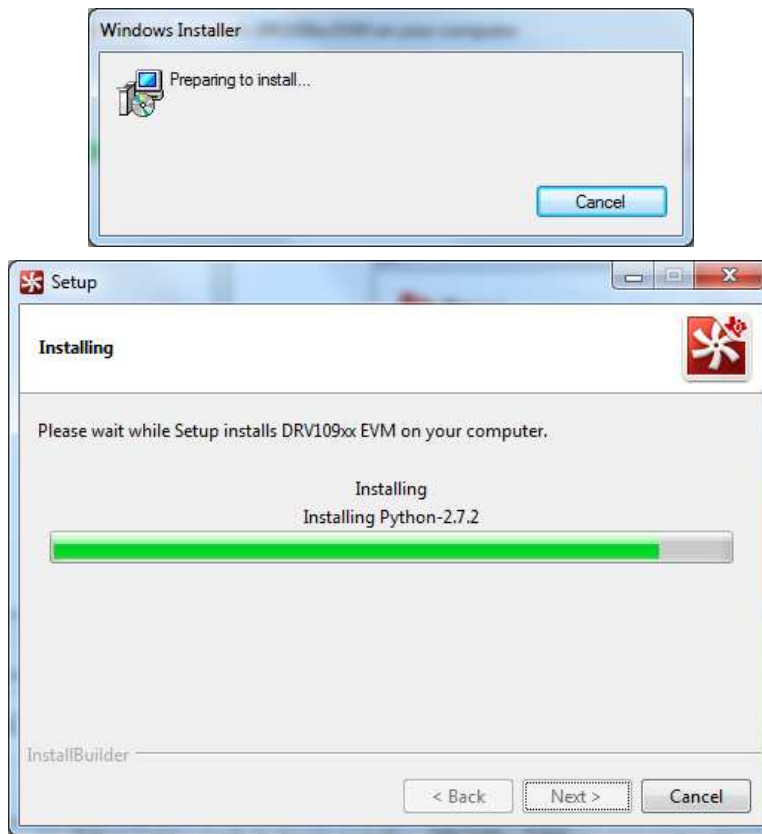

Figure 21. GUI Installation in Progress

- After the installation of the GUI, the Python installation initiates. When Python is installed, a the window shown in [Figure 22](#) is displayed. Click the *Finish* button to proceed with the USB2ANY installation.



Figure 22. Python Installation Complete

- The setup window for the USB2ANY installation is displayed as shown in Figure 23. Click the *Next >* button to proceed with the initialization.

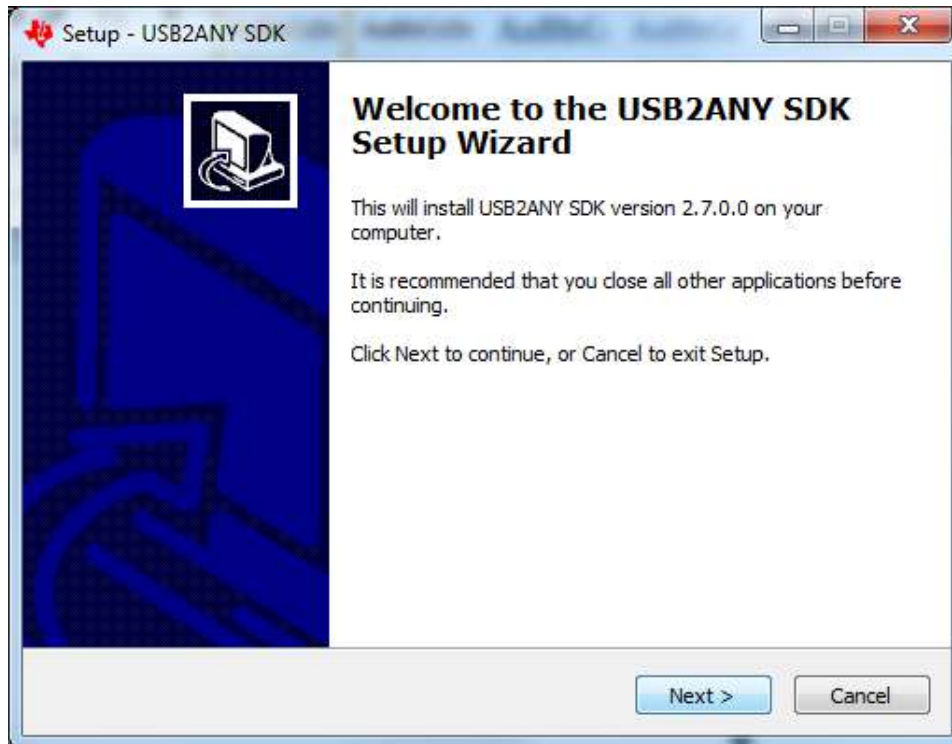

Figure 23. USB2ANY Installation Initialization

- The license agreement is displayed next as shown in Figure 24. Read through the agreement carefully and select the *I accept the agreement* radio button and then click the *Next >* button to proceed.



Figure 24. USB2ANY License Agreement

10. Set the destination directories for the USB2ANY installation and click the *Next >* as shown in [Figure 25](#).

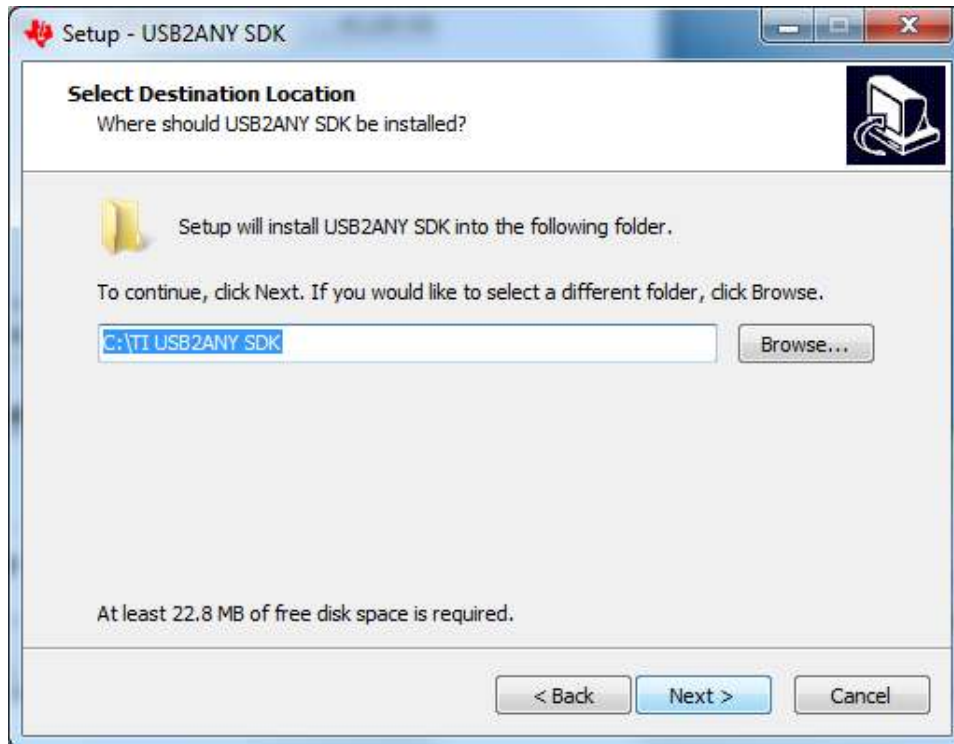

Figure 25. USB2ANY Destination Directory

11. The *Ready to Install* window is displayed next as shown in [Figure 26](#). Click the *Install* button to begin the USB2ANY installation.

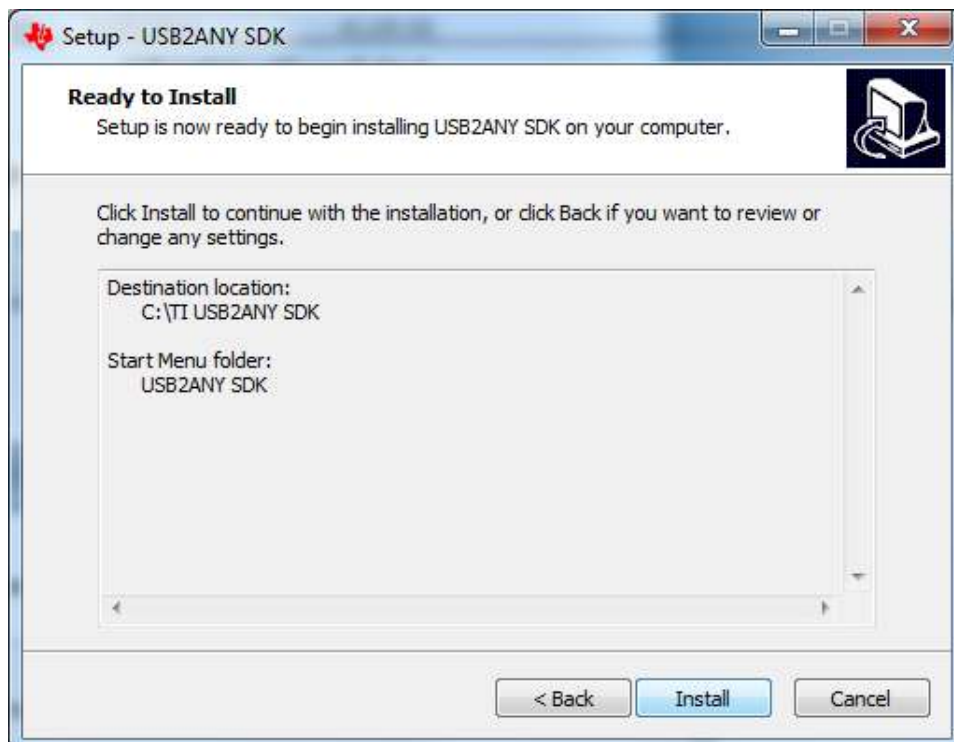

Figure 26. USB2ANY Start Installation

12. The installer begins self-extraction and proceeds with the installation.
13. When the USB2ANY installation is complete, the window show in [Figure 27](#) is displayed, indicating the completion of the USB2ANY installation. Click the *Finish* button.



Figure 27. USB2ANY Installation Complete

NOTE: The DRV10983-Q1 GUI requires the LabVIEW Run-Time Engine 2010 to be installed before the GUI is executed.

The DRV10983-Q1 GUI installer does not include the LabVIEW Run-Time Engine. Go to <http://www.ni.com/download/labview-run-time-engine-2014/4887/en/> to download the National Instruments LabVIEW Run-Time Engine.

A.3 GUI Overview

The DRV10983-Q1 GUI was developed to communicate with the device to configure different registers within the device, and to understand the response based on the configurations. The following sections describe some of the specific features of the GUI, but do not explain the configurations of the controls and indicators.

Screen captures of the DRV10983 GUI are provided to explain the various features of the GUI. The same images apply to the DRV10975 devices unless otherwise specified.

A.3.1 Components of the GUI

The device GUI contains three pages (or tabs):

- *Basic Settings*
- *Advanced Settings*
- *Display*

A.3.1.1 Basic Settings

Figure 28 shows the *Basic Settings* tab of the GUI.

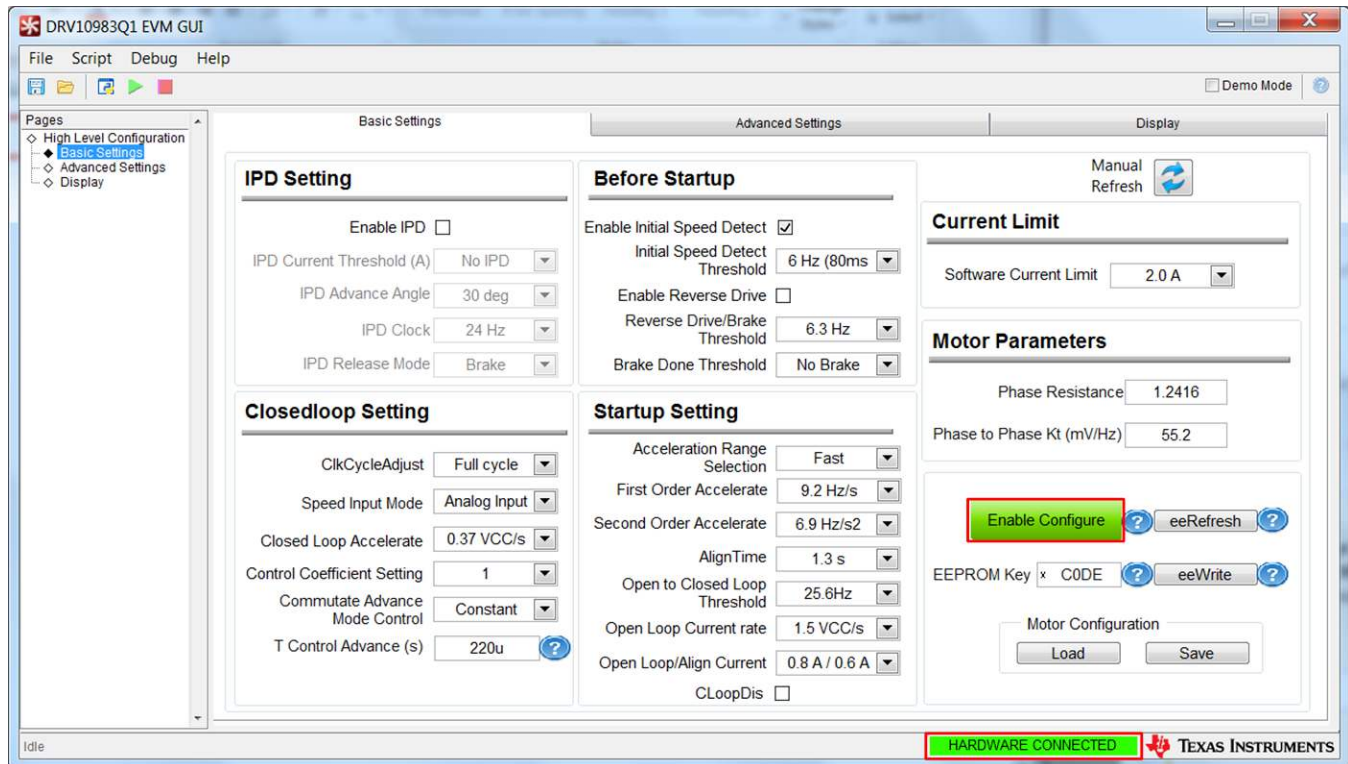

Figure 28. Basic Settings Page

A.3.1.1.1 Enable Configure

The controls in the *Basic Settings* tab and *Advanced Settings* tab are only enabled if the *Enable Configure* button is selected. This button specifies the data use between the registers and EEPROM. Click on the button to select the data use. If the *Enable Configure* button is enabled (the control turns green in color), the register data is used, or else (the control turns red) the EEPROM data is used.

A.3.1.1.2 Enable IPD

Clicking the *Enable IPD* checkbox enables and disables the controls related to IPD settings. If this control is disabled, a value 0 is written to the IPD current threshold. If the control is enabled, a value 1 is written to IPD current threshold field.

A.3.1.1.3 eeWrite

The *eeWrite* button programs to the EEPROM. When this control is clicked, a prompt message asks for confirmation of the voltage level (see Figure 29). The *eeWrite* field is written only if the *EEPROM Key* field is set to *CODE*, and the power supply voltage level is confirmed.

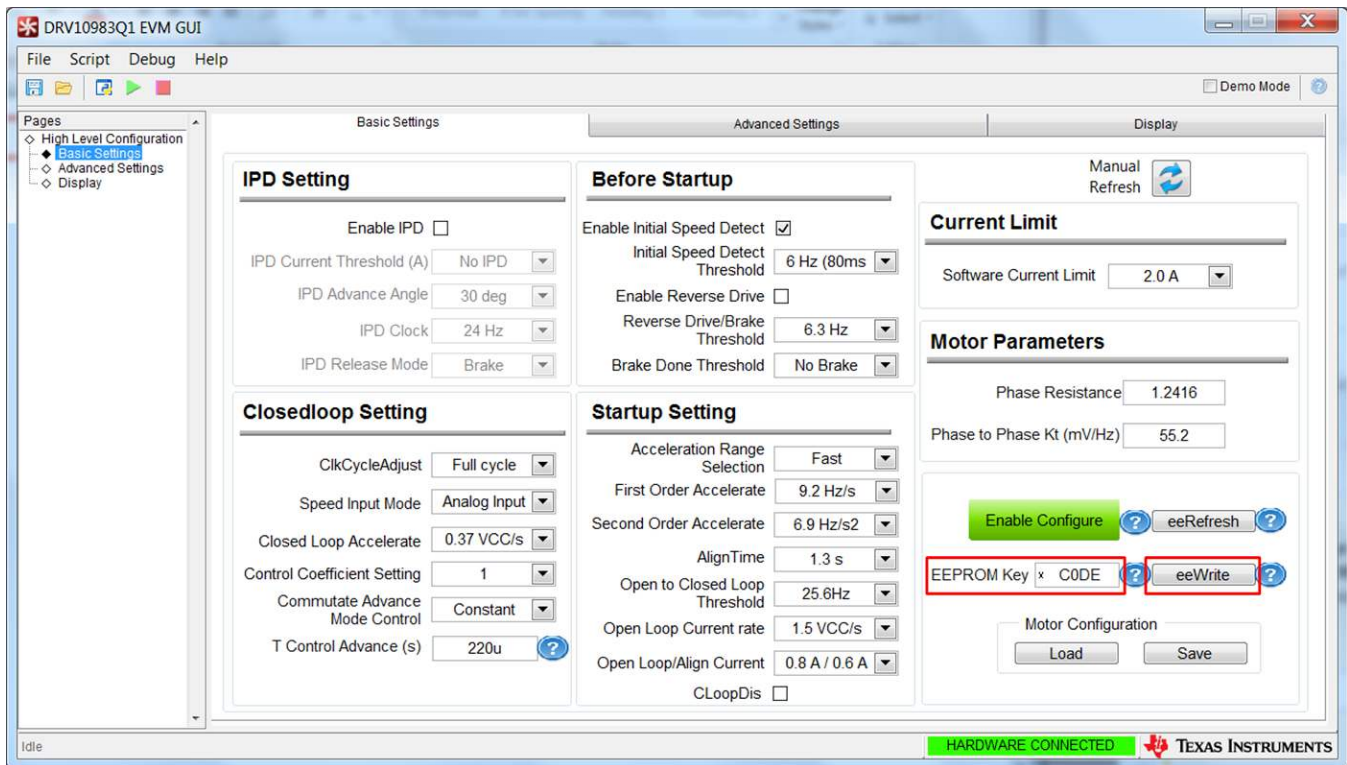

Figure 29. Confirmation on Voltage Level

A.3.1.1.4 eeRefresh

The *eeRefresh* button refreshes the controls in the *Basic Settings* tab, which reads the latest value of the corresponding fields from the registers and updates the controls.

A.3.1.1.5 Manual Refresh

The *Manual Refresh* button refreshes the controls in the *Motor Parameters* section, which reads the latest value of the corresponding fields from the registers and updates the controls. The function of this button is same in every section.

A.3.1.1.6 Save Motor Configuration

The *Save Motor Configuration* button saves the current motor configuration to a file that is later loaded into the GUI using the *Load* button. The button saves the last read values of the registers. Perform a manual refresh operation before saving the configurations into a file.

A.3.1.1.7 Load Motor Configuration

The *Load Motor Configuration* button loads the configuration file saved earlier, to bring the device to a known state.

A.3.1.1.8 Help Icon

Move the mouse over the blue help icon to display a brief description for the control, as shown in [Figure 30](#).



Figure 30. Help Icon

A.3.1.2 Advanced Settings

The *Advanced Settings* tab contains controls to handle the frequency overflow, Current Limit for Lock Detection, FG motor pole option, and so forth (see [Figure 31](#)).



Figure 31. Advanced Settings

A.3.1.3 Display

The *Display* tab (see [Figure 32](#)) contains controls to handle the motor speed, indicates the status of the device, and displays the value of motor attributes such as motor speed, current, and IPD position.

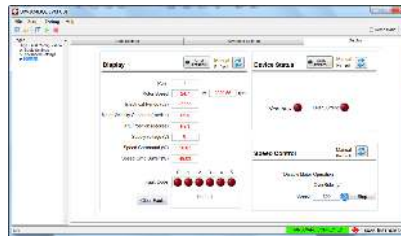

Figure 32. Display

A.3.1.3.1 Auto Refresh

The *Auto Refresh* button periodically refreshes the controls of the motor parameters, which read the latest value of the corresponding fields from the registers and update the controls. The rate of auto refresh is specified in the configuration file found parallel to the application. The function of this button is same in every section.

A.3.1.3.2 Pole

The number entered into the *Pole* text field is used to calculate the RPM in the *Display* section, given by the formula in [Equation 1](#).

If motor speed (Hz) ≥ 2 , motor speed (rpm) = (1 000 000 / electrical period [μ s]) \times 120/pole. Else, motor speed (rpm) = motor speed (Hz) \times 120/pole.

The default value of this control is 1. (1)

A.3.1.3.3 Stop

The *Stop* button writes the speed control with a value of 0.

A.3.1.3.4 About

The *About* window provides the details like the GUI version, supported OS, and the firmware version of the USB2ANY.

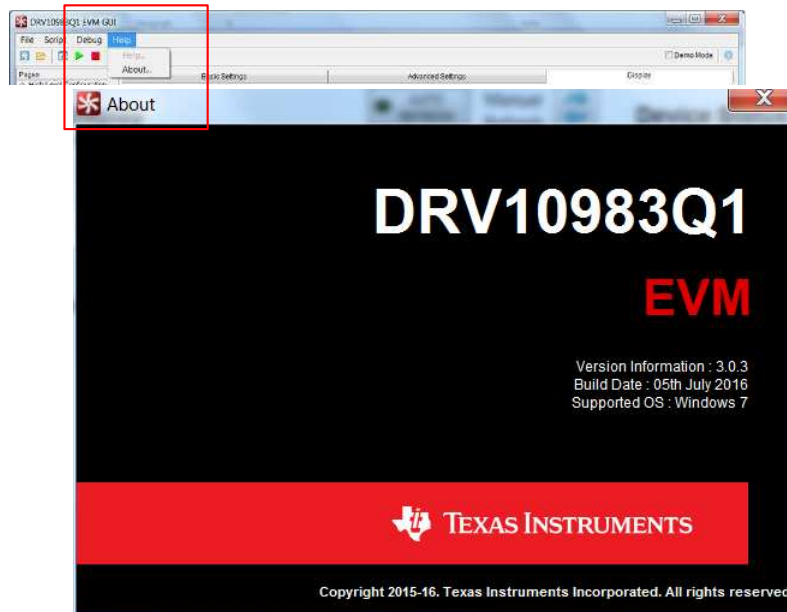

Figure 33. About Page

A.3.2 Menu Options

A.3.2.1 File

The *File* menu contains the *Exit* option as shown in Figure 34. The *Exit* option stops the execution of the DRV10983Q1 EVM GUI.



Figure 34. File Menu

A.3.2.2 Script

Scripting automates the device operations and reduces the time consumption in repeating similar operations.

Scripting is helpful in situations where performing a particular device function requires setting 10 to 15 registers on the device to a particular value. In these circumstances, scripts can be recorded and run whenever needed.

In DRV10983Q1 EVM GUI, the scripting occurs using Python.

A.3.2.2.1 Recording and Running Scripts

Use the following steps to record and run the scripts:

- Step 1. Go to the *Script* menu in the DRV10983Q1 EVM GUI and select the *Launch Script* option to start recording or click the *Launch Script Window* button as shown in Figure 35.

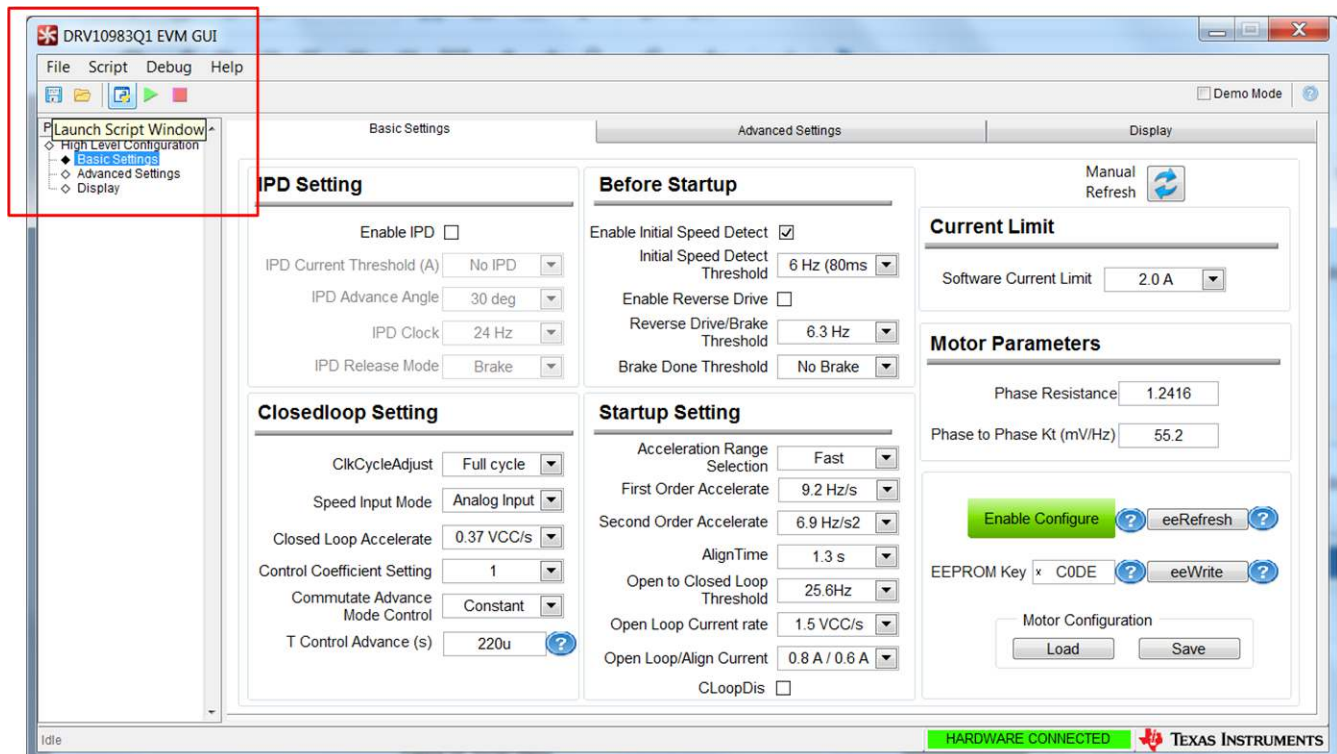

Figure 35. Script Menu

An untitled, empty Python window opens in the Idle IDE (see [Figure 36](#)).

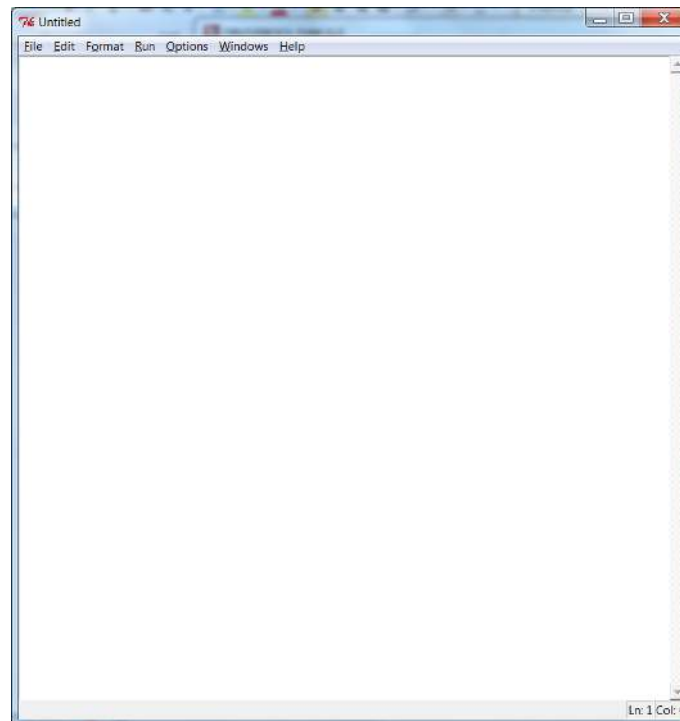

Figure 36. Launch Macro

When the Idle IDE Python window appears, the *Start Recording* option is enabled under the *Script* menu. The *Start Recording* button is also available as shown in [Figure 37](#).

- Step 2. Select the *Launch Script Window* option again to open another untitled window. The window that was last opened is the active window.
- Step 3. In the GUI window, go to the *Scripts* menu and select the *Start Recording* option from the menu.

All actions performed on the GUI are recorded in the Idle IDE Python window. The recording function is indicated in the untitled Idle IDE Python window when the window flashes green, while the window is recording as shown in [Figure 37](#).

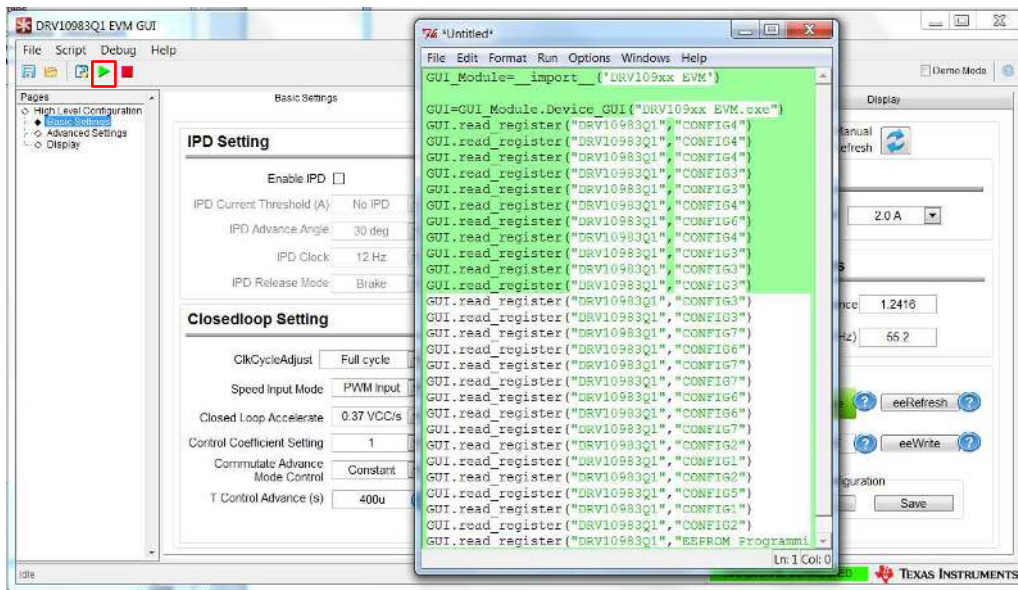

Figure 37. Start Recording

The Idle IDE Python window captures predefined actions only. While recording, no action, such as moving the cursor or entering data, has to be performed in the Idle IDE Python window. To stop recording, go to the *Script* menu in the DRV10983Q1 EVM GUI and select the *Stop Recording* option from the menu or click the *Stop Recording* button as shown in Figure 38.

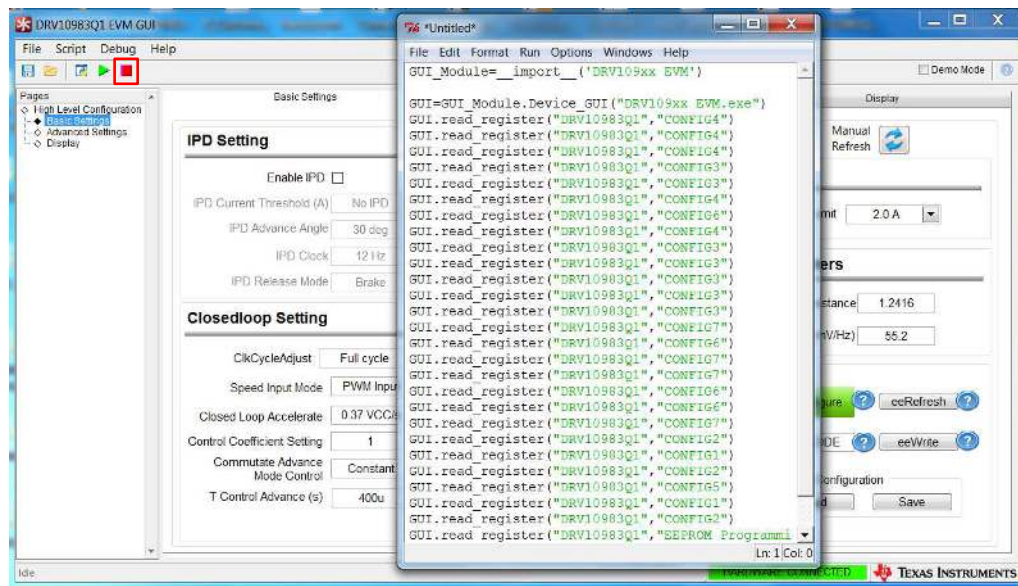

Figure 38. Stop Recording

The *Launch Script Window* remains open after the recording has been stopped as shown in Figure 38. This window can be closed with or without saving. To save the script, it must be saved with extension .py under the script folder.

To run the script, go to the *Run* menu and select the *Run Module* option in the untitled Idle IDE Python window as shown in Figure 39.

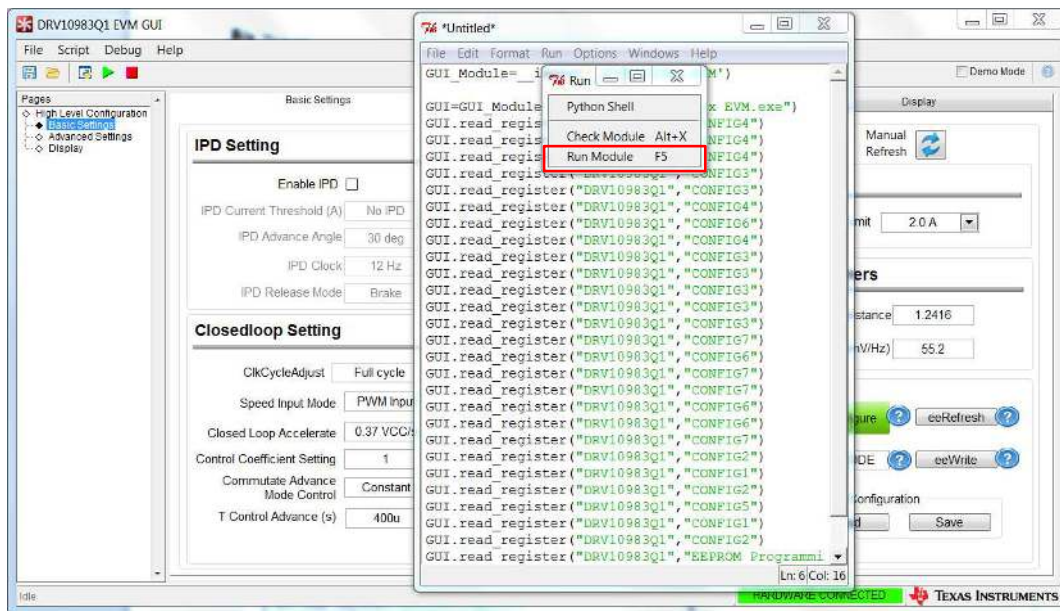

Figure 39. Run Macro

The script runs and displays the following message in the Idle IDE Python window: *Script completed successfully.*

To run a saved script, go to the *File* menu and select the *Open* option in the Idle IDE Python window. Select the file from the *Scripts* folder.

A.3.2.2.2 Debug

The debug option is used for the following operations:

Simulation — Selecting the *Demo* menu option runs the GUI in demo mode. Unselecting *Demo* mode runs the GUI in connected mode.

Debugging — The *Debug Log* menu option logs all user activities. If not selected, only the high-level operations are logged.

File logging — The *Log to File* menu option logs the GUI activities to a specified log file.

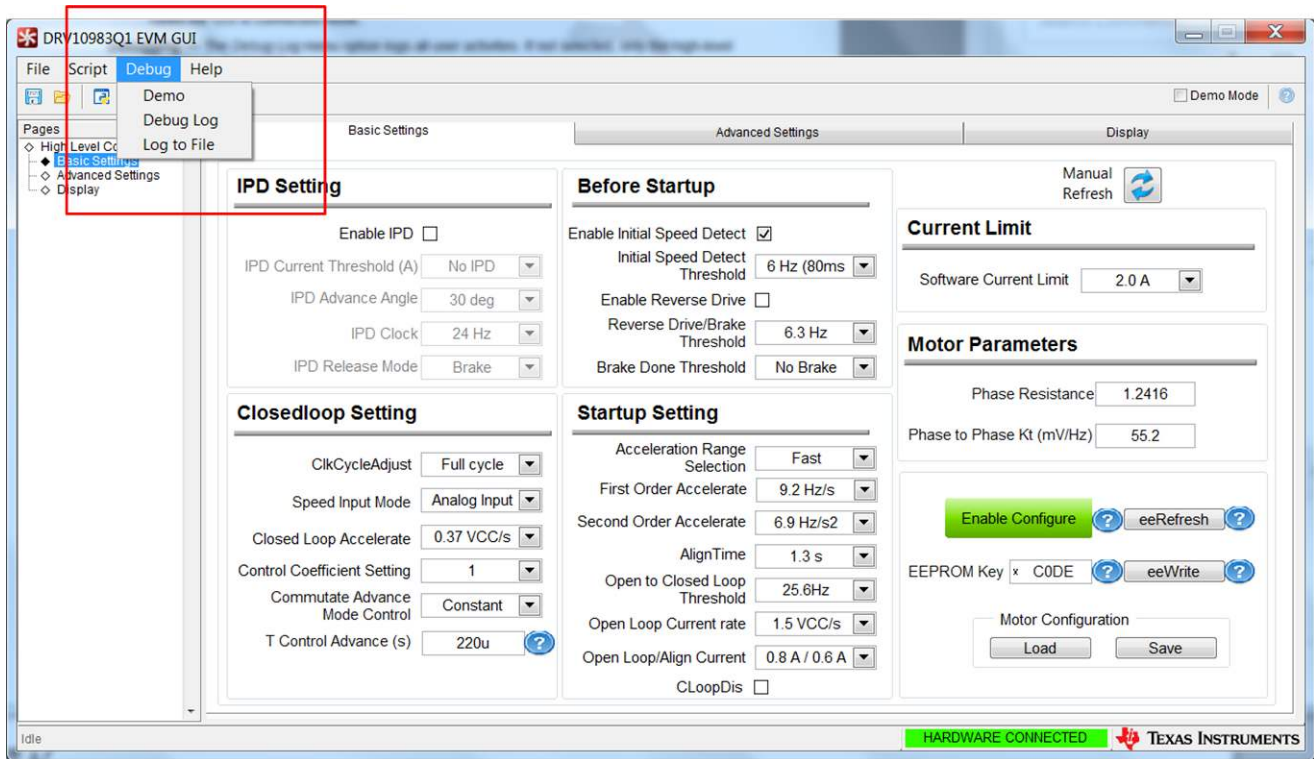

Figure 40. Debug Menu

GUI to DRV10983-Q1 Register Cross Reference

The DRV10983-Q1 register names and GUI names do not always match. [Table 7](#) provides a cross reference between the different names. The tab and section location of the register values in the GUI is also provided.

Table 7. GUI to DRV10983-Q1 Register Cross Reference

Registers			GUI		
Register Name	Address	Register Map	Tab	Section	GUI Name
CONFIG1	0x90	SSMConfig[1:0]	Advance	Device Options	Spread spectrum Modulation
		FGOLSel[1:0]	Advance	FG Options	FG Open Loop Output Select
		FGCycle[3:0]	Advance	FG Options	FG Cycle Selection
		ClkCycleAdjust	Basic	Closedloop Setting	ClkCycleAdjust
		RMSHift[2:0] RMValue[3:0]	Basic	Motor Parameters	Phase Resistance
CONFIG2	0x91	KtShift[2:0]KtValue[3:0]	Basic	Motor Parameters	Phase to Phase Kt (mV/Hz)
		CommAdvMode	Basic	Closedloop Setting	Commutate Advanced Mode Control
		TCtrlAdvShift[2:0]TCtrlAdvValue[3:0]	Basic	Closedloop setting	T Control Advanced (s)
CONFIG3	0x92	ISDThr[1:0]	Basic	Before Startup	Initial Speed Detect Threshold
		ISDEn	Basic	Before Startup	Enable Initial Speed Detect
		RvsDrEn	Basic	Before Startup	Enable Reserve Drive
		RvsDrThr[1:0]	Basic	Before Startup	Reserve Drive/Brake Threshold
		OpenLCurr[1:0]	Basic	Startup Setting	Open Loop / Align Current
		OpLCurrRt[2:0]	Basic	Startup Setting	Open Loop Current rate
		BrkDoneThr[2:0]	Basic	Before Startup	Break Done Threshold
CONFIG4	0x93	AccelRangeSel	Basic	Startup Setting	Acceleration Range Selection
		StAccel2[2:0]	Basic	Startup Setting	Second Order Accelerate
		StAccel[2:0]	Basic	Startup Setting	First Order Accelerate
		Op2ClsThr[4:0]	Basic	Startup Setting	Open to Closed Loop Threshold
		AlignTime[2:0]	Basic	Startup Setting	Align Time
CONFIG5	0x94	OTWarning_ILimit[1:0]	Advanced	Device Options	Temp Warning Action
		LockEn5	Advanced	Lock Detect	Closed Loop Stuck
		LockEn4	Advanced	Lock Detect	Open Loop Stuck
		LockEn3	Advanced	Lock Detect	No Motor Fault
		LockEn2	Advanced	Lock Detect	BEMF Abnormal
		LockEn1	Advanced	Lock Detect	Speed Abnormal
		LockEn0	Advanced	Lock Detect	Current Limit
		SwLimit[3:0]	Basic	Current ILimit	Software Current Limit
		HwLimit[2:0]	Advanced	Lock Detect	Current Limit for Lock Detection
IPDasHwLimit	Advanced	Lock Detect	Current Limit for Lock Detection Control		

Table 7. GUI to DRV10983-Q1 Register Cross Reference (continued)

Registers			GUI		
Register Name	Address	Register Map	Tab	Section	GUI Name
CONFIG6	0x95	SpdCtrlMd	Basic	Closedloop Setting	Speed Input Mode
		PWMFreq	Advanced	PWM output Options	Double the output PWM frequency
		KtLckThr[1:0]	Advanced	Lock Detect	Abnormal Kt lock detect Threshold
		AvSlndEn	Advanced	AVS (Anti-voltage Surge) Function	Enable Inductive AVS
		AVSMEn	Advanced	AVS (Anti-voltage Surge) Function	Enable Mechanical AVS
		AVSMMd	Advanced	AVS (Anti-voltage Surge) Function	Mechanical AVS Mode
		IPDRlsMd	Basic	IPD Setting	IPD Release Mode
		CLoopDis	Basic	Startup Setting	CLoopDis
		ClsLpAccl[2:0]	Basic	Closedloop Setting	Closed loop Accelerate
		DutyCycleLimit[1:0]	Advanced	Device Options	Duty Cycle Limit
		SlewRate[1:0]	Advanced	Device Options	Slew Rate
CONFIG7	0x96	IPDAdvAg[1:0]	Basic	IPD Setting	IPD Advanced Angle
		IPDCurrThr[3:0]	Basic	IPD Setting	IPD Current Threshold (A)
		IPDClk[1:0]	Basic	IPD Setting	IPD Clock
		CtrlCoef[1:0]	Basic	Closedloop Setting	Control Coefficient Setting
		DeadTime[4:0]	Advanced	PWM output Options	Driver Dead Time
EEPROM Programming5	0x35	ShadowRegEn	Basic		Enable Configure
		eeWRnEn	Basic		eeWrite
		eeRefresh	Basic		eeRefresh
EEPROM Programming1	0x31	ENPROGKEY[15:0]	Basic		EEPROM Key
SpeedCtrl	0x30	OverRide	Display	Speed Control	OverRide
		SpeedCtrl[8:0]	Display	Speed Control	Speed
MTD_TEST1	0x60	SCORE_DIS	Display	Speed Control	Disable Motor Operation

Revision History

NOTE: Page numbers for previous revisions may differ from page numbers in the current version.

Changes from Original (June 2017) to A Revision	Page
• Changed <i>R14</i> to <i>R2</i> globally throughout the user's guide.	1
• Changed the <i>L1</i> designator description, manufacturer, and part number in the BOM.....	17
• Changed the <i>R3</i> , <i>R4</i> , <i>R5</i> designator in the BOM from <i>R5</i> , <i>R6</i> , <i>R7</i>	17
• Changed the <i>R2</i> designator in the BOM from <i>R14</i>	17
• Changed the <i>R1</i> designator in the BOM from <i>R15</i>	17

STANDARD TERMS FOR EVALUATION MODULES

1. *Delivery:* TI delivers TI evaluation boards, kits, or modules, including any accompanying demonstration software, components, and/or documentation which may be provided together or separately (collectively, an "EVM" or "EVMs") to the User ("User") in accordance with the terms set forth herein. User's acceptance of the EVM is expressly subject to the following terms.
 - 1.1 EVMs are intended solely for product or software developers for use in a research and development setting to facilitate feasibility evaluation, experimentation, or scientific analysis of TI semiconductor products. EVMs have no direct function and are not finished products. EVMs shall not be directly or indirectly assembled as a part or subassembly in any finished product. For clarification, any software or software tools provided with the EVM ("Software") shall not be subject to the terms and conditions set forth herein but rather shall be subject to the applicable terms that accompany such Software
 - 1.2 EVMs are not intended for consumer or household use. EVMs may not be sold, sublicensed, leased, rented, loaned, assigned, or otherwise distributed for commercial purposes by Users, in whole or in part, or used in any finished product or production system.
2. *Limited Warranty and Related Remedies/Disclaimers:*
 - 2.1 These terms do not apply to Software. The warranty, if any, for Software is covered in the applicable Software License Agreement.
 - 2.2 TI warrants that the TI EVM will conform to TI's published specifications for ninety (90) days after the date TI delivers such EVM to User. Notwithstanding the foregoing, TI shall not be liable for a nonconforming EVM if (a) the nonconformity was caused by neglect, misuse or mistreatment by an entity other than TI, including improper installation or testing, or for any EVMs that have been altered or modified in any way by an entity other than TI, (b) the nonconformity resulted from User's design, specifications or instructions for such EVMs or improper system design, or (c) User has not paid on time. Testing and other quality control techniques are used to the extent TI deems necessary. TI does not test all parameters of each EVM. User's claims against TI under this Section 2 are void if User fails to notify TI of any apparent defects in the EVMs within ten (10) business days after delivery, or of any hidden defects with ten (10) business days after the defect has been detected.
 - 2.3 TI's sole liability shall be at its option to repair or replace EVMs that fail to conform to the warranty set forth above, or credit User's account for such EVM. TI's liability under this warranty shall be limited to EVMs that are returned during the warranty period to the address designated by TI and that are determined by TI not to conform to such warranty. If TI elects to repair or replace such EVM, TI shall have a reasonable time to repair such EVM or provide replacements. Repaired EVMs shall be warranted for the remainder of the original warranty period. Replaced EVMs shall be warranted for a new full ninety (90) day warranty period.
3. *Regulatory Notices:*
 - 3.1 *United States*
 - 3.1.1 *Notice applicable to EVMs not FCC-Approved:*

FCC NOTICE: This kit is designed to allow product developers to evaluate electronic components, circuitry, or software associated with the kit to determine whether to incorporate such items in a finished product and software developers to write software applications for use with the end product. This kit is not a finished product and when assembled may not be resold or otherwise marketed unless all required FCC equipment authorizations are first obtained. Operation is subject to the condition that this product not cause harmful interference to licensed radio stations and that this product accept harmful interference. Unless the assembled kit is designed to operate under part 15, part 18 or part 95 of this chapter, the operator of the kit must operate under the authority of an FCC license holder or must secure an experimental authorization under part 5 of this chapter.
 - 3.1.2 *For EVMs annotated as FCC – FEDERAL COMMUNICATIONS COMMISSION Part 15 Compliant:*

CAUTION

This device complies with part 15 of the FCC Rules. Operation is subject to the following two conditions: (1) This device may not cause harmful interference, and (2) this device must accept any interference received, including interference that may cause undesired operation.

Changes or modifications not expressly approved by the party responsible for compliance could void the user's authority to operate the equipment.

FCC Interference Statement for Class A EVM devices

NOTE: This equipment has been tested and found to comply with the limits for a Class A digital device, pursuant to part 15 of the FCC Rules. These limits are designed to provide reasonable protection against harmful interference when the equipment is operated in a commercial environment. This equipment generates, uses, and can radiate radio frequency energy and, if not installed and used in accordance with the instruction manual, may cause harmful interference to radio communications. Operation of this equipment in a residential area is likely to cause harmful interference in which case the user will be required to correct the interference at his own expense.

FCC Interference Statement for Class B EVM devices

NOTE: This equipment has been tested and found to comply with the limits for a Class B digital device, pursuant to part 15 of the FCC Rules. These limits are designed to provide reasonable protection against harmful interference in a residential installation. This equipment generates, uses and can radiate radio frequency energy and, if not installed and used in accordance with the instructions, may cause harmful interference to radio communications. However, there is no guarantee that interference will not occur in a particular installation. If this equipment does cause harmful interference to radio or television reception, which can be determined by turning the equipment off and on, the user is encouraged to try to correct the interference by one or more of the following measures:

- Reorient or relocate the receiving antenna.
- Increase the separation between the equipment and receiver.
- Connect the equipment into an outlet on a circuit different from that to which the receiver is connected.
- Consult the dealer or an experienced radio/TV technician for help.

3.2 Canada

3.2.1 For EVMs issued with an Industry Canada Certificate of Conformance to RSS-210 or RSS-247

Concerning EVMs Including Radio Transmitters:

This device complies with Industry Canada license-exempt RSSs. Operation is subject to the following two conditions:

(1) this device may not cause interference, and (2) this device must accept any interference, including interference that may cause undesired operation of the device.

Concernant les EVMs avec appareils radio:

Le présent appareil est conforme aux CNR d'Industrie Canada applicables aux appareils radio exempts de licence. L'exploitation est autorisée aux deux conditions suivantes: (1) l'appareil ne doit pas produire de brouillage, et (2) l'utilisateur de l'appareil doit accepter tout brouillage radioélectrique subi, même si le brouillage est susceptible d'en compromettre le fonctionnement.

Concerning EVMs Including Detachable Antennas:

Under Industry Canada regulations, this radio transmitter may only operate using an antenna of a type and maximum (or lesser) gain approved for the transmitter by Industry Canada. To reduce potential radio interference to other users, the antenna type and its gain should be so chosen that the equivalent isotropically radiated power (e.i.r.p.) is not more than that necessary for successful communication. This radio transmitter has been approved by Industry Canada to operate with the antenna types listed in the user guide with the maximum permissible gain and required antenna impedance for each antenna type indicated. Antenna types not included in this list, having a gain greater than the maximum gain indicated for that type, are strictly prohibited for use with this device.

Concernant les EVMs avec antennes détachables

Conformément à la réglementation d'Industrie Canada, le présent émetteur radio peut fonctionner avec une antenne d'un type et d'un gain maximal (ou inférieur) approuvé pour l'émetteur par Industrie Canada. Dans le but de réduire les risques de brouillage radioélectrique à l'intention des autres utilisateurs, il faut choisir le type d'antenne et son gain de sorte que la puissance isotrope rayonnée équivalente (p.i.r.e.) ne dépasse pas l'intensité nécessaire à l'établissement d'une communication satisfaisante. Le présent émetteur radio a été approuvé par Industrie Canada pour fonctionner avec les types d'antenne énumérés dans le manuel d'usage et ayant un gain admissible maximal et l'impédance requise pour chaque type d'antenne. Les types d'antenne non inclus dans cette liste, ou dont le gain est supérieur au gain maximal indiqué, sont strictement interdits pour l'exploitation de l'émetteur.

3.3 Japan

3.3.1 *Notice for EVMs delivered in Japan:* Please see http://www.tij.co.jp/lstds/ti_ja/general/eStore/notice_01.page 日本国内に輸入される評価用キット、ボードについては、次のところをご覧ください。
http://www.tij.co.jp/lstds/ti_ja/general/eStore/notice_01.page

3.3.2 *Notice for Users of EVMs Considered "Radio Frequency Products" in Japan:* EVMs entering Japan may not be certified by TI as conforming to Technical Regulations of Radio Law of Japan.

If User uses EVMs in Japan, not certified to Technical Regulations of Radio Law of Japan, User is required to follow the instructions set forth by Radio Law of Japan, which includes, but is not limited to, the instructions below with respect to EVMs (which for the avoidance of doubt are stated strictly for convenience and should be verified by User):

1. Use EVMs in a shielded room or any other test facility as defined in the notification #173 issued by Ministry of Internal Affairs and Communications on March 28, 2006, based on Sub-section 1.1 of Article 6 of the Ministry's Rule for Enforcement of Radio Law of Japan,
2. Use EVMs only after User obtains the license of Test Radio Station as provided in Radio Law of Japan with respect to EVMs, or
3. Use of EVMs only after User obtains the Technical Regulations Conformity Certification as provided in Radio Law of Japan with respect to EVMs. Also, do not transfer EVMs, unless User gives the same notice above to the transferee. Please note that if User does not follow the instructions above, User will be subject to penalties of Radio Law of Japan.

【無線電波を送信する製品の開発キットをお使いになる際の注意事項】 開発キットの中には技術基準適合証明を受けていないものがあります。技術適合証明を受けていないものご使用に際しては、電波法遵守のため、以下のいずれかの措置を取っていただく必要がありますのでご注意ください。

1. 電波法施行規則第6条第1項第1号に基づく平成18年3月28日総務省告示第173号で定められた電波暗室等の試験設備でご使用いただく。
2. 実験局の免許を取得後ご使用いただく。
3. 技術基準適合証明を取得後ご使用いただく。

なお、本製品は、上記の「ご使用にあたっての注意」を譲渡先、移転先に通知しない限り、譲渡、移転できないものとします。

上記を遵守頂けない場合は、電波法の罰則が適用される可能性があることをご留意ください。日本テキサス・インスツルメンツ株式会社

東京都新宿区西新宿 6 丁目 2 4 番 1 号
西新宿三井ビル

3.3.3 *Notice for EVMs for Power Line Communication:* Please see http://www.tij.co.jp/llds/ti_ja/general/eStore/notice_02.page
電力線搬送波通信についての開発キットをお使いになる際の注意事項については、次のところをご覧ください。 http://www.tij.co.jp/llds/ti_ja/general/eStore/notice_02.page

3.4 *European Union*

3.4.1 *For EVMs subject to EU Directive 2014/30/EU (Electromagnetic Compatibility Directive):*

This is a class A product intended for use in environments other than domestic environments that are connected to a low-voltage power-supply network that supplies buildings used for domestic purposes. In a domestic environment this product may cause radio interference in which case the user may be required to take adequate measures.

4 *EVM Use Restrictions and Warnings:*

4.1 EVMS ARE NOT FOR USE IN FUNCTIONAL SAFETY AND/OR SAFETY CRITICAL EVALUATIONS, INCLUDING BUT NOT LIMITED TO EVALUATIONS OF LIFE SUPPORT APPLICATIONS.

4.2 User must read and apply the user guide and other available documentation provided by TI regarding the EVM prior to handling or using the EVM, including without limitation any warning or restriction notices. The notices contain important safety information related to, for example, temperatures and voltages.

4.3 *Safety-Related Warnings and Restrictions:*

4.3.1 User shall operate the EVM within TI's recommended specifications and environmental considerations stated in the user guide, other available documentation provided by TI, and any other applicable requirements and employ reasonable and customary safeguards. Exceeding the specified performance ratings and specifications (including but not limited to input and output voltage, current, power, and environmental ranges) for the EVM may cause personal injury or death, or property damage. If there are questions concerning performance ratings and specifications, User should contact a TI field representative prior to connecting interface electronics including input power and intended loads. Any loads applied outside of the specified output range may also result in unintended and/or inaccurate operation and/or possible permanent damage to the EVM and/or interface electronics. Please consult the EVM user guide prior to connecting any load to the EVM output. If there is uncertainty as to the load specification, please contact a TI field representative. During normal operation, even with the inputs and outputs kept within the specified allowable ranges, some circuit components may have elevated case temperatures. These components include but are not limited to linear regulators, switching transistors, pass transistors, current sense resistors, and heat sinks, which can be identified using the information in the associated documentation. When working with the EVM, please be aware that the EVM may become very warm.

4.3.2 EVMs are intended solely for use by technically qualified, professional electronics experts who are familiar with the dangers and application risks associated with handling electrical mechanical components, systems, and subsystems. User assumes all responsibility and liability for proper and safe handling and use of the EVM by User or its employees, affiliates, contractors or designees. User assumes all responsibility and liability to ensure that any interfaces (electronic and/or mechanical) between the EVM and any human body are designed with suitable isolation and means to safely limit accessible leakage currents to minimize the risk of electrical shock hazard. User assumes all responsibility and liability for any improper or unsafe handling or use of the EVM by User or its employees, affiliates, contractors or designees.

4.4 User assumes all responsibility and liability to determine whether the EVM is subject to any applicable international, federal, state, or local laws and regulations related to User's handling and use of the EVM and, if applicable, User assumes all responsibility and liability for compliance in all respects with such laws and regulations. User assumes all responsibility and liability for proper disposal and recycling of the EVM consistent with all applicable international, federal, state, and local requirements.

5. *Accuracy of Information:* To the extent TI provides information on the availability and function of EVMs, TI attempts to be as accurate as possible. However, TI does not warrant the accuracy of EVM descriptions, EVM availability or other information on its websites as accurate, complete, reliable, current, or error-free.

6. *Disclaimers:*
- 6.1 EXCEPT AS SET FORTH ABOVE, EVMS AND ANY MATERIALS PROVIDED WITH THE EVM (INCLUDING, BUT NOT LIMITED TO, REFERENCE DESIGNS AND THE DESIGN OF THE EVM ITSELF) ARE PROVIDED "AS IS" AND "WITH ALL FAULTS." TI DISCLAIMS ALL OTHER WARRANTIES, EXPRESS OR IMPLIED, REGARDING SUCH ITEMS, INCLUDING BUT NOT LIMITED TO ANY EPIDEMIC FAILURE WARRANTY OR IMPLIED WARRANTIES OF MERCHANTABILITY OR FITNESS FOR A PARTICULAR PURPOSE OR NON-INFRINGEMENT OF ANY THIRD PARTY PATENTS, COPYRIGHTS, TRADE SECRETS OR OTHER INTELLECTUAL PROPERTY RIGHTS.
- 6.2 EXCEPT FOR THE LIMITED RIGHT TO USE THE EVM SET FORTH HEREIN, NOTHING IN THESE TERMS SHALL BE CONSTRUED AS GRANTING OR CONFERRING ANY RIGHTS BY LICENSE, PATENT, OR ANY OTHER INDUSTRIAL OR INTELLECTUAL PROPERTY RIGHT OF TI, ITS SUPPLIERS/LICENSORS OR ANY OTHER THIRD PARTY, TO USE THE EVM IN ANY FINISHED END-USER OR READY-TO-USE FINAL PRODUCT, OR FOR ANY INVENTION, DISCOVERY OR IMPROVEMENT, REGARDLESS OF WHEN MADE, CONCEIVED OR ACQUIRED.
7. *USER'S INDEMNITY OBLIGATIONS AND REPRESENTATIONS.* USER WILL DEFEND, INDEMNIFY AND HOLD TI, ITS LICENSORS AND THEIR REPRESENTATIVES HARMLESS FROM AND AGAINST ANY AND ALL CLAIMS, DAMAGES, LOSSES, EXPENSES, COSTS AND LIABILITIES (COLLECTIVELY, "CLAIMS") ARISING OUT OF OR IN CONNECTION WITH ANY HANDLING OR USE OF THE EVM THAT IS NOT IN ACCORDANCE WITH THESE TERMS. THIS OBLIGATION SHALL APPLY WHETHER CLAIMS ARISE UNDER STATUTE, REGULATION, OR THE LAW OF TORT, CONTRACT OR ANY OTHER LEGAL THEORY, AND EVEN IF THE EVM FAILS TO PERFORM AS DESCRIBED OR EXPECTED.
8. *Limitations on Damages and Liability:*
- 8.1 *General Limitations.* IN NO EVENT SHALL TI BE LIABLE FOR ANY SPECIAL, COLLATERAL, INDIRECT, PUNITIVE, INCIDENTAL, CONSEQUENTIAL, OR EXEMPLARY DAMAGES IN CONNECTION WITH OR ARISING OUT OF THESE TERMS OR THE USE OF THE EVMS , REGARDLESS OF WHETHER TI HAS BEEN ADVISED OF THE POSSIBILITY OF SUCH DAMAGES. EXCLUDED DAMAGES INCLUDE, BUT ARE NOT LIMITED TO, COST OF REMOVAL OR REINSTALLATION, ANCILLARY COSTS TO THE PROCUREMENT OF SUBSTITUTE GOODS OR SERVICES, RETESTING, OUTSIDE COMPUTER TIME, LABOR COSTS, LOSS OF GOODWILL, LOSS OF PROFITS, LOSS OF SAVINGS, LOSS OF USE, LOSS OF DATA, OR BUSINESS INTERRUPTION. NO CLAIM, SUIT OR ACTION SHALL BE BROUGHT AGAINST TI MORE THAN TWELVE (12) MONTHS AFTER THE EVENT THAT GAVE RISE TO THE CAUSE OF ACTION HAS OCCURRED.
- 8.2 *Specific Limitations.* IN NO EVENT SHALL TI'S AGGREGATE LIABILITY FROM ANY USE OF AN EVM PROVIDED HEREUNDER, INCLUDING FROM ANY WARRANTY, INDEMNITY OR OTHER OBLIGATION ARISING OUT OF OR IN CONNECTION WITH THESE TERMS, , EXCEED THE TOTAL AMOUNT PAID TO TI BY USER FOR THE PARTICULAR EVM(S) AT ISSUE DURING THE PRIOR TWELVE (12) MONTHS WITH RESPECT TO WHICH LOSSES OR DAMAGES ARE CLAIMED. THE EXISTENCE OF MORE THAN ONE CLAIM SHALL NOT ENLARGE OR EXTEND THIS LIMIT.
9. *Return Policy.* Except as otherwise provided, TI does not offer any refunds, returns, or exchanges. Furthermore, no return of EVM(s) will be accepted if the package has been opened and no return of the EVM(s) will be accepted if they are damaged or otherwise not in a resalable condition. If User feels it has been incorrectly charged for the EVM(s) it ordered or that delivery violates the applicable order, User should contact TI. All refunds will be made in full within thirty (30) working days from the return of the components(s), excluding any postage or packaging costs.
10. *Governing Law:* These terms and conditions shall be governed by and interpreted in accordance with the laws of the State of Texas, without reference to conflict-of-laws principles. User agrees that non-exclusive jurisdiction for any dispute arising out of or relating to these terms and conditions lies within courts located in the State of Texas and consents to venue in Dallas County, Texas. Notwithstanding the foregoing, any judgment may be enforced in any United States or foreign court, and TI may seek injunctive relief in any United States or foreign court.

IMPORTANT NOTICE FOR TI DESIGN INFORMATION AND RESOURCES

Texas Instruments Incorporated ("TI") technical, application or other design advice, services or information, including, but not limited to, reference designs and materials relating to evaluation modules, (collectively, "TI Resources") are intended to assist designers who are developing applications that incorporate TI products; by downloading, accessing or using any particular TI Resource in any way, you (individually or, if you are acting on behalf of a company, your company) agree to use it solely for this purpose and subject to the terms of this Notice.

TI's provision of TI Resources does not expand or otherwise alter TI's applicable published warranties or warranty disclaimers for TI products, and no additional obligations or liabilities arise from TI providing such TI Resources. TI reserves the right to make corrections, enhancements, improvements and other changes to its TI Resources.

You understand and agree that you remain responsible for using your independent analysis, evaluation and judgment in designing your applications and that you have full and exclusive responsibility to assure the safety of your applications and compliance of your applications (and of all TI products used in or for your applications) with all applicable regulations, laws and other applicable requirements. You represent that, with respect to your applications, you have all the necessary expertise to create and implement safeguards that (1) anticipate dangerous consequences of failures, (2) monitor failures and their consequences, and (3) lessen the likelihood of failures that might cause harm and take appropriate actions. You agree that prior to using or distributing any applications that include TI products, you will thoroughly test such applications and the functionality of such TI products as used in such applications. TI has not conducted any testing other than that specifically described in the published documentation for a particular TI Resource.

You are authorized to use, copy and modify any individual TI Resource only in connection with the development of applications that include the TI product(s) identified in such TI Resource. NO OTHER LICENSE, EXPRESS OR IMPLIED, BY ESTOPPEL OR OTHERWISE TO ANY OTHER TI INTELLECTUAL PROPERTY RIGHT, AND NO LICENSE TO ANY TECHNOLOGY OR INTELLECTUAL PROPERTY RIGHT OF TI OR ANY THIRD PARTY IS GRANTED HEREIN, including but not limited to any patent right, copyright, mask work right, or other intellectual property right relating to any combination, machine, or process in which TI products or services are used. Information regarding or referencing third-party products or services does not constitute a license to use such products or services, or a warranty or endorsement thereof. Use of TI Resources may require a license from a third party under the patents or other intellectual property of the third party, or a license from TI under the patents or other intellectual property of TI.

TI RESOURCES ARE PROVIDED "AS IS" AND WITH ALL FAULTS. TI DISCLAIMS ALL OTHER WARRANTIES OR REPRESENTATIONS, EXPRESS OR IMPLIED, REGARDING TI RESOURCES OR USE THEREOF, INCLUDING BUT NOT LIMITED TO ACCURACY OR COMPLETENESS, TITLE, ANY EPIDEMIC FAILURE WARRANTY AND ANY IMPLIED WARRANTIES OF MERCHANTABILITY, FITNESS FOR A PARTICULAR PURPOSE, AND NON-INFRINGEMENT OF ANY THIRD PARTY INTELLECTUAL PROPERTY RIGHTS.

TI SHALL NOT BE LIABLE FOR AND SHALL NOT DEFEND OR INDEMNIFY YOU AGAINST ANY CLAIM, INCLUDING BUT NOT LIMITED TO ANY INFRINGEMENT CLAIM THAT RELATES TO OR IS BASED ON ANY COMBINATION OF PRODUCTS EVEN IF DESCRIBED IN TI RESOURCES OR OTHERWISE. IN NO EVENT SHALL TI BE LIABLE FOR ANY ACTUAL, DIRECT, SPECIAL, COLLATERAL, INDIRECT, PUNITIVE, INCIDENTAL, CONSEQUENTIAL OR EXEMPLARY DAMAGES IN CONNECTION WITH OR ARISING OUT OF TI RESOURCES OR USE THEREOF, AND REGARDLESS OF WHETHER TI HAS BEEN ADVISED OF THE POSSIBILITY OF SUCH DAMAGES.

You agree to fully indemnify TI and its representatives against any damages, costs, losses, and/or liabilities arising out of your non-compliance with the terms and provisions of this Notice.

This Notice applies to TI Resources. Additional terms apply to the use and purchase of certain types of materials, TI products and services. These include; without limitation, TI's standard terms for semiconductor products (<http://www.ti.com/sc/docs/stdterms.htm>), [evaluation modules](#), and [samples](http://www.ti.com/sc/docs/sampterm.htm) (<http://www.ti.com/sc/docs/sampterm.htm>).

Mailing Address: Texas Instruments, Post Office Box 655303, Dallas, Texas 75265
Copyright © 2017, Texas Instruments Incorporated