

# Eveready Carbon Zinc Battery

## Handbook and Application Manual

Energizer Brands, LLC. | 800-383-7323 | [www.energizer.com](http://www.energizer.com)

## *Eveready Carbon Zinc (Zn/ MnO<sub>2</sub>)* Application Manual

Eveready Carbon Zinc batteries are marketed in three basic grades—General Purpose, Heavy Duty and Super Heavy Duty. Super Heavy Duty is the premium Carbon Zinc, which performs better on moderate to heavy drains or continuous drains versus the Heavy Duty and General Purpose grades.

Carbon Zinc batteries come in two electrochemical systems: the LeClanche and Zinc Chloride. Most cylindrical Eveready Carbon Zinc batteries are constructed using the Zinc Chloride system with two different sealing and jacket constructions namely: Paper Jacket and Metal Jacket. Only a few flat cell or higher voltage carbon zinc multi-batteries such as those used for 9V batteries currently utilize LeClanche system.

Eveready Battery Company has aggressively pursued the reduction of heavy metals in all Carbon Zinc batteries. All Eveready carbon zinc batteries have no added mercury or cadmium.

### **System Description:**

**Carbon Zinc:** A generic term for primary dry batteries of Zinc Chloride system. This battery has an anode of zinc, a cathode of manganese dioxide, and a slightly acidic electrolyte.

**LeClanche:** A Carbon Zinc battery with a slightly acidic electrolyte consisting of ammonium chloride and zinc chloride in water.

**Zinc Chloride:** A Carbon Zinc battery with a slightly acidic electrolyte consisting mainly of zinc chloride in water.

Carbon Zinc batteries provide an economical power source for devices requiring light to moderate drain because of the use of inexpensive materials and their time proven constructions. All Eveready carbon zinc cells are primary batteries and therefore are not designed for recharging.

The service capacity of a Carbon Zinc battery is not a fixed number of ampere hours because the battery functions at different efficiencies depending upon the conditions imposed upon it. The service varies with current drain, operating schedule, and cutoff voltage. The battery is also affected by the operating temperature and storage conditions.

# Eveready Carbon Zinc Battery

## Handbook and Application Manual

Energizer Brands, LLC. | 800-383-7323 | [www.energizer.com](http://www.energizer.com)

The general characteristics of an Eveready Battery Company Zinc Chloride battery are:

- Less expensive than alkaline. Economical in terms of cost per hour on moderate current drains or use frequency.
- Less output capacity decrease than LeClanche as the drain rate increases.
- Less sensitive than LeClanche to changes in the discharge rate and/or duty cycle.
- Lower internal resistance than LeClanche.
- Better low temperature performance than LeClanche.
- Energy density of approximately 2 to 2.5 watt hours per cubic inch.
- Average service maintenance exceeds 90% after one year storage at 21°C on typical tests.
- Higher open circuit and initial closed circuit voltage than LeClanche or alkaline.
- Lower unit weight than alkaline.
- Available in voltages ranging from 1.5 volts to 12 volts and in a variety of shapes and sizes.
- Sloping discharge curve.

### **Battery Construction:**

The carbon zinc battery uses a zinc anode, a manganese dioxide cathode, and an electrolyte of zinc chloride dissolved in water. Powdered carbon is used in the cathode mix, usually in the form of carbon black to improve conductivity of the mix and for moisture retention.

Carbon zinc batteries are produced in two general configurations:

- Cylindrical--available as unit cells or in assembled multi-cell batteries
- Flat--available in multi-cell batteries only

Within the carbon zinc cylindrical battery category are two constructions: Paper Jacket and Metal Jacket. The Zinc Chloride battery contains proportionately zinc chloride in the electrolyte and therefore requires different battery design as shown in the following diagram:

# Eveready Carbon Zinc Battery

## Handbook and Application Manual

Energizer Brands, LLC. | 800-383-7323 | [www.energizer.com](http://www.energizer.com)

### PAPER JACKET CONSTRUCTION

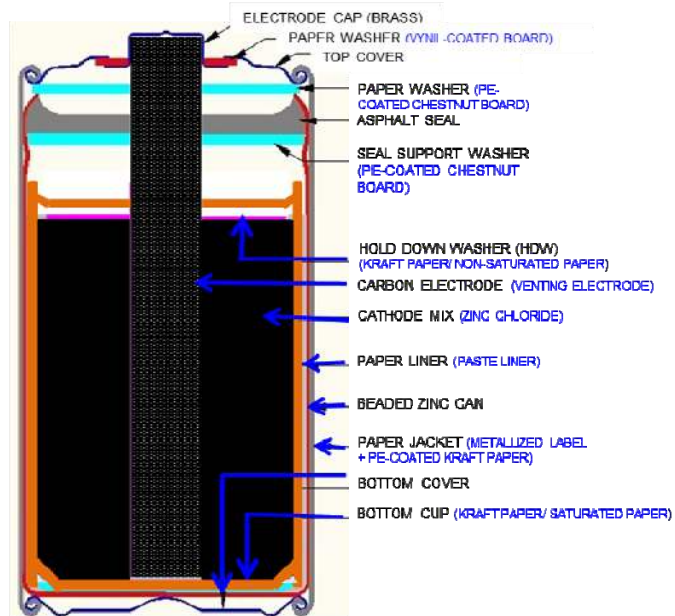

### METAL JACKET CONSTRUCTION

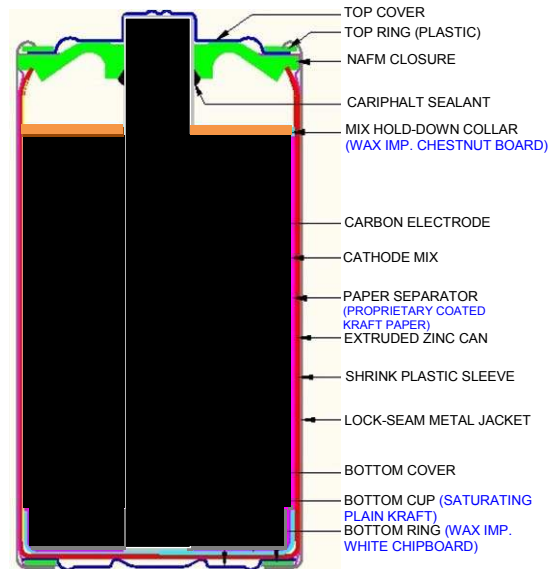

# Eveready Carbon Zinc Battery

## Handbook and Application Manual

Energizer Brands, LLC. | 800-383-7323 | [www.energizer.com](http://www.energizer.com)

**Cathodes** are a mixture of manganese dioxide, carbon conductor and electrolyte.

**Anodes** are zinc alloy can. The can also confines the active materials in the battery.

**Separators** are coated paper selected to prevent migration of solid particles in the battery.

**Carbon electrode** serves as the cathode current collector.

**Top and bottom covers** provide contact surfaces of plated steel.

**The outside** of the battery is either covered with plastic film and metal jacket or Kraft paper and a printed paper label.

**Asphalt or plastic seal** acts as the battery seal.

Flat cells used in the construction of 9 volt batteries are of the LeClanche system. The flat cell contains no voids or carbon rod as does the cylindrical battery. The flat cell, because of its rectangular form, reduces wasted space in assembled batteries. The energy to volume ratio of a multi-cell battery utilizing cylindrical cells is decreased by the voids occurring between the cells. These two factors account for substantially higher energy volume ratio for flat cell batteries when compared to batteries consisting of cylindrical cells. The cutaway of a typical Eveready flat cell battery is shown here:

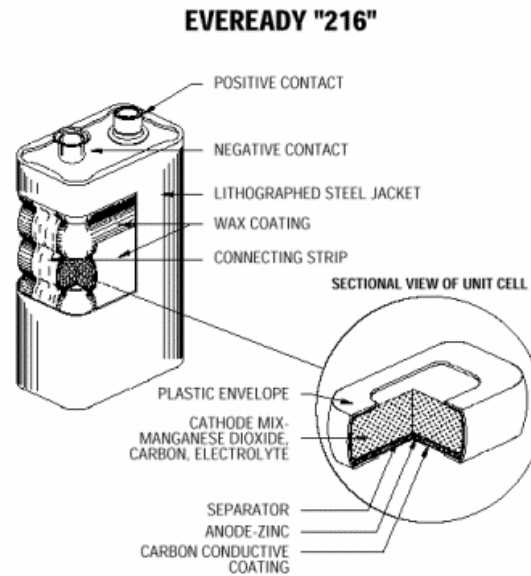

### Typical Eveready Flat Cell LeClanche Components

- Cathodes are a mixture of manganese dioxide, carbon conductor and electrolyte.
- Anodes are zinc alloy sheets.
- Separators are specially selected to prevent migration of solid particles in the cell.
- Plastic envelope confines active cell materials.
- Carbon conductive coating on the zinc anode serves as the cathode collector for the adjacent cell.
- Wax coating provides the battery seal.

# Eveready Carbon Zinc Battery

## Handbook and Application Manual

Energizer Brands, LLC. | 800-383-7323 | [www.energizer.com](http://www.energizer.com)

- Connector strips connect the flat cell stack to the battery terminals.
- Lithographed steel jacket is electrically insulated from battery components.
- Specialized terminals provide positive and negative external contact surfaces.

### Electro-Chemistry:

#### LeClanche

The performance of a LeClanche battery is the result of an electrochemical reaction between:

A cathode composed of carbon and refined manganese dioxide which may contain some naturally occurring manganese dioxide. The more pure the cathode material, the better the performance. (The carbon component of the cathode is usually carbon black and provides increased conductivity and moisture retention.)

An anode of high purity zinc alloy.

A highly conductive, slightly acidic, electrolyte solution of ammonium chloride and zinc chloride in water.

The chemical equation for this reaction is:

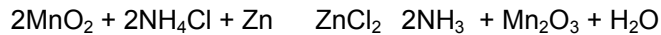

#### Zinc Chloride

The performance of a Zinc Chloride battery is the result of an electrochemical reaction between:

A cathode composed of carbon and refined manganese dioxide which may contain some naturally occurring manganese dioxide.

- a. The carbon component of the cathode is usually carbon black and provides increased conductivity and moisture retention.
- b. Typically, Zinc Chloride batteries have a higher proportion of carbon to manganese dioxide than LeClanche.

An anode of high purity zinc alloy.

A highly conductive, slightly acidic, electrolyte solution of zinc chloride in water which may contain a small amount of ammonium chloride.

- a. A Zinc Chloride battery contains a greater volume of electrolyte than the same size LeClanche battery.
- b. The electrolyte is slightly more acidic than a LeClanche electrolyte.

The chemical equation of this reaction is:

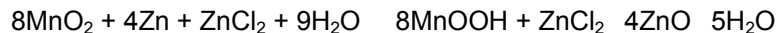

# Eveready Carbon Zinc Battery

## Handbook and Application Manual

Energizer Brands, LLC. | 800-383-7323 | [www.energizer.com](http://www.energizer.com)

A Zinc Chloride battery is typically over 1.60 volts. The closed circuit voltage declines gradually as a function of the depth of discharge. The energy output of Zinc Chloride batteries is less sensitive to variations in the discharge current and duty cycle than comparable size LeClanche batteries. Typical D size performance to a 0.75 volt cutoff is shown in the following diagrams:

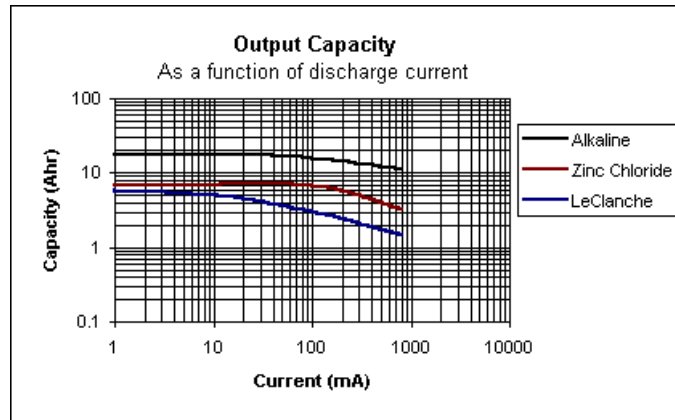

The efficiency of a carbon zinc or alkaline battery improves as the current drain decreases as seen in the above graph. As a result, an important application guide-line should be considered: "For increased efficiency, use as large a battery as possible, consistent with the physical limitations of the device." This has the same effect as lowering the current. As an example, doubling the size of a carbon zinc battery will more than double the service life at a given drain.

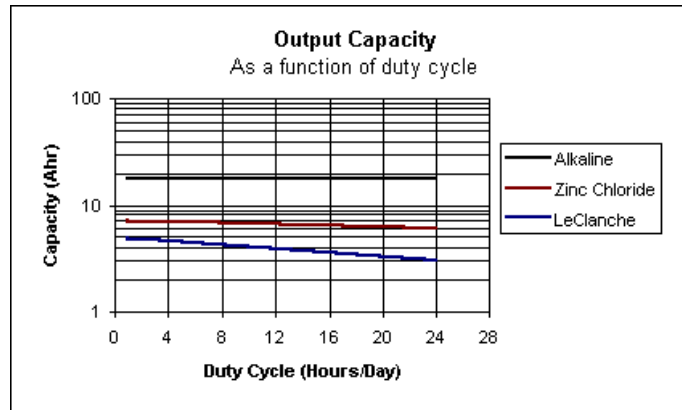

The electrochemical inputs of cylindrical D size batteries typically are in a ratio of 2:3:5 for, Zinc Chloride and Alkaline respectively. The differences in efficiency and rate sensitivity between the two systems cause variations in actual output in simulated typical applications as shown in the following table and graph:

### Eveready D Size

# Eveready Carbon Zinc Battery

## Handbook and Application Manual

Energizer Brands, LLC. | 800-383-7323 | [www.energizer.com](http://www.energizer.com)

### Typical Percent of Zinc Chloride vs Alkaline Service

Test	Load (Ohms)	Duty Cycle	Zinc Chloride	Alkaline
Motor Toy	2.2	1Hpd to 0.8 V	100%	250%
Flashlight	2.2	4 min/hr 8 hr/day to 0.9V	100%	300%
Radio	24	4 hr/day to 0.9 V	100%	260%

Carbon Zinc batteries are more efficient when used in low rate applications as shown in the curve below. Typical carbon zinc light drain is defined as a current that would discharge the battery after 50 or more hours of use at room temperature.

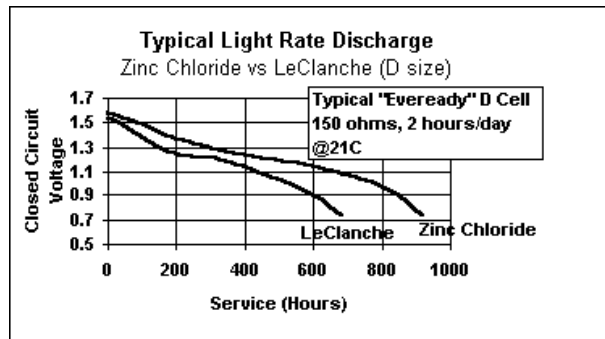

As the drain is increased, the service difference between Alkaline and Zinc Chloride systems increases. This relationship is shown by the following discharge curves. Typical carbon zinc moderate drain is defined as a current that would discharge the cell within 10-50 hours of use at room temperature.

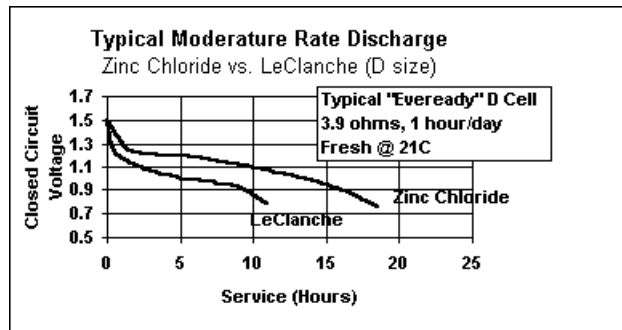

# Eveready Carbon Zinc Battery

## Handbook and Application Manual

Energizer Brands, LLC. | 800-383-7323 | [www.energizer.com](http://www.energizer.com)

### Temperature

Changes in temperature will affect the reactivity of battery chemical components. The typical effect on service of a D size cylindrical battery to a 0.75 volt cutoff is shown in the following diagram:

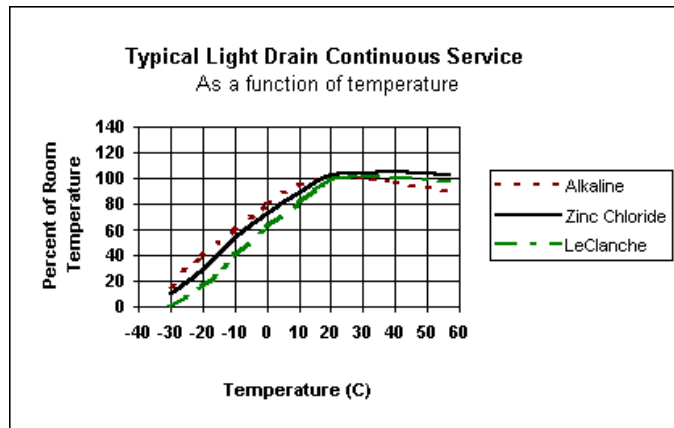

**Light Drain** is defined as a current that would discharge the battery after 50 or more hours of use at room temperature.

**Heavier Drains** at low temperature will tend to decrease the percent service from that shown in the above diagram. Zinc Chloride system is affected moderately, and Alkaline the least as the drain increases. The service on all drains at high temperatures over time is eventually reduced by an increase in self discharge.

Eveready Carbon Zinc batteries provide good service maintenance due to time tested construction, quality control of materials and close monitoring of batteries during assembly.

### Service Maintenance (storage at 21°C)

Time of Storage at 21C	Typical % of Fresh Service Retained
1 year	90 - 100%
2 years	80-90%
3 years	75-85%
4 years	65-80%

The storage of carbon zinc batteries at temperatures below 21°C will increase their service maintenance. While freezer storage (-20°C) of a carbon zinc battery is not harmful, storage at 5 to 10°C is effective. Batteries to be stored at low temperature storage should be allowed to reach room temperature in their packing so as to avoid condensations of moisture which may cause electrical leakage and/or destruction of the jackets. Storage at high temperatures exceeding 21°C for sustained periods of time will significantly reduce service maintenance. The typical effects of storage temperature on carbon zinc service maintenance are shown in the following diagram:



# Eveready Carbon Zinc Battery

## Handbook and Application Manual

Energizer Brands, LLC. | 800-383-7323 | [www.energizer.com](http://www.energizer.com)

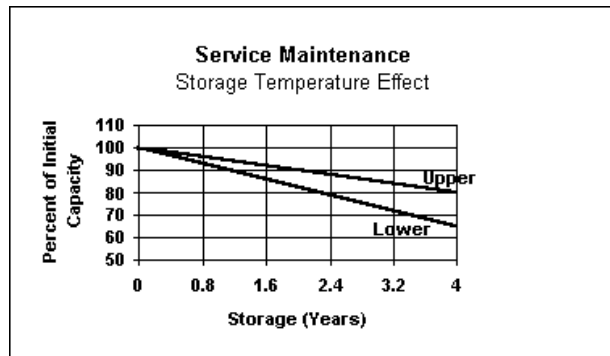

### Internal Resistance:

The internal resistance ( $R_i$ ) of a battery is its opposition to the flow of current. In all cases, this resistance increases as the temperature of a battery decreases. While the  $R_i$  will vary with load for the battery size, it will be higher for LeClanche than Zinc Chloride which in turn will also be higher than Alkaline. The  $R_i$  of a cylindrical carbon zinc battery increases gradually until it approaches the end of service life and then increases rapidly.

Internal resistance is typically measured in one of two ways:

1. As a reduction in closed circuit voltage when the applied load is increased (voltage drop method).
2. As a maximum short circuit current (flash amperage).

The voltage drop method in determining the effective internal resistance is also used by ANSI.

The  $R_i$  values obtained by either method of measurement are subject to number of variables and operator techniques. The effective  $R_i$  values shown on the data pages were calculated by the voltage drop method as this more accurately projects the batteries current carrying capability in actual device applications. This calculation involves placing a battery on a constant background load, allowing it to stabilize and then pulsing it with a heavier load for one second. The resulting voltage drop is then measured and expressed in terms of Ohms as shown in the following example.

### Determination of Internal Resistance ( $R_i$ )

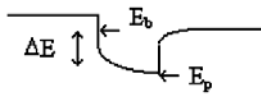

$$I_b = \frac{E_b}{R_b}$$

$$I_p = \frac{E_p}{R_p}$$

$$R_i = \frac{\Delta E}{\Delta I} = \frac{E_b - E_p}{I_p - I_b}$$

### Voltage Drop Method

$R_i$  = Internal Resistance

$R_b$  = Resistance of Background Load

# Eveready Carbon Zinc Battery

## Handbook and Application Manual

Energizer Brands, LLC. | 800-383-7323 | [www.energizer.com](http://www.energizer.com)

$E_b$  = Background Voltage  
 $R_p$  = Resistance at Pulse Load  
 $E_p$  = Voltage at end of pulse  
 $E$  = Voltage Change  
 $I$  = Current Change  
 $I_b$  = Background Current  
 $I_p$  = Current at End of Pulse

Although flash amperage does not indicate battery freshness or potential service, circuit designers should be aware of the maximum current that a battery could supply if a component failure occurs. The following are typical maximum flash amperage values for Eveready carbon zinc batteries. These flash amperage values can vary widely without affecting battery service in actual applications.

	<b>Typical Maximum Flash Amperage for CZ Zinc Chloride Battery</b>
<b>D</b>	<b>9</b>
<b>C</b>	<b>7</b>
<b>AA</b>	<b>5</b>
<b>AAA</b>	<b>3</b>
<b>9V</b>	<b>----</b>

### Applications

Eveready carbon zinc batteries will meet a wide variety of device applications utilizing light to moderate drains, such as:

- Alarm Systems
- Barricade Flashers
- Boom Boxes
- Calculators
- Clocks
- Communications equipment

# Eveready Carbon Zinc Battery

## Handbook and Application Manual

Energizer Brands, LLC. | 800-383-7323 | [www.energizer.com](http://www.energizer.com)

- Electrical fence controllers
- Electronic games
- Flashlights
- Fluorescent lanterns
- Garage door openers
- Home entertainment remote controls
- Kerosene heater igniters
- Home security devices
- Laboratory instruments
- Lanterns
- Marine depth finders
- Motion displayers
- Motor driven devices
- Penlights
- Personal care devices
- Portable tape recorders and players
- Radios
- Radio controlled toys
- Remote control transmitters
- Small lighted toys and novelties
- Smoke detectors (only when recommended by manufacturer)
- Specialty High voltage electronic photo flash
- Stereo headsets
- Test equipment
- Toys

This reference manual contains general information on all Energizer/Eveready batteries within the Carbon Zinc chemical system in production at the time of preparation of the manual. Since the

# Eveready Carbon Zinc Battery

## Handbook and Application Manual

Energizer Brands, LLC. | 800-383-7323 | [www.energizer.com](http://www.energizer.com)

characteristics of individual batteries are sometimes modified, persons and businesses that are considering the use of a particular battery should contact the nearest Energizer Sales Office for current information. None of the information in the manual constitutes a representation or warranty by Energizer Brands, LLC. concerning the specific performance or characteristics of any of the batteries or devices.