

THIS DRAWING IS UNPUBLISHED. RELEASED FOR PUBLICATION
 © COPYRIGHT - By - ALL RIGHTS RESERVED.

LOC		DIST		REVISIONS			
P	LTR	DESCRIPTION		DATE	DWN	APVD	
	B3	REVISED PER ECO-11-004587		11MAR11	RK	HMR	

SPECIFICATIONS:
 BREAK BEFORE MAKE

MATERIALS:

FRAME: STEEL,ZINC PLATE
 ACTUATOR: PBT,UL94V0, SEE P/N TABLE
 TERMINAL/FIXED CONTACT: COPPER ALLOY, AG OVER NI
 OR AU OVER NI PLATE.
 MOVING CONTACT: COPPER ALLOY, AG OVER NI
 OR AU OVER NI PLATE
 TERMINAL BOARD: PHENOLIC, UL94HB

COIL SPRING: CARBON STEEL WIRE

ELECTRICAL:

CONTACT RATING, 250MILLIAMPS @ 125V AC,
 150MILLIAMPS @ 12V DC
 CONTACT RESISTANCE, 30 MILLIOHMS MAX (INITIAL),
 60 MILLIOHMS AFTER TEST
 INSULATION RESISTANCE: 500 MEGOHMS MIN.
 DIELECTRIC STRENGTH: 500 VOLTS RMS @SEA LEVEL
 LIFE EXPECTANCY: 10,000 CYCLES MIN. NO LOAD,
 6,000 AT RATED CURRENT.

MECHANICAL:

ACTUATION FORCE, 250 +150/-100 GRAMS
 TRAVEL, .126 (3.20)

ENVIRONMENTAL:

OPERATING TEMPERATURE: -10°C TO +85°C
 STORAGE TEMPERATURE: -10°C TO +85°C
 RESISTANCE TO SOLDER HEAT, 260°C FOR 10 SEC
 PER 109-202, CONDITION B
 SOLDERABILITY PER EIA-364-56A, PROCEDURE 3,
 CONDITION B

- ALL MATERIALS AND FINISHES SHALL COMPLY WITH EU DIRECTIVE 2002/95/EC OF 27 JAN2003 (ROHS)
- ALL PERFORMANCE SPECIFICATIONS WERE TESTED IN ACCORDANCE WITH JIS-C-5441 UNLESS OTHERWISE STATED.

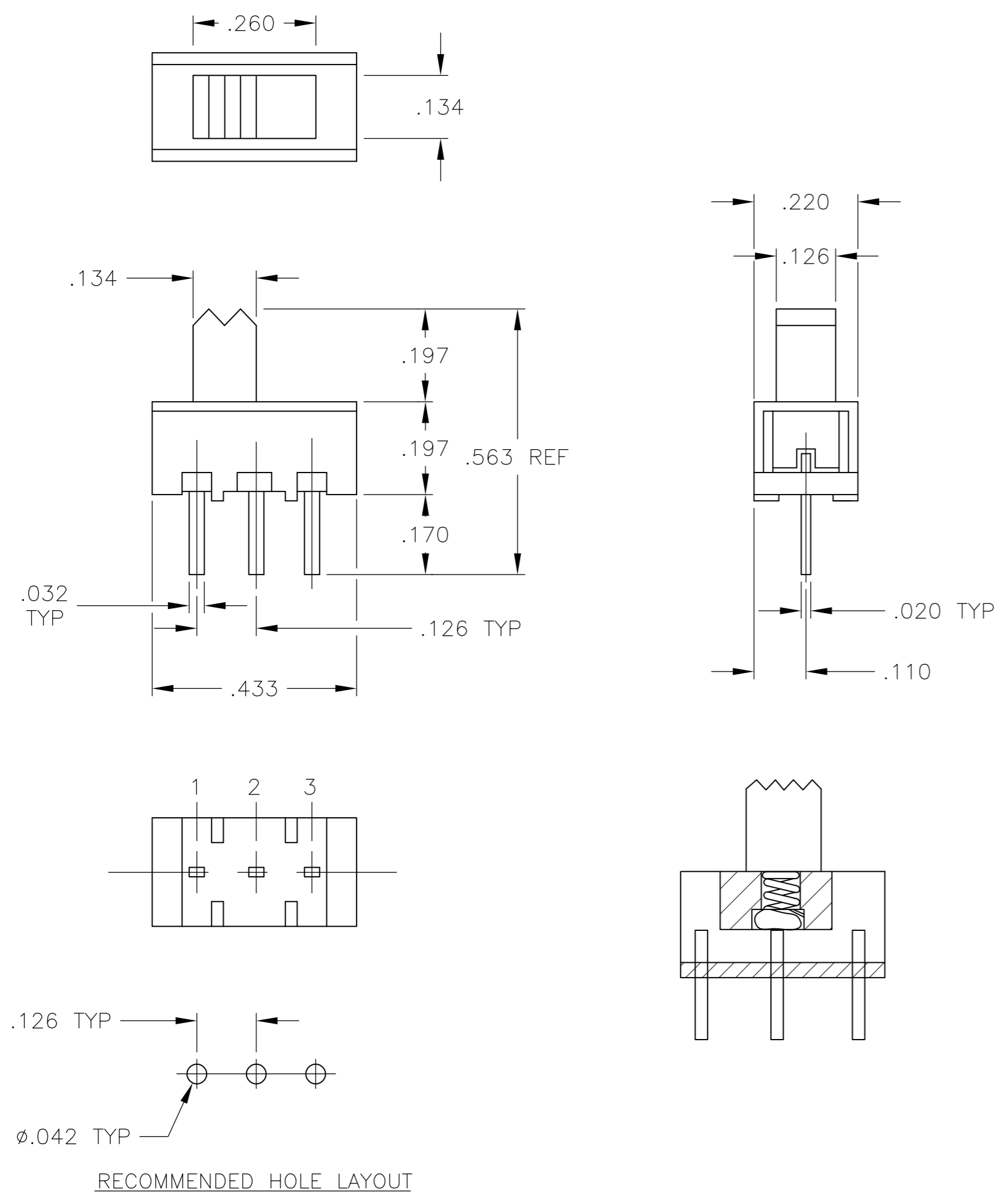

ACTUATOR POSITION	ACTUATOR COLOR	FINISH	TYPE	ALCO P/N	PART NO.
1,2	2,3	NATURAL	GOLD	SPDT	SLS121NPCG04 1825115-4
1,2	2,3	NATURAL	SILVER	SPDT	SLS121NPC04 1825115-3
1,2	2,3	BLACK	GOLD	SPDT	SLS121PCG04 1825115-2
1,2	2,3	BLACK	SILVER	SPDT	SLS121PCG04 1825115-1

THIS DRAWING IS A CONTROLLED DOCUMENT.

DWN: B S VISWESWARA 01MAR05
 CHK: M S SARVER
 APVD: -

TE Connectivity

SLIDE SWITCH, SPDT (SLS121PC & SLS121PCG)

SIZE: A2 CAGE CODE: 00779 DRAWING NO: 1825115 RESTRICTED TO: -

MATERIAL: SEE TABLE FINISH: - WEIGHT: - SCALE: 4:1 SHEET: 1 of 1 REV: B3