

SERIES AI25 EtherNet/IP®

Absolute Encoder

Key Features

- Up to 34 Bit (22 Bit ST + 12 Bit MT)
- Device Level Ring (DLR) and Address Conflict Detection (ACD)
- High Speed 10,000 RPM Continuous
- Hub Shaft and Shafted Models
- Device Data: Position, Velocity, Acceleration, Alarms
- Configuration Options: Resolution, Total Measuring Range, Preset, Direction, Scaling, Position-Velocity-Acceleration Limits

IND
Industrial Duty



EtherNet/IP®
ODVA

SPECIFICATIONS

STANDARD OPERATING CHARACTERISTICS:

Code: Absolute, Optical
Resolution Single-turn: 12 - 22 Bit
Resolution Multi-turn: 12 Bit
Linearity: ±½ LSB up to 14 Bit
Absolute Accuracy (typ.): ±35 arc-sec or ±0.01°
Repeatability (typ.): ±10 arc-sec or ±0.003°

ELECTRICAL:

Interface: EtherNet/IP
Version: Composit Test Revision CT16 Compliant
Output Code: Binary
Input Voltage: 7 - 30 VDC
Current w/o load (typ.): 24V: 60mA (ST) 70 mA (MT)
Current w/o load (max.): (ST/MT) 225 mA
Device Data: Position, Velocity, Acceleration, Alarms
Configuration Options: Resolution, Total Measuring Range, Preset, Direction, Scaling, Position-Velocity-Acceleration Limits
Request Packet Interval (RPI): 1ms
Device Level Ring: Supported
IP Address Conflict Detection: Supported
Noise Immunity: Tested to EN61326-1
Electrical Immunity: Tested to EN61326-1
Termination: Bus cover with 3x M12 connectors

MECHANICAL

Shaft Diameter: 6-12mm (solid shafts), 9.52mm – 14mm (hub shafts)
Mounting Flanges: Servo Flange, Clamping Flange, Tether Flange, Square Flange
Shaft Load (axial / radial): 40 N / 80 N
Axial/Radial Endplay of Mating Shaft (Hub Shaft only): ±1.5 mm, ±0.2 mm
Maximum Speed: 10,000 RPM (continuous duty), max. 12,000 RPM (short term)
Starting Torque (at 20 °C): typ. ≤ 0.05 Nm (lower values available upon request)
Moment of Inertia: ca. 3.8 x 10⁻⁶ kgm²
Housing Material: Aluminum or Stainless Steel
Shaft Material: Stainless Steel
Disc Material: Glass
Weight (approx.): (Aluminum) 14.8 oz. (420 g) ST/ 15.9 oz. (450 g) MT (Stainless) 2.6 lb (1180 g)

ELECTRICAL CONNECTIONS

Bus cover with 3x M12 connectors

Pin	P1	Supply voltage	P2
1	TxD+	7-30V in	TxD+
2	RxD+	N.C.	RxD+
3	TxD-	0 V in	TxD-
4	RxD-	N.C.	RxD
Shield	Shield ¹	Shield ¹	Shield ¹

¹Shield connected to encoder housing

ENVIRONMENTAL

Operating Temperature: -40 °C ... +85 °C
Storage Temperature: -40 °C ... +85 °C
Shock: 400g, 4000 m/s² (6 ms)
Vibration: 30g, 300 m/s² (10 - 2000 Hz)
Humidity: Up to 75%, (no condensation allowed)
Enclosure Rating: IP64 or IP67
General Design: As per DIN EN 61010-1, protection class III, contamination level 2, overvoltage class II

Diagnostic LED's

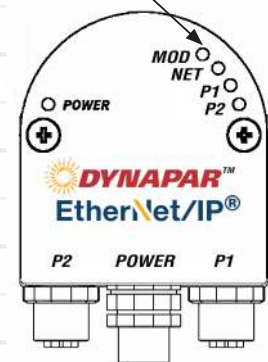



Ordering Information

To order, complete the model number with code numbers from the table below:

Code 1: Model	Code 2: Resolution	Code 3: Mounting	Code 4: Shaft Size	Code 5: Protocol	Code 6: Electrical	Code 7: Connector	Code 8: Housing
AI25	<input type="checkbox"/> <input type="checkbox"/> <input type="checkbox"/> <input type="checkbox"/>	<input type="checkbox"/>	<input type="checkbox"/>	W	2	R	<input type="checkbox"/> <input type="checkbox"/>
AI25 Size25 Absolute Encoder	0012 12 Bit ST 0013 13 Bit ST 0014 14 Bit ST 0016 16 Bit ST 0017 17 Bit ST 0018 18 Bit ST 0019 19 Bit ST 0020 20 Bit ST 0022 22 Bit ST 1212 12 Bit MT, 12 Bit ST 1213 12 Bit MT, 13 Bit ST 1214 12 Bit MT, 14 Bit ST 1216 12 Bit MT, 16 Bit ST 1217 12 Bit MT, 17 Bit ST 1218 12 Bit MT, 18 Bit ST 1219 12 Bit MT, 19 Bit ST 1220 12 Bit MT, 20 Bit ST 1222 12 Bit MT, 22 Bit ST	Available when Code 4 is 0 or A 0 Servo* Available when Code 4 is 1, 2, 8, 9 or B, C, H and J 1 Clamping* Available when Code 4 is 1,2 or B, C 2 Square Flange** Available when Code 4 is 3, 4, 5, 6, 7 or E 3 Hubshaft w/ Tether† * 58mm Dia. ** 2.5" Square † 63mm BC	w/o Shaft Seal (IP64) 0 6 mm 1 3/8" 2 10 mm 3 3/8" Hubshaft 4 12 mm Hubshaft 5 1/2" Hubshaft 6 10 mm Hubshaft 7 14 mm Hubshaft†† 8 12 mm†† 9 8 mm†† w/ Shaft Seal (IP67) A 6 mm B 3/8" C 10 mm E 12 mm Hubshaft H 12 mm†† J 8 mm†† †† Available only upon request	W EtherNet/IP	2 7-30 VDC	R Bus Cover with 3 M12 Connectors (1x Male + 2x Female)	Available when Code 3 is 2 and Code 4 is B or C Blank Aluminum SS Stainless Steel

M12 CABLE ASSEMBLIES

Part Number	Application	Description	Standard Lengths (m)
608555-XXXX	Encoder Communication w/ RJ45 Termination	M12 Male to RJ45	1,2,5, 10 ,20,30,50,100
608556-XXXX	Encoder Power Input	M12 Female to Flying Leads	1,2,5, 10 ,20,30,50,100
608557-XXXX	Encoder Daisy Chaining/Networking	M12 Male to M12 Male	1,2,5,10,20,30,50,100
608600-XXXX	Encoder Communication w/ Flying Lead Termination	M12 Male to Flying Leads	1,2,5,10,20,30,50,100

Note:

10 meter cable will be -0010

Lengths in **bold** are preferred lengths with shortest lead times.

SERIES AI25 EtherNet/IP®

DIMENSIONS in mm

Clamping Flange - Aluminum

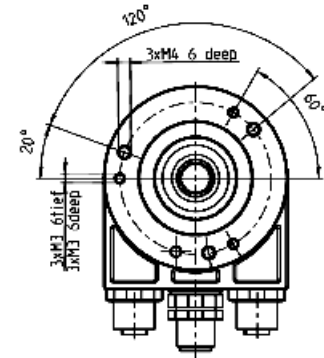
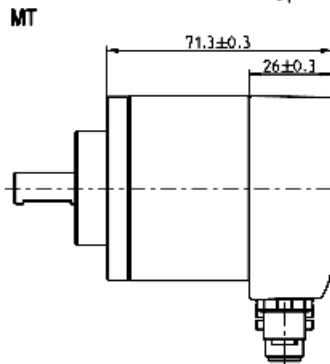
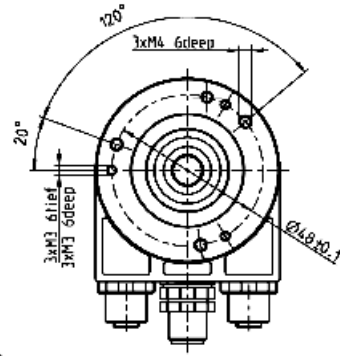
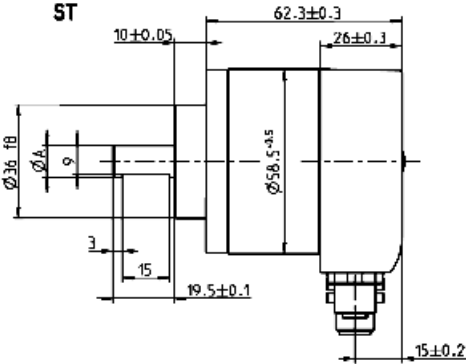
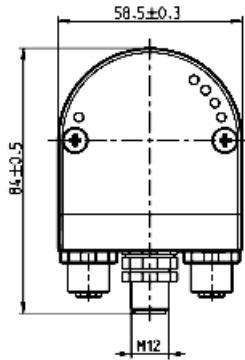

	Dimension (mm)	
Shaft - $\varnothing A$	10 ^{-0.01/-0.02}	9.52 ^{-0.01/-0.02}
Shaft Code	2 or C	1 or B

Servo Flange - Aluminum

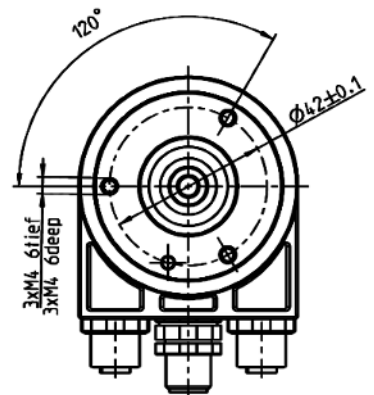
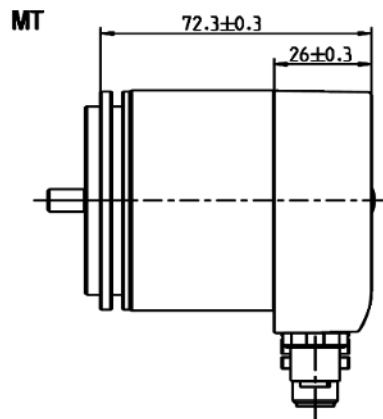
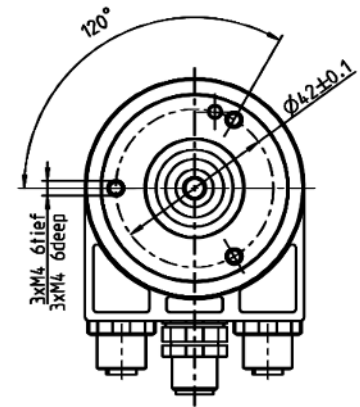
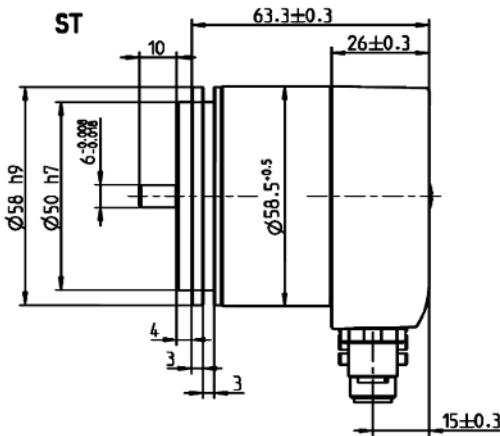
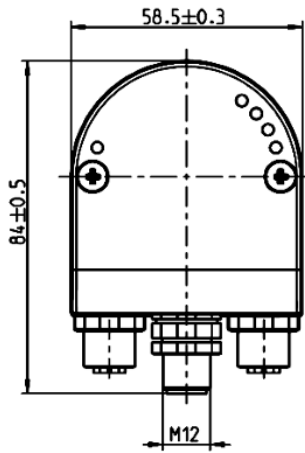

SERIES AI25 EtherNet/IP®

DIMENSIONS in mm
Hub Shaft - Aluminum

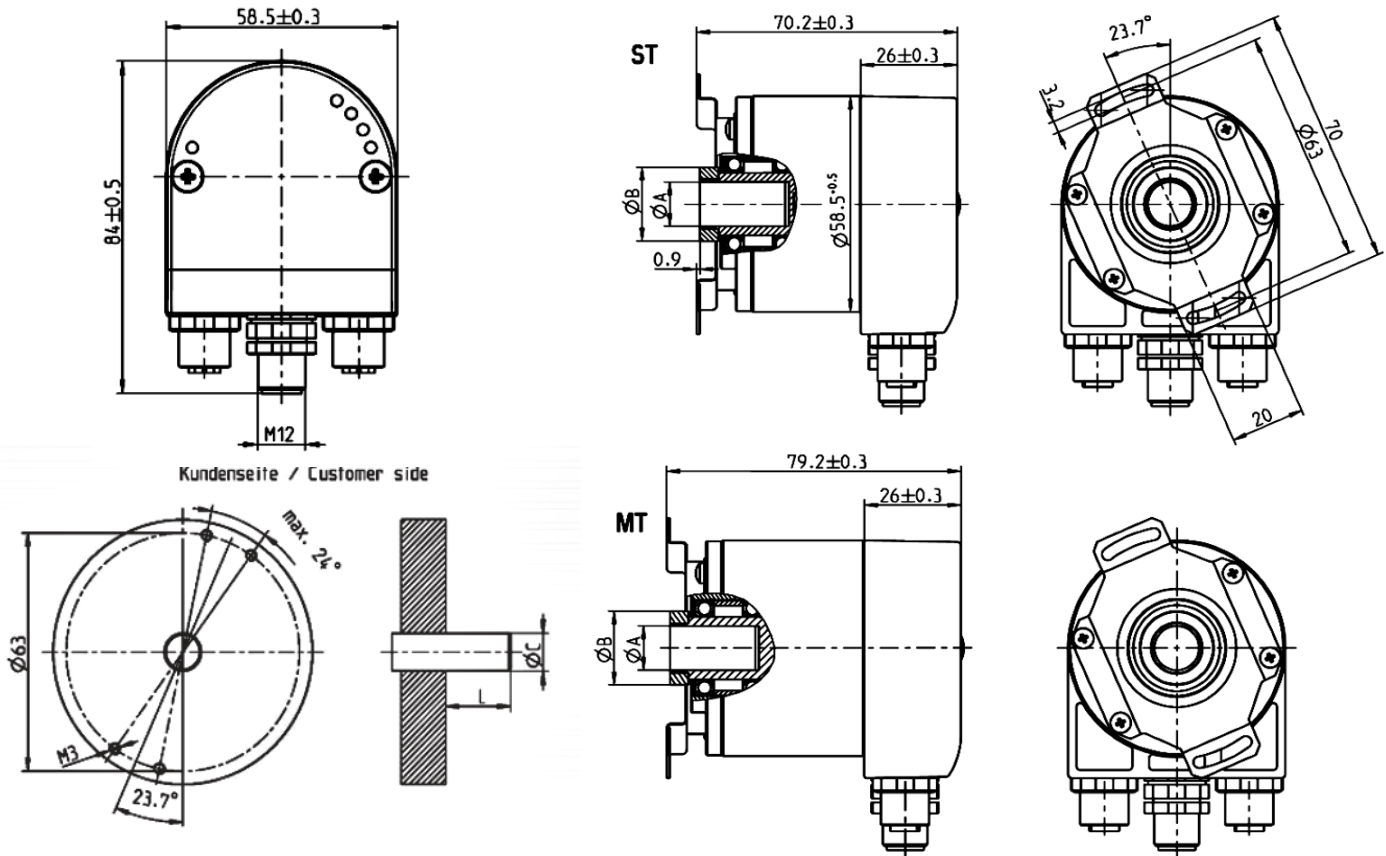

	Dimension (mm)			
Hub Shaft - ϕA	9.52 $-0.00/+0.02$	10 $-0.00/+0.02$	12 $-0.00/+0.02$	12.7 $-0.00/+0.02$
Connecting Shaft - ϕC	9.52 g7	10 g7	12 g7	12.7 g7
Clamping Ring - ϕB	18	18	20	22
Min. Engagement Length	15	15	18	18
Max. Engagement Length	20	20	20	20
Shaft Code	3 or B	2 or C	4 or E	5



SERIES AI25 EtherNet/IP®

DIMENSIONS in mm Square Flange - Aluminum

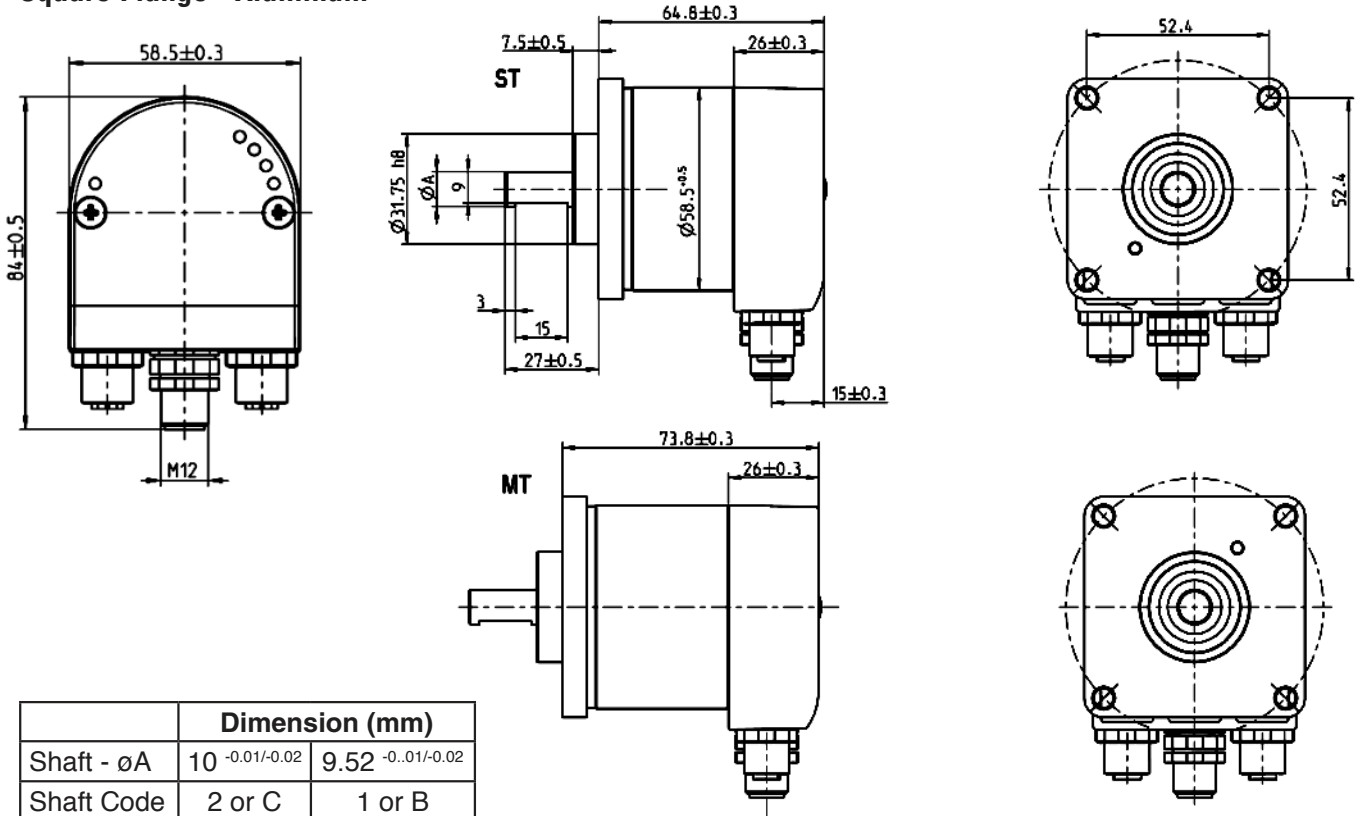

Square Flange - Stainless Steel

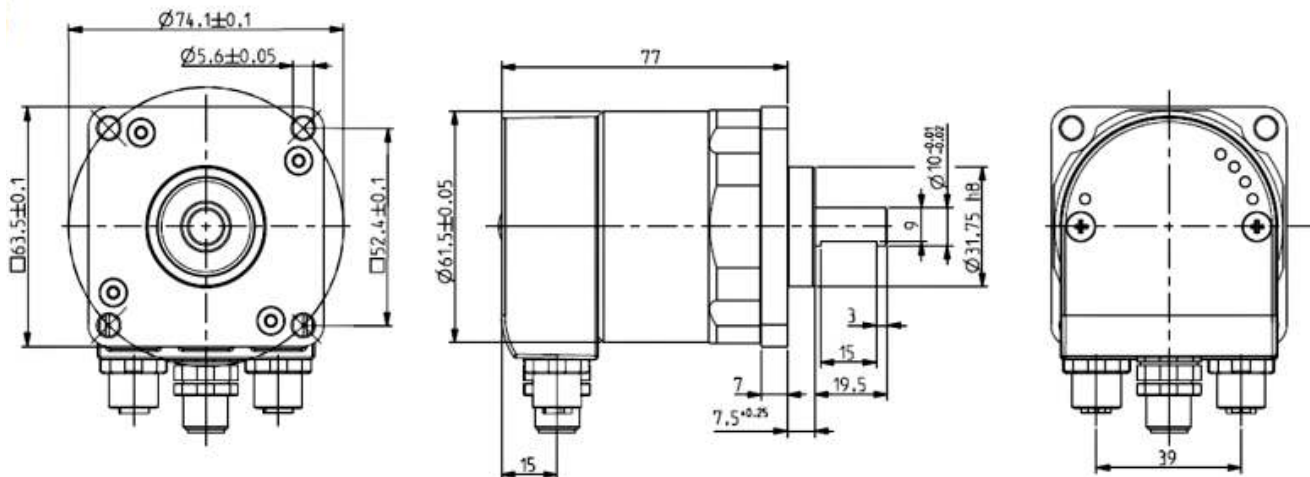

Headquarters: 1675 Delany Road • Gurnee, IL 60031-1282 • USA

Customer Service:
Tel.: +1.800.873.8731
Fax: +1.847.662.4150
custserv@dynapar.com

Technical Support
Tel.: +1.800.234.8731
Fax: +1.847.662.4150
dynapar.techsupport@dynapar.com

European Sales Representative
Hengstler GmbH
Uhlandstrasse 49, 78554 Aldingen
Germany
www.hengstler.com