

To our customers,

Old Company Name in Catalogs and Other Documents

On April 1st, 2010, NEC Electronics Corporation merged with Renesas Technology Corporation, and Renesas Electronics Corporation took over all the business of both companies. Therefore, although the old company name remains in this document, it is a valid Renesas Electronics document. We appreciate your understanding.

Renesas Electronics website: <http://www.renesas.com>

April 1st, 2010
Renesas Electronics Corporation

Issued by: Renesas Electronics Corporation (<http://www.renesas.com>)

Send any inquiries to <http://www.renesas.com/inquiry>.

Notice

1. All information included in this document is current as of the date this document is issued. Such information, however, is subject to change without any prior notice. Before purchasing or using any Renesas Electronics products listed herein, please confirm the latest product information with a Renesas Electronics sales office. Also, please pay regular and careful attention to additional and different information to be disclosed by Renesas Electronics such as that disclosed through our website.
2. Renesas Electronics does not assume any liability for infringement of patents, copyrights, or other intellectual property rights of third parties by or arising from the use of Renesas Electronics products or technical information described in this document. No license, express, implied or otherwise, is granted hereby under any patents, copyrights or other intellectual property rights of Renesas Electronics or others.
3. You should not alter, modify, copy, or otherwise misappropriate any Renesas Electronics product, whether in whole or in part.
4. Descriptions of circuits, software and other related information in this document are provided only to illustrate the operation of semiconductor products and application examples. You are fully responsible for the incorporation of these circuits, software, and information in the design of your equipment. Renesas Electronics assumes no responsibility for any losses incurred by you or third parties arising from the use of these circuits, software, or information.
5. When exporting the products or technology described in this document, you should comply with the applicable export control laws and regulations and follow the procedures required by such laws and regulations. You should not use Renesas Electronics products or the technology described in this document for any purpose relating to military applications or use by the military, including but not limited to the development of weapons of mass destruction. Renesas Electronics products and technology may not be used for or incorporated into any products or systems whose manufacture, use, or sale is prohibited under any applicable domestic or foreign laws or regulations.
6. Renesas Electronics has used reasonable care in preparing the information included in this document, but Renesas Electronics does not warrant that such information is error free. Renesas Electronics assumes no liability whatsoever for any damages incurred by you resulting from errors in or omissions from the information included herein.
7. Renesas Electronics products are classified according to the following three quality grades: "Standard", "High Quality", and "Specific". The recommended applications for each Renesas Electronics product depends on the product's quality grade, as indicated below. You must check the quality grade of each Renesas Electronics product before using it in a particular application. You may not use any Renesas Electronics product for any application categorized as "Specific" without the prior written consent of Renesas Electronics. Further, you may not use any Renesas Electronics product for any application for which it is not intended without the prior written consent of Renesas Electronics. Renesas Electronics shall not be in any way liable for any damages or losses incurred by you or third parties arising from the use of any Renesas Electronics product for an application categorized as "Specific" or for which the product is not intended where you have failed to obtain the prior written consent of Renesas Electronics. The quality grade of each Renesas Electronics product is "Standard" unless otherwise expressly specified in a Renesas Electronics data sheets or data books, etc.

"Standard": Computers; office equipment; communications equipment; test and measurement equipment; audio and visual equipment; home electronic appliances; machine tools; personal electronic equipment; and industrial robots.

"High Quality": Transportation equipment (automobiles, trains, ships, etc.); traffic control systems; anti-disaster systems; anti-crime systems; safety equipment; and medical equipment not specifically designed for life support.

"Specific": Aircraft; aerospace equipment; submersible repeaters; nuclear reactor control systems; medical equipment or systems for life support (e.g. artificial life support devices or systems), surgical implantations, or healthcare intervention (e.g. excision, etc.), and any other applications or purposes that pose a direct threat to human life.

8. You should use the Renesas Electronics products described in this document within the range specified by Renesas Electronics, especially with respect to the maximum rating, operating supply voltage range, movement power voltage range, heat radiation characteristics, installation and other product characteristics. Renesas Electronics shall have no liability for malfunctions or damages arising out of the use of Renesas Electronics products beyond such specified ranges.
9. Although Renesas Electronics endeavors to improve the quality and reliability of its products, semiconductor products have specific characteristics such as the occurrence of failure at a certain rate and malfunctions under certain use conditions. Further, Renesas Electronics products are not subject to radiation resistance design. Please be sure to implement safety measures to guard them against the possibility of physical injury, and injury or damage caused by fire in the event of the failure of a Renesas Electronics product, such as safety design for hardware and software including but not limited to redundancy, fire control and malfunction prevention, appropriate treatment for aging degradation or any other appropriate measures. Because the evaluation of microcomputer software alone is very difficult, please evaluate the safety of the final products or system manufactured by you.
10. Please contact a Renesas Electronics sales office for details as to environmental matters such as the environmental compatibility of each Renesas Electronics product. Please use Renesas Electronics products in compliance with all applicable laws and regulations that regulate the inclusion or use of controlled substances, including without limitation, the EU RoHS Directive. Renesas Electronics assumes no liability for damages or losses occurring as a result of your noncompliance with applicable laws and regulations.
11. This document may not be reproduced or duplicated, in any form, in whole or in part, without prior written consent of Renesas Electronics.
12. Please contact a Renesas Electronics sales office if you have any questions regarding the information contained in this document or Renesas Electronics products, or if you have any other inquiries.

(Note 1) "Renesas Electronics" as used in this document means Renesas Electronics Corporation and also includes its majority-owned subsidiaries.

(Note 2) "Renesas Electronics product(s)" means any product developed or manufactured by or for Renesas Electronics.

To all our customers

Regarding the change of names mentioned in the document, such as Hitachi Electric and Hitachi XX, to Renesas Technology Corp.

The semiconductor operations of Mitsubishi Electric and Hitachi were transferred to Renesas Technology Corporation on April 1st 2003. These operations include microcomputer, logic, analog and discrete devices, and memory chips other than DRAMs (flash memory, SRAMs etc.) Accordingly, although Hitachi, Hitachi, Ltd., Hitachi Semiconductors, and other Hitachi brand names are mentioned in the document, these names have in fact all been changed to Renesas Technology Corp. Thank you for your understanding. Except for our corporate trademark, logo and corporate statement, no changes whatsoever have been made to the contents of the document, and these changes do not constitute any alteration to the contents of the document itself.

Renesas Technology Home Page: <http://www.renesas.com>

Renesas Technology Corp.
Customer Support Dept.
April 1, 2003

Cautions

Keep safety first in your circuit designs!

1. Renesas Technology Corporation puts the maximum effort into making semiconductor products better and more reliable, but there is always the possibility that trouble may occur with them. Trouble with semiconductors may lead to personal injury, fire or property damage.
Remember to give due consideration to safety when making your circuit designs, with appropriate measures such as (i) placement of substitutive, auxiliary circuits, (ii) use of nonflammable material or (iii) prevention against any malfunction or mishap.

Notes regarding these materials

1. These materials are intended as a reference to assist our customers in the selection of the Renesas Technology Corporation product best suited to the customer's application; they do not convey any license under any intellectual property rights, or any other rights, belonging to Renesas Technology Corporation or a third party.
2. Renesas Technology Corporation assumes no responsibility for any damage, or infringement of any third-party's rights, originating in the use of any product data, diagrams, charts, programs, algorithms, or circuit application examples contained in these materials.
3. All information contained in these materials, including product data, diagrams, charts, programs and algorithms represents information on products at the time of publication of these materials, and are subject to change by Renesas Technology Corporation without notice due to product improvements or other reasons. It is therefore recommended that customers contact Renesas Technology Corporation or an authorized Renesas Technology Corporation product distributor for the latest product information before purchasing a product listed herein.
The information described here may contain technical inaccuracies or typographical errors.
Renesas Technology Corporation assumes no responsibility for any damage, liability, or other loss rising from these inaccuracies or errors.
Please also pay attention to information published by Renesas Technology Corporation by various means, including the Renesas Technology Corporation Semiconductor home page (<http://www.renesas.com>).
4. When using any or all of the information contained in these materials, including product data, diagrams, charts, programs, and algorithms, please be sure to evaluate all information as a total system before making a final decision on the applicability of the information and products. Renesas Technology Corporation assumes no responsibility for any damage, liability or other loss resulting from the information contained herein.
5. Renesas Technology Corporation semiconductors are not designed or manufactured for use in a device or system that is used under circumstances in which human life is potentially at stake. Please contact Renesas Technology Corporation or an authorized Renesas Technology Corporation product distributor when considering the use of a product contained herein for any specific purposes, such as apparatus or systems for transportation, vehicular, medical, aerospace, nuclear, or undersea repeater use.
6. The prior written approval of Renesas Technology Corporation is necessary to reprint or reproduce in whole or in part these materials.
7. If these products or technologies are subject to the Japanese export control restrictions, they must be exported under a license from the Japanese government and cannot be imported into a country other than the approved destination.
Any diversion or reexport contrary to the export control laws and regulations of Japan and/or the country of destination is prohibited.
8. Please contact Renesas Technology Corporation for further details on these materials or the products contained therein.

The revision list can be viewed directly by clicking the title page.

The revision list summarizes the locations of revisions and additions. Details should always be checked by referring to the relevant text.

H8/3867 Series

H8/3827 Series

Hardware Manual

H8/3867 HD6473867, HD6433867

H8/3866 HD6433866

H8/3865 HD6433865

H8/3864 HD6433864

H8/3863 HD6433863

H8/3862 HD6433862

H8/3827 HD6473827, HD6433827

H8/3826 HD6433826

H8/3825 HD6433825

H8/3824 HD6433824

H8/3823 HD6433823

H8/3822 HD6433822

Cautions

1. Hitachi neither warrants nor grants licenses of any rights of Hitachi's or any third party's patent, copyright, trademark, or other intellectual property rights for information contained in this document. Hitachi bears no responsibility for problems that may arise with third party's rights, including intellectual property rights, in connection with use of the information contained in this document.
2. Products and product specifications may be subject to change without notice. Confirm that you have received the latest product standards or specifications before final design, purchase or use.
3. Hitachi makes every attempt to ensure that its products are of high quality and reliability. However, contact Hitachi's sales office before using the product in an application that demands especially high quality and reliability or where its failure or malfunction may directly threaten human life or cause risk of bodily injury, such as aerospace, aeronautics, nuclear power, combustion control, transportation, traffic, safety equipment or medical equipment for life support.
4. Design your application so that the product is used within the ranges guaranteed by Hitachi particularly for maximum rating, operating supply voltage range, heat radiation characteristics, installation conditions and other characteristics. Hitachi bears no responsibility for failure or damage when used beyond the guaranteed ranges. Even within the guaranteed ranges, consider normally foreseeable failure rates or failure modes in semiconductor devices and employ systemic measures such as fail-safes, so that the equipment incorporating Hitachi product does not cause bodily injury, fire or other consequential damage due to operation of the Hitachi product.
5. This product is not designed to be radiation resistant.
6. No one is permitted to reproduce or duplicate, in any form, the whole or part of this document without written approval from Hitachi.
7. Contact Hitachi's sales office for any questions regarding this document or Hitachi semiconductor products.

List of Items Revised or Added for This Version

| Page | Item | Description |
|------|--|---|
| 1 | Table 1.1 Features / CPU | Change in (2) High-speed calculation specification |
| 2 | Table 1.1 Features / Clock pulse generators | Change in specification |
| 3 | Table 1.1 Features / LCD drive power supply | Addition |
| 5 | Figure 1.1 Block Diagram | Modification |
| 8 | Table 1.2 Pin Functions / Power source pin | Modification of stabilization capacitance |
| 13 | 2.1.1 Features | Change in High-speed operation |
| 88 | Figure 4.2 Typical Connection to Crystal Oscillator | Addition of recommended value |
| 89 | Figure 4.4 Typical Connection to Ceramic Oscillator | Addition of recommended value |
| 91 | Figure 4.7 Typical Connection to 32.768-kHz/38.4 kHz Crystal Oscillator (Subclock) | Addition of description |
| 92 | Figure 4.9 Pin Connection when not Using Subclock | Modification |
| 95 | Table 5.1 Operating Modes | Modification of subsleep mode/watch mode descriptions |
| 97 | Table 5.2 Internal State in Each Operating Mode | Modification of Note 4 |
| 99 | 5.1.1 System Control Registers 1. System control register 1 (SYSCR1) | Addition of Notes to Bits 6 to 4 |
| 100 | 2. System control register 2 (SYSCR2) | Modification of Bit 4 contents |
| 102 | 5.2 Sleep Mode | Addition of description |
| 104 | 5.3.3 Oscillator Settling Timer after Standby Mode is Cleared | Addition of description |
| 107 | 5.5.2 Clearing Subsleep Mode • Clearing by interrupt | Addition of description |
| 109 | 5.7.1 Transition to Active (Medium-Speed) Mode | Addition of description |
| 147 | Table 8.10 Port 3 Pin States | Modification |
| 226 | Table 9.13 Timer G Operation Modes | Addition of description in Notes |
| 248 | 9.7.5 Application Notes | Addition and modification of descriptions |
| 251 | Figure 10.1 SCI3 Block Diagram | Modification |

| Page | Item | Description |
|-------------|--|---|
| 256 | 10.2.5 Serial Mode Register (SMR) / Bits 1 and 0 | Addition of description in Notes |
| 265 | Table 10.4 Relation between n and Clock | Addition of description in Notes |
| 266 | Table 10.5 Maximum Bit Rate for Each Frequency (Asynchronous Mode) | Modification of Notes |
| 267 | Table 10.7 Relation between n and Clock | Addition of description in Notes |
| 268 | 10.2.9 Clock Stop Register 1 (CKSTPR1) | Addition of description in Notes for Bits 6 and 5 |
| 303 | 10.5 Application Notes | Addition of 9 and 10. |
| 357 | 14.2 When Using the Internal Power Supply Step-Down Circuit | Modification of description |
| 360 to 362 | 15.2.1 Power Supply Voltage and Operating Range | Modification of 1 to 3 |
| 363 to 368 | Table 15.2 DC Characteristics | Addition and modification |
| 369 to 370 | Table 15.3 Control Signal Timing | Addition and modification |
| 371 | Table 15.4 Serial Interface (SCI3-1, SCI3-2) Timing | Addition of Notes |
| 372 | Table 15.5 A/D Converter Characteristics | Modification |
| 373 | Table 15.7 AC Characteristics for External Segment Expansion | Addition |
| 376 | Figure 15.6 SCI-3 Synchronous Mode Input/Output Timing | Modification of Notes |
| 377 | Figure 15.7 Segment Expansion Signal Timing | Addition |

Preface

The H8/300L Series of single-chip microcomputers has the high-speed H8/300L CPU at its core, with many necessary peripheral functions on-chip. The H8/300L CPU instruction set is compatible with the H8/300 CPU.

The H8/3867 Series and H8/3827 Series have a system-on-a-chip architecture that includes such peripheral functions as a as an LCD controller/driver, six timers, a 14-bit PWM, a two-channel serial communication interface, and an A/D converter. This allows H8/3867 Series devices to be used as embedded microcomputers in systems requiring LCD display.

The H8/3867 Series incorporates an LCD drive power supply and step-up constant power supply (5 V), enabling a fixed 5 V voltage to be obtained independently of V_{CC} .

This manual describes the hardware of the H8/3867 Series and H8/3827 Series. For details on the H8/3864 Series instruction set, refer to the H8/300L Series Programming Manual.

Contents

| | | |
|-----------|--|----|
| Section 1 | Overview..... | 1 |
| 1.1 | Overview..... | 1 |
| 1.2 | Internal Block Diagram | 6 |
| 1.3 | Pin Arrangement and Functions | 7 |
| 1.3.1 | Pin Arrangement | 7 |
| 1.3.2 | Pin Functions..... | 9 |
| Section 2 | CPU..... | 13 |
| 2.1 | Overview..... | 13 |
| 2.1.1 | Features | 13 |
| 2.1.2 | Address Space | 14 |
| 2.1.3 | Register Configuration | 14 |
| 2.2 | Register Descriptions..... | 15 |
| 2.2.1 | General Registers..... | 15 |
| 2.2.2 | Control Registers..... | 15 |
| 2.2.3 | Initial Register Values..... | 16 |
| 2.3 | Data Formats..... | 17 |
| 2.3.1 | Data Formats in General Registers..... | 18 |
| 2.3.2 | Memory Data Formats..... | 19 |
| 2.4 | Addressing Modes | 20 |
| 2.4.1 | Addressing Modes..... | 20 |
| 2.4.2 | Effective Address Calculation..... | 22 |
| 2.5 | Instruction Set..... | 26 |
| 2.5.1 | Data Transfer Instructions..... | 28 |
| 2.5.2 | Arithmetic Operations | 30 |
| 2.5.3 | Logic Operations | 31 |
| 2.5.4 | Shift Operations..... | 31 |
| 2.5.5 | Bit Manipulations | 33 |
| 2.5.6 | Branching Instructions..... | 37 |
| 2.5.7 | System Control Instructions | 39 |
| 2.5.8 | Block Data Transfer Instruction | 40 |
| 2.6 | Basic Operational Timing..... | 42 |
| 2.6.1 | Access to On-Chip Memory (RAM, ROM) | 42 |
| 2.6.2 | Access to On-Chip Peripheral Modules | 43 |
| 2.7 | CPU States..... | 45 |
| 2.7.1 | Overview | 45 |
| 2.7.2 | Program Execution State | 46 |
| 2.7.3 | Program Halt State..... | 46 |
| 2.7.4 | Exception-Handling State | 46 |

| | | |
|------------------|---|-----------|
| 2.8 | Memory Map | 47 |
| 2.8.1 | Memory Map..... | 47 |
| 2.9 | Application Notes..... | 53 |
| 2.9.1 | Notes on Data Access..... | 53 |
| 2.9.2 | Notes on Bit Manipulation | 55 |
| 2.9.3 | Notes on Use of the EEPMOV Instruction | 61 |
| Section 3 | Exception Handling..... | 63 |
| 3.1 | Overview..... | 63 |
| 3.2 | Reset | 63 |
| 3.2.1 | Overview | 63 |
| 3.2.2 | Reset Sequence..... | 63 |
| 3.2.3 | Interrupt Immediately after Reset | 65 |
| 3.3 | Interrupts..... | 65 |
| 3.3.1 | Overview | 65 |
| 3.3.2 | Interrupt Control Registers | 67 |
| 3.3.3 | External Interrupts..... | 76 |
| 3.3.4 | Internal Interrupts | 77 |
| 3.3.5 | Interrupt Operations..... | 78 |
| 3.3.6 | Interrupt Response Time | 83 |
| 3.4 | Application Notes..... | 84 |
| 3.4.1 | Notes on Stack Area Use..... | 84 |
| 3.4.2 | Notes on Rewriting Port Mode Registers..... | 85 |
| Section 4 | Clock Pulse Generators..... | 87 |
| 4.1 | Overview..... | 87 |
| 4.1.1 | Block Diagram..... | 87 |
| 4.1.2 | System Clock and Subclock | 87 |
| 4.2 | System Clock Generator..... | 88 |
| 4.3 | Subclock Generator | 91 |
| 4.4 | Prescalers | 93 |
| 4.5 | Note on Oscillators | 94 |
| Section 5 | Power-Down Modes | 95 |
| 5.1 | Overview..... | 95 |
| 5.1.1 | System Control Registers | 98 |
| 5.2 | Sleep Mode..... | 103 |
| 5.2.1 | Transition to Sleep Mode | 103 |
| 5.2.2 | Clearing Sleep Mode..... | 103 |
| 5.2.3 | Clock Frequency in Sleep (Medium-Speed) Mode..... | 104 |
| 5.3 | Standby Mode..... | 104 |
| 5.3.1 | Transition to Standby Mode | 104 |
| 5.3.2 | Clearing Standby Mode..... | 104 |

| | | |
|---------------------------------|---|------------|
| 5.3.3 | Oscillator Settling Time after Standby Mode is Cleared..... | 105 |
| 5.3.4 | Standby Mode Transition and Pin States..... | 106 |
| 5.4 | Watch Mode | 107 |
| 5.4.1 | Transition to Watch Mode..... | 107 |
| 5.4.2 | Clearing Watch Mode | 107 |
| 5.4.3 | Oscillator Settling Time after Watch Mode is Cleared | 107 |
| 5.5 | Subsleep Mode | 108 |
| 5.5.1 | Transition to Subsleep Mode..... | 108 |
| 5.5.2 | Clearing Subsleep Mode | 108 |
| 5.6 | Subactive Mode | 109 |
| 5.6.1 | Transition to Subactive Mode | 109 |
| 5.6.2 | Clearing Subactive Mode | 109 |
| 5.6.3 | Operating Frequency in Subactive Mode | 109 |
| 5.7 | Active (Medium-Speed) Mode..... | 110 |
| 5.7.1 | Transition to Active (Medium-Speed) Mode | 110 |
| 5.7.2 | Clearing Active (Medium-Speed) Mode..... | 110 |
| 5.7.3 | Operating Frequency in Active (Medium-Speed) Mode..... | 110 |
| 5.8 | Direct Transfer..... | 111 |
| 5.8.1 | Overview of Direct Transfer | 111 |
| 5.8.2 | Direct Transition Times..... | 112 |
| 5.9 | Module Standby Mode | 115 |
| 5.9.1 | Setting Module Standby Mode..... | 115 |
| 5.9.2 | Clearing Module Standby Mode | 115 |
| Section 6 ROM..... | | 117 |
| 6.1 | Overview..... | 117 |
| 6.1.1 | Block Diagram..... | 117 |
| 6.2 | H8/3867 and H8/3827 PROM Mode..... | 118 |
| 6.2.1 | Setting to PROM Mode..... | 118 |
| 6.2.2 | Socket Adapter Pin Arrangement and Memory Map | 118 |
| 6.3 | H8/3867 and H8/3827 Programming | 121 |
| 6.3.1 | Writing and Verifying | 121 |
| 6.3.2 | Programming Precautions | 126 |
| 6.4 | Reliability of Programmed Data..... | 127 |
| Section 7 RAM..... | | 129 |
| 7.1 | Overview..... | 129 |
| 7.1.1 | Block Diagram..... | 129 |
| Section 8 I/O Ports..... | | 131 |
| 8.1 | Overview..... | 131 |
| 8.2 | Port 1..... | 133 |
| 8.2.1 | Overview | 133 |

| | | |
|-------|--|-----|
| 8.2.2 | Register Configuration and Description | 133 |
| 8.2.3 | Pin Functions | 138 |
| 8.2.4 | Pin States | 140 |
| 8.2.5 | MOS Input Pull-Up | 140 |
| 8.3 | Port 3 | 141 |
| 8.3.1 | Overview | 141 |
| 8.3.2 | Register Configuration and Description | 141 |
| 8.3.3 | Pin Functions | 145 |
| 8.3.4 | Pin States | 147 |
| 8.3.5 | MOS Input Pull-Up | 147 |
| 8.4 | Port 4 | 148 |
| 8.4.1 | Overview | 148 |
| 8.4.2 | Register Configuration and Description | 148 |
| 8.4.3 | Pin Functions | 149 |
| 8.4.4 | Pin States | 150 |
| 8.5 | Port 5 | 151 |
| 8.5.1 | Overview | 151 |
| 8.5.2 | Register Configuration and Description | 151 |
| 8.5.3 | Pin Functions | 154 |
| 8.5.4 | Pin States | 154 |
| 8.5.5 | MOS Input Pull-Up | 155 |
| 8.6 | Port 6 | 156 |
| 8.6.1 | Overview | 156 |
| 8.6.2 | Register Configuration and Description | 156 |
| 8.6.3 | Pin Functions | 158 |
| 8.6.4 | Pin States | 158 |
| 8.6.5 | MOS Input Pull-Up | 159 |
| 8.7 | Port 7 | 160 |
| 8.7.1 | Overview | 160 |
| 8.7.2 | Register Configuration and Description | 160 |
| 8.7.3 | Pin Functions | 162 |
| 8.7.4 | Pin States | 162 |
| 8.8 | Port 8 | 163 |
| 8.8.1 | Overview | 163 |
| 8.8.2 | Register Configuration and Description | 163 |
| 8.8.3 | Pin Functions | 165 |
| 8.8.4 | Pin States | 166 |
| 8.9 | Port A | 167 |
| 8.9.1 | Overview | 167 |
| 8.9.2 | Register Configuration and Description | 167 |
| 8.9.3 | Pin Functions | 169 |
| 8.9.4 | Pin States | 170 |
| 8.10 | Port B | 171 |

| | | |
|-------------------------------|---|------------|
| 8.10.1 | Overview | 171 |
| 8.10.2 | Register Configuration and Description | 171 |
| 8.11 | Input/Output Data Inversion Function | 172 |
| 8.11.1 | Overview | 172 |
| 8.11.2 | Register Configuration and Descriptions | 172 |
| 8.11.3 | Note on Modification of Serial Port Control Register..... | 174 |
| Section 9 Timers | | 175 |
| 9.1 | Overview..... | 175 |
| 9.2 | Timer A..... | 177 |
| 9.2.1 | Overview | 177 |
| 9.2.2 | Register Descriptions..... | 179 |
| 9.2.3 | Timer Operation | 183 |
| 9.2.4 | Timer A Operation States | 184 |
| 9.3 | Timer C..... | 185 |
| 9.3.1 | Overview | 185 |
| 9.3.2 | Register Descriptions..... | 187 |
| 9.3.3 | Timer Operation | 191 |
| 9.3.4 | Timer C Operation States | 193 |
| 9.4 | Timer F..... | 194 |
| 9.4.1 | Overview | 194 |
| 9.4.2 | Register Descriptions..... | 197 |
| 9.4.3 | CPU Interface | 205 |
| 9.4.4 | Operation | 208 |
| 9.4.5 | Application Notes | 211 |
| 9.5 | Timer G..... | 213 |
| 9.5.1 | Overview | 213 |
| 9.5.2 | Register Descriptions..... | 216 |
| 9.5.3 | Noise Canceler..... | 221 |
| 9.5.4 | Operation | 223 |
| 9.5.5 | Application Notes | 227 |
| 9.5.6 | Timer G Application Example | 232 |
| 9.6 | Watchdog Timer | 233 |
| 9.6.1 | Overview | 233 |
| 9.6.2 | Register Descriptions..... | 234 |
| 9.6.3 | Timer Operation | 238 |
| 9.6.4 | Watchdog Timer Operation States | 239 |
| 9.7 | Asynchronous Event Counter (AEC) | 240 |
| 9.7.1 | Overview | 240 |
| 9.7.2 | Register Descriptions..... | 242 |
| 9.7.3 | Operation | 247 |
| 9.7.4 | Asynchronous Event Counter Operation Modes..... | 248 |
| 9.7.5 | Application Notes | 249 |

| | | |
|------------|--|-----|
| Section 10 | Serial Communication Interface | 251 |
| 10.1 | Overview..... | 251 |
| 10.1.1 | Features | 251 |
| 10.1.2 | Block diagram | 253 |
| 10.1.3 | Pin configuration..... | 254 |
| 10.1.4 | Register configuration | 254 |
| 10.2 | Register Descriptions..... | 255 |
| 10.2.1 | Receive shift register (RSR)..... | 255 |
| 10.2.2 | Receive data register (RDR) | 255 |
| 10.2.3 | Transmit shift register (TSR)..... | 256 |
| 10.2.4 | Transmit data register (TDR) | 256 |
| 10.2.5 | Serial mode register (SMR)..... | 257 |
| 10.2.6 | Serial control register 3 (SCR3) | 260 |
| 10.2.7 | Serial status register (SSR)..... | 264 |
| 10.2.8 | Bit rate register (BRR)..... | 268 |
| 10.2.9 | Clock stop register 1 (CKSTPR1)..... | 272 |
| 10.2.10 | Serial Port Control Register (SPCR)..... | 273 |
| 10.3 | Operation | 275 |
| 10.3.1 | Overview | 275 |
| 10.3.2 | Operation in Asynchronous Mode..... | 279 |
| 10.3.3 | Operation in Synchronous Mode..... | 289 |
| 10.3.4 | Multiprocessor Communication Function..... | 296 |
| 10.4 | Interrupts..... | 303 |
| 10.5 | Application Notes..... | 304 |
| Section 11 | 14-Bit PWM..... | 309 |
| 11.1 | Overview..... | 309 |
| 11.1.1 | Features | 309 |
| 11.1.2 | Block Diagram..... | 309 |
| 11.1.3 | Pin Configuration | 310 |
| 11.1.4 | Register Configuration | 310 |
| 11.2 | Register Descriptions..... | 311 |
| 11.2.1 | PWM Control Register (PWCR)..... | 311 |
| 11.2.2 | PWM Data Registers U and L (PWDRU, PWDRL)..... | 312 |
| 11.2.3 | Clock Stop Register 2 (CKSTPR2)..... | 312 |
| 11.3 | Operation | 314 |
| 11.3.1 | Operation..... | 314 |
| 11.3.2 | PWM Operation Modes..... | 315 |
| Section 12 | A/D Converter..... | 317 |
| 12.1 | Overview..... | 317 |
| 12.1.1 | Features | 317 |
| 12.1.2 | Block Diagram..... | 318 |

| | | |
|--|--|------------|
| 12.1.3 | Pin Configuration | 319 |
| 12.1.4 | Register Configuration | 319 |
| 12.2 | Register Descriptions | 320 |
| 12.2.1 | A/D Result Registers (ADRRH, ADRL) | 320 |
| 12.2.2 | A/D Mode Register (AMR) | 320 |
| 12.2.3 | A/D Start Register (ADSR) | 322 |
| 12.2.4 | Clock Stop Register 1 (CKSTPR1) | 323 |
| 12.3 | Operation | 324 |
| 12.3.1 | A/D Conversion Operation | 324 |
| 12.3.2 | Start of A/D Conversion by External Trigger Input | 324 |
| 12.3.3 | A/D Converter Operation Modes | 325 |
| 12.4 | Interrupts | 325 |
| 12.5 | Typical Use | 325 |
| 12.6 | Application Notes | 328 |
| Section 13 LCD Controller/Driver | | 329 |
| 13.1 | Overview | 329 |
| 13.1.1 | Features | 329 |
| 13.1.2 | Block Diagram | 330 |
| 13.1.3 | Pin Configuration | 331 |
| 13.1.4 | Register Configuration | 331 |
| 13.2 | Register Descriptions | 332 |
| 13.2.1 | LCD Port Control Register (LPCR) | 332 |
| 13.2.2 | LCD Control Register (LCR) | 334 |
| 13.2.3 | LCD Control Register 2 (LCR2) | 336 |
| 13.2.4 | Clock Stop Register 2 (CKSTPR2) | 338 |
| 13.3 | Operation | 339 |
| 13.3.1 | Settings up to LCD Display | 339 |
| 13.3.2 | Relationship between LCD RAM and Display | 342 |
| 13.3.3 | Luminance Adjustment Function (V0 Pin) | 349 |
| 13.3.4 | Step-Up Constant-Voltage (5 V) Power Supply | 350 |
| 13.3.5 | Low-Power-Consumption LCD Drive System | 350 |
| 13.3.6 | Operation in Power-Down Modes | 354 |
| 13.3.7 | Boosting the LCD Drive Power Supply | 355 |
| 13.3.8 | Connection to HD66100 | 356 |
| Section 14 Power Supply Circuit | | 359 |
| 14.1 | Overview | 359 |
| 14.2 | When Using the Internal Power Supply Step-Down Circuit | 359 |
| 14.3 | When Not Using the Internal Power Supply Step-Down Circuit | 360 |
| Section 15 Electrical Characteristics | | 361 |
| 15.1 | H8/3867 Series and H8/3827 Series Absolute Maximum Ratings | 361 |

| | | |
|--|--|------------|
| 15.2 | H8/3867 Series and H8/3827 Series Electrical Characteristics | 362 |
| 15.2.1 | Power Supply Voltage and Operating Range | 362 |
| 15.2.2 | DC Characteristics..... | 365 |
| 15.2.3 | AC Characteristics..... | 371 |
| 15.2.4 | A/D Converter Characteristics | 374 |
| 15.2.5 | LCD Characteristics | 376 |
| 15.3 | Operation Timing | 378 |
| 15.4 | Output Load Circuit..... | 382 |
| 15.5 | Resonator Equivalent Circuit | 382 |
| Appendix A CPU Instruction Set..... | | 383 |
| A.1 | Instructions | 383 |
| A.2 | Operation Code Map..... | 391 |
| A.3 | Number of Execution States..... | 393 |
| Appendix B Internal I/O Registers..... | | 399 |
| B.1 | Addresses..... | 399 |
| B.2 | Functions..... | 403 |
| Appendix C I/O Port Block Diagrams | | 454 |
| C.1 | Block Diagrams of Port 1 | 454 |
| C.2 | Block Diagrams of Port 3 | 457 |
| C.3 | Block Diagrams of Port 4..... | 464 |
| C.4 | Block Diagram of Port 5..... | 468 |
| C.5 | Block Diagram of Port 6..... | 469 |
| C.6 | Block Diagram of Port 7..... | 470 |
| C.7 | Block Diagrams of Port 8..... | 471 |
| C.8 | Block Diagram of Port A..... | 472 |
| C.9 | Block Diagram of Port B | 473 |
| Appendix D Port States in the Different Processing States | | 474 |
| Appendix E List of Product Codes | | 475 |
| Appendix F Package Dimensions | | 477 |

Section 1 Overview

1.1 Overview

The H8/300L Series is a series of single-chip microcomputers (MCU: microcomputer unit), built around the high-speed H8/300L CPU and equipped with peripheral system functions on-chip.

Within the H8/300L Series, the H8/3867 Series and H8/3827 Series comprise single-chip microcomputers equipped with a controller/driver. Other on-chip peripheral functions include six timers, a 14-bit pulse width modulator (PWM), two serial communication interface channels, and an A/D converter. Together, these functions make the H8/3864 Series ideally suited for embedded applications in systems requiring low power consumption and LCD display. Models in the H8/3867 and H8/3827 Series are the H8/3862 and H8/3822, with on-chip 16-kbyte ROM and 1-kbyte RAM, the H8/3863 and H8/3823, with 24-kbyte ROM and 1-kbyte RAM, the H8/3864 and H8/3824, with 32-kbyte ROM and 2-kbyte RAM, the H8/3865 and H8/3825, with 40-kbyte ROM and 2-kbyte RAM, the H8/3866 and H8/3826, with 48-kbyte ROM and 2-kbyte RAM, and the H8/3867 and H8/3827, with 60-kbyte ROM and 2-kbyte RAM.

The H8/3867 and H8/3827 are also available in a ZTAT™* version with on-chip PROM which can be programmed as required by the user.

Table 1.1 summarizes the features of the H8/3867 Series and H8/3827 Series.

Note: * ZTAT (Zero Turn Around Time) is a trademark of Hitachi, Ltd.

Table 1.1 Features

| Item | Description |
|------------------------|--|
| CPU | <p>High-speed H8/300L CPU</p> <ul style="list-style-type: none">• General-register architecture General registers: Sixteen 8-bit registers (can be used as eight 16-bit registers)• Operating speed<ul style="list-style-type: none">— Max. operating speed: 3 MHz— Add/subtract: 0.67 μs (operating at 3 MHz)— Multiply/divide: 4.67 μs (operating at 3 MHz)— Can run on 32.768 kHz or 38.4 kHz subclock• Instruction set compatible with H8/300 CPU<ul style="list-style-type: none">— Instruction length of 2 bytes or 4 bytes— Basic arithmetic operations between registers— MOV instruction for data transfer between memory and registers• Typical instructions<ul style="list-style-type: none">— Multiply (8 bits \times 8 bits)— Divide (16 bits \div 8 bits)— Bit accumulator— Register-indirect designation of bit position |
| Interrupts | <p>36 interrupt sources</p> <ul style="list-style-type: none">• 13 external interrupt sources (IRQ₄ to IRQ₀, WKP₇ to WKP₀)• 23 internal interrupt sources |
| Clock pulse generators | <p>Two on-chip clock pulse generators</p> <ul style="list-style-type: none">• System clock pulse generator: 0.4 to 6 MHz• Subclock pulse generator: 32.768 kHz, 38.4 kHz |
| Power-down modes | <p>Seven power-down modes</p> <ul style="list-style-type: none">• Sleep (high-speed) mode• Sleep (medium-speed) mode• Standby mode• Watch mode• Subsleap mode• Subactive mode• Active (medium-speed) mode |

Table 1.1 Features (cont)

| Item | Description |
|-------------|---|
| Memory | <p data-bbox="346 124 587 153">Large on-chip memory</p> <ul style="list-style-type: none"> <li data-bbox="346 169 900 197">• H8/3862, H8/3822: 16-kbyte ROM, 1-kbyte RAM <li data-bbox="346 209 900 237">• H8/3863, H8/3823: 24-kbyte ROM, 1-kbyte RAM <li data-bbox="346 248 900 277">• H8/3864, H8/3824: 32-kbyte ROM, 2-kbyte RAM <li data-bbox="346 288 900 317">• H8/3865, H8/3825: 40-kbyte ROM, 2-kbyte RAM <li data-bbox="346 328 900 357">• H8/3866, H8/3826: 48-kbyte ROM, 2-kbyte RAM <li data-bbox="346 368 900 397">• H8/3867, H8/3827: 60-kbyte ROM, 2-kbyte RAM |
| I/O ports | <p data-bbox="346 416 422 445">64 pins</p> <ul style="list-style-type: none"> <li data-bbox="346 461 503 489">• 55 I/O pins <li data-bbox="346 501 506 528">• 9 input pins |
| Timers | <p data-bbox="346 549 539 577">Six on-chip timers</p> <ul style="list-style-type: none"> <li data-bbox="346 593 1093 719">• Timer A: 8-bit timer Count-up timer with selection of eight internal clock signals divided from the system clock (ϕ)* and four clock signals divided from the watch clock (ϕ_w)* <li data-bbox="346 730 1048 831">• Asynchronous event counter: 16-bit timer — Count-up timer able to count asynchronous external events independently of the MCU's internal clocks <li data-bbox="346 842 1120 984">• Timer C: 8-bit timer — Count-up/down timer with selection of seven internal clock signals or event input from external pin — Auto-reloading <li data-bbox="346 995 1129 1182">• Timer F: 16-bit timer — Can be used as two independent 8-bit timers — Count-up timer with selection of four internal clock signals or event input from external pin — Provision for toggle output by means of compare-match function <li data-bbox="346 1193 1045 1303">• Timer G: 8-bit timer — Count-up timer with selection of four internal clock signals — Incorporates input capture function (built-in noise canceler) <li data-bbox="346 1315 964 1377">• Watchdog timer — Reset signal generated by overflow of 8-bit counter |

Note: * See section 4, Clock Pulse Generator, for the definition of ϕ and ϕ_w .

Table 1.1 Features (cont)

| Item | Description |
|--------------------------------|---|
| Serial communication interface | Two serial communication interface channels on chip <ul style="list-style-type: none">• SCI3-1: 8-bit synchronous/asynchronous serial interface Incorporates multiprocessor communication function• SCI3-2: 8-bit synchronous/asynchronous serial interface Incorporates multiprocessor communication function |
| 14-bit PWM | Pulse-division PWM output for reduced ripple <ul style="list-style-type: none">• Can be used as a 14-bit D/A converter by connecting to an external low-pass filter. |
| A/D converter | Successive approximations using a resistance ladder <ul style="list-style-type: none">• 8-channel analog input pins• Conversion time: 31/∅ or 62/∅ per channel |
| LCD controller/driver | LCD controller/driver equipped with a maximum of 32 segment pins and four common pins <ul style="list-style-type: none">• Choice of four duty cycles (static, 1/2, 1/3, or 1/4)• Segment pins can be switched to general-purpose port function in 8-bit units |
| LCD drive power supply | Step-up constant-voltage power supply allows LCD display (H8/3867 Series only) |

Table 1.1 Features (cont)

| Item | Specification | | | |
|----------------|---------------------------|---------------------------|-----------------------|-------------------------------|
| | Product Code | | | |
| Product lineup | Mask ROM Version | ZTAT Version | Package | ROM/RAM Size |
| | HD6433862H, HD6433822H | — | 80-pin QFP (FP-80A) | ROM 16 kbytes RAM 1 kbyte |
| | HD6433862F, HD6433822F | — | 80-pin QFP (FP-80B) | |
| | HD6433862W, HD6433822W | — | 80-pin TQFP (TFP-80C) | |
| | HD6433863H, HD6433823H | — | 80-pin QFP (FP-80A) | ROM 24 kbytes RAM 1 kbyte |
| | HD6433863F, HD6433823F | — | 80-pin QFP (FP-80B) | |
| | HD6433863W, HD6433823W | — | 80-pin TQFP (TFP-80C) | |
| | HD6433864H, HD6433824H | — | 80-pin QFP (FP-80A) | ROM 32 kbytes RAM 2 kbytes |
| | HD6433864F, HD6433824F | — | 80-pin QFP (FP-80B) | |
| | HD6433864W, HD6433824W | — | 80-pin TQFP (TFP-80C) | |
| | HD6433865H, HD6433825H | — | 80-pin QFP (FP-80A) | ROM 40 kbytes RAM 2 kbytes |
| | HD6433865F, HD6433825F | — | 80-pin QFP (FP-80B) | |
| | HD6433865W, HD6433825W | — | 80-pin TQFP (TFP-80C) | |
| | HD6433866H, HD6433826H | — | 80-pin QFP (FP-80A) | ROM 48 kbytes RAM 2 kbytes |
| | HD6433866F, HD6433826F | — | 80-pin QFP (FP-80B) | |
| | HD6433866W, HD6433826W | — | 80-pin TQFP (TFP-80C) | |
| | HD6433867H, HD6433827H | HD6473867H, HD6473827H | 80-pin QFP (FP-80A) | ROM 60 kbytes RAM 2 kbytes |
| | HD6433867F, HD6433827F | HD6473867F, HD6473827F | 80-pin QFP (FP-80B) | |
| | HD6433867W, HD6433827W | HD6473867W, HD6473827W | 80-pin TQFP (TFP-80C) | |

1.2 Internal Block Diagram

Figure 1.1 shows a block diagram of the H8/3867 Series and H8/3827 Series.

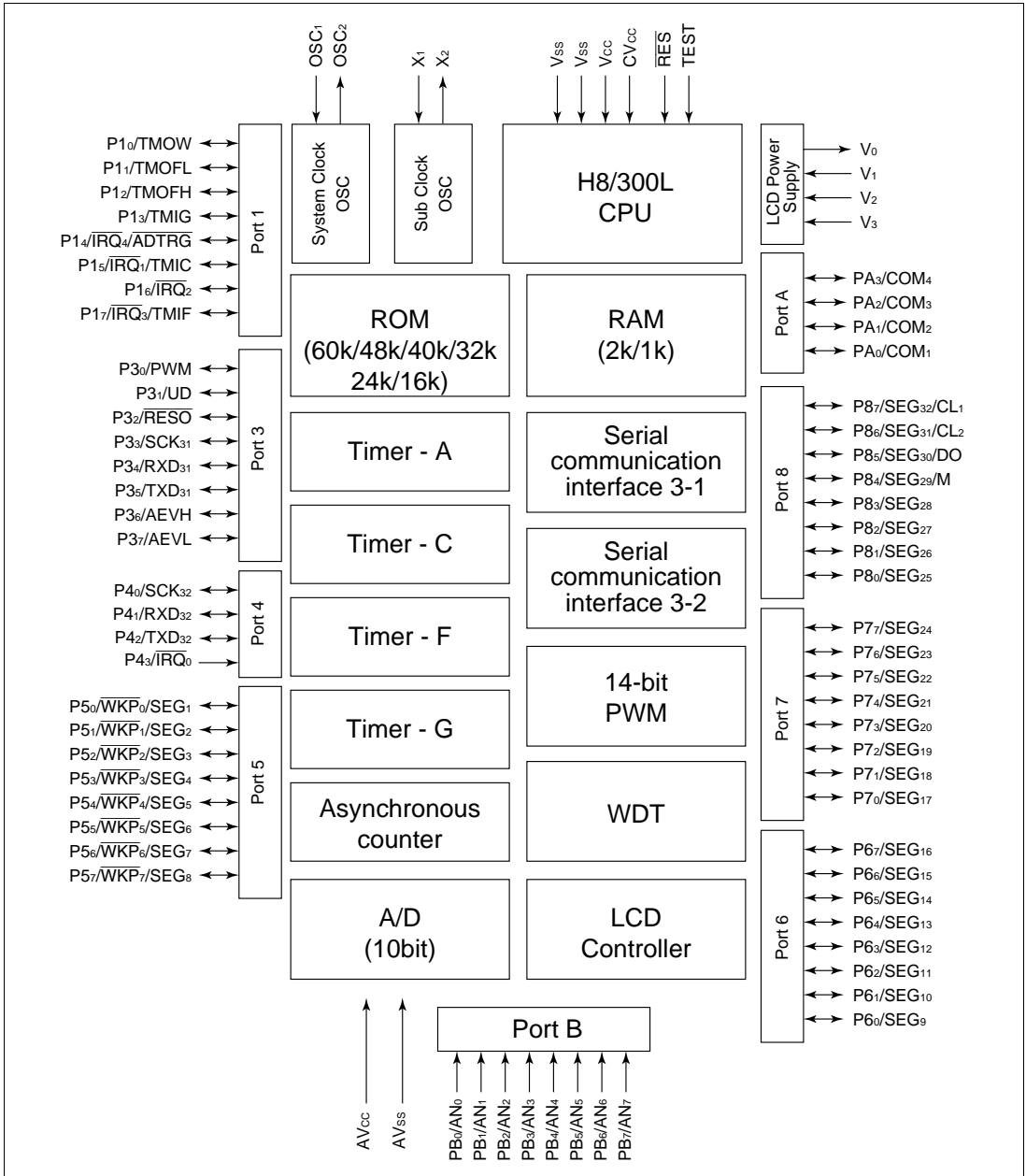

Figure 1.1 Block Diagram

1.3.2 Pin Functions

Table 1.2 outlines the pin functions of the H8/3864 Series.

Table 1.2 Pin Functions

| Type | Symbol | Pin No. | | I/O | Name and Functions |
|-------------------|------------------|-------------------|---------|--------|---|
| | | FP-80A TFP-80C | FP-80B | | |
| Power source pins | V_{CC} | 32 | 34 | Input | Power supply: All V_{CC} pins should be connected to the system power supply. See section 14, Power Supply Circuit. |
| | CV_{CC} | 26 | 28 | | |
| | V_{SS} | 5 27 | 7 29 | Input | Ground: All V_{SS} pins should be connected to the system power supply (0 V). |
| | AV_{CC} | 73 | 75 | Input | Analog power supply: This is the power supply pin for the A/D converter. When the A/D converter is not used, connect this pin to the system power supply. |
| | AV_{SS} | 2 | 4 | Input | Analog ground: This is the A/D converter ground pin. It should be connected to the system power supply (0V). |
| | V_0 | 31 | 33 | Output | LCD power supply: These are the power supply pins for the LCD controller/driver. They incorporate a power supply split-resistance, and are normally used with V_0 and V_1 shorted. |
| | V_1 | 30 | 32 | Input | |
| | V_2 | 29 | 31 | | |
| | V_3 | 28 | 30 | | |
| | | | | | |
| Clock pins | OSC_1 | 7 | 9 | Input | These pins connect to a crystal or ceramic oscillator, or can be used to input an external clock. See section 4, Clock Pulse Generators, for a typical connection diagram. |
| | OSC_2 | 6 | 8 | Output | |
| | X_1 | 3 | 5 | Input | These pins connect to a 32.768-kHz or 38.4-kHz crystal oscillator. See section 4, Clock Pulse Generators, for a typical connection diagram. |
| | X_2 | 4 | 6 | Output | |
| System control | \overline{RES} | 9 | 11 | Input | Reset: When this pin is driven low, the chip is reset |
| | $RESO$ | 20 | 22 | Output | Reset output: Outputs the CPU internal reset signal. |

Table 1.2 Pin Functions (cont)

| Type | Symbol | Pin No. | | I/O | Name and Functions |
|----------------|--|-------------------|----------|---|--|
| | | FP-80A TFP-80C | FP-80B | | |
| System control | TEST | 8 | 10 | Output | Test pin: This pin is reserved and cannot be used. It should be connected to V_{SS} . |
| Interrupt pins | \overline{IRQ}_0 | 72 | 74 | Input | IRQ interrupt request 0 to 4: These are input pins for edge-sensitive external interrupts, with a selection of rising or falling edge |
| | \overline{IRQ}_1 | 15 | 17 | | |
| | \overline{IRQ}_2 | 16 | 18 | | |
| | \overline{IRQ}_3 | 17 | 19 | | |
| | \overline{IRQ}_4 | 14 | 16 | | |
| | \overline{WKP}_7 to \overline{WKP}_0 | 44 to 37 | 46 to 39 | Input | Wakeup interrupt request 0 to 7: These are input pins for rising or falling-edge-sensitive external interrupts. |
| Timer pins | TMOW | 10 | 12 | Output | Clock output: This is an output pin for waveforms generated by the timer A output circuit. |
| | AEVL | 25 | 27 | Input | Asynchronous event counter event input: This is an event input pin for input to the asynchronous event counter. |
| | AEVH | 24 | 26 | | |
| | TMIC | 15 | 17 | Input | Timer C event input: This is an event input pin for input to the timer C counter. |
| | UD | 19 | 21 | Input | Timer C up/down select: This pin selects up- or down-counting for the timer C counter. The counter operates as an up-counter when this pin is high, and as a down-counter when low. |
| | TMIF | 17 | 19 | Input | Timer F event input: This is an event input pin for input to the timer F counter. |
| | TMOFL | 11 | 13 | Output | Timer FL output: This is an output pin for waveforms generated by the timer FL output compare function. |
| | TMOFH | 12 | 14 | Output | Timer FH output: This is an output pin for waveforms generated by the timer FH output compare function. |
| TMIG | 13 | 15 | Input | Timer G capture input: This is an input pin for timer G input capture. | |

Table 1.2 Pin Functions (cont)

| Type | Symbol | Pin No. | | I/O | Name and Functions |
|----------------|------------------------------------|-------------------|------------------|--------|---|
| | | FP-80A TFP-80C | FP-80B | | |
| 14-bit PWM pin | PWM | 18 | 20 | Output | 14-bit PWM output: This is an output pin for waveforms generated by the 14-bit PWM |
| I/O ports | PB ₇ to PB ₀ | 1, 80 to 74 | 3 to 1, 80 to 76 | Input | Port B: This is an 8-bit input port. |
| | P4 ₃ | 72 | 74 | Input | Port 4 (bit 3): This is a 1-bit input port. |
| | P4 ₂ to P4 ₀ | 71 to 69 | 73 to 71 | I/O | Port 4 (bits 2 to 0): This is a 3-bit I/O port. Input or output can be designated for each bit by means of port control register 4 (PCR4). |
| | PA ₃ to PA ₀ | 33 to 36 | 35 to 38 | I/O | Port A: This is a 4-bit I/O port. Input or output can be designated for each bit by means of port control register A (PCRA). |
| | P1 ₇ to P1 ₀ | 17 to 10 | 19 to 12 | I/O | Port 1: This is an 8-bit I/O port. Input or output can be designated for each bit by means of port control register 1 (PCR1). |
| | P3 ₇ to P3 ₀ | 25 to 18 | 27 to 20 | I/O | Port 3: This is an 8-bit I/O port. Input or output can be designated for each bit by means of port control register 3 (PCR3). |
| | P5 ₇ to P5 ₀ | 44 to 37 | 46 to 39 | I/O | Port 5: This is an 8-bit I/O port. Input or output can be designated for each bit by means of port control register 5 (PCR5). |
| | P6 ₇ to P6 ₀ | 52 to 45 | 54 to 47 | I/O | Port 6: This is an 8-bit I/O port. Input or output can be designated for each bit by means of port control register 6 (PCR6). |
| | P7 ₇ to P7 ₀ | 60 to 53 | 62 to 55 | I/O | Port 7: This is an 8-bit I/O port. Input or output can be designated for each bit by means of port control register 7 (PCR7). |
| | P8 ₇ to P8 ₀ | 68 to 61 | 70 to 63 | I/O | Port 8: This is an 8-bit I/O port. Input or output can be designated for each bit by means of port control register 8 (PCR8). |

Table 1.2 Pin Functions (cont)

| Type | Symbol | Pin No. | | I/O | Name and Functions |
|--------------------------------------|---------------------------------------|---------------|--------------------|--------|--|
| | | FP-80A | FP-80B | | |
| Serial communication interface (SCI) | RXD ₃₁ | 22 | 24 | Input | SCI3-1 receive data input: This is the SCI31 data input pin. |
| | TXD ₃₁ | 23 | 25 | Output | SCI3-1 transmit data output: This is the SCI31 data output pin. |
| | SCK ₃₁ | 21 | 23 | I/O | SCI3-1 clock I/O: This is the SCI31 clock I/O pin. |
| | RXD ₃₂ | 70 | 72 | Input | SCI3-2 receive data input: This is the SCI32 data input pin. |
| | TXD ₃₂ | 71 | 73 | Output | SCI3-2 transmit data output: This is the SCI32 data output pin. |
| | SCK ₃₂ | 69 | 71 | I/O | SCI3-2 clock I/O: This is the SCI32 clock I/O pin. |
| A/D converter | AN7 to An0 | 1 80 to 74 | 3 to 1 80 to 76 | Input | Analog input channels 7 to 0: These are analog data input channels to the A/D converter |
| | ADTRG | 14 | 16 | Input | A/D converter trigger input: This is the external trigger input pin to the A/D converter |
| LCD controller/driver | COM ₄ to COM ₁ | 33 to 36 | 35 to 38 | Output | LCD common output: These are the LCD common output pins. |
| | SEG ₃₂ to SEG ₁ | 68 to 37 | 70 to 39 | Output | LCD segment output: These are the LCD segment output pins. |
| | CL1 | 68 | 70 | Output | LCD latch clock: This is the output pin for the segment external expansion display data latch clock. |
| | CL2 | 67 | 69 | Output | LCD shift clock: This is the output pin for the segment external expansion display data shift clock. |
| | DO | 66 | 68 | Output | LCD serial data output: This is the output pin for segment external expansion serial display data. |
| | M | 65 | 67 | Output | LCD alternation signal: This is the output pin for the segment external expansion LCD alternation signal. |

2.1 Overview

The H8/300L CPU has sixteen 8-bit general registers, which can also be paired as eight 16-bit registers. Its concise instruction set is designed for high-speed operation.

2.1.1 Features

Features of the H8/300L CPU are listed below.

- General-register architecture
Sixteen 8-bit general registers, also usable as eight 16-bit general registers
- Instruction set with 55 basic instructions, including:
 - Multiply and divide instructions
 - Powerful bit-manipulation instructions
- Eight addressing modes
 - Register direct
 - Register indirect
 - Register indirect with displacement
 - Register indirect with post-increment or pre-decrement
 - Absolute address
 - Immediate
 - Program-counter relative
 - Memory indirect
- 64-kbyte address space
- High-speed operation
 - All frequently used instructions are executed in two to four states
 - High-speed arithmetic and logic operations
 - 8- or 16-bit register-register add or subtract: 0.67 μs^*
 - 8×8 -bit multiply: 4.67 μs^*
 - $16 \div 8$ -bit divide: 4.67 μs^*

Note: * These values are at $\phi = 3$ MHz.

- Low-power operation modes
SLEEP instruction for transfer to low-power operation

2.1.2 Address Space

The H8/300L CPU supports an address space of up to 64 kbytes for storing program code and data.

See 2.8, Memory Map, for details of the memory map.

2.1.3 Register Configuration

Figure 2.1 shows the register structure of the H8/300L CPU. There are two groups of registers: the general registers and control registers.

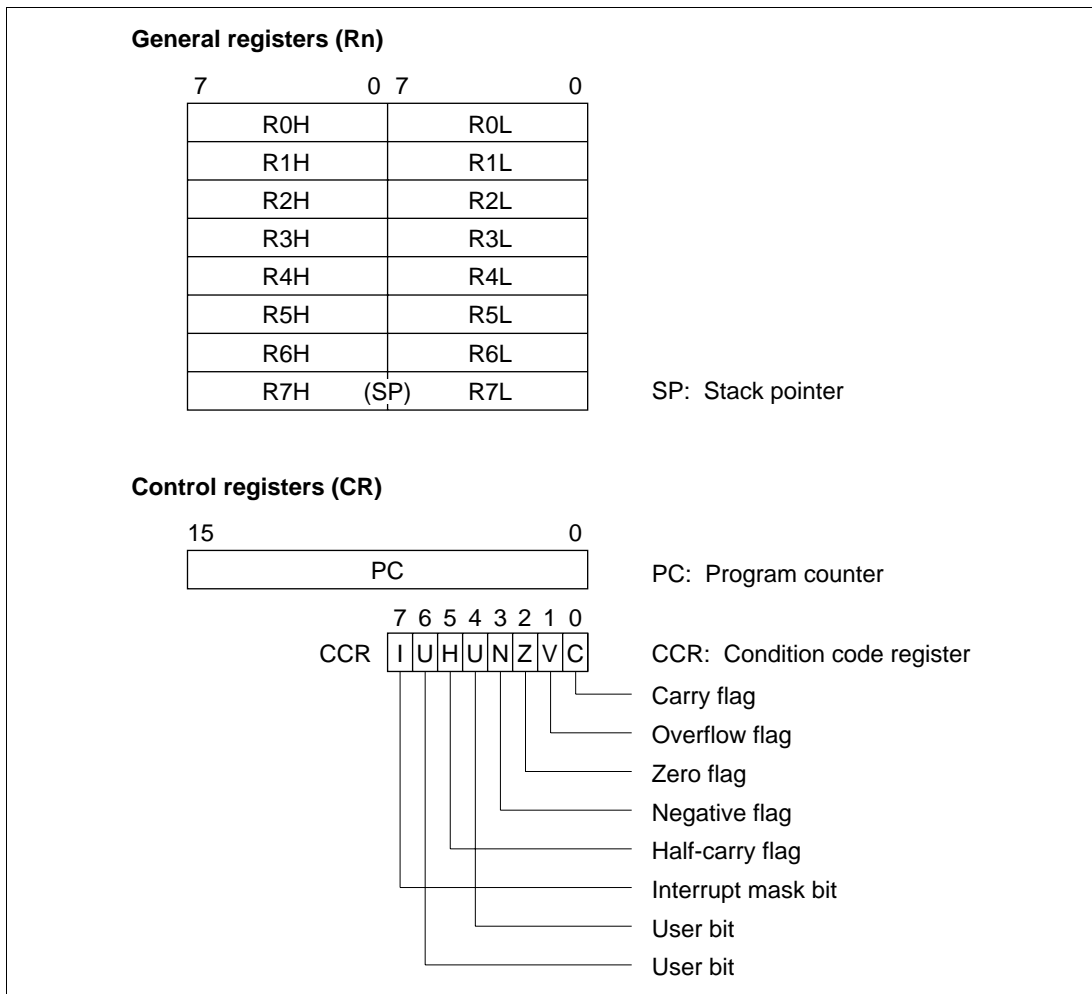

Figure 2.1 CPU Registers

2.2 Register Descriptions

2.2.1 General Registers

All the general registers can be used as both data registers and address registers.

When used as data registers, they can be accessed as 16-bit registers (R0 to R7), or the high bytes (R0H to R7H) and low bytes (R0L to R7L) can be accessed separately as 8-bit registers.

When used as address registers, the general registers are accessed as 16-bit registers (R0 to R7).

R7 also functions as the stack pointer (SP), used implicitly by hardware in exception processing and subroutine calls. When it functions as the stack pointer, as indicated in figure 2.2, SP (R7) points to the top of the stack.

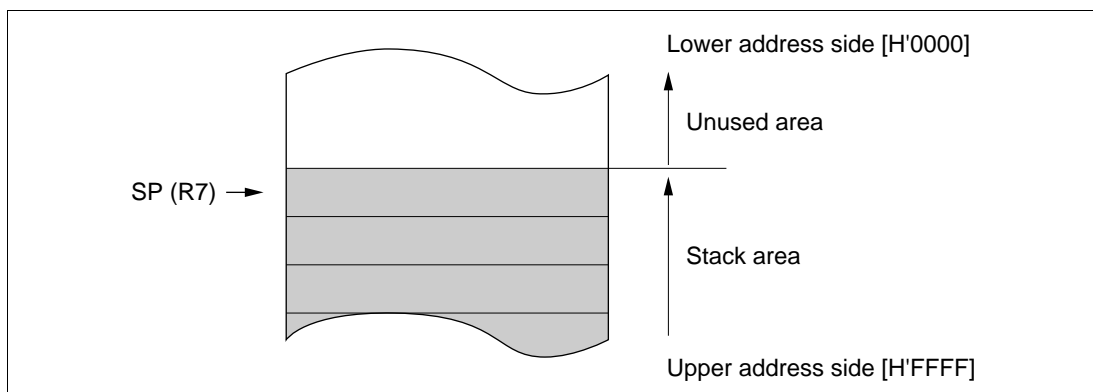

Figure 2.2 Stack Pointer

2.2.2 Control Registers

The CPU control registers include a 16-bit program counter (PC) and an 8-bit condition code register (CCR).

Program Counter (PC): This 16-bit register indicates the address of the next instruction the CPU will execute. All instructions are fetched 16 bits (1 word) at a time, so the least significant bit of the PC is ignored (always regarded as 0).

Condition Code Register (CCR): This 8-bit register contains internal status information, including the interrupt mask bit (I) and half-carry (H), negative (N), zero (Z), overflow (V), and carry (C) flags. These bits can be read and written by software (using the LDC, STC, ANDC, ORC, and XORC instructions). The N, Z, V, and C flags are used as branching conditions for conditional branching (Bcc) instructions.

Bit 7—Interrupt Mask Bit (I): When this bit is set to 1, interrupts are masked. This bit is set to 1 automatically at the start of exception handling. The interrupt mask bit may be read and written by software. For further details, see section 3.3, Interrupts.

Bit 6—User Bit (U): Can be used freely by the user.

Bit 5—Half-Carry Flag (H): When the ADD.B, ADDX.B, SUB.B, SUBX.B, CMP.B, or NEG.B instruction is executed, this flag is set to 1 if there is a carry or borrow at bit 3, and is cleared to 0 otherwise.

The H flag is used implicitly by the DAA and DAS instructions.

When the ADD.W, SUB.W, or CMP.W instruction is executed, the H flag is set to 1 if there is a carry or borrow at bit 11, and is cleared to 0 otherwise.

Bit 4—User Bit (U): Can be used freely by the user.

Bit 3—Negative Flag (N): Indicates the most significant bit (sign bit) of the result of an instruction.

Bit 2—Zero Flag (Z): Set to 1 to indicate a zero result, and cleared to 0 to indicate a non-zero result.

Bit 1—Overflow Flag (V): Set to 1 when an arithmetic overflow occurs, and cleared to 0 at other times.

Bit 0—Carry Flag (C): Set to 1 when a carry occurs, and cleared to 0 otherwise. Used by:

- Add instructions, to indicate a carry
- Subtract instructions, to indicate a borrow
- Shift and rotate instructions, to store the value shifted out of the end bit

The carry flag is also used as a bit accumulator by bit manipulation instructions.

Some instructions leave some or all of the flag bits unchanged.

Refer to the H8/300L Series Programming Manual for the action of each instruction on the flag bits.

2.2.3 Initial Register Values

When the CPU is reset, the program counter (PC) is initialized to the value stored at address H'0000 in the vector table, and the I bit in the CCR is set to 1. The other CCR bits and the general registers are not initialized. In particular, the stack pointer (R7) is not initialized. The stack pointer should be initialized by software, by the first instruction executed after a reset.

2.3 Data Formats

The H8/300L CPU can process 1-bit data, 4-bit (BCD) data, 8-bit (byte) data, and 16-bit (word) data.

- Bit manipulation instructions operate on 1-bit data specified as bit n in a byte operand ($n = 0, 1, 2, \dots, 7$).
- All arithmetic and logic instructions except ADDS and SUBS can operate on byte data.
- The MOV.W, ADD.W, SUB.W, CMP.W, ADDS, SUBS, MULXU (8 bits \times 8 bits), and DIVXU (16 bits \div 8 bits) instructions operate on word data.
- The DAA and DAS instructions perform decimal arithmetic adjustments on byte data in packed BCD form. Each nibble of the byte is treated as a decimal digit.

2.3.1 Data Formats in General Registers

Data of all the sizes above can be stored in general registers as shown in figure 2.3.

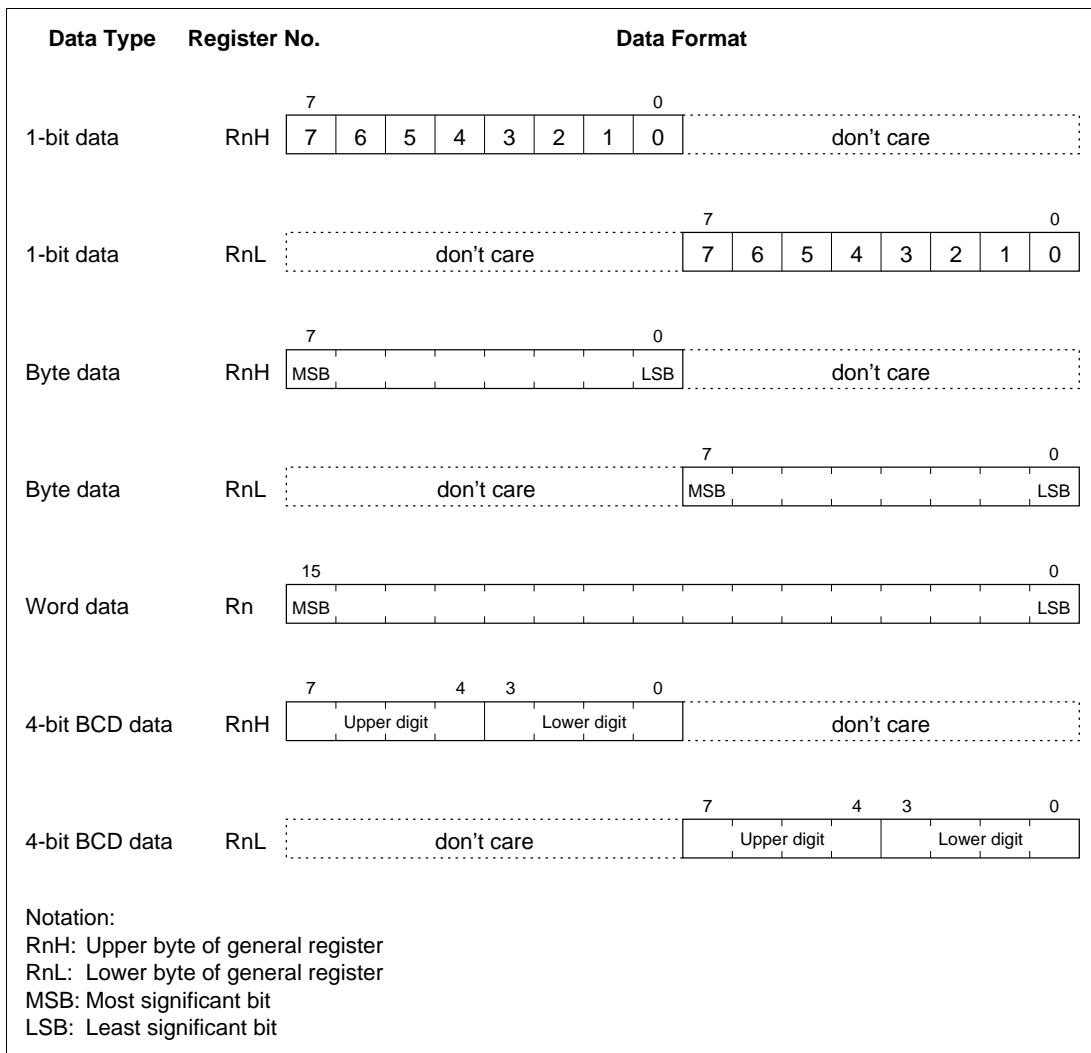

Figure 2.3 Register Data Formats

2.3.2 Memory Data Formats

Figure 2.4 indicates the data formats in memory. The H8/300L CPU can access word data stored in memory (MOV.W instruction), but the word data must always begin at an even address. If word data starting at an odd address is accessed, the least significant bit of the address is regarded as 0, and the word data starting at the preceding address is accessed. The same applies to instruction codes.

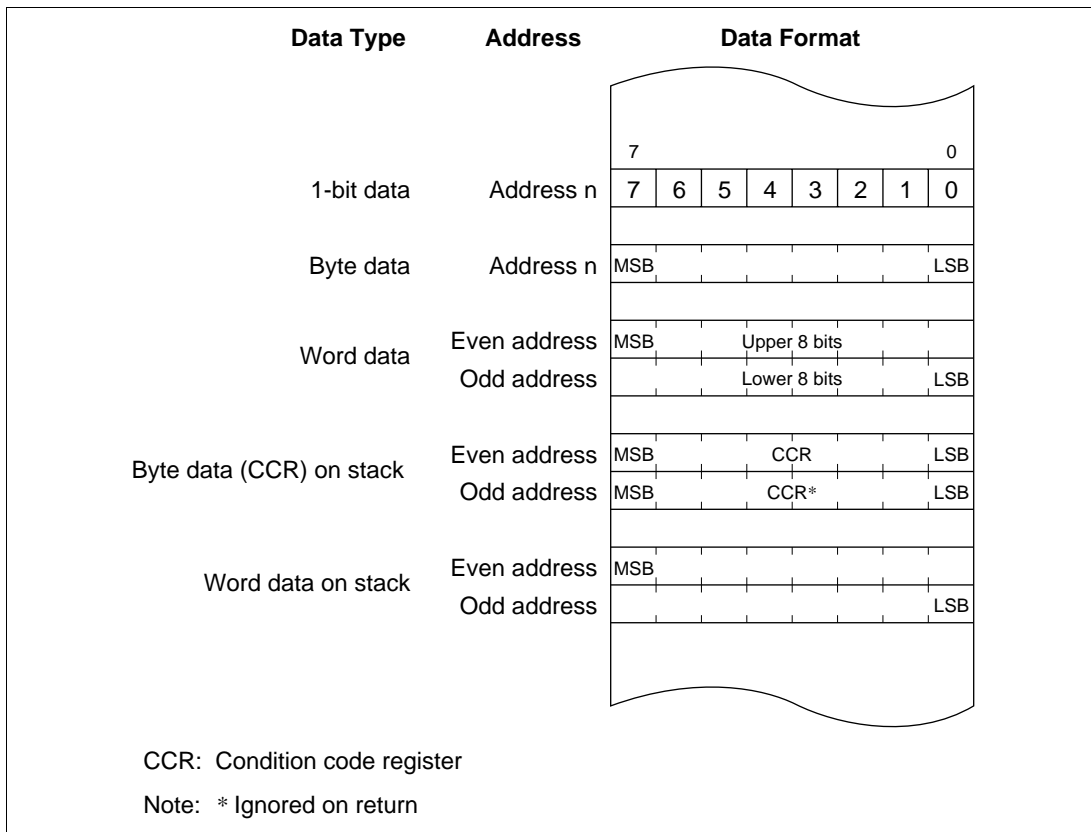

Figure 2.4 Memory Data Formats

When the stack is accessed using R7 as an address register, word access should always be performed. When the CCR is pushed on the stack, two identical copies of the CCR are pushed to make a complete word. When they are restored, the lower byte is ignored.

2.4 Addressing Modes

2.4.1 Addressing Modes

The H8/300L CPU supports the eight addressing modes listed in table 2.1. Each instruction uses a subset of these addressing modes.

Table 2.1 Addressing Modes

| No. | Address Modes | Symbol |
|-----|---|-----------------|
| 1 | Register direct | Rn |
| 2 | Register indirect | @Rn |
| 3 | Register indirect with displacement | @(d:16, Rn) |
| 4 | Register indirect with post-increment Register indirect with pre-decrement | @Rn+ @-Rn |
| 5 | Absolute address | @aa:8 or @aa:16 |
| 6 | Immediate | #xx:8 or #xx:16 |
| 7 | Program-counter relative | @(d:8, PC) |
| 8 | Memory indirect | @@aa:8 |

- 1. Register Direct—Rn:** The register field of the instruction specifies an 8- or 16-bit general register containing the operand.
Only the MOV.W, ADD.W, SUB.W, CMP.W, ADDS, SUBS, MULXU (8 bits × 8 bits), and DIVXU (16 bits ÷ 8 bits) instructions have 16-bit operands.
- 2. Register Indirect—@Rn:** The register field of the instruction specifies a 16-bit general register containing the address of the operand in memory.
- 3. Register Indirect with Displacement—@(d:16, Rn):** The instruction has a second word (bytes 3 and 4) containing a displacement which is added to the contents of the specified general register to obtain the operand address in memory.
This mode is used only in MOV instructions. For the MOV.W instruction, the resulting address must be even.

4. Register Indirect with Post-Increment or Pre-Decrement—@Rn+ or @-Rn:

— Register indirect with post-increment—@Rn+

The @Rn+ mode is used with MOV instructions that load registers from memory.

The register field of the instruction specifies a 16-bit general register containing the address of the operand. After the operand is accessed, the register is incremented by 1 for MOV.B or 2 for MOV.W. For MOV.W, the original contents of the 16-bit general register must be even.

— Register indirect with pre-decrement—@-Rn

The @-Rn mode is used with MOV instructions that store register contents to memory.

The register field of the instruction specifies a 16-bit general register which is decremented by 1 or 2 to obtain the address of the operand in memory. The register retains the decremented value. The size of the decrement is 1 for MOV.B or 2 for MOV.W. For MOV.W, the original contents of the register must be even.

5. Absolute Address—@aa:8 or @aa:16: The instruction specifies the absolute address of the operand in memory.

The absolute address may be 8 bits long (@aa:8) or 16 bits long (@aa:16). The MOV.B and bit manipulation instructions can use 8-bit absolute addresses. The MOV.B, MOV.W, JMP, and JSR instructions can use 16-bit absolute addresses.

For an 8-bit absolute address, the upper 8 bits are assumed to be 1 (H'FF). The address range is H'FF00 to H'FFFF (65280 to 65535).

6. Immediate—#xx:8 or #xx:16: The instruction contains an 8-bit operand (#xx:8) in its second byte, or a 16-bit operand (#xx:16) in its third and fourth bytes. Only MOV.W instructions can contain 16-bit immediate values.

The ADDS and SUBS instructions implicitly contain the value 1 or 2 as immediate data. Some bit manipulation instructions contain 3-bit immediate data in the second or fourth byte of the instruction, specifying a bit number.

7. Program-Counter Relative—@(d:8, PC): This mode is used in the Bcc and BSR instructions. An 8-bit displacement in byte 2 of the instruction code is sign-extended to 16 bits and added to the program counter contents to generate a branch destination address. The possible branching range is -126 to +128 bytes (-63 to +64 words) from the current address. The displacement should be an even number.

8. Memory Indirect—@@aa:8: This mode can be used by the JMP and JSR instructions. The second byte of the instruction code specifies an 8-bit absolute address. The word located at this address contains the branch destination address.

The upper 8 bits of the absolute address are assumed to be 0 (H'00), so the address range is from H'0000 to H'00FF (0 to 255). Note that with the H8/300L Series, the lower end of the address area is also used as a vector area. See 3.3, Interrupts, for details on the vector area.

If an odd address is specified as a branch destination or as the operand address of a MOV.W instruction, the least significant bit is regarded as 0, causing word access to be performed at the address preceding the specified address. See 2.3.2, Memory Data Formats, for further information.

2.4.2 Effective Address Calculation

Table 2.2 shows how effective addresses are calculated in each of the addressing modes.

Arithmetic and logic instructions use register direct addressing (1). The ADD.B, ADDX, SUBX, CMP.B, AND, OR, and XOR instructions can also use immediate addressing (6).

Data transfer instructions can use all addressing modes except program-counter relative (7) and memory indirect (8).

Bit manipulation instructions can use register direct (1), register indirect (2), or 8-bit absolute addressing (5) to specify the operand. Register indirect (1) (BSET, BCLR, BNOT, and BTST instructions) or 3-bit immediate addressing (6) can be used independently to specify a bit position in the operand.

Table 2.2 Effective Address Calculation

| No. | Addressing Mode and Instruction Format | Effective Address Calculation Method | Effective Address (EA) |
|-----|--|--|------------------------|
| 1 | Register direct, Rn <div style="display: flex; justify-content: space-between; align-items: center;"> <div style="border: 1px solid black; padding: 2px; margin-right: 10px;"> 15 op 8 7 4 3 0 rm rn </div> <div style="border: 1px solid black; padding: 2px; margin-right: 10px;"> 3 rm 0 3 </div> <div style="border: 1px solid black; padding: 2px;"> 3 rm </div> </div> | Operand is contents of registers indicated by rm/rm | |
| 2 | Register indirect, @Rn <div style="display: flex; justify-content: space-between; align-items: center;"> <div style="border: 1px solid black; padding: 2px; margin-right: 10px;"> 15 op 7 6 4 3 0 rm </div> <div style="border: 1px solid black; padding: 2px; margin-right: 10px;"> 15 Contents (16 bits) of register indicated by rm 0 </div> </div> | Operand is contents of registers indicated by rm/rm | |
| 3 | Register indirect with displacement, @(d:16, Rn) <div style="display: flex; justify-content: space-between; align-items: center;"> <div style="border: 1px solid black; padding: 2px; margin-right: 10px;"> 15 op 7 6 4 3 0 rm disp </div> <div style="border: 1px solid black; padding: 2px; margin-right: 10px;"> 15 Contents (16 bits) of register indicated by rm 0 + </div> <div style="border: 1px solid black; padding: 2px;"> 15 disp 0 </div> </div> | | |
| 4 | Register indirect with post-increment, @Rn+ <div style="display: flex; justify-content: space-between; align-items: center;"> <div style="border: 1px solid black; padding: 2px; margin-right: 10px;"> 15 op 7 6 4 3 0 rm </div> <div style="border: 1px solid black; padding: 2px; margin-right: 10px;"> 15 Contents (16 bits) of register indicated by rm 0 + </div> <div style="border: 1px solid black; padding: 2px; margin-right: 10px;"> 1 or 2 </div> </div> | | |
| | Register indirect with pre-decrement, @-Rn <div style="display: flex; justify-content: space-between; align-items: center;"> <div style="border: 1px solid black; padding: 2px; margin-right: 10px;"> 15 op 7 6 4 3 0 rm </div> <div style="border: 1px solid black; padding: 2px; margin-right: 10px;"> 15 Contents (16 bits) of register indicated by rm 0 - </div> <div style="border: 1px solid black; padding: 2px; margin-right: 10px;"> 1 or 2 </div> </div> | Incremented or decremented by 1 if operand is byte size, and by 2 if word size | |

Table 2.2 Effective Address Calculation (cont)

| No. | Addressing Mode and Instruction Format | Effective Address Calculation Method | Effective Address (EA) |
|-----|--|--------------------------------------|---|
| 5 | Absolute address @aa:8 | | |
| | @aa:16 | | |
| 6 | Immediate #xx:8 | | <p>Operand is 1- or 2-byte immediate data</p> |
| | #xx:16 | | |
| 7 | Program-counter relative @(d:8, PC) | | |

Table 2.2 Effective Address Calculation (cont)

| No. | Addressing Mode and Instruction Format | Effective Address Calculation Method | Effective Address (EA) |
|-----|--|--------------------------------------|------------------------|
|-----|--|--------------------------------------|------------------------|

8 Memory indirect, @aa:8

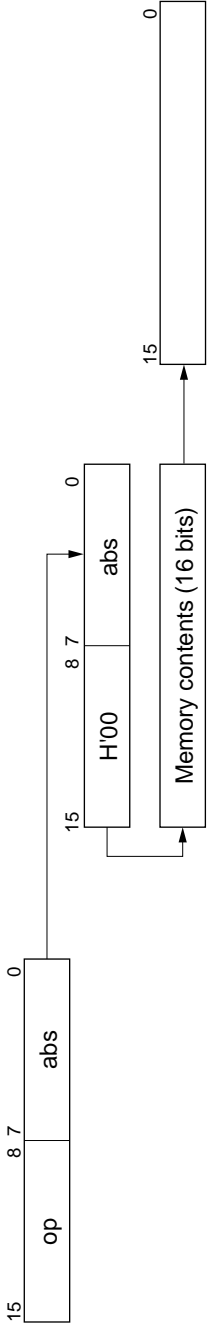

Notation:

- rm, r: Register field
- op: Operation field
- disp: Displacement
- IMM: Immediate data
- abs: Absolute address

2.5 Instruction Set

The H8/300L Series can use a total of 55 instructions, which are grouped by function in table 2.3.

Table 2.3 Instruction Set

| Function | Instructions | Number |
|-----------------------|---|-----------|
| Data transfer | MOV, PUSH ^{*1} , POP ^{*1} | 1 |
| Arithmetic operations | ADD, SUB, ADDX, SUBX, INC, DEC, ADDS, SUBS, DAA, DAS, MULXU, DIVXU, CMP, NEG | 14 |
| Logic operations | AND, OR, XOR, NOT | 4 |
| Shift | SHAL, SHAR, SHLL, SHLR, ROTL, ROTR, ROTXL, ROTXR | 8 |
| Bit manipulation | BSET, BCLR, BNOT, BTST, BAND, BIAND, BOR, BIOR, BXOR, BIXOR, BLD, BILD, BST, BIST | 14 |
| Branch | Bcc ^{*2} , JMP, BSR, JSR, RTS | 5 |
| System control | RTE, SLEEP, LDC, STC, ANDC, ORC, XORC, NOP | 8 |
| Block data transfer | EEPMOV | 1 |
| | | Total: 55 |

- Notes: 1. PUSH Rn is equivalent to MOV.W Rn, @-SP.
POP Rn is equivalent to MOV.W @SP+, Rn. The same applies to the machine language.
2. Bcc is a conditional branch instruction in which cc represents a condition code.

The following sections give a concise summary of the instructions in each category, and indicate the bit patterns of their object code. The notation used is defined next.

| Notation | |
|--------------|--|
| Rd | General register (destination) |
| Rs | General register (source) |
| Rn | General register |
| (EAd), <EAd> | Destination operand |
| (EAs), <EAs> | Source operand |
| CCR | Condition code register |
| N | N (negative) flag of CCR |
| Z | Z (zero) flag of CCR |
| V | V (overflow) flag of CCR |
| C | C (carry) flag of CCR |
| PC | Program counter |
| SP | Stack pointer |
| #IMM | Immediate data |
| disp | Displacement |
| + | Addition |
| - | Subtraction |
| × | Multiplication |
| ÷ | Division |
| ^ | AND logical |
| ∨ | OR logical |
| ⊕ | Exclusive OR logical |
| → | Move |
| ~ | Logical negation (logical complement) |
| :3 | 3-bit length |
| :8 | 8-bit length |
| :16 | 16-bit length |
| (), < > | Contents of operand indicated by effective address |

2.5.1 Data Transfer Instructions

Table 2.4 describes the data transfer instructions. Figure 2.5 shows their object code formats.

Table 2.4 Data Transfer Instructions

| Instruction | Size* | Function |
|--------------------|--------------|--|
| MOV | B/W | (EAs) → Rd, Rs → (EAd) Moves data between two general registers or between a general register and memory, or moves immediate data to a general register. The Rn, @Rn, @(d:16, Rn), @aa:16, #xx:16, @-Rn, and @Rn+ addressing modes are available for word data. The @aa:8 addressing mode is available for byte data only. The @-R7 and @R7+ modes require word operands. Do not specify byte size for these two modes. |
| POP | W | @SP+ → Rn Pops a 16-bit general register from the stack. Equivalent to MOV.W @SP+, Rn. |
| PUSH | W | Rn → @-SP Pushes a 16-bit general register onto the stack. Equivalent to MOV.W Rn, @-SP. |

Notes: * Size: Operand size
B: Byte
W: Word

Certain precautions are required in data access. See 2.9.1, Notes on Data Access, for details.

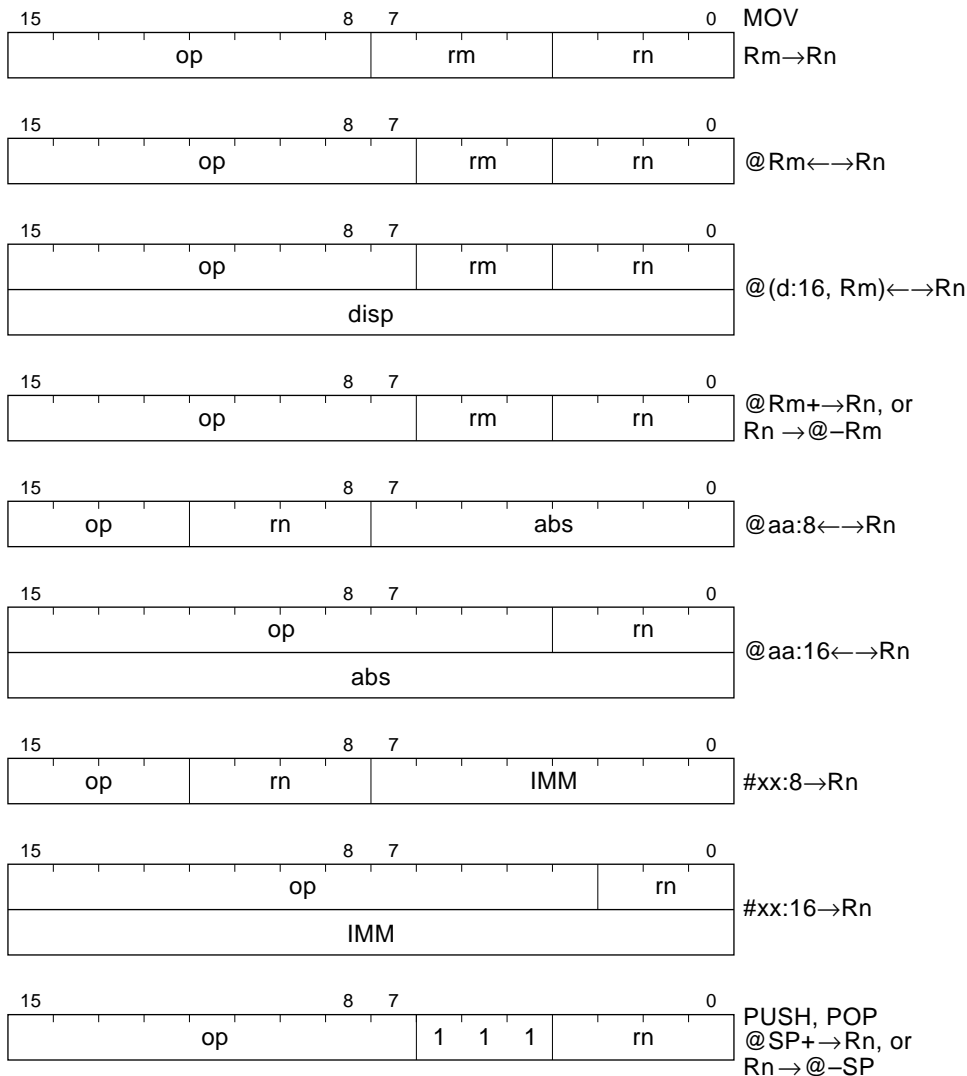

Notation:

- op: Operation field
- rm, rn: Register field
- disp: Displacement
- abs: Absolute address
- IMM: Immediate data

Figure 2.5 Data Transfer Instruction Codes

2.5.2 Arithmetic Operations

Table 2.5 describes the arithmetic instructions.

Table 2.5 Arithmetic Instructions

| Instruction | Size* | Function |
|--------------------|--------------|---|
| ADD SUB | B/W | $Rd \pm Rs \rightarrow Rd$, $Rd + \#IMM \rightarrow Rd$ Performs addition or subtraction on data in two general registers, or addition on immediate data and data in a general register. Immediate data cannot be subtracted from data in a general register. Word data can be added or subtracted only when both words are in general registers. |
| ADDX SUBX | B | $Rd \pm Rs \pm C \rightarrow Rd$, $Rd \pm \#IMM \pm C \rightarrow Rd$ Performs addition or subtraction with carry or borrow on byte data in two general registers, or addition or subtraction on immediate data and data in a general register. |
| INC DEC | B | $Rd \pm 1 \rightarrow Rd$ Increments or decrements a general register by 1. |
| ADDS SUBS | W | $Rd \pm 1 \rightarrow Rd$, $Rd \pm 2 \rightarrow Rd$ Adds or subtracts 1 or 2 to or from a general register |
| DAA DAS | B | Rd decimal adjust $\rightarrow Rd$ Decimal-adjusts (adjusts to 4-bit BCD) an addition or subtraction result in a general register by referring to the CCR |
| MULXU | B | $Rd \times Rs \rightarrow Rd$ Performs 8-bit \times 8-bit unsigned multiplication on data in two general registers, providing a 16-bit result |
| DIVXU | B | $Rd \div Rs \rightarrow Rd$ Performs 16-bit \div 8-bit unsigned division on data in two general registers, providing an 8-bit quotient and 8-bit remainder |
| CMP | B/W | $Rd - Rs$, $Rd - \#IMM$ Compares data in a general register with data in another general register or with immediate data, and indicates the result in the CCR. Word data can be compared only between two general registers. |
| NEG | B | $0 - Rd \rightarrow Rd$ Obtains the two's complement (arithmetic complement) of data in a general register |

Notes: * Size: Operand size

B: Byte

W: Word

2.5.3 Logic Operations

Table 2.6 describes the four instructions that perform logic operations.

Table 2.6 Logic Operation Instructions

| Instruction | Size* | Function |
|-------------|-------|--|
| AND | B | $Rd \wedge Rs \rightarrow Rd$, $Rd \wedge \#IMM \rightarrow Rd$ Performs a logical AND operation on a general register and another general register or immediate data |
| OR | B | $Rd \vee Rs \rightarrow Rd$, $Rd \vee \#IMM \rightarrow Rd$ Performs a logical OR operation on a general register and another general register or immediate data |
| XOR | B | $Rd \oplus Rs \rightarrow Rd$, $Rd \oplus \#IMM \rightarrow Rd$ Performs a logical exclusive OR operation on a general register and another general register or immediate data |
| NOT | B | $\sim Rd \rightarrow Rd$ Obtains the one's complement (logical complement) of general register contents |

Notes: * Size: Operand size
B: Byte

2.5.4 Shift Operations

Table 2.7 describes the eight shift instructions.

Table 2.7 Shift Instructions

| Instruction | Size* | Function |
|----------------|-------|---|
| SHAL SHAR | B | $Rd \text{ shift} \rightarrow Rd$ Performs an arithmetic shift operation on general register contents |
| SHLL SHLR | B | $Rd \text{ shift} \rightarrow Rd$ Performs a logical shift operation on general register contents |
| ROTL ROTR | B | $Rd \text{ rotate} \rightarrow Rd$ Rotates general register contents |
| ROTXL ROTXR | B | $Rd \text{ rotate through carry} \rightarrow Rd$ Rotates general register contents through the C (carry) bit |

Notes: * Size: Operand size
B: Byte

Figure 2.6 shows the instruction code format of arithmetic, logic, and shift instructions.

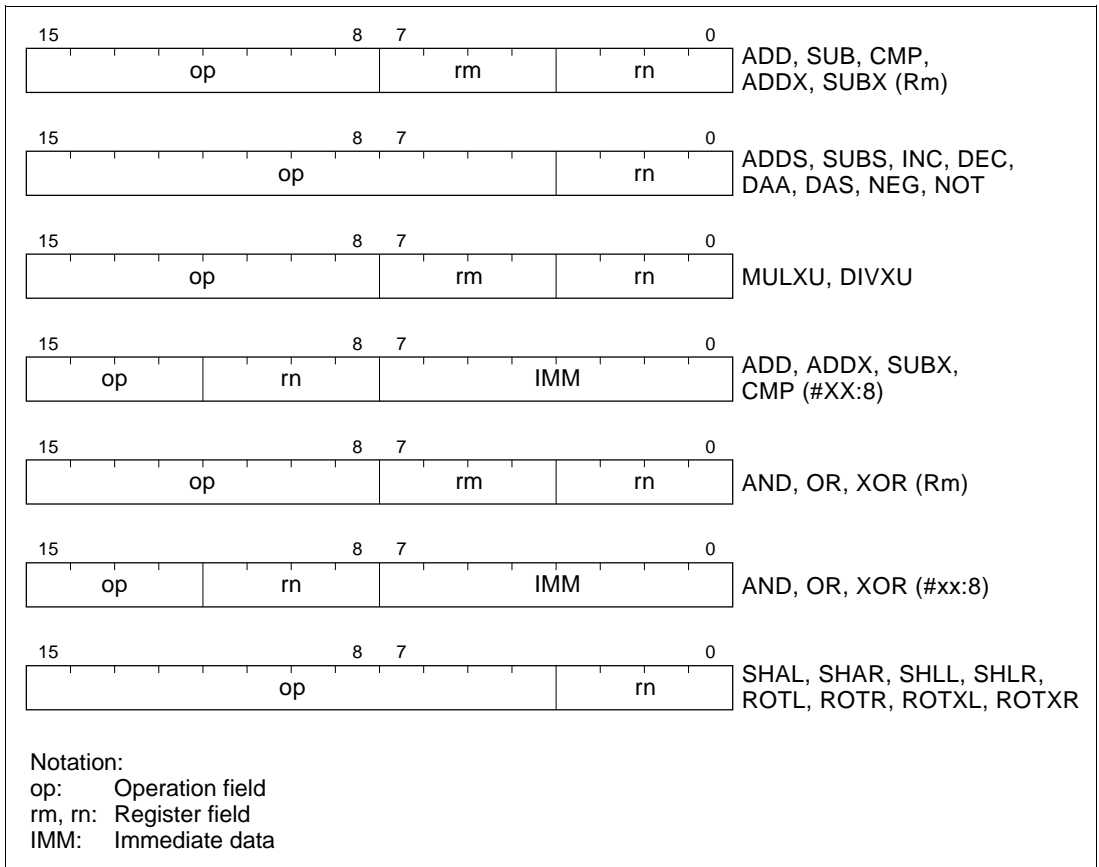

Figure 2.6 Arithmetic, Logic, and Shift Instruction Codes

2.5.5 Bit Manipulations

Table 2.8 describes the bit-manipulation instructions. Figure 2.7 shows their object code formats.

Table 2.8 Bit-Manipulation Instructions

| Instruction | Size* | Function |
|-------------|-------|---|
| BSET | B | $1 \rightarrow \langle \text{bit-No.} \rangle \text{ of } \langle \text{EAd} \rangle$ Sets a specified bit in a general register or memory to 1. The bit number is specified by 3-bit immediate data or the lower three bits of a general register. |
| BCLR | B | $0 \rightarrow \langle \text{bit-No.} \rangle \text{ of } \langle \text{EAd} \rangle$ Clears a specified bit in a general register or memory to 0. The bit number is specified by 3-bit immediate data or the lower three bits of a general register. |
| BNOT | B | $\sim \langle \text{bit-No.} \rangle \text{ of } \langle \text{EAd} \rangle \rightarrow \langle \text{bit-No.} \rangle \text{ of } \langle \text{EAd} \rangle$ Inverts a specified bit in a general register or memory. The bit number is specified by 3-bit immediate data or the lower three bits of a general register. |
| BTST | B | $\sim \langle \text{bit-No.} \rangle \text{ of } \langle \text{EAd} \rangle \rightarrow Z$ Tests a specified bit in a general register or memory and sets or clears the Z flag accordingly. The bit number is specified by 3-bit immediate data or the lower three bits of a general register. |
| BAND | B | $C \wedge \langle \text{bit-No.} \rangle \text{ of } \langle \text{EAd} \rangle \rightarrow C$ ANDs the C flag with a specified bit in a general register or memory, and stores the result in the C flag. |
| BIAND | B | $C \wedge [\sim \langle \text{bit-No.} \rangle \text{ of } \langle \text{EAd} \rangle] \rightarrow C$ ANDs the C flag with the inverse of a specified bit in a general register or memory, and stores the result in the C flag. The bit number is specified by 3-bit immediate data. |
| BOR | B | $C \vee \langle \text{bit-No.} \rangle \text{ of } \langle \text{EAd} \rangle \rightarrow C$ ORs the C flag with a specified bit in a general register or memory, and stores the result in the C flag. |
| BIOR | B | $C \vee [\sim \langle \text{bit-No.} \rangle \text{ of } \langle \text{EAd} \rangle] \rightarrow C$ ORs the C flag with the inverse of a specified bit in a general register or memory, and stores the result in the C flag. The bit number is specified by 3-bit immediate data. |

Notes: * Size: Operand size
 B: Byte

Table 2.8 Bit-Manipulation Instructions (cont)

| Instruction | Size* | Function |
|--------------------|--------------|--|
| BXOR | B | $C \oplus (\text{<bit-No.> of <EAd>}) \rightarrow C$ XORs the C flag with a specified bit in a general register or memory, and stores the result in the C flag. |
| BIXOR | B | $C \oplus [-(\text{<bit-No.> of <EAd>})] \rightarrow C$ XORs the C flag with the inverse of a specified bit in a general register or memory, and stores the result in the C flag. The bit number is specified by 3-bit immediate data. |
| BLD | B | $(\text{<bit-No.> of <EAd>}) \rightarrow C$ Copies a specified bit in a general register or memory to the C flag. |
| BILD | B | $\sim (\text{<bit-No.> of <EAd>}) \rightarrow C$ Copies the inverse of a specified bit in a general register or memory to the C flag. The bit number is specified by 3-bit immediate data. |
| BST | B | $C \rightarrow (\text{<bit-No.> of <EAd>})$ Copies the C flag to a specified bit in a general register or memory. |
| BIST | B | $\sim C \rightarrow (\text{<bit-No.> of <EAd>})$ Copies the inverse of the C flag to a specified bit in a general register or memory. The bit number is specified by 3-bit immediate data. |

Notes: * Size: Operand size
 B: Byte

Certain precautions are required in bit manipulation. See 2.9.2, Notes on Bit Manipulation, for details.

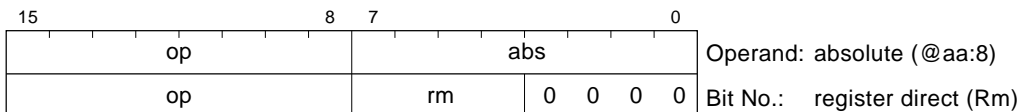
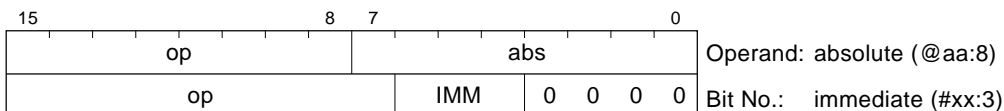
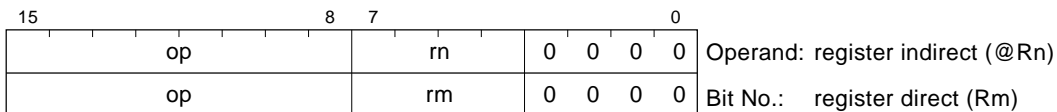
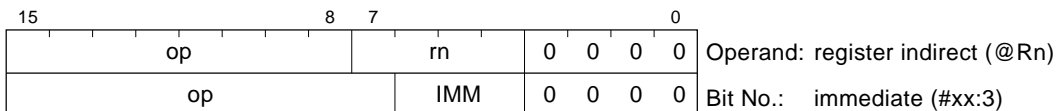
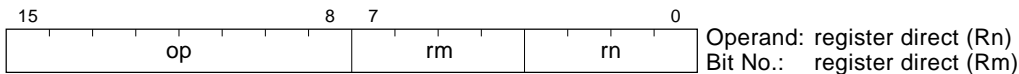
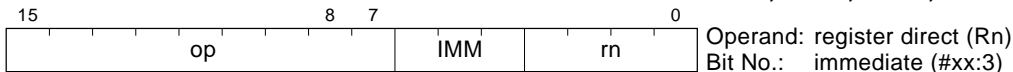
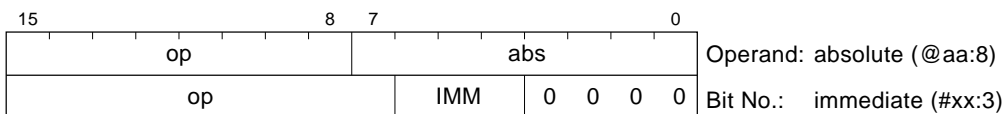
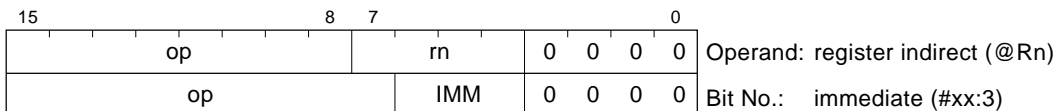
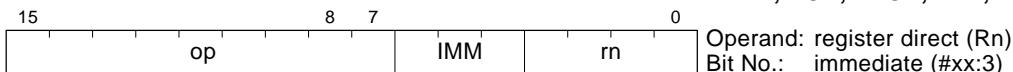
BSET, BCLR, BNOT, BTST**BAND, BOR, BXOR, BLD, BST****Notation:**

op: Operation field
rm, rn: Register field
abs: Absolute address
IMM: Immediate data

Figure 2.7 Bit Manipulation Instruction Codes

BIAND, BIOR, BIXOR, BILD, BIST

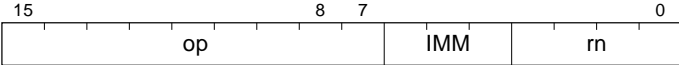

Operand: register direct (Rn)
Bit No.: immediate (#xx:3)

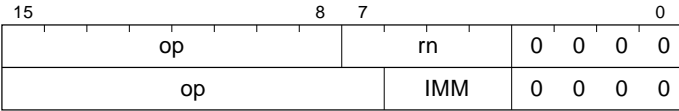

Operand: register indirect (@Rn)
Bit No.: immediate (#xx:3)

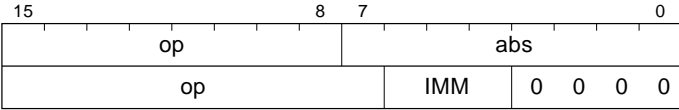

Operand: absolute (@aa:8)
Bit No.: immediate (#xx:3)

Notation:

- op: Operation field
- rm, rn: Register field
- abs: Absolute address
- IMM: Immediate data

Figure 2.7 Bit Manipulation Instruction Codes (cont)

2.5.6 Branching Instructions

Table 2.9 describes the branching instructions. Figure 2.8 shows their object code formats.

Table 2.9 Branching Instructions

| Instruction | Size | Function | | | | | | | | | | | | | | | | | | | | | | | | | | | | | | | | | | | | | | | | | | | | | | | | | | | |
|-------------|----------------------------|--|----------|-------------|-----------|----------|---------------|--------|----------|---------------|-------|-----|------|----------------|-----|-------------|----------------|-----------|----------------------------|---------|-----------|-----------------|---------|-----|-----------|---------|-----|-------|---------|-----|----------------|---------|-----|--------------|---------|-----|------|---------|-----|-------|---------|-----|------------------|------------------|-----|-----------|------------------|-----|--------------|---------------------------|-----|---------------|---------------------------|
| Bcc | — | Branches to the designated address if condition cc is true. The branching conditions are given below. | | | | | | | | | | | | | | | | | | | | | | | | | | | | | | | | | | | | | | | | | | | | | | | | | | | |
| | | <table border="1"> <thead> <tr> <th>Mnemonic</th> <th>Description</th> <th>Condition</th> </tr> </thead> <tbody> <tr> <td>BRA (BT)</td> <td>Always (true)</td> <td>Always</td> </tr> <tr> <td>BRN (BF)</td> <td>Never (false)</td> <td>Never</td> </tr> <tr> <td>BHI</td> <td>High</td> <td>$C \vee Z = 0$</td> </tr> <tr> <td>BLS</td> <td>Low or same</td> <td>$C \vee Z = 1$</td> </tr> <tr> <td>BCC (BHS)</td> <td>Carry clear (high or same)</td> <td>$C = 0$</td> </tr> <tr> <td>BCS (BLO)</td> <td>Carry set (low)</td> <td>$C = 1$</td> </tr> <tr> <td>BNE</td> <td>Not equal</td> <td>$Z = 0$</td> </tr> <tr> <td>BEQ</td> <td>Equal</td> <td>$Z = 1$</td> </tr> <tr> <td>BVC</td> <td>Overflow clear</td> <td>$V = 0$</td> </tr> <tr> <td>BVS</td> <td>Overflow set</td> <td>$V = 1$</td> </tr> <tr> <td>BPL</td> <td>Plus</td> <td>$N = 0$</td> </tr> <tr> <td>BMI</td> <td>Minus</td> <td>$N = 1$</td> </tr> <tr> <td>BGE</td> <td>Greater or equal</td> <td>$N \oplus V = 0$</td> </tr> <tr> <td>BLT</td> <td>Less than</td> <td>$N \oplus V = 1$</td> </tr> <tr> <td>BGT</td> <td>Greater than</td> <td>$Z \vee (N \oplus V) = 0$</td> </tr> <tr> <td>BLE</td> <td>Less or equal</td> <td>$Z \vee (N \oplus V) = 1$</td> </tr> </tbody> </table> | Mnemonic | Description | Condition | BRA (BT) | Always (true) | Always | BRN (BF) | Never (false) | Never | BHI | High | $C \vee Z = 0$ | BLS | Low or same | $C \vee Z = 1$ | BCC (BHS) | Carry clear (high or same) | $C = 0$ | BCS (BLO) | Carry set (low) | $C = 1$ | BNE | Not equal | $Z = 0$ | BEQ | Equal | $Z = 1$ | BVC | Overflow clear | $V = 0$ | BVS | Overflow set | $V = 1$ | BPL | Plus | $N = 0$ | BMI | Minus | $N = 1$ | BGE | Greater or equal | $N \oplus V = 0$ | BLT | Less than | $N \oplus V = 1$ | BGT | Greater than | $Z \vee (N \oplus V) = 0$ | BLE | Less or equal | $Z \vee (N \oplus V) = 1$ |
| Mnemonic | Description | Condition | | | | | | | | | | | | | | | | | | | | | | | | | | | | | | | | | | | | | | | | | | | | | | | | | | | |
| BRA (BT) | Always (true) | Always | | | | | | | | | | | | | | | | | | | | | | | | | | | | | | | | | | | | | | | | | | | | | | | | | | | |
| BRN (BF) | Never (false) | Never | | | | | | | | | | | | | | | | | | | | | | | | | | | | | | | | | | | | | | | | | | | | | | | | | | | |
| BHI | High | $C \vee Z = 0$ | | | | | | | | | | | | | | | | | | | | | | | | | | | | | | | | | | | | | | | | | | | | | | | | | | | |
| BLS | Low or same | $C \vee Z = 1$ | | | | | | | | | | | | | | | | | | | | | | | | | | | | | | | | | | | | | | | | | | | | | | | | | | | |
| BCC (BHS) | Carry clear (high or same) | $C = 0$ | | | | | | | | | | | | | | | | | | | | | | | | | | | | | | | | | | | | | | | | | | | | | | | | | | | |
| BCS (BLO) | Carry set (low) | $C = 1$ | | | | | | | | | | | | | | | | | | | | | | | | | | | | | | | | | | | | | | | | | | | | | | | | | | | |
| BNE | Not equal | $Z = 0$ | | | | | | | | | | | | | | | | | | | | | | | | | | | | | | | | | | | | | | | | | | | | | | | | | | | |
| BEQ | Equal | $Z = 1$ | | | | | | | | | | | | | | | | | | | | | | | | | | | | | | | | | | | | | | | | | | | | | | | | | | | |
| BVC | Overflow clear | $V = 0$ | | | | | | | | | | | | | | | | | | | | | | | | | | | | | | | | | | | | | | | | | | | | | | | | | | | |
| BVS | Overflow set | $V = 1$ | | | | | | | | | | | | | | | | | | | | | | | | | | | | | | | | | | | | | | | | | | | | | | | | | | | |
| BPL | Plus | $N = 0$ | | | | | | | | | | | | | | | | | | | | | | | | | | | | | | | | | | | | | | | | | | | | | | | | | | | |
| BMI | Minus | $N = 1$ | | | | | | | | | | | | | | | | | | | | | | | | | | | | | | | | | | | | | | | | | | | | | | | | | | | |
| BGE | Greater or equal | $N \oplus V = 0$ | | | | | | | | | | | | | | | | | | | | | | | | | | | | | | | | | | | | | | | | | | | | | | | | | | | |
| BLT | Less than | $N \oplus V = 1$ | | | | | | | | | | | | | | | | | | | | | | | | | | | | | | | | | | | | | | | | | | | | | | | | | | | |
| BGT | Greater than | $Z \vee (N \oplus V) = 0$ | | | | | | | | | | | | | | | | | | | | | | | | | | | | | | | | | | | | | | | | | | | | | | | | | | | |
| BLE | Less or equal | $Z \vee (N \oplus V) = 1$ | | | | | | | | | | | | | | | | | | | | | | | | | | | | | | | | | | | | | | | | | | | | | | | | | | | |
| JMP | — | Branches unconditionally to a specified address | | | | | | | | | | | | | | | | | | | | | | | | | | | | | | | | | | | | | | | | | | | | | | | | | | | |
| BSR | — | Branches to a subroutine at a specified address | | | | | | | | | | | | | | | | | | | | | | | | | | | | | | | | | | | | | | | | | | | | | | | | | | | |
| JSR | — | Branches to a subroutine at a specified address | | | | | | | | | | | | | | | | | | | | | | | | | | | | | | | | | | | | | | | | | | | | | | | | | | | |
| RTS | — | Returns from a subroutine | | | | | | | | | | | | | | | | | | | | | | | | | | | | | | | | | | | | | | | | | | | | | | | | | | | |

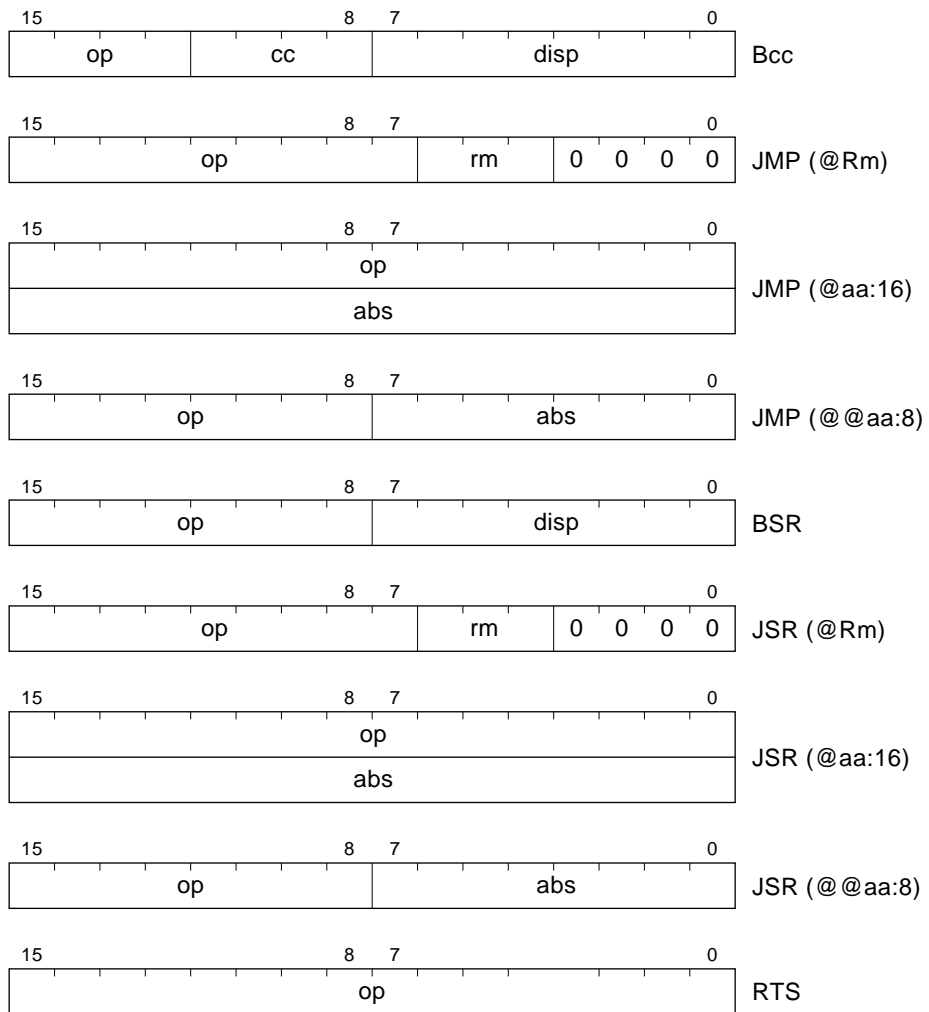

Notation:
op: Operation field
cc: Condition field
rm: Register field
disp: Displacement
abs: Absolute address

Figure 2.8 Branching Instruction Codes

2.5.7 System Control Instructions

Table 2.10 describes the system control instructions. Figure 2.9 shows their object code formats.

Table 2.10 System Control Instructions

| Instruction | Size* | Function |
|--------------------|--------------|---|
| RTE | — | Returns from an exception-handling routine |
| SLEEP | — | Causes a transition from active mode to a power-down mode. See section 5, Power-Down Modes, for details. |
| LDC | B | $R_s \rightarrow CCR$, $\#IMM \rightarrow CCR$ Moves immediate data or general register contents to the condition code register |
| STC | B | $CCR \rightarrow R_d$ Copies the condition code register to a specified general register |
| ANDC | B | $CCR \wedge \#IMM \rightarrow CCR$ Logically ANDs the condition code register with immediate data |
| ORC | B | $CCR \vee \#IMM \rightarrow CCR$ Logically ORs the condition code register with immediate data |
| XORC | B | $CCR \oplus \#IMM \rightarrow CCR$ Logically exclusive-ORs the condition code register with immediate data |
| NOP | — | $PC + 2 \rightarrow PC$ Only increments the program counter |

Notes: * Size: Operand size
B: Byte

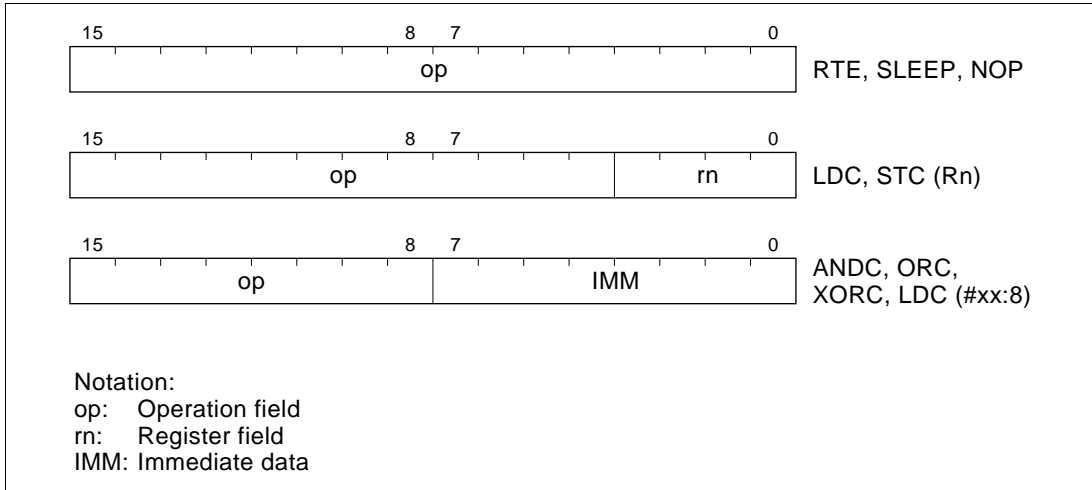

Figure 2.9 System Control Instruction Codes

2.5.8 Block Data Transfer Instruction

Table 2.11 describes the block data transfer instruction. Figure 2.10 shows its object code format.

Table 2.11 Block Data Transfer Instruction

| Instruction | Size | Function |
|-------------|------|---|
| EEPMOV | — | <p>If R4L = 0 then</p> <p>repeat @R5+ → @R6+ R4L – 1 → R4L</p> <p>until R4L = 0</p> <p>else next;</p> <p>Block transfer instruction. Transfers the number of data bytes specified by R4L from locations starting at the address indicated by R5 to locations starting at the address indicated by R6. After the transfer, the next instruction is executed.</p> |

Certain precautions are required in using the EEPMOV instruction. See 2.9.3, Notes on Use of the EEPMOV Instruction, for details.

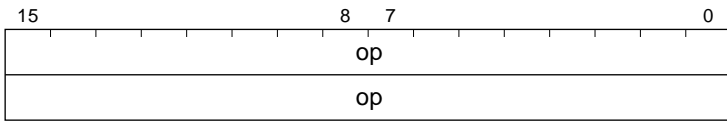

Notation:
op: Operation field

Figure 2.10 Block Data Transfer Instruction Code

2.6 Basic Operational Timing

CPU operation is synchronized by a system clock (ϕ) or a subclock (ϕ_{SUB}). For details on these clock signals see section 4, Clock Pulse Generators. The period from a rising edge of ϕ or ϕ_{SUB} to the next rising edge is called one state. A bus cycle consists of two states or three states. The cycle differs depending on whether access is to on-chip memory or to on-chip peripheral modules.

2.6.1 Access to On-Chip Memory (RAM, ROM)

Access to on-chip memory takes place in two states. The data bus width is 16 bits, allowing access in byte or word size. Figure 2.11 shows the on-chip memory access cycle.

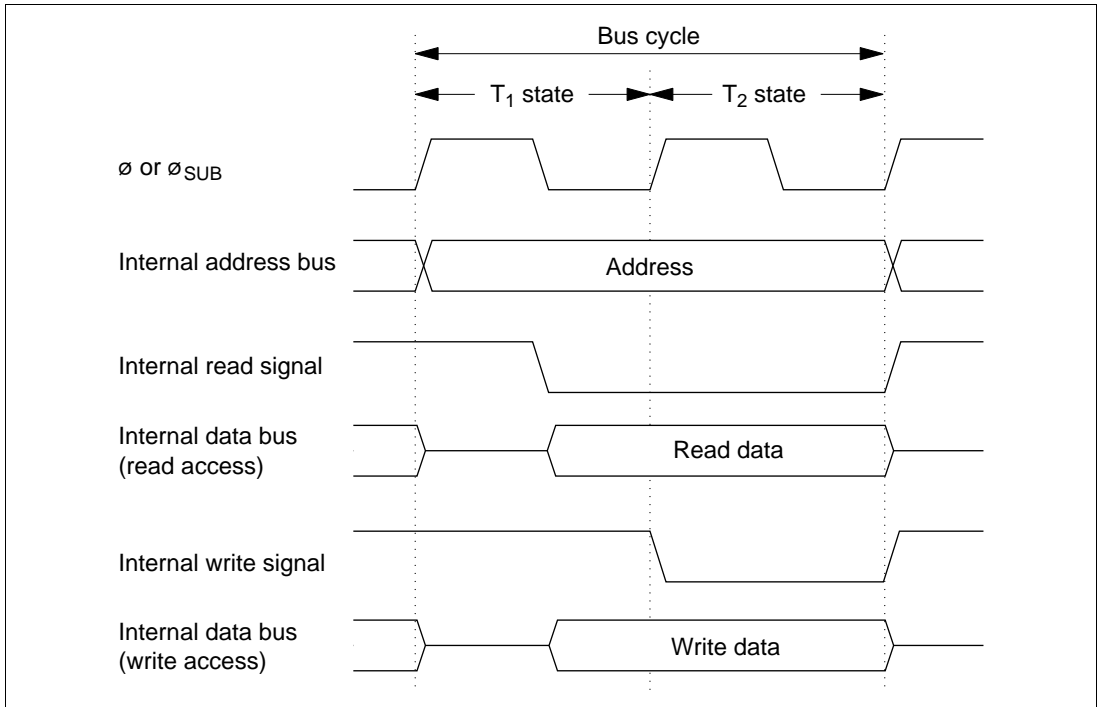

Figure 2.11 On-Chip Memory Access Cycle

2.6.2 Access to On-Chip Peripheral Modules

On-chip peripheral modules are accessed in two states or three states. The data bus width is 8 bits, so access is by byte size only. This means that for accessing word data, two instructions must be used. Figures 2.12 and 2.13 show the on-chip peripheral module access cycle.

Two-state access to on-chip peripheral modules

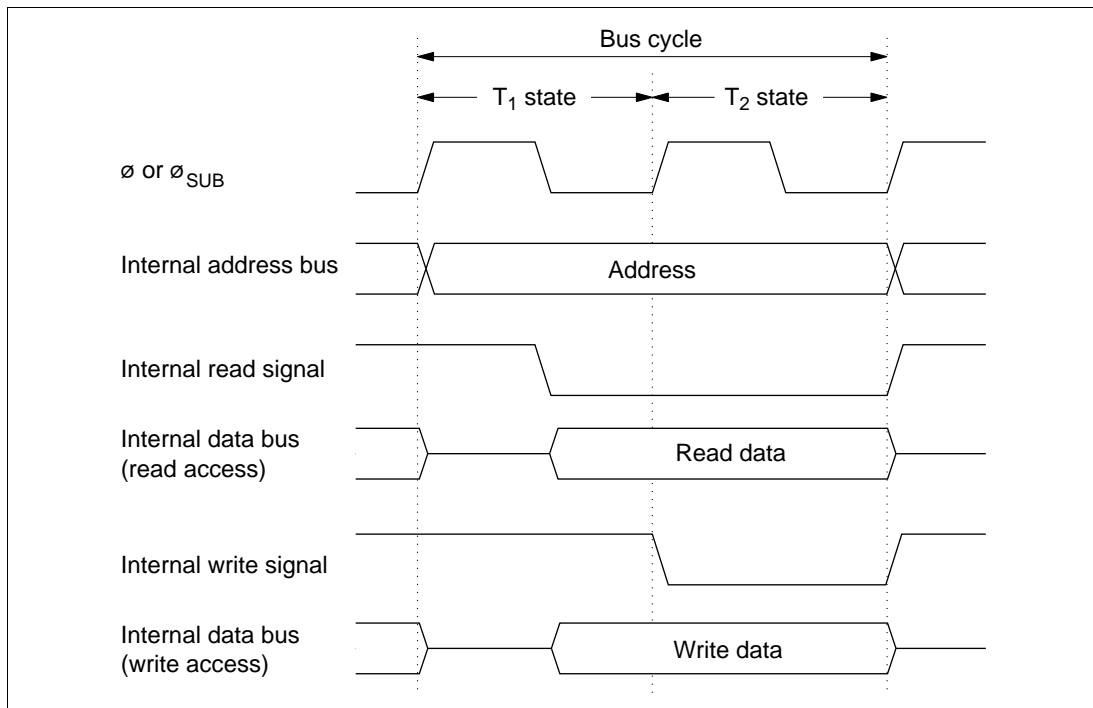

Figure 2.12 On-Chip Peripheral Module Access Cycle (2-State Access)

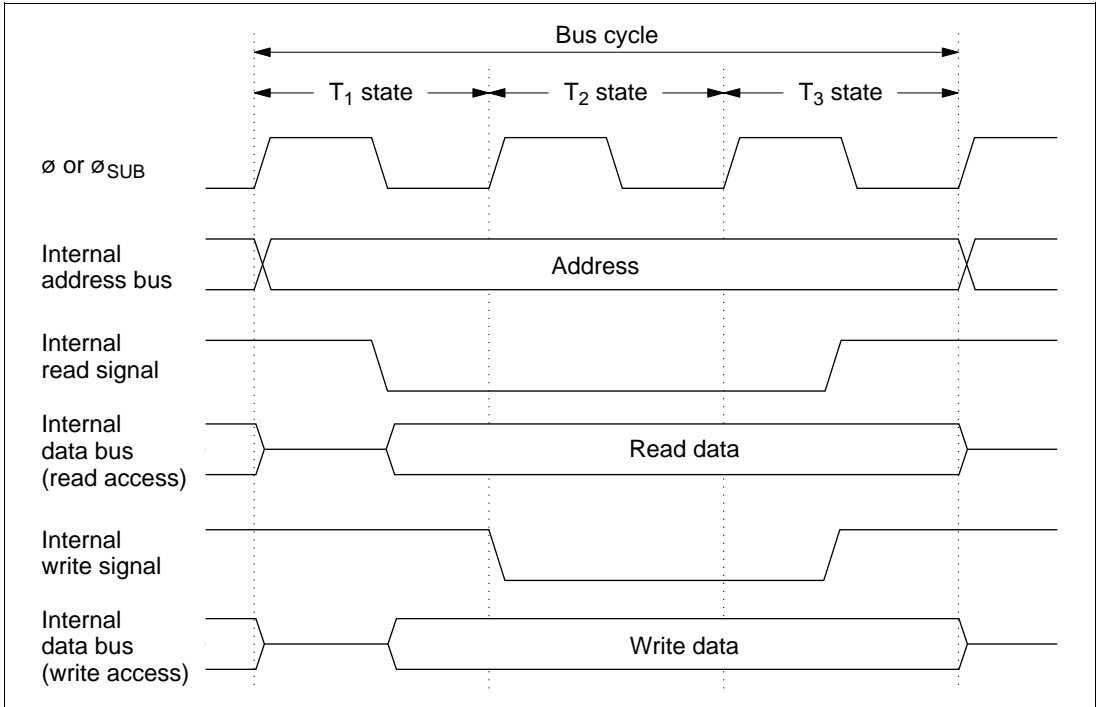

Figure 2.13 On-Chip Peripheral Module Access Cycle (3-State Access)

2.7 CPU States

2.7.1 Overview

There are four CPU states: the reset state, program execution state, program halt state, and exception-handling state. The program execution state includes active (high-speed or medium-speed) mode and subactive mode. In the program halt state there are a sleep (high-speed or medium-speed) mode, standby mode, watch mode, and sub-sleep mode. These states are shown in figure 2.14. Figure 2.15 shows the state transitions.

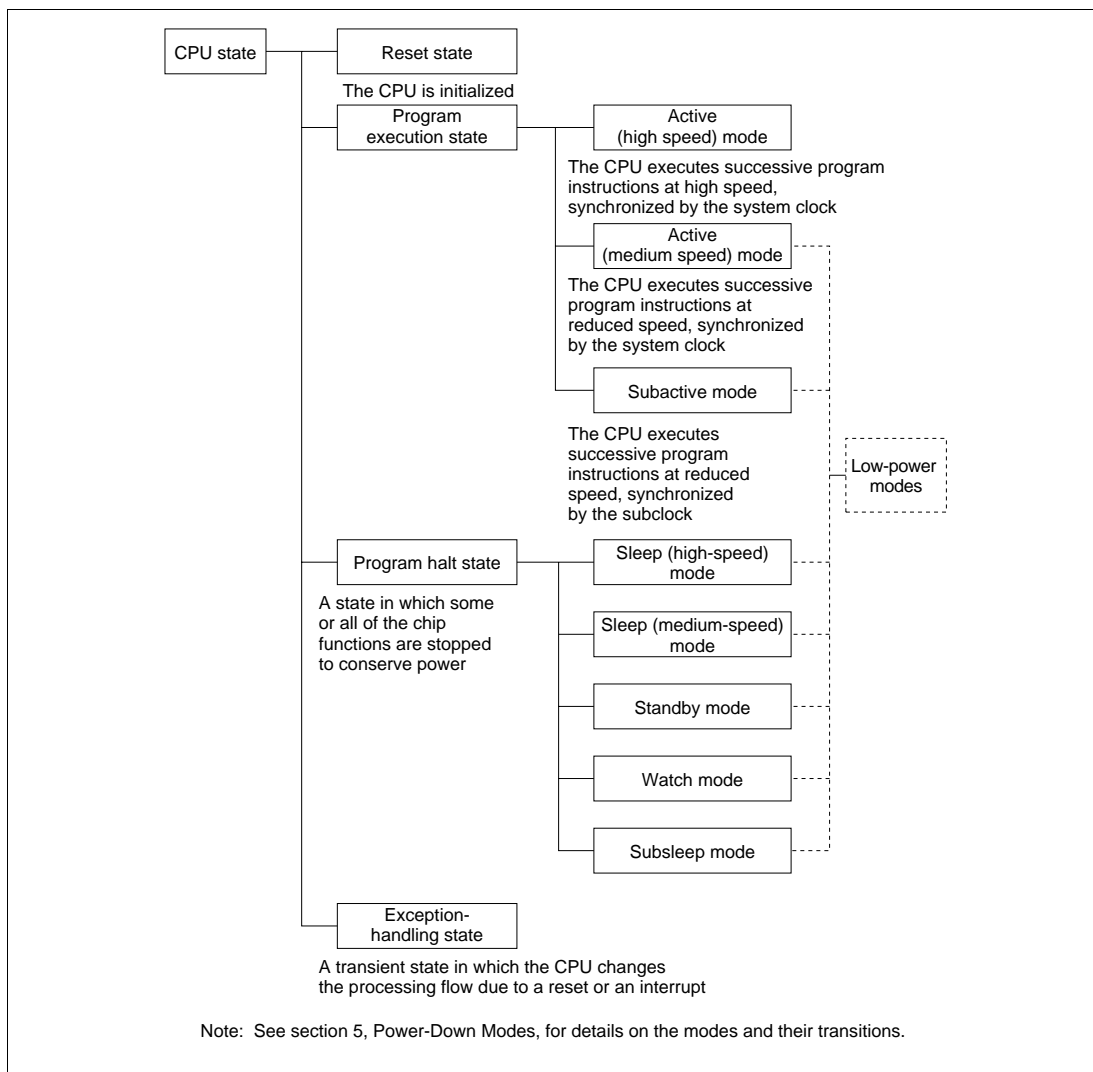

Figure 2.14 CPU Operation States

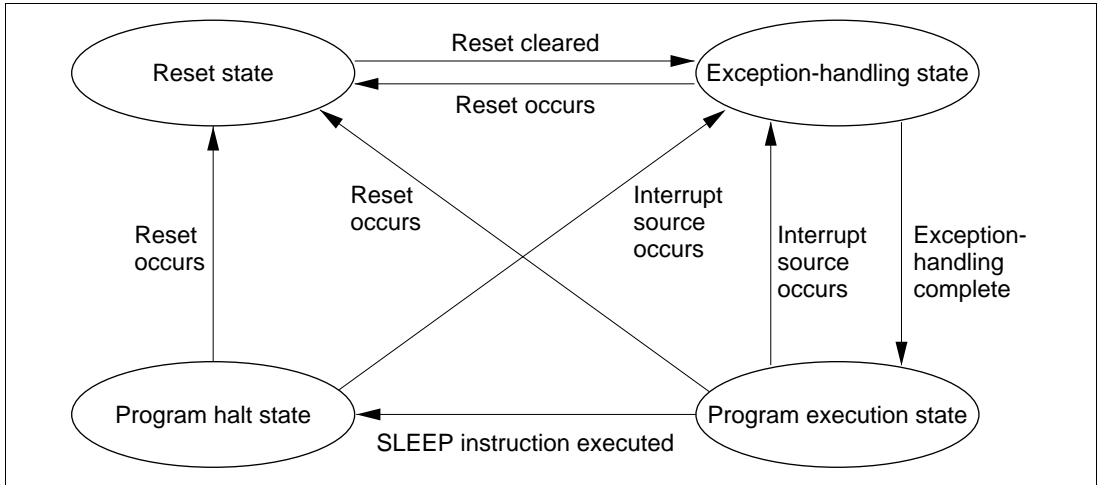

Figure 2.15 State Transitions

2.7.2 Program Execution State

In the program execution state the CPU executes program instructions in sequence.

There are three modes in this state, two active modes (high speed and medium speed) and one subactive mode. Operation is synchronized with the system clock in active mode (high speed and medium speed), and with the subclock in subactive mode. See section 5, Power-Down Modes for details on these modes.

2.7.3 Program Halt State

In the program halt state there are five modes: two sleep modes (high speed and medium speed), standby mode, watch mode, and subsleep mode. See section 5, Power-Down Modes for details on these modes.

2.7.4 Exception-Handling State

The exception-handling state is a transient state occurring when exception handling is started by a reset or interrupt and the CPU changes its normal processing flow. In exception handling caused by an interrupt, SP (R7) is referenced and the PC and CCR values are saved on the stack.

For details on interrupt handling, see section 3.3, Interrupts.

2.8 Memory Map

2.8.1 Memory Map

The memory map of the H8/3862 and H8/3822 is shown in figure 2.16 (1), that of the H8/3863 and H8/3823 in figure 2.16 (2), that of the H8/3864 and H8/3824 in figure 2.16 (3), that of the H8/3865 and H8/3825 in figure 2.16 (4), that of the H8/3866 and H8/3826 in figure 2.16 (5), and that of the H8/3867 and H8/3827 in figure 2.16 (6).

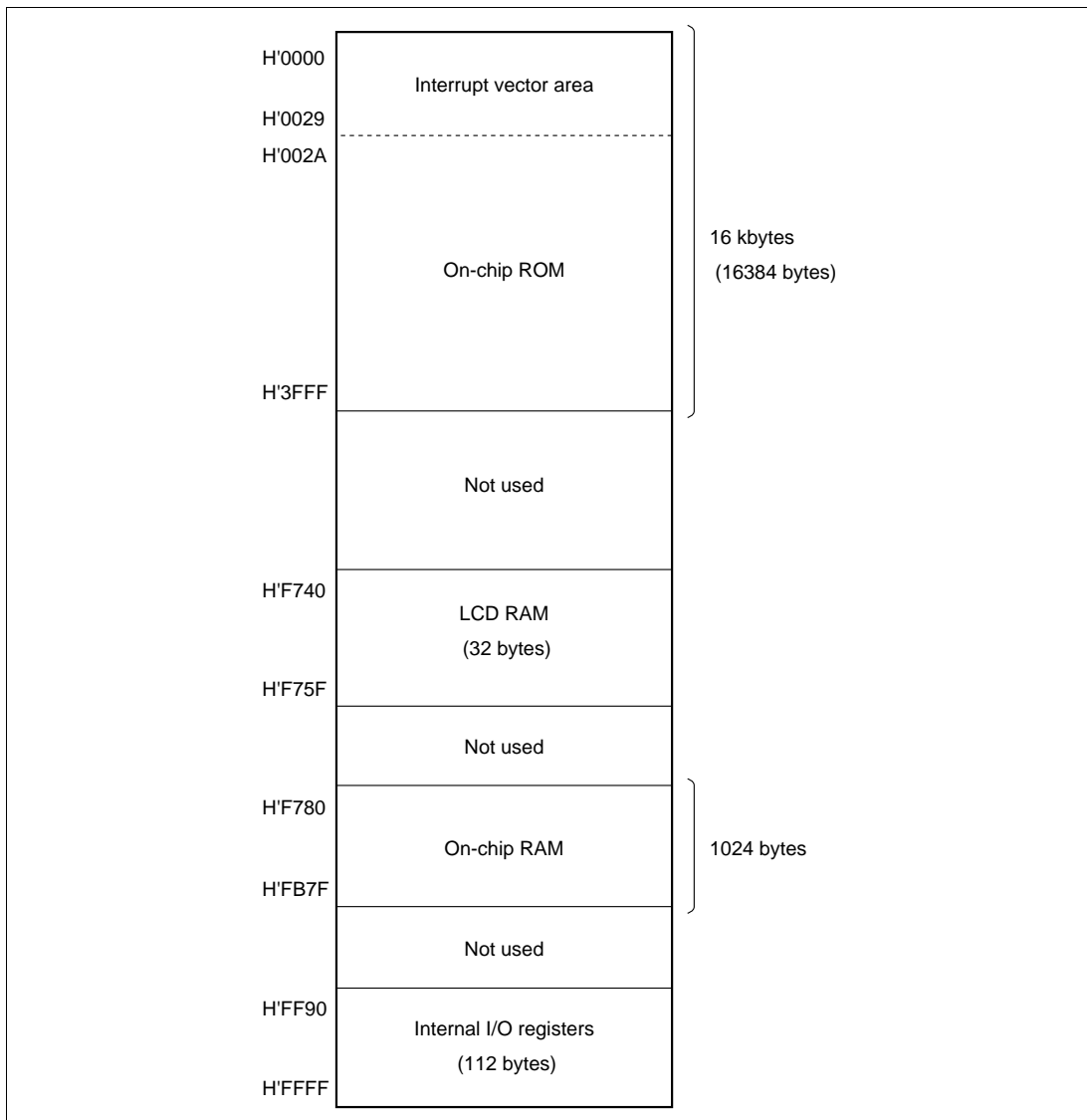

Figure 2.16 (1) H8/3862 and H8/3822 Memory Map

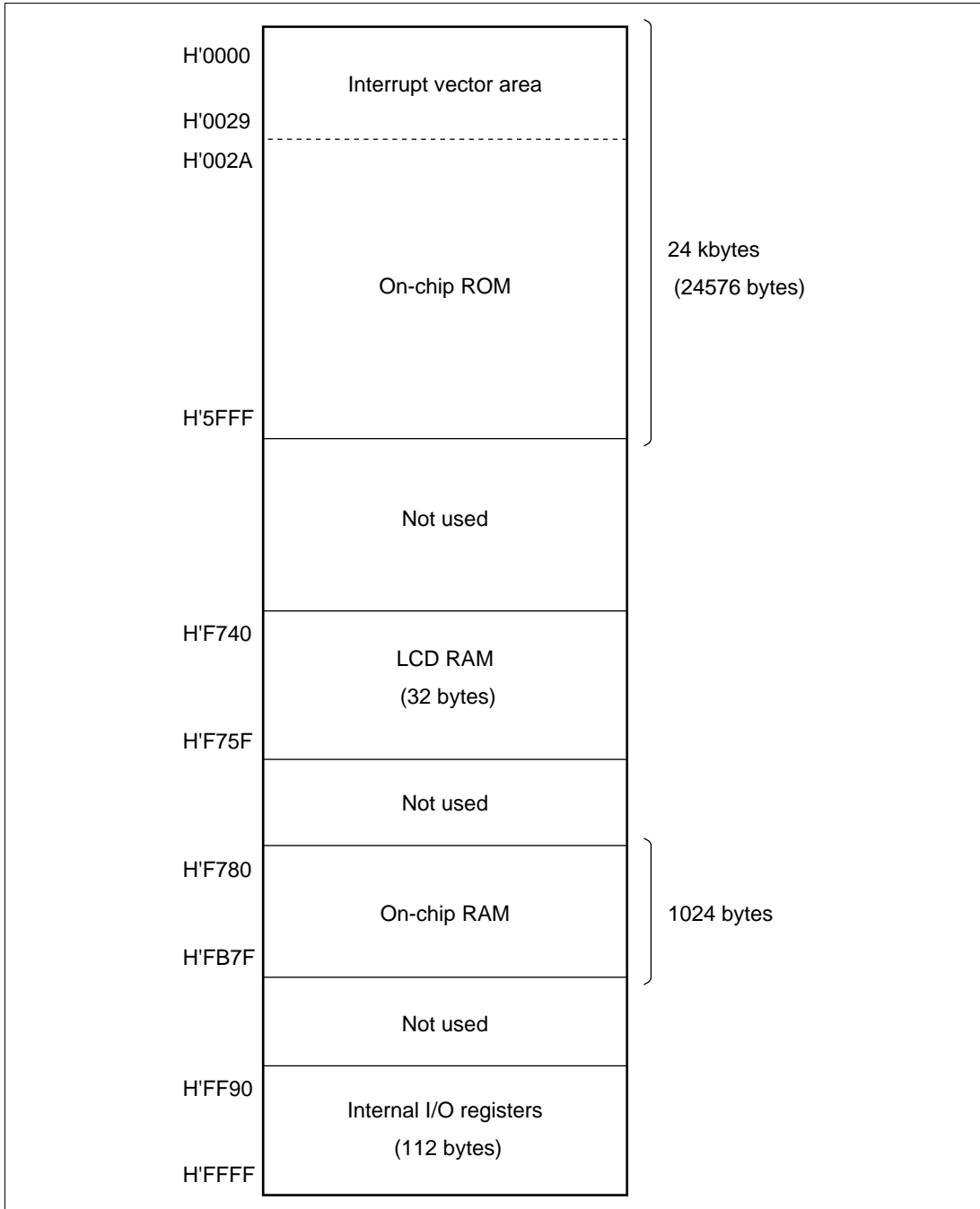

Figure 2.16 (2) H8/3863 and H8/3823 Memory Map

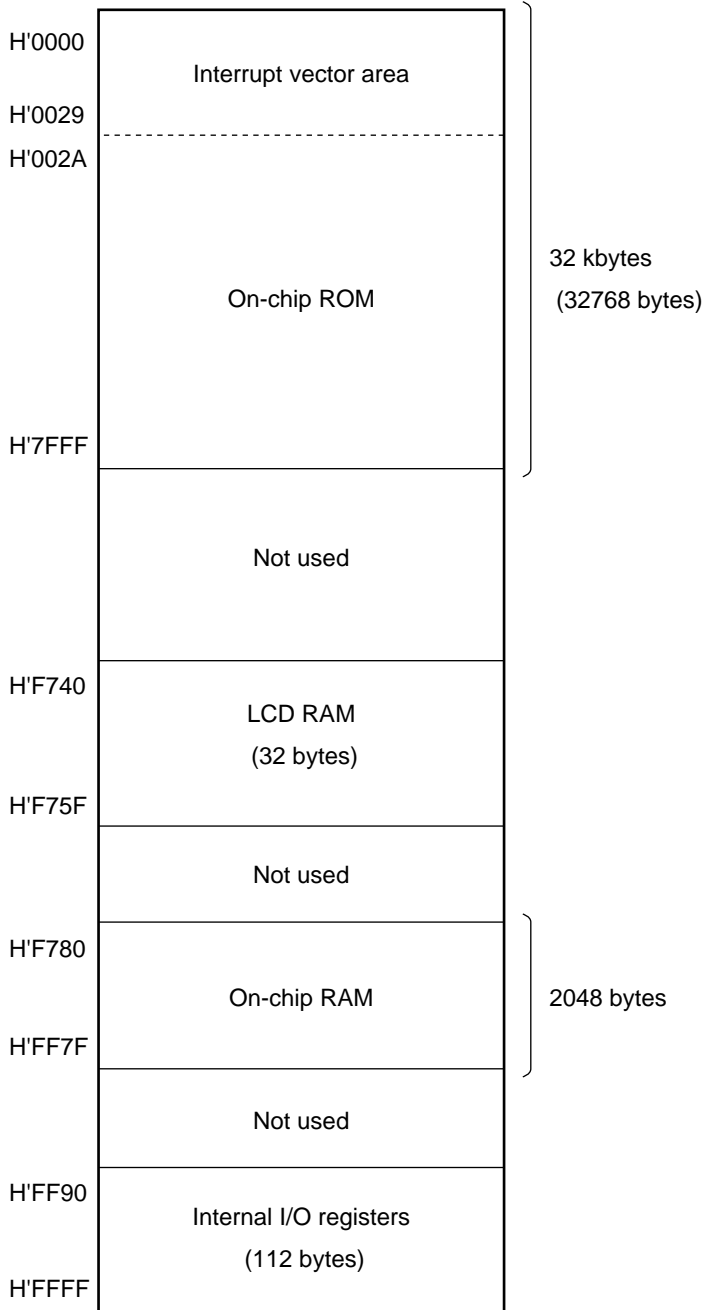

Figure 2.16 (3) H8/3864 and H8/3824 Memory Map

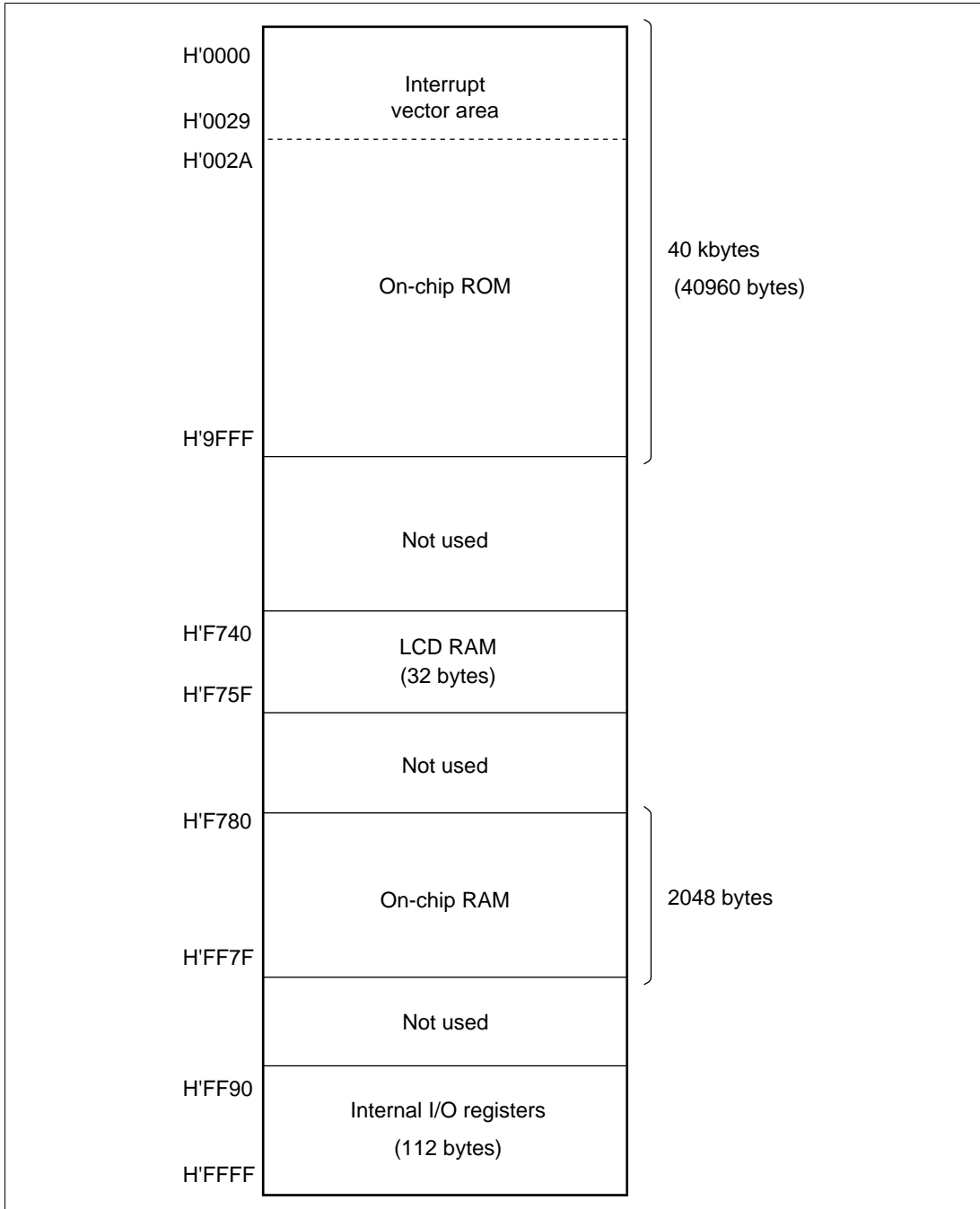

Figure 2.16 (4) H8/3865 and H8/3825 Memory Map

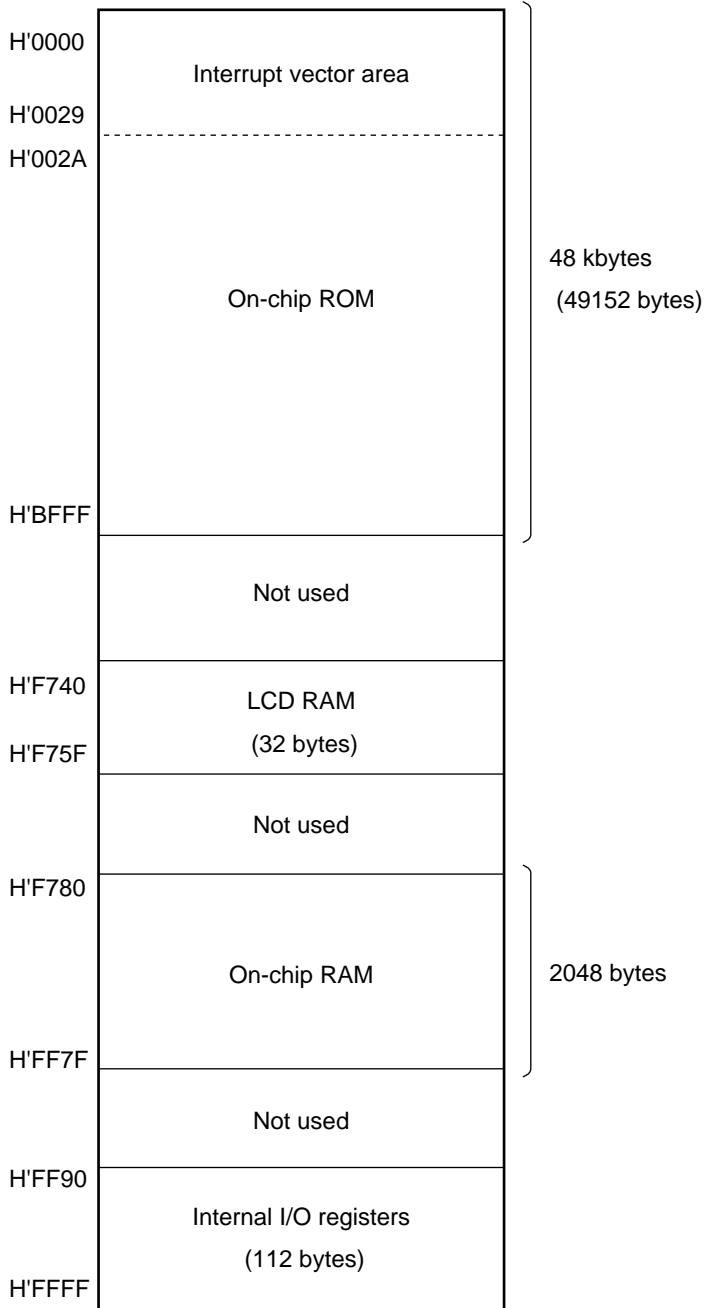

Figure 2.16 (5) H8/3866 and H8/3826 Memory Map

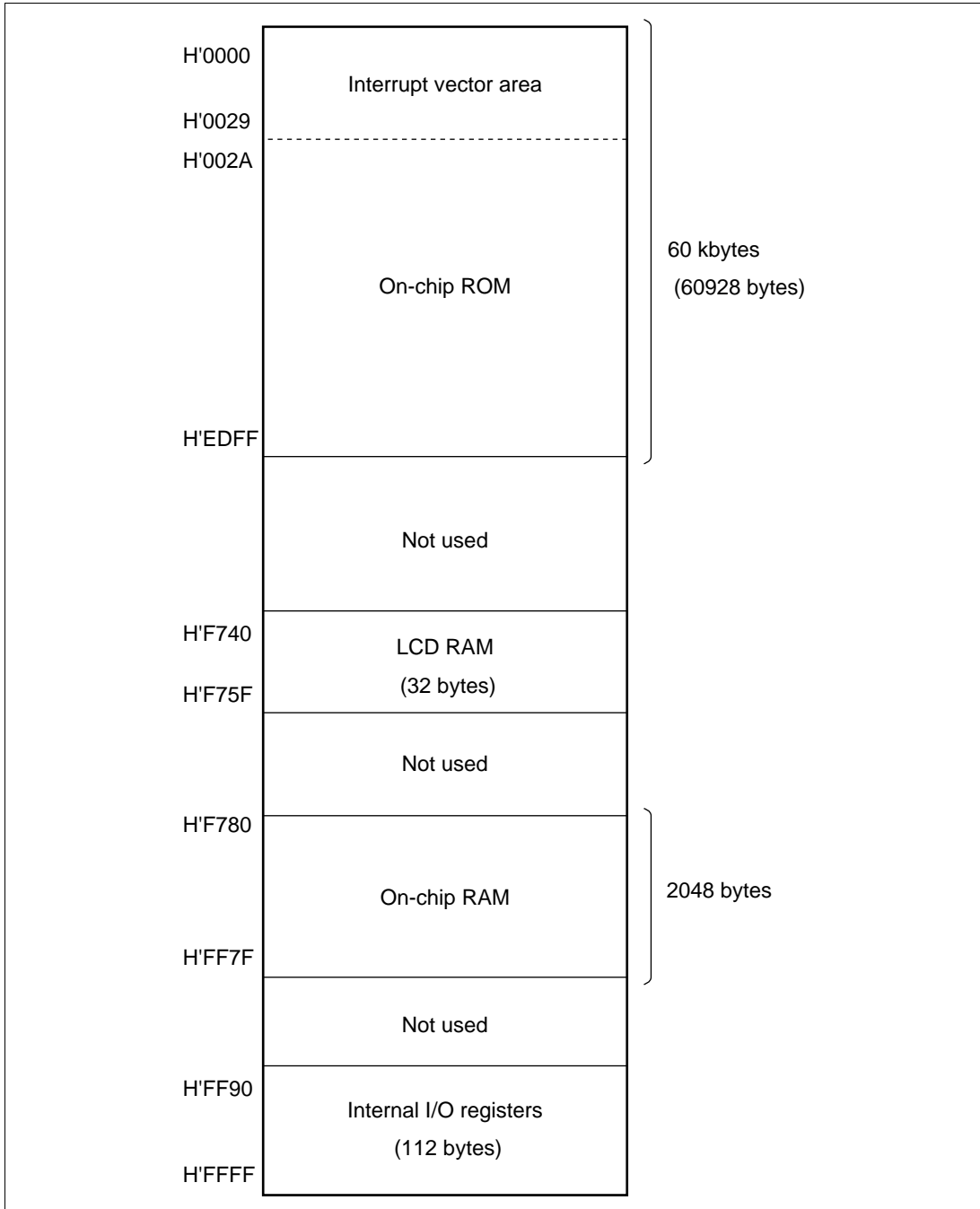

Figure 2.16 (6) H8/3867 and H8/3827 Memory Map

2.9 Application Notes

2.9.1 Notes on Data Access

1. Access to Empty Areas:

The address space of the H8/300L CPU includes empty areas in addition to the RAM, registers, and ROM areas available to the user. If these empty areas are mistakenly accessed by an application program, the following results will occur.

Data transfer from CPU to empty area:

The transferred data will be lost. This action may also cause the CPU to misoperate.

Data transfer from empty area to CPU:

Unpredictable data is transferred.

2. Access to Internal I/O Registers:

Internal data transfer to or from on-chip modules other than the ROM and RAM areas makes use of an 8-bit data width. If word access is attempted to these areas, the following results will occur.

Word access from CPU to I/O register area:

Upper byte: Will be written to I/O register.

Lower byte: Transferred data will be lost.

Word access from I/O register to CPU:

Upper byte: Will be written to upper part of CPU register.

Lower byte: Unpredictable data will be written to lower part of CPU register.

Byte size instructions should therefore be used when transferring data to or from I/O registers other than the on-chip ROM and RAM areas. Figure 2.17 shows the data size and number of states in which on-chip peripheral modules can be accessed.

| | | Access | | States | | | | |
|----------|---------------------------------------|------------------|------|--------|-----------------------|---|---|---|
| | | Word | Byte | | | | | |
| H'0000 | Interrupt vector area (42 bytes) | ○ | ○ | 2 | | | | |
| H'0029 | | | | | | | | |
| H'002A | On-chip ROM | ○ | ○ | 2 | | | | |
| H'7FFF | | | | | | | | |
| | | | | | Not used | — | — | — |
| H'740 | | | | | | | | |
| H'740 | | | | | LCD RAM (32 bytes) | ○ | ○ | 2 |
| H'75F | | | | | Not used | — | — | — |
| H'780 | | | | | | | | |
| H'780 | | | | | On-chip RAM | ○ | ○ | 2 |
| H'FF7F*2 | | | | | | | | |
| | | | | | Not used | — | — | — |
| H'FF90 | | | | | | | | |
| H'FF90 | Internal I/O registers (112 bytes) | × | ○ | 2 | | | | |
| | | H'FF98 to H'FF9F | × | ○ | 3 | | | |
| | | × | ○ | 2 | | | | |
| | | H'FFA8 to H'FFAF | × | ○ | 3 | | | |
| H'FFFF | | × | ○ | 2 | | | | |

Notes: The example of the H8/3864 and H8/3824 is shown here.

1. This address is H'3FFF in the H8/3862 and H8/3822 (16-kbyte on-chip ROM), H'5FFF in the H8/3863 and H8/3823 (24-kbyte on-chip ROM), H'9FFF in the H8/3865 and H8/3825 (40-kbyte on-chip ROM), H'BFFF in the H8/3866 and H8/3826 (48-kbyte on-chip ROM), and H'EDFF in the H8/3867 and H8/3827 (60-kbyte on-chip ROM).
2. This address is H'FB7F in the H8/3862, H8/3822, H8/3863, and H8/3823 (1024 bytes of on-chip RAM).

Figure 2.17 Data Size and Number of States for Access to and from On-Chip Peripheral Modules

2.9.2 Notes on Bit Manipulation

The BSET, BCLR, BNOT, BST, and BIST instructions read one byte of data, modify the data, then write the data byte again. Special care is required when using these instructions in cases where two registers are assigned to the same address, in the case of registers that include write-only bits, and when the instruction accesses an I/O port.

| Order of Operation | Operation | |
|--------------------|-----------|---|
| 1 | Read | Read byte data at the designated address |
| 2 | Modify | Modify a designated bit in the read data |
| 3 | Write | Write the altered byte data to the designated address |

1. Bit manipulation in two registers assigned to the same address

Example 1: timer load register and timer counter

Figure 2.18 shows an example in which two timer registers share the same address. When a bit manipulation instruction accesses the timer load register and timer counter of a reloadable timer, since these two registers share the same address, the following operations take place.

| Order of Operation | Operation | |
|--------------------|-----------|---|
| 1 | Read | Timer counter data is read (one byte) |
| 2 | Modify | The CPU modifies (sets or resets) the bit designated in the instruction |
| 3 | Write | The altered byte data is written to the timer load register |

The timer counter is counting, so the value read is not necessarily the same as the value in the timer load register. As a result, bits other than the intended bit in the timer load register may be modified to the timer counter value.

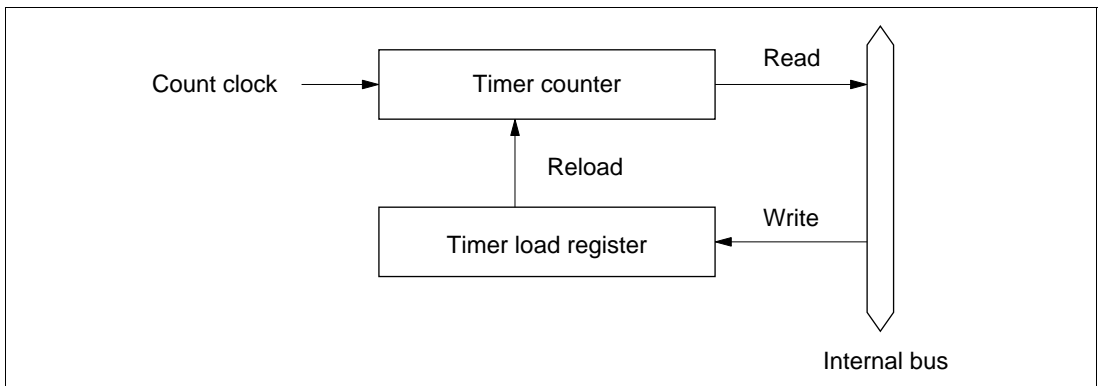

Figure 2.18 Timer Configuration Example

Example 2: BSET instruction executed designating port 3

P3₇ and P3₆ are designated as input pins, with a low-level signal input at P3₇ and a high-level signal at P3₆. The remaining pins, P3₅ to P3₀, are output pins and output low-level signals. In this example, the BSET instruction is used to change pin P3₀ to high-level output.

[A: Prior to executing BSET]

| | P3 ₇ | P3 ₆ | P3 ₅ | P3 ₄ | P3 ₃ | P3 ₂ | P3 ₁ | P3 ₀ |
|--------------|-----------------|-----------------|-----------------|-----------------|-----------------|-----------------|-----------------|-----------------|
| Input/output | Input | Input | Output | Output | Output | Output | Output | Output |
| Pin state | Low level | High level | Low level | Low level | Low level | Low level | Low level | Low level |
| PCR3 | 0 | 0 | 1 | 1 | 1 | 1 | 1 | 1 |
| PDR3 | 1 | 0 | 0 | 0 | 0 | 0 | 0 | 0 |

[B: BSET instruction executed]

```
BSET #0 , @PDR3
```

The BSET instruction is executed designating port 3.

[C: After executing BSET]

| | P3 ₇ | P3 ₆ | P3 ₅ | P3 ₄ | P3 ₃ | P3 ₂ | P3 ₁ | P3 ₀ |
|--------------|-----------------|-----------------|-----------------|-----------------|-----------------|-----------------|-----------------|-----------------|
| Input/output | Input | Input | Output | Output | Output | Output | Output | Output |
| Pin state | Low level | High level | Low level | Low level | Low level | Low level | Low level | High level |
| PCR3 | 0 | 0 | 1 | 1 | 1 | 1 | 1 | 1 |
| PDR3 | 0 | 1 | 0 | 0 | 0 | 0 | 0 | 1 |

[D: Explanation of how BSET operates]

When the BSET instruction is executed, first the CPU reads port 3.

Since P3₇ and P3₆ are input pins, the CPU reads the pin states (low-level and high-level input). P3₅ to P3₀ are output pins, so the CPU reads the value in PDR3. In this example PDR3 has a value of H'80, but the value read by the CPU is H'40.

Next, the CPU sets bit 0 of the read data to 1, changing the PDR3 data to H'41. Finally, the CPU writes this value (H'41) to PDR3, completing execution of BSET.

As a result of this operation, bit 0 in PDR3 becomes 1, and P3₀ outputs a high-level signal. However, bits 7 and 6 of PDR3 end up with different values.

To avoid this problem, store a copy of the PDR3 data in a work area in memory. Perform the bit manipulation on the data in the work area, then write this data to PDR3.

[A: Prior to executing BSET]

```
MOV. B  #80,  R0L
MOV. B  R0L,  @RAM0
MOV. B  R0L,  @PDR3
```

The PDR3 value (H'80) is written to a work area in memory (RAM0) as well as to PDR3

| | P3₇ | P3₆ | P3₅ | P3₄ | P3₃ | P3₂ | P3₁ | P3₀ |
|--------------|-----------------------|-----------------------|-----------------------|-----------------------|-----------------------|-----------------------|-----------------------|-----------------------|
| Input/output | Input | Input | Output | Output | Output | Output | Output | Output |
| Pin state | Low level | High level | Low level | Low level | Low level | Low level | Low level | Low level |
| PCR3 | 0 | 0 | 1 | 1 | 1 | 1 | 1 | 1 |
| PDR3 | 1 | 0 | 0 | 0 | 0 | 0 | 0 | 0 |
| RAM0 | 1 | 0 | 0 | 0 | 0 | 0 | 0 | 0 |

[B: BSET instruction executed]

```
BSET  #0 ,  @RAM0
```

The BSET instruction is executed designating the PDR3 work area (RAM0).

[C: After executing BSET]

```
MOV. B  @RAM0, R0L
MOV. B  R0L,  @PDR3
```

The work area (RAM0) value is written to PDR3.

| | P3₇ | P3₆ | P3₅ | P3₄ | P3₃ | P3₂ | P3₁ | P3₀ |
|--------------|-----------------------|-----------------------|-----------------------|-----------------------|-----------------------|-----------------------|-----------------------|-----------------------|
| Input/output | Input | Input | Output | Output | Output | Output | Output | Output |
| Pin state | Low level | High level | Low level | Low level | Low level | Low level | Low level | High level |
| PCR3 | 0 | 0 | 1 | 1 | 1 | 1 | 1 | 1 |
| PDR3 | 1 | 0 | 0 | 0 | 0 | 0 | 0 | 1 |
| RAM0 | 1 | 0 | 0 | 0 | 0 | 0 | 0 | 1 |

2. Bit manipulation in a register containing a write-only bit

Example 3: BCLR instruction executed designating port 3 control register PCR3

As in the examples above, P3₇ and P3₆ are input pins, with a low-level signal input at P3₇ and a high-level signal at P3₆. The remaining pins, P3₅ to P3₀, are output pins that output low-level signals. In this example, the BCLR instruction is used to change pin P3₀ to an input port. It is assumed that a high-level signal will be input to this input pin.

[A: Prior to executing BCLR]

| | P3 ₇ | P3 ₆ | P3 ₅ | P3 ₄ | P3 ₃ | P3 ₂ | P3 ₁ | P3 ₀ |
|--------------|-----------------|-----------------|-----------------|-----------------|-----------------|-----------------|-----------------|-----------------|
| Input/output | Input | Input | Output | Output | Output | Output | Output | Output |
| Pin state | Low level | High level | Low level | Low level | Low level | Low level | Low level | Low level |
| PCR3 | 0 | 0 | 1 | 1 | 1 | 1 | 1 | 1 |
| PDR3 | 1 | 0 | 0 | 0 | 0 | 0 | 0 | 0 |

[B: BCLR instruction executed]

```
BCLR #0 , @PCR3
```

The BCLR instruction is executed designating PCR3.

[C: After executing BCLR]

| | P3 ₇ | P3 ₆ | P3 ₅ | P3 ₄ | P3 ₃ | P3 ₂ | P3 ₁ | P3 ₀ |
|--------------|-----------------|-----------------|-----------------|-----------------|-----------------|-----------------|-----------------|-----------------|
| Input/output | Output | Output | Output | Output | Output | Output | Output | Input |
| Pin state | Low level | High level | Low level | Low level | Low level | Low level | Low level | High level |
| PCR3 | 1 | 1 | 1 | 1 | 1 | 1 | 1 | 0 |
| PDR3 | 1 | 0 | 0 | 0 | 0 | 0 | 0 | 0 |

[D: Explanation of how BCLR operates]

When the BCLR instruction is executed, first the CPU reads PCR3. Since PCR3 is a write-only register, the CPU reads a value of H'FF, even though the PCR3 value is actually H'3F.

Next, the CPU clears bit 0 in the read data to 0, changing the data to H'FE. Finally, this value (H'FE) is written to PCR3 and BCLR instruction execution ends.

As a result of this operation, bit 0 in PCR3 becomes 0, making P3₀ an input port. However, bits 7 and 6 in PCR3 change to 1, so that P3₇ and P3₆ change from input pins to output pins.

To avoid this problem, store a copy of the PCR3 data in a work area in memory. Perform the bit manipulation on the data in the work area, then write this data to PCR3.

[A: Prior to executing BCLR]

```
MOV. B  #3F,  R0L
MOV. B  R0L,  @RAM0
MOV. B  R0L,  @PCR3
```

The PCR3 value (H'3F) is written to a work area in memory (RAM0) as well as to PCR3.

| | P3₇ | P3₆ | P3₅ | P3₄ | P3₃ | P3₂ | P3₁ | P3₀ |
|--------------|-----------------------|-----------------------|-----------------------|-----------------------|-----------------------|-----------------------|-----------------------|-----------------------|
| Input/output | Input | Input | Output | Output | Output | Output | Output | Output |
| Pin state | Low level | High level | Low level | Low level | Low level | Low level | Low level | Low level |
| PCR3 | 0 | 0 | 1 | 1 | 1 | 1 | 1 | 1 |
| PDR3 | 1 | 0 | 0 | 0 | 0 | 0 | 0 | 0 |
| RAM0 | 0 | 0 | 1 | 1 | 1 | 1 | 1 | 1 |

[B: BCLR instruction executed]

```
BCLR  #0 ,  @RAM0
```

The BCLR instruction is executed designating the PCR3 work area (RAM0).

[C: After executing BCLR]

```
MOV. B  @RAM0, R0L
MOV. B  R0L,  @PCR3
```

The work area (RAM0) value is written to PCR3.

| | P3₇ | P3₆ | P3₅ | P3₄ | P3₃ | P3₂ | P3₁ | P3₀ |
|--------------|-----------------------|-----------------------|-----------------------|-----------------------|-----------------------|-----------------------|-----------------------|-----------------------|
| Input/output | Input | Input | Output | Output | Output | Output | Output | Output |
| Pin state | Low level | High level | Low level | Low level | Low level | Low level | Low level | High level |
| PCR3 | 0 | 0 | 1 | 1 | 1 | 1 | 1 | 0 |
| PDR3 | 1 | 0 | 0 | 0 | 0 | 0 | 0 | 0 |
| RAM0 | 0 | 0 | 1 | 1 | 1 | 1 | 1 | 0 |

Table 2.12 lists the pairs of registers that share identical addresses. Table 2.13 lists the registers that contain write-only bits.

Table 2.12 Registers with Shared Addresses

| Register Name | Abbreviation | Address |
|---|---------------------|----------------|
| Timer counter and timer load register C | TCC/TLC | H'FFB5 |
| Port data register 1* | PDR1 | H'FFD4 |
| Port data register 3* | PDR3 | H'FFD6 |
| Port data register 4* | PDR4 | H'FFD7 |
| Port data register 5* | PDR5 | H'FFD8 |
| Port data register 6* | PDR6 | H'FFD9 |
| Port data register 7* | PDR7 | H'FFDA |
| Port data register 8* | PDR8 | H'FFDB |
| Port data register A* | PDRA | H'FFDD |

Note: * Port data registers have the same addresses as input pins.

Table 2.13 Registers with Write-Only Bits

| Register Name | Abbreviation | Address |
|--------------------------|---------------------|----------------|
| Port control register 1 | PCR1 | H'FFE4 |
| Port control register 3 | PCR3 | H'FFE6 |
| Port control register 4 | PCR4 | H'FFE7 |
| Port control register 5 | PCR5 | H'FFE8 |
| Port control register 6 | PCR6 | H'FFE9 |
| Port control register 7 | PCR7 | H'FFEA |
| Port control register 8 | PCR8 | H'FFEB |
| Port control register A | PCRA | H'FFED |
| Timer control register F | TCRF | H'FFB6 |
| PWM control register | PWCR | H'FFD0 |
| PWM data register U | PWDRU | H'FFD1 |
| PWM data register L | PWDRL | H'FFD2 |

2.9.3 Notes on Use of the EEPMOV Instruction

- The EEPMOV instruction is a block data transfer instruction. It moves the number of bytes specified by R4L from the address specified by R5 to the address specified by R6.

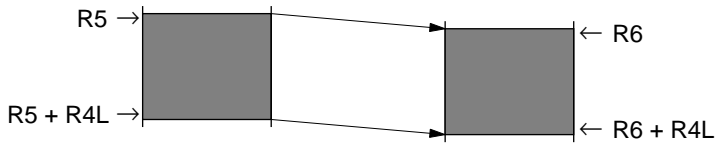

- When setting R4L and R6, make sure that the final destination address ($R6 + R4L$) does not exceed H'FFFF. The value in R6 must not change from H'FFFF to H'0000 during execution of the instruction.

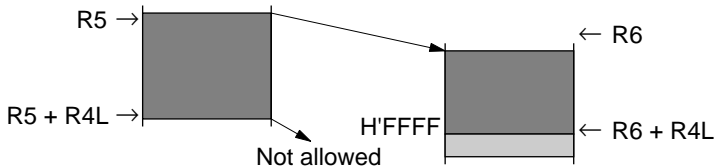

Section 3 Exception Handling

3.1 Overview

Exception handling is performed in the H8/3864 Series when a reset or interrupt occurs. Table 3.1 shows the priorities of these two types of exception handling.

Table 3.1 Exception Handling Types and Priorities

| Priority | Exception Source | Time of Start of Exception Handling |
|----------|------------------|---|
| High | Reset | Exception handling starts as soon as the reset state is cleared |
| ↑ | Interrupt | When an interrupt is requested, exception handling starts after execution of the present instruction or the exception handling in progress is completed |
| Low | | |

3.2 Reset

3.2.1 Overview

A reset is the highest-priority exception. The internal state of the CPU and the registers of the on-chip peripheral modules are initialized.

3.2.2 Reset Sequence

As soon as the $\overline{\text{RES}}$ pin goes low, all processing is stopped and the chip enters the reset state.

To make sure the chip is reset properly, observe the following precautions.

- At power on: Hold the $\overline{\text{RES}}$ pin low until the clock pulse generator output stabilizes.
- Resetting during operation: Hold the $\overline{\text{RES}}$ pin low for at least 10 system clock cycles.

Reset exception handling takes place as follows.

- The CPU internal state and the registers of on-chip peripheral modules are initialized, with the I bit of the condition code register (CCR) set to 1.
- The PC is loaded from the reset exception handling vector address (H'0000 to H'0001), after which the program starts executing from the address indicated in PC.

When system power is turned on or off, the $\overline{\text{RES}}$ pin should be held low.

Figure 3.1 shows the reset sequence starting from $\overline{\text{RES}}$ input.

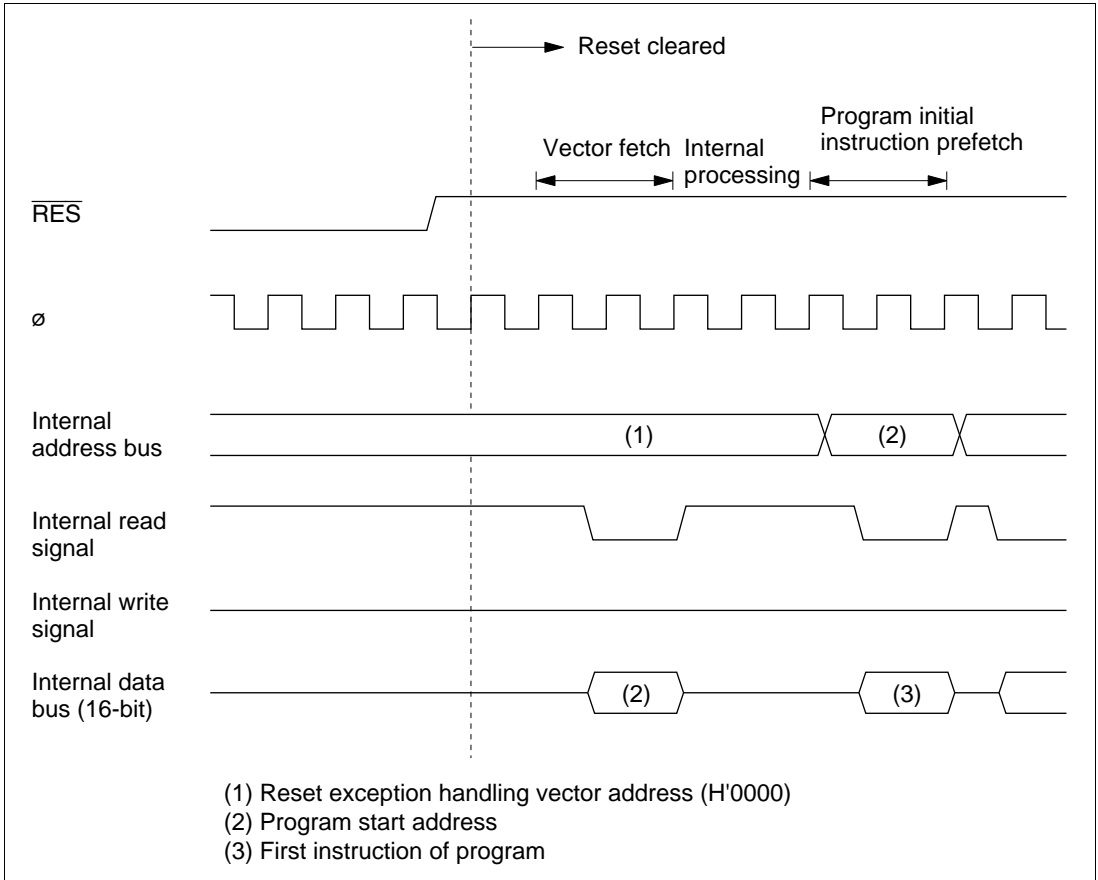

Figure 3.1 Reset Sequence

3.2.3 Interrupt Immediately after Reset

After a reset, if an interrupt were to be accepted before the stack pointer (SP: R7) was initialized, PC and CCR would not be pushed onto the stack correctly, resulting in program runaway. To prevent this, immediately after reset exception handling all interrupts are masked. For this reason, the initial program instruction is always executed immediately after a reset. This instruction should initialize the stack pointer (e.g. MOV.W #xx: 16, SP).

3.3 Interrupts

3.3.1 Overview

The interrupt sources include 13 external interrupts (IRQ₄ to IRQ₀, WKP₇ to WKP₀) and 23 internal interrupts from on-chip peripheral modules. Table 3.2 shows the interrupt sources, their priorities, and their vector addresses. When more than one interrupt is requested, the interrupt with the highest priority is processed.

The interrupts have the following features:

- Internal and external interrupts can be masked by the I bit in CCR. When the I bit is set to 1, interrupt request flags can be set but the interrupts are not accepted.
- IRQ₄ to IRQ₀ and WKP₇ to WKP₀ can be set to either rising edge sensing or falling edge sensing.

Table 3.2 Interrupt Sources and Their Priorities

| Interrupt Source | Interrupt | Vector Number | Vector Address | Priority |
|------------------------------|--|---------------|------------------|----------|
| \overline{RES} | Reset | 0 | H'0000 to H'0001 | |
| $\overline{IRQ_0}$ | IRQ ₀ | 4 | H'0008 to H'0009 | |
| $\overline{IRQ_1}$ | IRQ ₁ | 5 | H'000A to H'000B | |
| $\overline{IRQ_2}$ | IRQ ₂ | 6 | H'000C to H'000D | |
| $\overline{IRQ_3}$ | IRQ ₃ | 7 | H'000E to H'000F | |
| $\overline{IRQ_4}$ | IRQ ₄ | 8 | H'0010 to H'0011 | |
| $\overline{WKP_0}$ | WKP ₀ | 9 | H'0012 to H'0013 | |
| $\overline{WKP_1}$ | WKP ₁ | | | |
| $\overline{WKP_2}$ | WKP ₂ | | | |
| $\overline{WKP_3}$ | WKP ₃ | | | |
| $\overline{WKP_4}$ | WKP ₄ | | | |
| $\overline{WKP_5}$ | WKP ₅ | | | |
| $\overline{WKP_6}$ | WKP ₆ | | | |
| $\overline{WKP_7}$ | WKP ₇ | | | |
| Timer A | Timer A overflow | 11 | H'0016 to H'0017 | |
| Asynchronous counter | Asynchronous counter overflow | 12 | H'0018 to H'0019 | |
| Timer C | Timer C overflow or underflow | 13 | H'001A to H'001B | |
| Timer FL | Timer FL compare match Timer FL overflow | 14 | H'001C to H'001D | |
| Timer FH | Timer FH compare match Timer FH overflow | 15 | H'001E to H'001F | |
| Timer G | Timer G input capture Timer G overflow | 16 | H'0020 to H'0021 | |
| SCI3-1 | SCI3-1 transmit end SCI3-1 transmit data empty SCI3-1 receive data full SCI3-1 overrun error SCI3-1 framing error SCI3-1 parity error | 17 | H'0022 to H'0023 | |
| SCI3-2 | SCI3-2 transmit end SCI3-2 transmit data empty SCI3-2 receive data full SCI3-2 overrun error SCI3-2 framing error SCI3-2 parity error | 18 | H'0024 to H'0025 | |
| A/D | A/D conversion end | 19 | H'0026 to H'0027 | |
| (SLEEP instruction executed) | Direct transfer | 20 | H'0028 to H'0029 | Low |

Note: Vector addresses H'0002 to H'0007 and H'0014 to H'0015 are reserved and cannot be used.

3.3.2 Interrupt Control Registers

Table 3.3 lists the registers that control interrupts.

Table 3.3 Interrupt Control Registers

| Name | Abbreviation | R/W | Initial Value | Address |
|-----------------------------------|--------------|------|---------------|---------|
| IRQ edge select register | IEGR | R/W | H'E0 | H'FFF2 |
| Interrupt enable register 1 | IENR1 | R/W | H'00 | H'FFF3 |
| Interrupt enable register 2 | IENR2 | R/W | H'00 | H'FFF4 |
| Interrupt request register 1 | IRR1 | R/W* | H'20 | H'FFF6 |
| Interrupt request register 2 | IRR2 | R/W* | H'00 | H'FFF7 |
| Wakeup interrupt request register | IWPR | R/W* | H'00 | H'FFF9 |
| Wakeup edge select register | WEGR | R/W | H'00 | H'FF90 |

Note: * Write is enabled only for writing of 0 to clear a flag.

1. IRQ edge select register (IEGR)

| Bit | 7 | 6 | 5 | 4 | 3 | 2 | 1 | 0 |
|---------------|---|---|---|------|------|------|------|------|
| | — | — | — | IEG4 | IEG3 | IEG2 | IEG1 | IEG0 |
| Initial value | 1 | 1 | 1 | 0 | 0 | 0 | 0 | 0 |
| Read/Write | — | — | — | R/W | R/W | R/W | R/W | R/W |

IEGR is an 8-bit read/write register used to designate whether pins $\overline{\text{IRQ}}_4$ to $\overline{\text{IRQ}}_0$ are set to rising edge sensing or falling edge sensing.

Bits 7 to 5: Reserved bits

Bits 7 to 5 are reserved: they are always read as 1 and cannot be modified.

Bit 4: IRQ_4 edge select (IEG4)

Bit 4 selects the input sensing of the $\overline{\text{IRQ}}_4$ pin and $\overline{\text{ADTRG}}$ pin.

Bit 4

| IEG4 | Description |
|------|---|
| 0 | Falling edge of $\overline{\text{IRQ}}_4$ and $\overline{\text{ADTRG}}$ pin input is detected (initial value) |
| 1 | Rising edge of $\overline{\text{IRQ}}_4$ and $\overline{\text{ADTRG}}$ pin input is detected |

Bit 3: IRQ₃ edge select (IEG3)

Bit 3 selects the input sensing of the $\overline{\text{IRQ}}_3$ pin and TMIF pin.

Bit 3**IEG3****Description**

| 0 | Falling edge of $\overline{\text{IRQ}}_3$ and TMIF pin input is detected | (initial value) |
|---|--|-----------------|
| 1 | Rising edge of $\overline{\text{IRQ}}_3$ and TMIF pin input is detected | |

Bit 2: IRQ₂ edge select (IEG2)

Bit 2 selects the input sensing of pin $\overline{\text{IRQ}}_2$.

Bit 2**IEG2****Description**

| 0 | Falling edge of $\overline{\text{IRQ}}_2$ pin input is detected | (initial value) |
|---|---|-----------------|
| 1 | Rising edge of $\overline{\text{IRQ}}_2$ pin input is detected | |

Bit 1: IRQ₁ edge select (IEG1)

Bit 3 selects the input sensing of the $\overline{\text{IRQ}}_1$ pin and TMIC pin.

Bit 1**IEG1****Description**

| 0 | Falling edge of $\overline{\text{IRQ}}_1$ and TMIC pin input is detected | (initial value) |
|---|--|-----------------|
| 1 | Rising edge of $\overline{\text{IRQ}}_1$ and TMIC pin input is detected | |

Bit 0: IRQ₀ edge select (IEG0)

Bit 0 selects the input sensing of pin $\overline{\text{IRQ}}_0$.

Bit 0**IEG0****Description**

| 0 | Falling edge of $\overline{\text{IRQ}}_0$ pin input is detected | (initial value) |
|---|---|-----------------|
| 1 | Rising edge of $\overline{\text{IRQ}}_0$ pin input is detected | |

2. Interrupt enable register 1 (IENR1)

| | | | | | | | | |
|---------------|-------|-----|-------|------|------|------|------|------|
| Bit | 7 | 6 | 5 | 4 | 3 | 2 | 1 | 0 |
| | IENTA | — | IENWP | IEN4 | IEN3 | IEN2 | IEN1 | IEN0 |
| Initial value | 0 | 0 | 0 | 0 | 0 | 0 | 0 | 0 |
| Read/Write | R/W | R/W | R/W | R/W | R/W | R/W | R/W | R/W |

IENR1 is an 8-bit read/write register that enables or disables interrupt requests.

Bit 7: Timer A interrupt enable (IENTA)

Bit 7 enables or disables timer A overflow interrupt requests.

Bit 7

| IENTA | Description |
|-------|---|
| 0 | Disables timer A interrupt requests (initial value) |
| 1 | Enables timer A interrupt requests |

Bit 6: Reserved bit

Bit 6 is a readable/writable reserved bit. It is initialized to 0 by a reset.

Bit 5: Wakeup interrupt enable (IENWP)

Bit 5 enables or disables WKP₇ to WKP₀ interrupt requests.

Bit 5

| IENWP | Description |
|-------|--|
| 0 | Disables \overline{WKP}_7 to \overline{WKP}_0 interrupt requests (initial value) |
| 1 | Enables \overline{WKP}_7 to \overline{WKP}_0 interrupt requests |

Bits 4 to 0: IRQ₄ to IRQ₀ interrupt enable (IEN4 to IEN0)

Bits 4 to 0 enable or disable IRQ₄ to IRQ₀ interrupt requests.

Bit n

| IENn | Description |
|------|--|
| 0 | Disables interrupt requests from pin \overline{IRQn} (initial value) |
| 1 | Enables interrupt requests from pin \overline{IRQn} |

(n = 4 to 0)

3. Interrupt enable register 2 (IENR2)

| | | | | | | | | |
|---------------|-------|-------|-----|-------|--------|--------|-------|-------|
| Bit | 7 | 6 | 5 | 4 | 3 | 2 | 1 | 0 |
| | IENDT | IENAD | — | IENTG | IENTFH | IENTFL | IENTC | IENEC |
| Initial value | 0 | 0 | 0 | 0 | 0 | 0 | 0 | 0 |
| Read/Write | R/W | R/W | R/W | R/W | R/W | R/W | R/W | R/W |

IENR2 is an 8-bit read/write register that enables or disables interrupt requests.

Bit 7: Direct transfer interrupt enable (IENDT)

Bit 7 enables or disables direct transfer interrupt requests.

Bit 7

| IENDT | Description |
|-------|---|
| 0 | Disables direct transfer interrupt requests (initial value) |
| 1 | Enables direct transfer interrupt requests |

Bit 6: A/D converter interrupt enable (IENAD)

Bit 6 enables or disables A/D converter interrupt requests.

Bit 6

| IENAD | Description |
|-------|---|
| 0 | Disables A/D converter interrupt requests (initial value) |
| 1 | Enables A/D converter interrupt requests |

Bit 5: Reserved bit

Bit 5 is a readable/writable reserved bit. It is initialized to 0 by a reset.

Bit 4: Timer G interrupt enable (IENTG)

Bit 4 enables or disables timer G input capture or overflow interrupt requests.

Bit 4

| IENTG | Description |
|-------|---|
| 0 | Disables timer G interrupt requests (initial value) |
| 1 | Enables timer G interrupt requests |

Bit 3: Timer FH interrupt enable (IENTFH)

Bit 3 enables or disables timer FH compare match and overflow interrupt requests.

Bit 3

| IENTFH | Description | |
|---------------|--------------------------------------|-----------------|
| 0 | Disables timer FH interrupt requests | (initial value) |
| 1 | Enables timer FH interrupt requests | |

Bit 2: Timer FL interrupt enable (IENTFL)

Bit 2 enables or disables timer FL compare match and overflow interrupt requests.

Bit 2

| IENTFL | Description | |
|---------------|--------------------------------------|-----------------|
| 0 | Disables timer FL interrupt requests | (initial value) |
| 1 | Enables timer FL interrupt requests | |

Bit 1: Timer C interrupt enable (IENTC)

Bit 1 enables or disables timer C overflow and underflow interrupt requests.

Bit 1

| IENTC | Description | |
|--------------|-------------------------------------|-----------------|
| 0 | Disables timer C interrupt requests | (initial value) |
| 1 | Enables timer C interrupt requests | |

Bit 0: Asynchronous event counter interrupt enable (IENEC)

Bit 0 enables or disables asynchronous event counter interrupt requests.

Bit 0

| IENEC | Description | |
|--------------|--|-----------------|
| 0 | Disables asynchronous event counter interrupt requests | (initial value) |
| 1 | Enables asynchronous event counter interrupt requests | |

For details of SCI3-1 and SCI3-2 interrupt control, see 6. Serial control register 3 (SCR3) in section 10.4.2.

4. Interrupt request register 1 (IRR1)

| | | | | | | | | |
|---------------|-------|------|---|-------|-------|-------|-------|-------|
| Bit | 7 | 6 | 5 | 4 | 3 | 2 | 1 | 0 |
| | IRRTA | — | — | IRRI4 | IRRI3 | IRRI2 | IRRI1 | IRRI0 |
| Initial value | 0 | 0 | 1 | 0 | 0 | 0 | 0 | 0 |
| Read/Write | R/W* | R/W* | — | R/W* | R/W* | R/W* | R/W* | R/W* |

Note: * Only a write of 0 for flag clearing is possible

IRR1 is an 8-bit read/write register, in which a corresponding flag is set to 1 when a timer A or IRQ₄ to IRQ₀ interrupt is requested. The flags are not cleared automatically when an interrupt is accepted. It is necessary to write 0 to clear each flag.

Bit 7: Timer A interrupt request flag (IRRTA)

Bit 7

| IRRTA | Description |
|-------|---|
| 0 | Clearing conditions: When IRRTA = 1, it is cleared by writing 0 (initial value) |
| 1 | Setting conditions: When the timer A counter value overflows from H'FF to H'00 |

Bit 6: Reserved bit

Bit 6 is a readable/writable reserved bit. It is initialized to 0 by a reset.

Bit 5: Reserved bit

Bit 5 is reserved; it is always read as 1 and cannot be modified.

Bits 4 to 0: IRQ₄ to IRQ₀ interrupt request flags (IRRI4 to IRRI0)

Bit n

| IRRI _n | Description |
|-------------------|---|
| 0 | Clearing conditions: When IRRI _n = 1, it is cleared by writing 0 (initial value) |
| 1 | Setting conditions: When pin $\overline{\text{IRQ}}_n$ is designated for interrupt input and the designated signal edge is input |

(n = 4 to 0)

5. Interrupt request register 2 (IRR2)

| Bit | 7 | 6 | 5 | 4 | 3 | 2 | 1 | 0 |
|---------------|-------|-------|-----|-------|--------|--------|-------|-------|
| | IRRDT | IRRAD | — | IRRTG | IRRTFH | IRRTFL | IRRTC | IRREC |
| Initial value | 0 | 0 | 0 | 0 | 0 | 0 | 0 | 0 |
| Read/Write | R/W* | R/W* | R/W | R/W* | R/W* | R/W* | R/W* | R/W* |

Note: * Only a write of 0 for flag clearing is possible

IRR2 is an 8-bit read/write register, in which a corresponding flag is set to 1 when a direct transfer, A/D converter, Timer G, Timer FH, Timer FC, or Timer C interrupt is requested. The flags are not cleared automatically when an interrupt is accepted. It is necessary to write 0 to clear each flag.

Bit 7: Direct transfer interrupt request flag (IRRDT)

Bit 7

| IRRDT | Description |
|-------|---|
| 0 | Clearing conditions: When IRRDT = 1, it is cleared by writing 0 (initial value) |
| 1 | Setting conditions: When a direct transfer is made by executing a SLEEP instruction while DTON = 1 in SYSCR2 |

Bit 6: A/D converter interrupt request flag (IRRAD)

Bit 6

| IRRAD | Description |
|-------|--|
| 0 | Clearing conditions: When IRRAD = 1, it is cleared by writing 0 (initial value) |
| 1 | Setting conditions: When A/D conversion is completed and ADSF is cleared to 0 in ADSR |

Bit 5: Reserved bit

Bit 5 is a readable/writable reserved bit. It is initialized to 0 by a reset.

Bit 4: Timer G interrupt request flag (IRRTG)

Bit 4

IRRTG

Description

| | | |
|---|--|-----------------|
| 0 | Clearing conditions: When IRRTG = 1, it is cleared by writing 0 | (initial value) |
| 1 | Setting conditions: When the TMIG pin is designated for TMIG input and the designated signal edge is input, or when TCG overflows while OVIE is set to 1 in TMG | |

Bit 3: Timer FH interrupt request flag (IRRTFH)

Bit 3

IRRTFH

Description

| | | |
|---|---|-----------------|
| 0 | Clearing conditions: When IRRTFH = 1, it is cleared by writing 0 | (initial value) |
| 1 | Setting conditions: When TCFH and OCRFH match in 8-bit timer mode, or when TCF (TCFL, TCFH) and OCRF (OCRFL, OCRFH) match in 16-bit timer mode | |

Bit 2: Timer FL interrupt request flag (IRRTFL)

Bit 2

IRRTFL

Description

| | | |
|---|--|-----------------|
| 0 | Clearing conditions: When IRRTFL= 1, it is cleared by writing 0 | (initial value) |
| 1 | Setting conditions: When TCFL and OCRFL match in 8-bit timer mode | |

Bit 1: Timer C interrupt request flag (IRRTC)

Bit 1

IRRTC

Description

| | | |
|---|---|-----------------|
| 0 | Clearing conditions: When IRRTC= 1, it is cleared by writing 0 | (initial value) |
| 1 | Setting conditions: When the timer C counter value overflows (from H'FF to H'00) or underflows (from H'00 to H'FF) | |

Bit 0: Asynchronous event counter interrupt request flag (IRREC)**Bit 0**

| IRREC | Description |
|-------|---|
| 0 | Clearing conditions: When IRREC = 1, it is cleared by writing 0 (initial value) |
| 1 | Setting conditions: When ECH overflows in 16-bit counter mode, or ECH or ECL overflows in 8-bit counter mode |

6. Wakeup Interrupt Request Register (IWPR)

| Bit | 7 | 6 | 5 | 4 | 3 | 2 | 1 | 0 |
|---------------|-------|-------|-------|-------|-------|-------|-------|-------|
| | IWPF7 | IWPF6 | IWPF5 | IWPF4 | IWPF3 | IWPF2 | IWPF1 | IWPF0 |
| Initial value | 0 | 0 | 0 | 0 | 0 | 0 | 0 | 0 |
| Read/Write | R/W* | R/W* | R/W* | R/W* | R/W* | R/W* | R/W* | R/W* |

Note: * Only a write of 0 for flag clearing is possible

IWPR is an 8-bit read/write register containing wakeup interrupt request flags. When one of pins \overline{WKP}_7 to \overline{WKP}_0 is designated for wakeup input and a rising or falling edge is input at that pin, the corresponding flag in IWPR is set to 1. A flag is not cleared automatically when the corresponding interrupt is accepted. Flags must be cleared by writing 0.

Bits 7 to 0: Wakeup interrupt request flags (IWPF7 to IWPF0)**Bit n**

| IWPFn | Description |
|-------|---|
| 0 | Clearing conditions: When IWPFn = 1, it is cleared by writing 0 (initial value) |
| 1 | Setting conditions: When pin \overline{WKP}_n is designated for wakeup input and a rising or falling edge is input at that pin |

(n = 7 to 0)

7. Wakeup Edge Select Register (WEGR)

| Bit | 7 | 6 | 5 | 4 | 3 | 2 | 1 | 0 |
|---------------|--------|--------|--------|--------|--------|--------|--------|--------|
| | WKEGS7 | WKEGS6 | WKEGS5 | WKEGS4 | WKEGS3 | WKEGS2 | WKEGS1 | WKEGS0 |
| Initial value | 0 | 0 | 0 | 0 | 0 | 0 | 0 | 0 |
| Read/Write | R/W | R/W | R/W | R/W | R/W | R/W | R/W | R/W |

WEGR is an 8-bit read/write register that specifies rising or falling edge sensing for pins $\overline{\text{WKP}}_n$.

WEGR is initialized to H'00 by a reset.

Bit n: $\overline{\text{WKP}}_n$ edge select (WKEGSn)

Bit n selects $\overline{\text{WKP}}_n$ pin input sensing.

Bit n

| WKEGSn | Description |
|--------|---|
| 0 | $\overline{\text{WKP}}_n$ pin falling edge detected (initial value) |
| 1 | $\overline{\text{WKP}}_n$ pin rising edge detected |

(n = 7 to 0)

3.3.3 External Interrupts

There are 13 external interrupts: IRQ₄ to IRQ₀ and WKP₇ to WKP₀.

1. Interrupts WKP₇ to WKP₀

Interrupts WKP₇ to WKP₀ are requested by either rising or falling edge input to pins $\overline{\text{WKP}}_7$ to $\overline{\text{WKP}}_0$. When these pins are designated as pins $\overline{\text{WKP}}_7$ to $\overline{\text{WKP}}_0$ in port mode register 5 and a rising or falling edge is input, the corresponding bit in IWPR is set to 1, requesting an interrupt. Recognition of wakeup interrupt requests can be disabled by clearing the IENWP bit to 0 in IENR1. These interrupts can all be masked by setting the I bit to 1 in CCR.

When WKP₇ to WKP₀ interrupt exception handling is initiated, the I bit is set to 1 in CCR. Vector number 9 is assigned to interrupts WKP₇ to WKP₀. All eight interrupt sources have the same vector number, so the interrupt-handling routine must discriminate the interrupt source.

2. Interrupts IRQ₄ to IRQ₀

Interrupts IRQ₄ to IRQ₀ are requested by input signals to pins $\overline{\text{IRQ}}_4$ to $\overline{\text{IRQ}}_0$. These interrupts are detected by either rising edge sensing or falling edge sensing, depending on the settings of bits IEG4 to IEG0 in IEGR.

When these pins are designated as pins $\overline{\text{IRQ}}_4$ to $\overline{\text{IRQ}}_0$ in port mode register 3 and 1 and the designated edge is input, the corresponding bit in IRR1 is set to 1, requesting an interrupt. Recognition of these interrupt requests can be disabled individually by clearing bits IEN4 to IEN0 to 0 in IENR1. These interrupts can all be masked by setting the I bit to 1 in CCR.

When IRQ₄ to IRQ₀ interrupt exception handling is initiated, the I bit is set to 1 in CCR. Vector numbers 8 to 4 are assigned to interrupts IRQ₄ to IRQ₀. The order of priority is from IRQ₀ (high) to IRQ₄ (low). Table 3.2 gives details.

3.3.4 Internal Interrupts

There are 23 internal interrupts that can be requested by the on-chip peripheral modules. When a peripheral module requests an interrupt, the corresponding bit in IRR1 or IRR2 is set to 1. Recognition of individual interrupt requests can be disabled by clearing the corresponding bit in IENR1 or IENR2. All these interrupts can be masked by setting the I bit to 1 in CCR. When internal interrupt handling is initiated, the I bit is set to 1 in CCR. Vector numbers from 20 to 11 are assigned to these interrupts. Table 3.2 shows the order of priority of interrupts from on-chip peripheral modules.

3.3.5 Interrupt Operations

Interrupts are controlled by an interrupt controller. Figure 3.2 shows a block diagram of the interrupt controller. Figure 3.3 shows the flow up to interrupt acceptance.

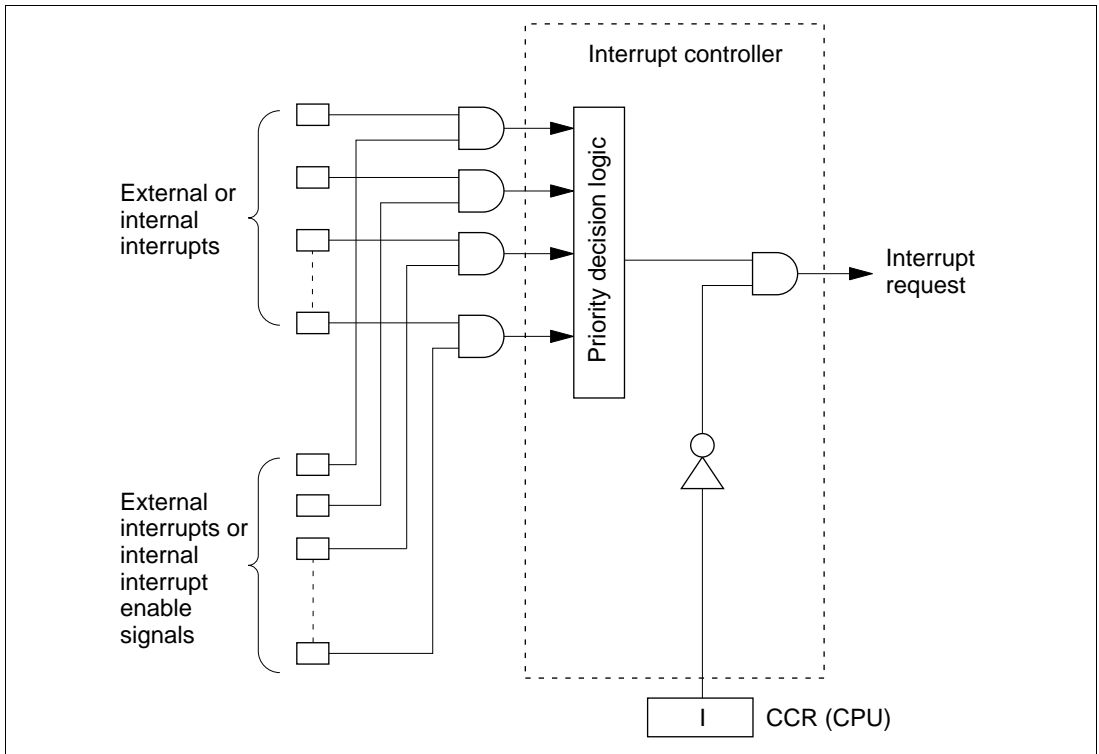

Figure 3.2 Block Diagram of Interrupt Controller

Interrupt operation is described as follows.

- When an interrupt condition is met while the interrupt enable register bit is set to 1, an interrupt request signal is sent to the interrupt controller.
- When the interrupt controller receives an interrupt request, it sets the interrupt request flag.
- From among the interrupts with interrupt request flags set to 1, the interrupt controller selects the interrupt request with the highest priority and holds the others pending. (Refer to table 3.2 for a list of interrupt priorities.)
- The interrupt controller checks the I bit of CCR. If the I bit is 0, the selected interrupt request is accepted; if the I bit is 1, the interrupt request is held pending.

- If the interrupt is accepted, after processing of the current instruction is completed, both PC and CCR are pushed onto the stack. The state of the stack at this time is shown in figure 3.4. The PC value pushed onto the stack is the address of the first instruction to be executed upon return from interrupt handling.
- The I bit of CCR is set to 1, masking further interrupts.
- The vector address corresponding to the accepted interrupt is generated, and the interrupt handling routine located at the address indicated by the contents of the vector address is executed.

Notes:

1. When disabling interrupts by clearing bits in an interrupt enable register, or when clearing bits in an interrupt request register, always do so while interrupts are masked ($I = 1$).
2. If the above clear operations are performed while $I = 0$, and as a result a conflict arises between the clear instruction and an interrupt request, exception processing for the interrupt will be executed after the clear instruction has been executed.

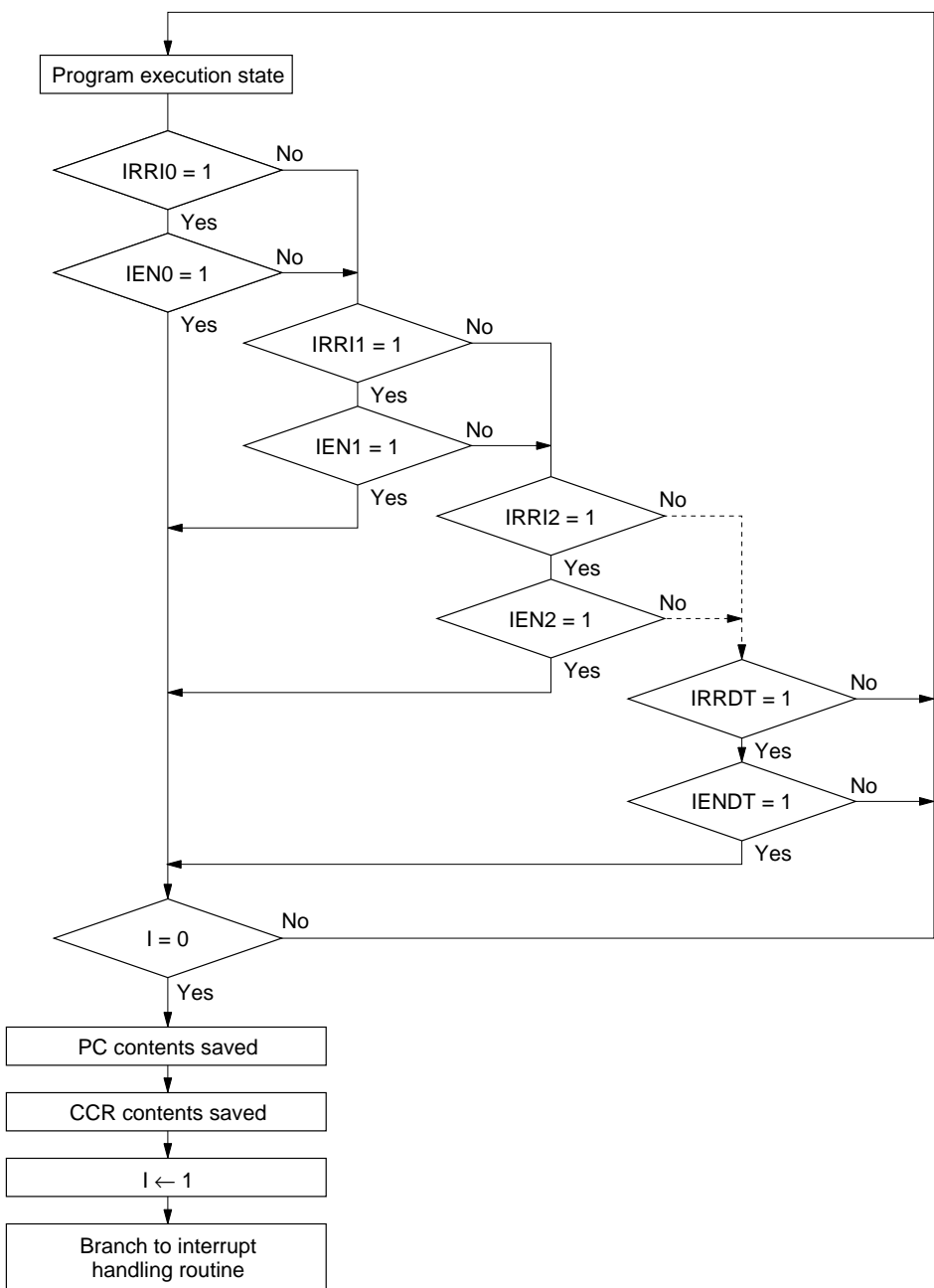

Notation:

PC: Program counter

CCR: Condition code register

I: I bit of CCR

Figure 3.3 Flow up to Interrupt Acceptance

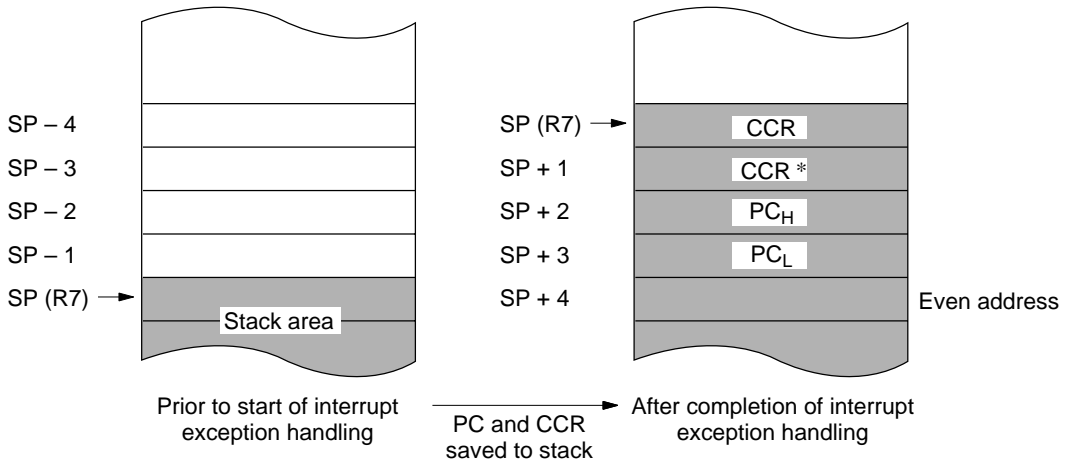

Notation:

PC_H: Upper 8 bits of program counter (PC)

PC_L: Lower 8 bits of program counter (PC)

CCR: Condition code register

SP: Stack pointer

Notes: 1. PC shows the address of the first instruction to be executed upon return from the interrupt handling routine.

2. Register contents must always be saved and restored by word access, starting from an even-numbered address.

* Ignored on return.

Figure 3.4 Stack State after Completion of Interrupt Exception Handling

Figure 3.5 shows a typical interrupt sequence.

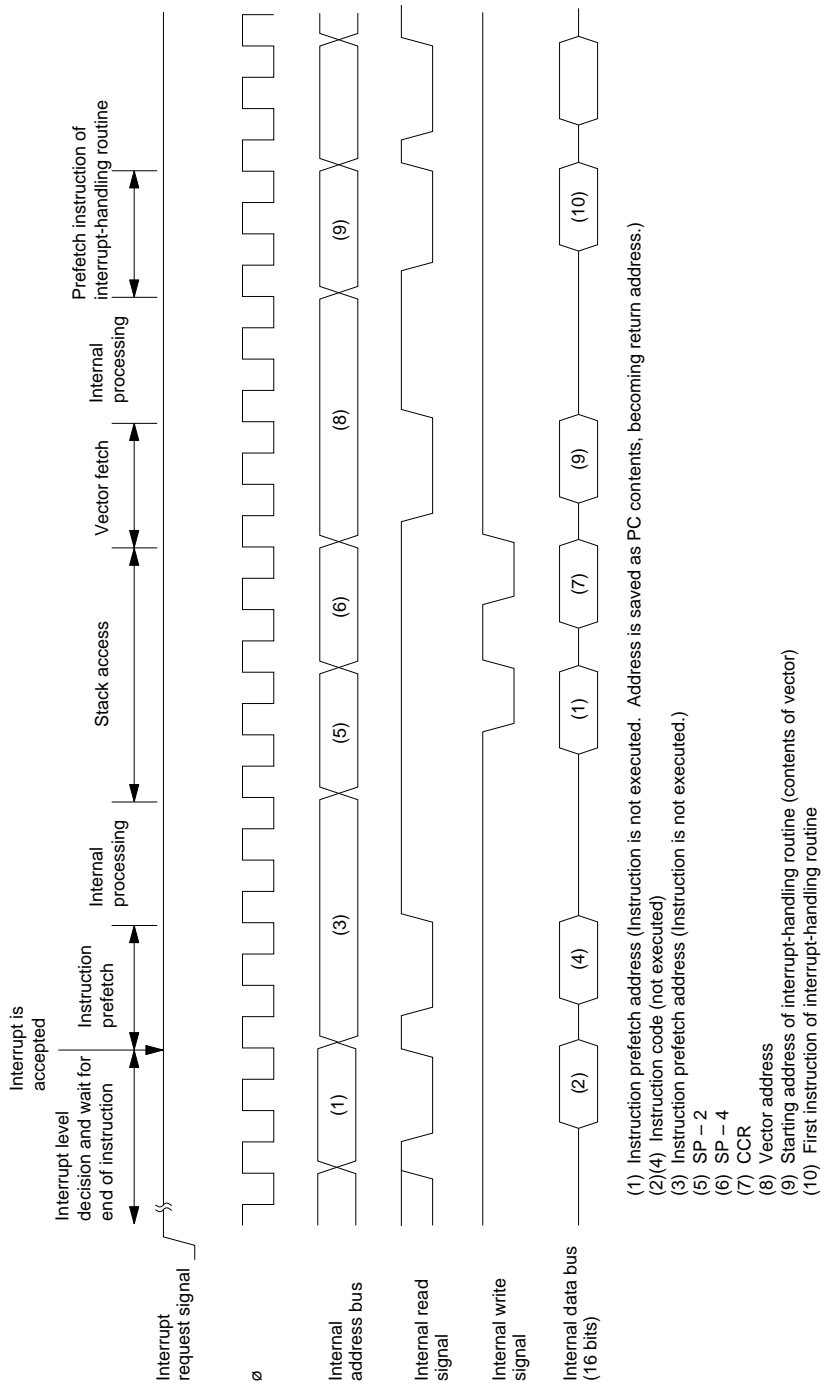

Figure 3.5 Interrupt Sequence

3.3.6 Interrupt Response Time

Table 3.4 shows the number of wait states after an interrupt request flag is set until the first instruction of the interrupt handler is executed.

Table 3.4 Interrupt Wait States

| Item | States | Total |
|---|---------------|--------------|
| Waiting time for completion of executing instruction* | 1 to 13 | 15 to 27 |
| Saving of PC and CCR to stack | 4 | |
| Vector fetch | 2 | |
| Instruction fetch | 4 | |
| Internal processing | 4 | |

Note: * Not including EEPMOV instruction.

3.4 Application Notes

3.4.1 Notes on Stack Area Use

When word data is accessed in the H8/3864 Series, the least significant bit of the address is regarded as 0. Access to the stack always takes place in word size, so the stack pointer (SP: R7) should never indicate an odd address. Use PUSH Rn (MOV.W Rn, @-SP) or POP Rn (MOV.W @SP+, Rn) to save or restore register values.

Setting an odd address in SP may cause a program to crash. An example is shown in figure 3.6.

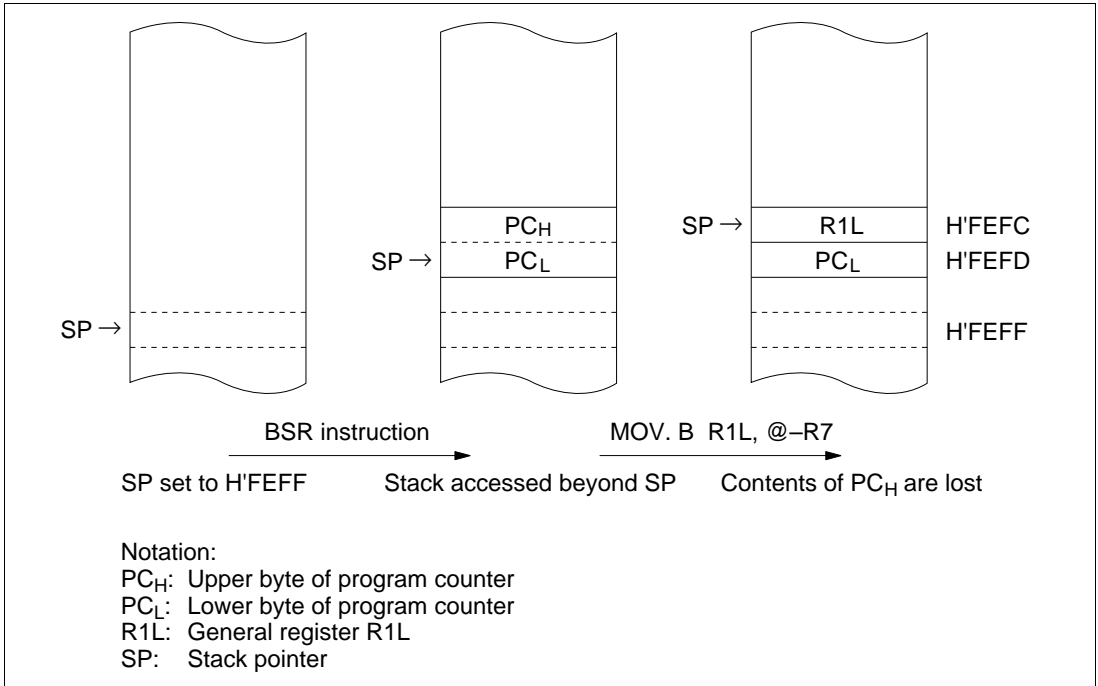

Figure 3.6 Operation when Odd Address is Set in SP

When CCR contents are saved to the stack during interrupt exception handling or restored when RTE is executed, this also takes place in word size. Both the upper and lower bytes of word data are saved to the stack; on return, the even address contents are restored to CCR while the odd address contents are ignored.

3.4.2 Notes on Rewriting Port Mode Registers

When a port mode register is rewritten to switch the functions of external interrupt pins, the following points should be observed.

When an external interrupt pin function is switched by rewriting the port mode register that controls pins $\overline{\text{IRQ}}_4$ to $\overline{\text{IRQ}}_0$, $\overline{\text{WKP}}_7$ to $\overline{\text{WKP}}_0$, the interrupt request flag may be set to 1 at the time the pin function is switched, even if no valid interrupt is input at the pin. Be sure to clear the interrupt request flag to 0 after switching pin functions. Table 3.5 shows the conditions under which interrupt request flags are set to 1 in this way.

Table 3.5 Conditions under which Interrupt Request Flag is Set to 1

| Interrupt Request Flags Set to 1 | | Conditions |
|----------------------------------|-------|--|
| IRR1 | IRRI4 | When PMR1 bit IRQ4 is changed from 0 to 1 while pin $\overline{\text{IRQ}}_4$ is low and IEGR bit IEG4 = 0. When PMR1 bit IRQ4 is changed from 1 to 0 while pin $\overline{\text{IRQ}}_4$ is low and IEGR bit IEG4 = 1. |
| | IRRI3 | When PMR1 bit IRQ3 is changed from 0 to 1 while pin $\overline{\text{IRQ}}_3$ is low and IEGR bit IEG3 = 0. When PMR1 bit IRQ3 is changed from 1 to 0 while pin $\overline{\text{IRQ}}_3$ is low and IEGR bit IEG3 = 1. |
| | IRRI2 | When PMR1 bit IRQ2 is changed from 0 to 1 while pin $\overline{\text{IRQ}}_2$ is low and IEGR bit IEG2 = 0. When PMR1 bit IRQ2 is changed from 1 to 0 while pin $\overline{\text{IRQ}}_2$ is low and IEGR bit IEG2 = 1. |
| | IRRI1 | When PMR1 bit IRQ1 is changed from 0 to 1 while pin $\overline{\text{IRQ}}_1$ is low and IEGR bit IEG1 = 0. When PMR1 bit IRQ1 is changed from 1 to 0 while pin $\overline{\text{IRQ}}_1$ is low and IEGR bit IEG1 = 1. |
| | IRRI0 | When PMR3 bit IRQ0 is changed from 0 to 1 while pin $\overline{\text{IRQ}}_0$ is low and IEGR bit IEG0 = 0. When PMR3 bit IRQ0 is changed from 1 to 0 while pin $\overline{\text{IRQ}}_0$ is low and IEGR bit IEG0 = 1. |
| | IWPR | IWPF7 |
| IWPF6 | | When PMR5 bit WKP6 is changed from 0 to 1 while pin $\overline{\text{WKP}}_6$ is low. |
| IWPF5 | | When PMR5 bit WKP5 is changed from 0 to 1 while pin $\overline{\text{WKP}}_5$ is low. |
| IWPF4 | | When PMR5 bit WKP4 is changed from 0 to 1 while pin $\overline{\text{WKP}}_4$ is low. |
| IWPF3 | | When PMR5 bit WKP3 is changed from 0 to 1 while pin $\overline{\text{WKP}}_3$ is low. |
| IWPF2 | | When PMR5 bit WKP2 is changed from 0 to 1 while pin $\overline{\text{WKP}}_2$ is low. |
| IWPF1 | | When PMR5 bit WKP1 is changed from 0 to 1 while pin $\overline{\text{WKP}}_1$ is low. |
| IWPF0 | | When PMR5 bit WKP0 is changed from 0 to 1 while pin $\overline{\text{WKP}}_0$ is low. |

Figure 3.7 shows the procedure for setting a bit in a port mode register and clearing the interrupt request flag.

When switching a pin function, mask the interrupt before setting the bit in the port mode register. After accessing the port mode register, execute at least one instruction (e.g., NOP), then clear the interrupt request flag from 1 to 0. If the instruction to clear the flag is executed immediately after the port mode register access without executing an intervening instruction, the flag will not be cleared.

An alternative method is to avoid the setting of interrupt request flags when pin functions are switched by keeping the pins at the high level so that the conditions in table 3.5 do not occur.

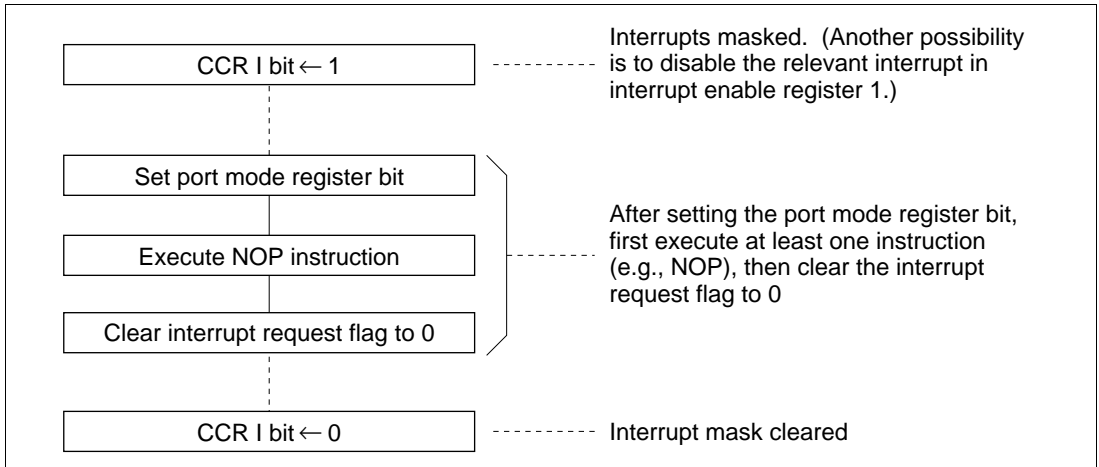

Figure 3.7 Port Mode Register Setting and Interrupt Request Flag Clearing Procedure

Section 4 Clock Pulse Generators

4.1 Overview

Clock oscillator circuitry (CPG: clock pulse generator) is provided on-chip, including both a system clock pulse generator and a subclock pulse generator. The system clock pulse generator consists of a system clock oscillator and system clock dividers. The subclock pulse generator consists of a subclock oscillator circuit and a subclock divider.

4.1.1 Block Diagram

Figure 4.1 shows a block diagram of the clock pulse generators.

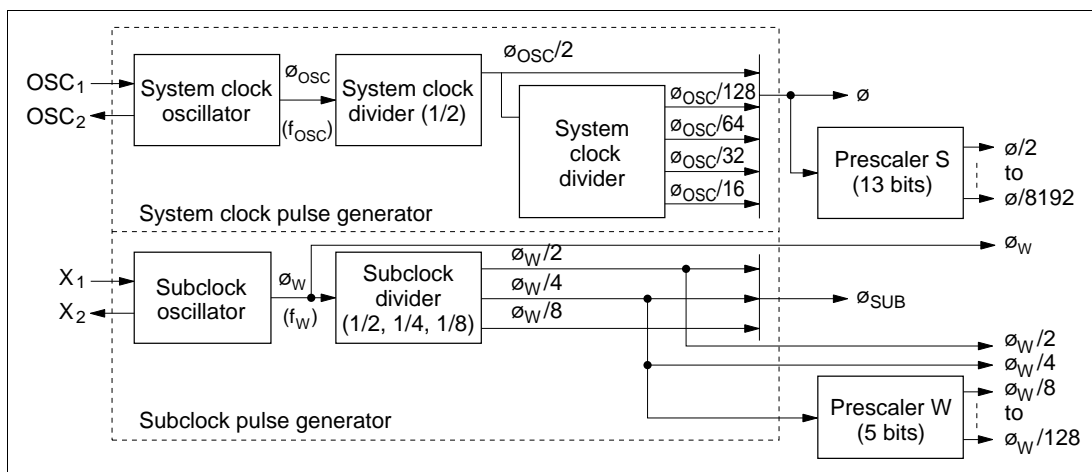

Figure 4.1 Block Diagram of Clock Pulse Generators

4.1.2 System Clock and Subclock

The basic clock signals that drive the CPU and on-chip peripheral modules are ϕ and ϕ_{SUB} . Four of the clock signals have names: ϕ is the system clock, ϕ_{SUB} is the subclock, ϕ_{OSC} is the oscillator clock, and ϕ_W is the watch clock.

The clock signals available for use by peripheral modules are $\phi/2$, $\phi/4$, $\phi/8$, $\phi/16$, $\phi/32$, $\phi/64$, $\phi/128$, $\phi/256$, $\phi/512$, $\phi/1024$, $\phi/2048$, $\phi/4096$, $\phi/8192$, ϕ_W , $\phi_W/2$, $\phi_W/4$, $\phi_W/8$, $\phi_W/16$, $\phi_W/32$, $\phi_W/64$, and $\phi_W/128$. The clock requirements differ from one module to another.

4.2 System Clock Generator

Clock pulses can be supplied to the system clock divider either by connecting a crystal or ceramic oscillator, or by providing external clock input.

1. Connecting a crystal oscillator

Figure 4.2 shows a typical method of connecting a crystal oscillator.

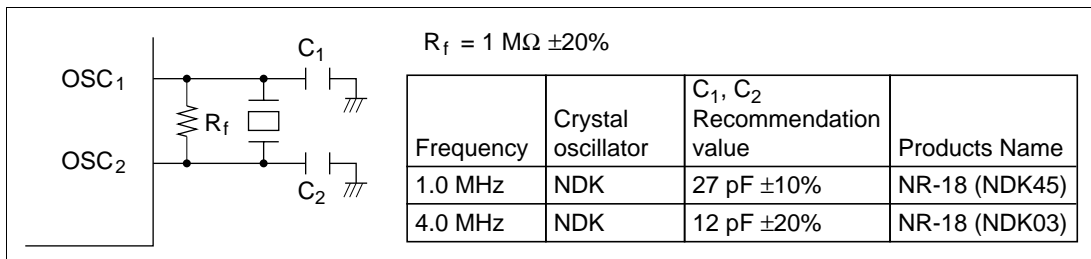

Figure 4.2 Typical Connection to Crystal Oscillator

Figure 4.3 shows the equivalent circuit of a crystal oscillator. An oscillator having the characteristics given in table 4.1 should be used.

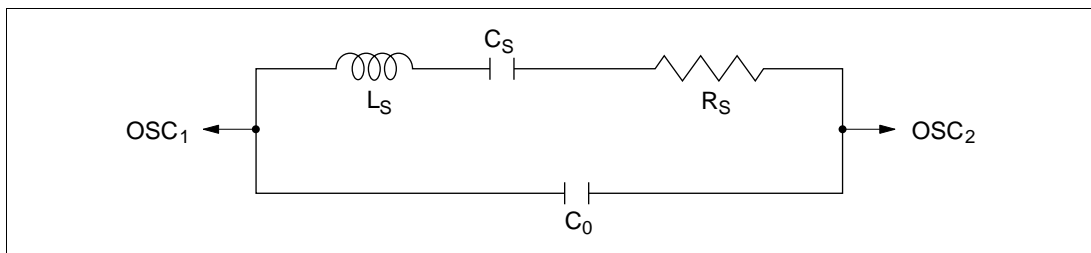

Figure 4.3 Equivalent Circuit of Crystal Oscillator

Table 4.1 Crystal Oscillator Parameters

| | | |
|---------------------|------------|-------|
| Frequency (MHz) | 1 | 4.193 |
| RS max () | 40 | 100 |
| C ₀ (pF) | 3.5 pF max | 16 pF |

2. Connecting a ceramic oscillator

Figure 4.4 shows a typical method of connecting a ceramic oscillator.

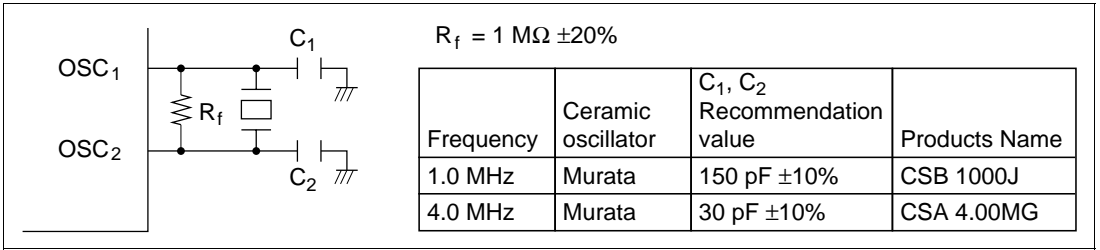

Figure 4.4 Typical Connection to Ceramic Oscillator

3. Notes on board design

When generating clock pulses by connecting a crystal or ceramic oscillator, pay careful attention to the following points.

Avoid running signal lines close to the oscillator circuit, since the oscillator may be adversely affected by induction currents. (See figure 4.5.)

The board should be designed so that the oscillator and load capacitors are located as close as possible to pins OSC_1 and OSC_2 .

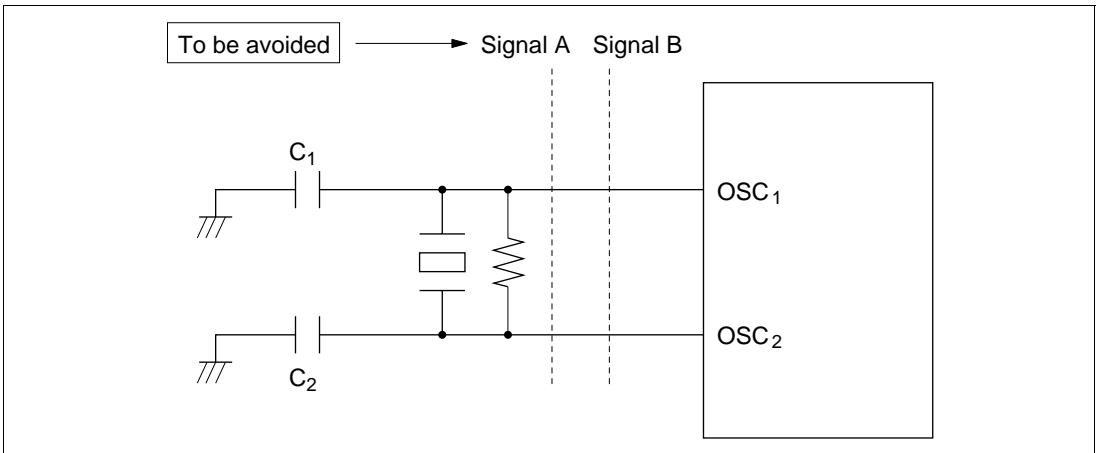

Figure 4.5 Board Design of Oscillator Circuit

4. External clock input method

Connect an external clock signal to pin OSC₁, and leave pin OSC₂ open. Figure 4.6 shows a typical connection.

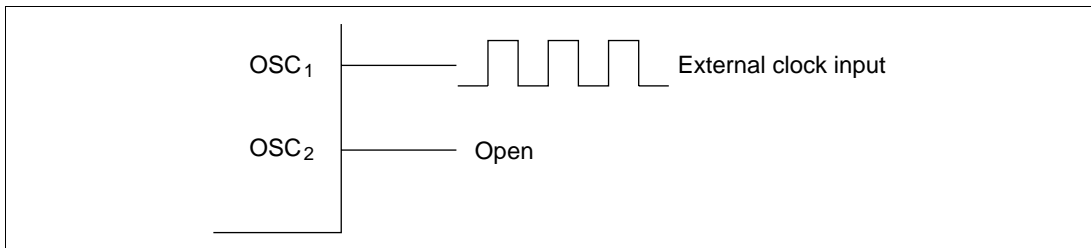

Figure 4.6 External Clock Input (Example)

| Frequency | Oscillator Clock (ϕ_{OSC}) |
|------------------|---|
| Duty cycle | 45% to 55% |

Note: The circuit parameters above are recommended by the crystal or ceramic oscillator manufacturer.

The circuit parameters are affected by the crystal or ceramic oscillator and floating capacitance when designing the board. When using the oscillator, consult with the crystal or ceramic oscillator manufacturer to determine the circuit parameters.

4.3 Subclock Generator

1. Connecting a 32.768-kHz/38.4 kHz crystal oscillator

Clock pulses can be supplied to the subclock divider by connecting a 32.768-kHz/38.4 kHz crystal oscillator, as shown in figure 4.7. Follow the same precautions as noted under 3. notes on board design for the system clock in 4.2.

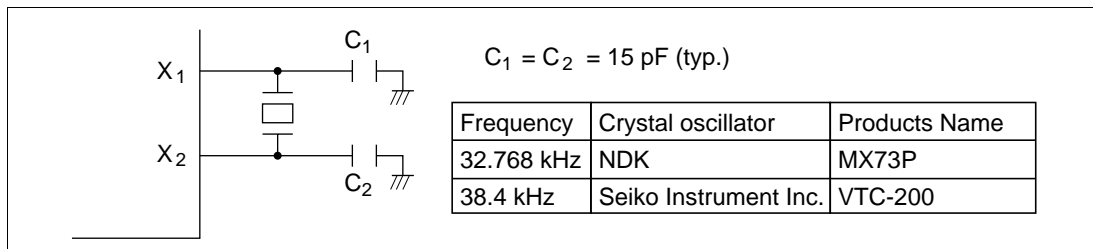

Figure 4.7 Typical Connection to 32.768-kHz/38.4 kHz Crystal Oscillator (Subclock)

Figure 4.8 shows the equivalent circuit of the 32.768-kHz/38.4 kHz crystal oscillator.

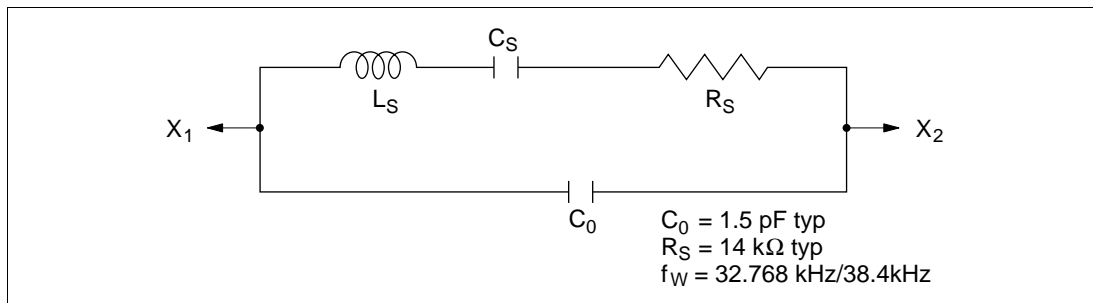

Figure 4.8 Equivalent Circuit of 32.768-kHz/38.4 kHz Crystal Oscillator

2. Pin connection when not using subclock

When the subclock is not used, connect pin X₁ to GND and leave pin X₂ open, as shown in figure 4.9.

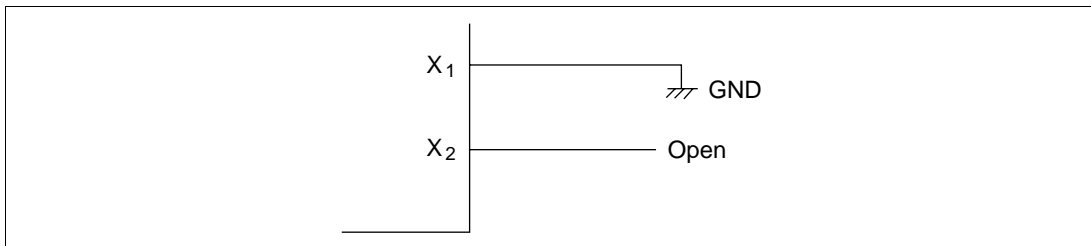

Figure 4.9 Pin Connection when not Using Subclock

3. External clock input

Connect the external clock to the X₁ pin and leave the X₂ pin open, as shown in figure 4.10.

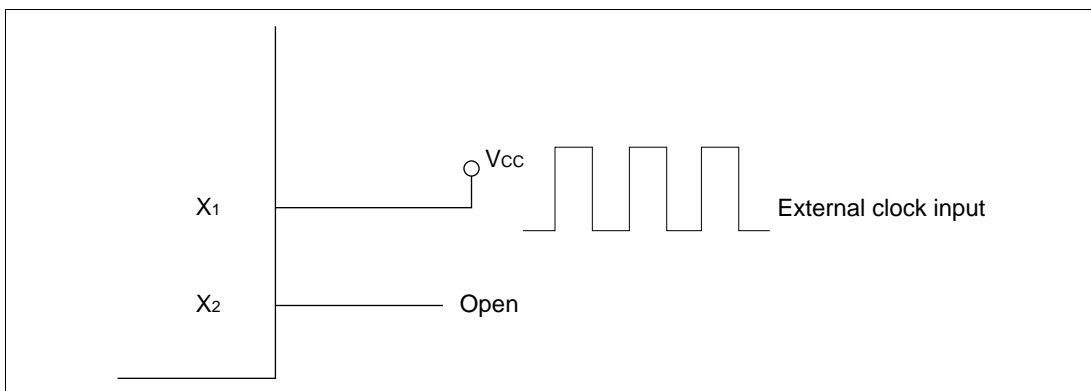

Figure 4.10 Pin Connection when Inputting External Clock

Frequency

Subclock (ϕw)

Duty

45% to 55%

4.4 Prescalers

The H8/3864 Series is equipped with two on-chip prescalers having different input clocks (prescaler S and prescaler W). Prescaler S is a 13-bit counter using the system clock (ϕ) as its input clock. Its prescaled outputs provide internal clock signals for on-chip peripheral modules. Prescaler W is a 5-bit counter using a 32.768-kHz or 38.4 kHz signal divided by 4 ($\phi_W/4$) as its input clock. Its prescaled outputs are used by timer A as a time base for timekeeping.

1. Prescaler S (PSS)

Prescaler S is a 13-bit counter using the system clock (ϕ) as its input clock. It is incremented once per clock period.

Prescaler S is initialized to H'0000 by a reset, and starts counting on exit from the reset state.

In standby mode, watch mode, subactive mode, and subsleep mode, the system clock pulse generator stops. Prescaler S also stops and is initialized to H'0000.

The CPU cannot read or write prescaler S.

The output from prescaler S is shared by timer A, timer C, timer F, timer G, SCI3-1, SC3-2, the A/D converter, the LCD controller, the watchdog timer, and the 14-bit PWM. The divider ratio can be set separately for each on-chip peripheral function.

In active (medium-speed) mode the clock input to prescaler S is $\phi_{osc}/16$, $\phi_{osc}/32$, $\phi_{osc}/64$, or $\phi_{osc}/128$.

2. Prescaler W (PSW)

Prescaler W is a 5-bit counter using a 32.768 kHz/38.4 kHz signal divided by 4 ($\phi_W/4$) as its input clock.

Prescaler W is initialized to H'00 by a reset, and starts counting on exit from the reset state.

Even in standby mode, watch mode, subactive mode, or subsleep mode, prescaler W continues functioning so long as clock signals are supplied to pins X1 and X2.

Prescaler W can be reset by setting 1s in bits TMA3 and TMA2 of timer mode register A (TMA).

Output from prescaler W can be used to drive timer A, in which case timer A functions as a time base for timekeeping.

4.5 Note on Oscillators

Oscillator characteristics are closely related to board design and should be carefully evaluated by the user in mask ROM and ZTAT™ versions, referring to the examples shown in this section. Oscillator circuit constants will differ depending on the oscillator element, stray capacitance in its interconnecting circuit, and other factors. Suitable constants should be determined in consultation with the oscillator element manufacturer. Design the circuit so that the oscillator element never receives voltages exceeding its maximum rating.

Section 5 Power-Down Modes

5.1 Overview

The H8/3864 Series has nine modes of operation after a reset. These include eight power-down modes, in which power dissipation is significantly reduced. Table 5.1 gives a summary of the eight operating modes.

Table 5.1 Operating Modes

| Operating Mode | Description |
|----------------------------|--|
| Active (high-speed) mode | The CPU and all on-chip peripheral functions are operable on the system clock in high-speed operation |
| Active (medium-speed) mode | The CPU and all on-chip peripheral functions are operable on the system clock in low-speed operation |
| Subactive mode | The CPU is operable on the subclock in low-speed operation |
| Sleep (high-speed) mode | The CPU halts. On-chip peripheral functions are operable on the system clock |
| Sleep (medium-speed) mode | The CPU halts. On-chip peripheral functions operate at a frequency of 1/64, 1/32, 1/16, or 1/8 of the system clock frequency |
| Subsleep mode | The CPU halts. The time-base function of timer A, timer C, timer G, timer F, WDT, SCI3-1, SCI3-2, AEC and LCD controller/driver are operable on the subclock |
| Watch mode | The CPU halts. The time-base function of timer A, timer F, timer G, AEC and LCD controller/driver are operable on the subclock |
| Standby mode | The CPU and all on-chip peripheral functions halt |
| Module standby mode | Individual on-chip peripheral functions specified by software enter standby mode and halt |

Of these nine operating modes, all but the active (high-speed) mode are power-down modes. In this section the two active modes (high-speed and medium speed) will be referred to collectively as active mode.

Figure 5.1 shows the transitions among these operation modes. Table 5.2 indicates the internal states in each mode.

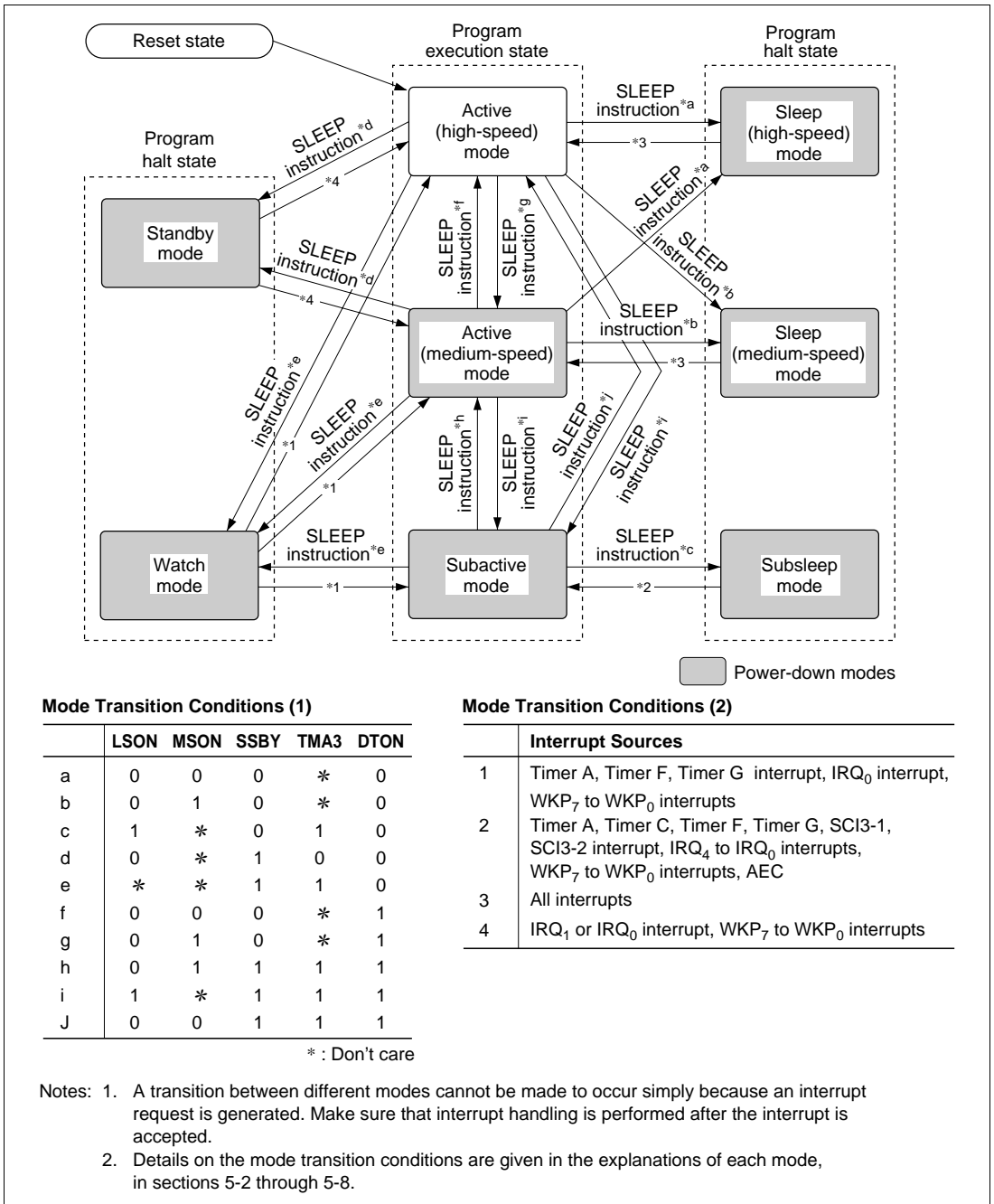

Figure 5.1 Mode Transition Diagram

Table 5.2 Internal State in Each Operating Mode

| Function | Active Mode | | Sleep Mode | | Watch Mode | Subactive Mode | Subsleep Mode | Standby Mode | |
|-------------------------|----------------------|--------------|------------|--------------|------------|---------------------------------|----------------------------------|---------------------------------|-------------------------|
| | High-Speed | Medium-Speed | High-Speed | Medium-Speed | | | | | |
| System clock oscillator | Functions | Functions | Functions | Functions | Halted | Halted | Halted | Halted | |
| Subclock oscillator | Functions | Functions | Functions | Functions | Functions | Functions | Functions | Functions | |
| CPU operations | Instructions | Functions | Functions | Halted | Halted | Halted | Functions | Halted | Halted |
| | RAM | | | Retained | Retained | Retained | | Retained | Retained |
| | Registers | | | | | | | | |
| | I/O ports | | | | | | | | Retained ¹ |
| External interrupts | IRQ ₀ | Functions | Functions | Functions | Functions | Functions | Functions | Functions | Functions |
| | IRQ ₁ | | | | | Retained ⁶ | | | |
| | IRQ ₂ | | | | | | | | Retained ⁶ |
| | IRQ ₃ | | | | | | | | |
| | IRQ ₄ | | | | | | | | |
| | WKP ₀ | Functions | Functions | Functions | Functions | Functions | Functions | Functions | Functions |
| | WKP ₁ | | | | | | | | |
| | WKP ₂ | | | | | | | | |
| | WKP ₃ | | | | | | | | |
| | WKP ₄ | | | | | | | | |
| Peripheral functions | Timer A | Functions | Functions | Functions | Functions | Functions ¹⁵ | Functions ¹⁵ | Functions ¹⁵ | Retained |
| | Asynchronous counter | | | | | Functions ¹⁸ | Functions | Functions | Functions ¹⁸ |
| | Timer C | | | | | Retained | Functions/Retained ² | Functions/Retained ² | Retained |
| | WDT | | | | | | Functions/Retained ¹⁷ | Retained | |
| | Timer G, Timer F | | | | | Functions/Retained ⁹ | Functions/Retained ⁹ | Functions/Retained ⁹ | |
| | SCI3-1 | | | | | Reset | Functions/Retained ³ | Functions/Retained ³ | Reset |
| | SCI3-2 | | | | | | | | |
| | PWM | | | | | Retained | Retained | Retained | Retained |
| | A/D converter | | | | | Retained | Retained | Retained | Retained |
| | LCD | | | | | Functions/Retained ⁴ | Functions/Retained ⁴ | Functions/Retained ⁴ | Retained |

- Notes:
1. Register contents are retained, but output is high-impedance state.
 2. Functions if an external clock or the $\phi_{W/4}$ internal clock is selected; otherwise halted and retained.
 3. Functions if $\phi_{W/2}$ is selected as the internal clock; otherwise halted and retained.
 4. Functions if $\phi_{W/1}$, $\phi_{W/2}$ or $\phi_{W/4}$ is selected as the operating clock; otherwise halted and retained.
 5. Functions if the timekeeping time-base function is selected.
 6. External interrupt requests are ignored. Interrupt request register contents are not altered.
 7. Functions if $\phi_{W/32}$ is selected as the internal clock; otherwise halted and retained.
 8. Incrementing is possible, but interrupt generation is not.
 9. Functions if an external clock or the $\phi_{W/4}$ internal clock is selected; otherwise halted and retained.

5.1.1 System Control Registers

The operation mode is selected using the system control registers described in table 5.3.

Table 5.3 System Control Registers

| Name | Abbreviation | R/W | Initial Value | Address |
|---------------------------|--------------|-----|---------------|---------|
| System control register 1 | SYSCR1 | R/W | H'07 | H'FFF0 |
| System control register 2 | SYSCR2 | R/W | H'F0 | H'FFF1 |

1. System control register 1 (SYSCR1)

| Bit | 7 | 6 | 5 | 4 | 3 | 2 | 1 | 0 |
|---------------|------|------|------|------|------|---|-----|-----|
| | SSBY | STS2 | STS1 | STS0 | LSON | — | MA1 | MA0 |
| Initial value | 0 | 0 | 0 | 0 | 0 | 1 | 1 | 1 |
| Read/Write | R/W | R/W | R/W | R/W | R/W | — | R/W | R/W |

SYSCR1 is an 8-bit read/write register for control of the power-down modes.

Upon reset, SYSCR1 is initialized to H'07.

Bit 7: Software standby (SSBY)

This bit designates transition to standby mode or watch mode.

Bit 7

| SSBY | Description |
|------|---|
| 0 | <ul style="list-style-type: none">When a SLEEP instruction is executed in active mode, a transition is made to sleep mode (initial value)When a SLEEP instruction is executed in subactive mode, a transition is made to subsleep mode |
| 1 | <ul style="list-style-type: none">When a SLEEP instruction is executed in active mode, a transition is made to standby mode or watch modeWhen a SLEEP instruction is executed in subactive mode, a transition is made to watch mode |

Bits 6 to 4: Standby timer select 2 to 0 (STS2 to STS0)

These bits designate the time the CPU and peripheral modules wait for stable clock operation after exiting from standby mode or watch mode to active mode due to an interrupt. The designation should be made according to the operating frequency so that the waiting time is at least equal to the oscillation settling time.

| Bit 6 STS2 | Bit 5 STS1 | Bit 4 STS0 | Description |
|---------------|---------------|---------------|--|
| 0 | 0 | 0 | Wait time = 8,192 states (initial value) |
| 0 | 0 | 1 | Wait time = 16,384 states |
| 0 | 1 | 0 | Wait time = 32,768 states |
| 0 | 1 | 1 | Wait time = 65,536 states |
| 1 | 0 | 0 | Wait time = 131,072 states |
| 1 | 0 | 1 | Wait time = 2 states (External clock mode) |
| 1 | 1 | 0 | Wait time = 8 states |
| 1 | 1 | 1 | Wait time = 16 states |

Note: In the case that external clock is input, set up the “Standby timer select” selection to External clock mode before Mode Transition. Also, do not set up to external clock mode, in the case that it does not use external clock.

Bit 3: Low speed on flag (LSON)

This bit chooses the system clock (ϕ) or subclock (ϕ_{SUB}) as the CPU operating clock when watch mode is cleared. The resulting operation mode depends on the combination of other control bits and interrupt input.

Bit 3

| LSON | Description |
|------|---|
| 0 | The CPU operates on the system clock (ϕ) (initial value) |
| 1 | The CPU operates on the subclock (ϕ_{SUB}) |

Bits 2: Reserved bits

Bit 2 is reserved: it is always read as 1 and cannot be modified.

Bits 1 and 0: Active (medium-speed) mode clock select (MA1, MA0)

Bits 1 and 0 choose $\phi_{OSC}/128$, $\phi_{OSC}/64$, $\phi_{OSC}/32$, or $\phi_{OSC}/16$ as the operating clock in active (medium-speed) mode and sleep (medium-speed) mode. MA1 and MA0 should be written in active (high-speed) mode or subactive mode.

| Bit 1 MA1 | Bit 0 MA0 | Description |
|--------------|--------------|----------------------------------|
| 0 | 0 | $\phi_{OSC}/16$ |
| 0 | 1 | $\phi_{OSC}/32$ |
| 1 | 0 | $\phi_{OSC}/64$ |
| 1 | 1 | $\phi_{OSC}/128$ (initial value) |

2. System control register 2 (SYSCR2)

| Bit | 7 | 6 | 5 | 4 | 3 | 2 | 1 | 0 |
|---------------|---|---|---|-------|------|------|-----|-----|
| | — | — | — | NESEL | DTON | MSON | SA1 | SA0 |
| Initial value | 1 | 1 | 1 | 1 | 0 | 0 | 0 | 0 |
| Read/Write | — | — | — | R/W | R/W | R/W | R/W | R/W |

SYSCR2 is an 8-bit read/write register for power-down mode control.

Bits 7 to 5: Reserved bits

These bits are reserved; they are always read as 1, and cannot be modified.

Bit 4: Noise elimination sampling frequency select (NESEL)

This bit selects the frequency at which the watch clock signal (ϕ_W) generated by the subclock pulse generator is sampled, in relation to the oscillator clock (ϕ_{OSC}) generated by the system clock pulse generator. When $\phi_{OSC} = 2$ to 6 MHz, clear NESEL to 0.

Bit 4

| NESEL | Description |
|-------|---|
| 0 | Sampling rate is $\phi_{OSC}/16$ |
| 1 | Sampling rate is $\phi_{OSC}/4$ (initial value) |

Bit 3: Direct transfer on flag (DTON)

This bit designates whether or not to make direct transitions among active (high-speed), active (medium-speed) and subactive mode when a SLEEP instruction is executed. The mode to which the transition is made after the SLEEP instruction is executed depends on a combination of this and other control bits.

Bit 3

DTON

Description

| DTON | Description |
|------|---|
| 0 | <ul style="list-style-type: none">When a SLEEP instruction is executed in active mode, (initial value) a transition is made to standby mode, watch mode, or sleep modeWhen a SLEEP instruction is executed in subactive mode, a transition is made to watch mode or subsleep mode |
| 1 | <ul style="list-style-type: none">When a SLEEP instruction is executed in active (high-speed) mode, a direct transition is made to active (medium-speed) mode if SSBY = 0, MSON = 1, and LSON = 0, or to subactive mode if SSBY = 1, TMA3 = 1, and LSON = 1When a SLEEP instruction is executed in active (medium-speed) mode, a direct transition is made to active (high-speed) mode if SSBY = 0, MSON = 0, and LSON = 0, or to subactive mode if SSBY = 1, TMA3 = 1, and LSON = 1When a SLEEP instruction is executed in subactive mode, a direct transition is made to active (high-speed) mode if SSBY = 1, TMA3 = 1, LSON = 0, and MSON = 0, or to active (medium-speed) mode if SSBY = 1, TMA3 = 1, LSON = 0, and MSON = 1 |

Bit 2: Medium speed on flag (MSON)

After standby, watch, or sleep mode is cleared, this bit selects active (high-speed) or active (medium-speed) mode.

Bit 2

MSON

Description

| | |
|---|---|
| 0 | Operation in active (high-speed) mode (initial value) |
| 1 | Operation in active (medium-speed) mode |

Bits 1 and 0: Subactive mode clock select (SA1 and SA0)

These bits select the CPU clock rate ($\phi_W/2$, $\phi_W/4$, or $\phi_W/8$) in subactive mode. SA1 and SA0 cannot be modified in subactive mode.

| Bit 1 SA1 | Bit 0 SA0 | Description |
|--------------|--------------|----------------------------|
| 0 | 0 | $\phi_W/8$ (initial value) |
| 0 | 1 | $\phi_W/4$ |
| 1 | * | $\phi_W/2$ |

* : Don't care

5.2 Sleep Mode

5.2.1 Transition to Sleep Mode

1. Transition to sleep (high-speed) mode

The system goes from active mode to sleep (high-speed) mode when a SLEEP instruction is executed while the SSBY and LSON bits in SYSCR1 are cleared to 0, the MSON and DTON bits in SYSCR2 are cleared to 0. In sleep mode CPU operation is halted but the on-chip peripheral functions. CPU register contents are retained.

2. Transition to sleep (medium-speed) mode

The system goes from active mode to sleep (medium-speed) mode when a SLEEP instruction is executed while the SSBY and LSON bits in SYSCR1 are cleared to 0, the MSON bit in SYSCR2 is set to 1, and the DTON bit in SYSCR2 is cleared to 0. In sleep (medium-speed) mode, as in sleep (high-speed) mode, CPU operation is halted but the on-chip peripheral functions are operational. The clock frequency in sleep (medium-speed) mode is determined by the MA1 and MA0 bits in SYSCR1. CPU register contents are retained.

Furthermore, it sometimes acts with half state early timing at the time of transition to sleep (medium-speed) mode.

5.2.2 Clearing Sleep Mode

Sleep mode is cleared by any interrupt (timer A, timer C, timer F, timer G, asynchronous counter, IRQ₄ to IRQ₀, WKP₇ to WKP₀, SCI3-1, SCI3-2, A/D converter, or), or by input at the $\overline{\text{RES}}$ pin.

- Clearing by interrupt

When an interrupt is requested, sleep mode is cleared and interrupt exception handling starts. A transition is made from sleep (high-speed) mode to active (high-speed) mode, or from sleep (medium-speed) mode to active (medium-speed) mode. Sleep mode is not cleared if the I bit of the condition code register (CCR) is set to 1 or the particular interrupt is disabled in the interrupt enable register.

Interrupt signal and system clock are mutually asynchronous. Synchronization error time in a maximum is $2/\phi$ (s).

- Clearing by $\overline{\text{RES}}$ input

When the $\overline{\text{RES}}$ pin goes low, the CPU goes into the reset state and sleep mode is cleared.

5.2.3 Clock Frequency in Sleep (Medium-Speed) Mode

Operation in sleep (medium-speed) mode is clocked at the frequency designated by the MA1 and MA0 bits in SYSCR1.

5.3 Standby Mode

5.3.1 Transition to Standby Mode

The system goes from active mode to standby mode when a SLEEP instruction is executed while the SSBY bit in SYSCR1 is set to 1, the LSON bit in SYSCR1 is cleared to 0, and bit TMA3 in TMA is cleared to 0. In standby mode the clock pulse generator stops, so the CPU and on-chip peripheral modules stop functioning, but as long as the rated voltage is supplied, the contents of CPU registers, on-chip RAM, and some on-chip peripheral module registers are retained. On-chip RAM contents will be further retained down to a minimum RAM data retention voltage. The I/O ports go to the high-impedance state.

5.3.2 Clearing Standby Mode

Standby mode is cleared by an interrupt (IRQ₁ or IRQ₀), WKP₇ to WKP₀ or by input at the $\overline{\text{RES}}$ pin.

- Clearing by interrupt

When an interrupt is requested, the system clock pulse generator starts. After the time set in bits STS2 to STS0 in SYSCR1 has elapsed, a stable system clock signal is supplied to the entire chip, standby mode is cleared, and interrupt exception handling starts. Operation resumes in active (high-speed) mode if MSON = 0 in SYSCR2, or active (medium-speed) mode if MSON = 1. Standby mode is not cleared if the I bit of CCR is set to 1 or the particular interrupt is disabled in the interrupt enable register.

- Clearing by $\overline{\text{RES}}$ input

When the $\overline{\text{RES}}$ pin goes low, the system clock pulse generator starts. After the pulse generator output has stabilized, if the $\overline{\text{RES}}$ pin is driven high, the CPU starts reset exception handling. Since system clock signals are supplied to the entire chip as soon as the system clock pulse generator starts functioning, the $\overline{\text{RES}}$ pin should be kept at the low level until the pulse generator output stabilizes.

5.3.3 Oscillator Settling Time after Standby Mode is Cleared

Bits STS2 to STS0 in SYSCR1 should be set as follows.

- When a crystal oscillator is used

The table below gives settings for various operating frequencies. Set bits STS2 to STS0 for a waiting time at least as long as the oscillation settling time.

Table 5.4 Clock Frequency and Settling Time (times are in ms)

| STS2 | STS1 | STS0 | Waiting Time | 2 MHz | 1 MHz | 0.5 MHz |
|------|------|------|------------------------------|-------|-------|---------|
| 0 | 0 | 0 | 8,192 states | 4.1 | 8.2 | 16.4 |
| 0 | 0 | 1 | 16,384 states | 8.2 | 16.4 | 32.8 |
| 0 | 1 | 0 | 32,768 states | 16.4 | 32.8 | 65.5 |
| 0 | 1 | 1 | 65,536 states | 32.8 | 65.5 | 131.1 |
| 1 | 0 | 0 | 131,072 states | 65.5 | 131.1 | 262.1 |
| 1 | 0 | 1 | 2 states (Use prohibited) | 0.001 | 0.002 | 0.004 |
| 1 | 1 | 0 | 8 states | 0.004 | 0.008 | 0.016 |
| 1 | 1 | 1 | 16 states | 0.008 | 0.016 | 0.032 |

- When an external clock is used

STS2 = 1, STS1 = 0, and STS0 = 1 should be set. Other values possible use, but CPU sometimes will start operation before waiting time completion.

5.3.4 Standby Mode Transition and Pin States

When a SLEEP instruction is executed in active (high-speed) mode or active (medium-speed) mode while bit SSBY is set to 1 and bit LSON is cleared to 0 in SYSCR1, and bit TMA3 is cleared to 0 in TMA, a transition is made to standby mode. At the same time, pins go to the high-impedance state (except pins for which the pull-up MOS is designated as on). Figure 5.2 shows the timing in this case.

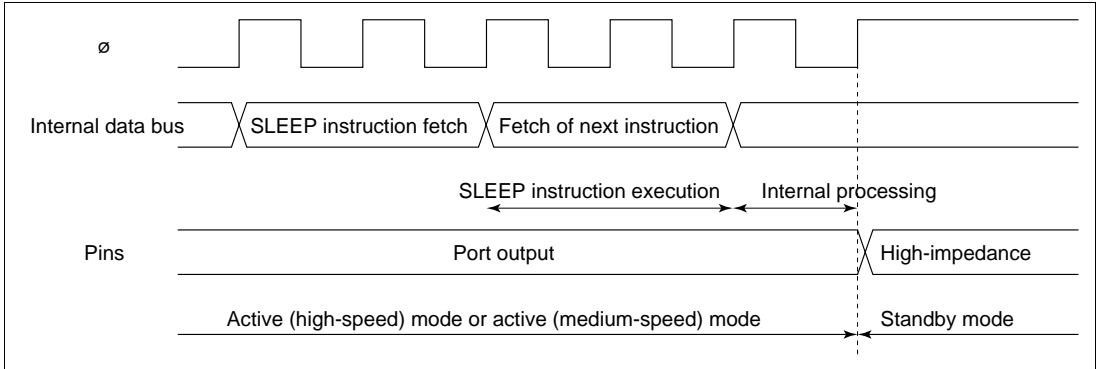

Figure 5.2 Standby Mode Transition and Pin States

5.4 Watch Mode

5.4.1 Transition to Watch Mode

The system goes from active or subactive mode to watch mode when a SLEEP instruction is executed while the SSBY bit in SYSCR1 is set to 1 and bit TMA3 in TMA is set to 1.

In watch mode, operation of on-chip peripheral modules is halted except for timer A, timer F, timer G, AEC and the LCD controller/driver (for which operation or halting can be set) is halted. As long as a minimum required voltage is applied, the contents of CPU registers, the on-chip RAM and some registers of the on-chip peripheral modules, are retained. I/O ports keep the same states as before the transition.

5.4.2 Clearing Watch Mode

Watch mode is cleared by an interrupt (timer A, timer F, timer G, IRQ₀, or WKP₇ to WKP₀) or by input at the $\overline{\text{RES}}$ pin.

- Clearing by interrupt

When watch mode is cleared by interrupt, the mode to which a transition is made depends on the settings of LSON in SYSCR1 and MSON in SYSCR2. If both LSON and MSON are cleared to 0, transition is to active (high-speed) mode; if LSON = 0 and MSON = 1, transition is to active (medium-speed) mode; if LSON = 1, transition is to subactive mode. When the transition is to active mode, after the time set in SYSCR1 bits STS2 to STS0 has elapsed, a stable clock signal is supplied to the entire chip, watch mode is cleared, and interrupt exception handling starts. Watch mode is not cleared if the I bit of CCR is set to 1 or the particular interrupt is disabled in the interrupt enable register.

- Clearing by $\overline{\text{RES}}$ input

Clearing by $\overline{\text{RES}}$ pin is the same as for standby mode; see 2. Clearing by $\overline{\text{RES}}$ pin in 5.3.2, Clearing Standby Mode.

5.4.3 Oscillator Settling Time after Watch Mode is Cleared

The waiting time is the same as for standby mode; see 5.3.3, Oscillator Settling Time after Standby Mode is Cleared.

5.5 Subsleap Mode

5.5.1 Transition to Subsleap Mode

The system goes from subactive mode to subsleap mode when a SLEEP instruction is executed while the SSBY bit in SYSCR1 is cleared to 0, LSON bit in SYSCR1 is set to 1, and TMA3 bit in TMA is set to 1. In subsleap mode, operation of on-chip peripheral modules other than the A/D converter WDT and PWM is halted. As long as a minimum required voltage is applied, the contents of CPU registers, the on-chip RAM and some registers of the on-chip peripheral modules are retained. I/O ports keep the same states as before the transition.

5.5.2 Clearing Subsleap Mode

Subsleap mode is cleared by an interrupt (timer A, timer C, timer F, timer G, asynchronous counter, SCI3-2, SCI3-1, IRQ₄ to IRQ₀, WKP₇ to WKP₀) or by a low input at the $\overline{\text{RES}}$ pin.

- Clearing by interrupt

When an interrupt is requested, subsleap mode is cleared and interrupt exception handling starts. Subsleap mode is not cleared if the I bit of CCR is set to 1 or the particular interrupt is disabled in the interrupt enable register.

Interrupt signal and system clock are mutually asynchronous. Synchronization error time in a maximum is $2/\phi$ (s).

- Clearing by $\overline{\text{RES}}$ input

Clearing by $\overline{\text{RES}}$ pin is the same as for standby mode; see 2. Clearing by $\overline{\text{RES}}$ pin in 5.3.2, Clearing Standby Mode.

5.6 Subactive Mode

5.6.1 Transition to Subactive Mode

Subactive mode is entered from watch mode if a timer A, timer F, timer G, IRQ₀, or WKP₇ to WKP₀ interrupt is requested while the LSON bit in SYSCR1 is set to 1. From subsleep mode, subactive mode is entered if a timer A, timer C, timer F, timer G, asynchronous counter, SCI3-1, SCI3-2, IRQ₄ to IRQ₀, or WKP₇ to WKP₀ interrupt is requested. A transition to subactive mode does not take place if the I bit of CCR is set to 1 or the particular interrupt is disabled in the interrupt enable register.

5.6.2 Clearing Subactive Mode

Subactive mode is cleared by a SLEEP instruction or by a low input at the $\overline{\text{RES}}$ pin.

- Clearing by SLEEP instruction

If a SLEEP instruction is executed while the SSBY bit in SYSCR1 is set to 1 and TMA3 bit in TMA is set to 1, subactive mode is cleared and watch mode is entered. If a SLEEP instruction is executed while SSBY = 0 and LSON = 1 in SYSCR1 and TMA3 = 1 in TMA, subsleep mode is entered. Direct transfer to active mode is also possible; see 5.8, Direct Transfer, below.

- Clearing by $\overline{\text{RES}}$ pin

Clearing by $\overline{\text{RES}}$ pin is the same as for standby mode; see 2. Clearing by $\overline{\text{RES}}$ pin in 5.3.2, Clearing Standby Mode.

5.6.3 Operating Frequency in Subactive Mode

The operating frequency in subactive mode is set in bits SA1 and SA0 in SYSCR2. The choices are $\phi_W/2$, $\phi_W/4$, and $\phi_W/8$.

5.7 Active (Medium-Speed) Mode

5.7.1 Transition to Active (Medium-Speed) Mode

If the $\overline{\text{RES}}$ pin is driven low, active (medium-speed) mode is entered. If the LSON bit in SYSCR2 is set to 1 while the LSON bit in SYSCR1 is cleared to 0, a transition to active (medium-speed) mode results from IRQ₀, IRQ₁ or WKP₇ to WKP₀ interrupts in standby mode, timer A, timer F, timer G, IRQ₀ or WKP₇ to WKP₀ interrupts in watch mode, or any interrupt in sleep mode. A transition to active (medium-speed) mode does not take place if the I bit of CCR is set to 1 or the particular interrupt is disabled in the interrupt enable register.

Furthermore, it sometimes acts with half state early timing at the time of transition to active (medium-speed) mode.

5.7.2 Clearing Active (Medium-Speed) Mode

Active (medium-speed) mode is cleared by a SLEEP instruction.

- Clearing by SLEEP instruction

A transition to standby mode takes place if the SLEEP instruction is executed while the SSBY bit in SYSCR1 is set to 1, the LSON bit in SYSCR1 is cleared to 0, and the TMA3 bit in TMA is cleared to 0. The system goes to watch mode if the SSBY bit in SYSCR1 is set to 1 and bit TMA3 in TMA is set to 1 when a SLEEP instruction is executed.

When both SSBY and LSON are cleared to 0 in SYSCR1 and a SLEEP instruction is executed, sleep mode is entered. Direct transfer to active (high-speed) mode or to subactive mode is also possible. See 5.8, Direct Transfer, below for details.

- Clearing by $\overline{\text{RES}}$ pin

When the $\overline{\text{RES}}$ pin is driven low, a transition is made to the reset state and active (medium-speed) mode is cleared.

5.7.3 Operating Frequency in Active (Medium-Speed) Mode

Operation in active (medium-speed) mode is clocked at the frequency designated by the MA1 and MA0 bits in SYSCR1.

5.8 Direct Transfer

5.8.1 Overview of Direct Transfer

The CPU can execute programs in three modes: active (high-speed) mode, active (medium-speed) mode, and subactive mode. A direct transfer is a transition among these three modes without the stopping of program execution. A direct transfer can be made by executing a SLEEP instruction while the DTON bit in SYSCR2 is set to 1. After the mode transition, direct transfer interrupt exception handling starts.

If the direct transfer interrupt is disabled in interrupt enable register 2, a transition is made instead to sleep mode or watch mode. Note that if a direct transition is attempted while the I bit in CCR is set to 1, sleep mode or watch mode will be entered, and it will be impossible to clear the resulting mode by means of an interrupt.

- Direct transfer from active (high-speed) mode to active (medium-speed) mode

When a SLEEP instruction is executed in active (high-speed) mode while the SSBY and LSON bits in SYSCR1 are cleared to 0, the MSON bit in SYSCR2 is set to 1, and the DTON bit in SYSCR2 is set to 1, a transition is made to active (medium-speed) mode via sleep mode.

- Direct transfer from active (medium-speed) mode to active (high-speed) mode

When a SLEEP instruction is executed in active (medium-speed) mode while the SSBY and LSON bits in SYSCR1 are cleared to 0, the MSON bit in SYSCR2 is cleared to 0, and the DTON bit in SYSCR2 is set to 1, a transition is made to active (high-speed) mode via sleep mode.

- Direct transfer from active (high-speed) mode to subactive mode

When a SLEEP instruction is executed in active (high-speed) mode while the SSBY and LSON bits in SYSCR1 are set to 1, the DTON bit in SYSCR2 is set to 1, and the TMA3 bit in TMA is set to 1, a transition is made to subactive mode via watch mode.

- Direct transfer from subactive mode to active (high-speed) mode

When a SLEEP instruction is executed in subactive mode while the SSBY bit in SYSCR1 is set to 1, the LSON bit in SYSCR1 is cleared to 0, the MSON bit in SYSCR2 is cleared to 0, the DTON bit in SYSCR2 is set to 1, and the TMA3 bit in TMA is set to 1, a transition is made directly to active (high-speed) mode via watch mode after the waiting time set in SYSCR1 bits STS2 to STS0 has elapsed.

- Direct transfer from active (medium-speed) mode to subactive mode

When a SLEEP instruction is executed in active (medium-speed) while the SSBY and LSON bits in SYSCR1 are set to 1, the DTON bit in SYSCR2 is set to 1, and the TMA3 bit in TMA is set to 1, a transition is made to subactive mode via watch mode.

- Direct transfer from subactive mode to active (medium-speed) mode

When a SLEEP instruction is executed in subactive mode while the SSBY bit in SYSCR1 is set to 1, the LSON bit in SYSCR1 is cleared to 0, the MSON bit in SYSCR2 is set to 1, the DTON bit in SYSCR2 is set to 1, and the TMA3 bit in TMA is set to 1, a transition is made directly to active (medium-speed) mode via watch mode after the waiting time set in SYSCR1 bits STS2 to STS0 has elapsed.

5.8.2 Direct Transition Times

1. Time for direct transition from active (high-speed) mode to active (medium-speed) mode

A direct transition from active (high-speed) mode to active (medium-speed) mode is performed by executing a SLEEP instruction in active (high-speed) mode while bits SSBY and LSON are both cleared to 0 in SYSCR1, and bits MSON and DTON are both set to 1 in SYSCR2. The time from execution of the SLEEP instruction to the end of interrupt exception handling (the direct transition time) is given by equation (1) below.

$$\text{Direct transition time} = \{ (\text{Number of SLEEP instruction execution states}) + (\text{number of internal processing states}) \} \times (\text{tcyc before transition}) + (\text{number of interrupt exception handling execution states}) \times (\text{tcyc after transition}) \dots\dots\dots (1)$$

Example: Direct transition time = $(2 + 1) \times 2\text{tosc} + 14 \times 16\text{tosc} = 230\text{tosc}$ (when $\phi/8$ is selected as the CPU operating clock)

Notation:

tosc: OSC clock cycle time

tcyc: System clock (ϕ) cycle time

2. Time for direct transition from active (medium-speed) mode to active (high-speed) mode

A direct transition from active (medium-speed) mode to active (high-speed) mode is performed by executing a SLEEP instruction in active (medium-speed) mode while bits SSBY and LSON are both cleared to 0 in SYSCR1, and bit MSON is cleared to 0 and bit DTON is set to 1 in SYSCR2. The time from execution of the SLEEP instruction to the end of interrupt exception handling (the direct transition time) is given by equation (2) below.

$$\text{Direct transition time} = \{ (\text{Number of SLEEP instruction execution states}) + (\text{number of internal processing states}) \} \times (\text{tcyc before transition}) + (\text{number of interrupt exception handling execution states}) \times (\text{tcyc after transition}) \dots\dots\dots (2)$$

Example: Direct transition time = $(2 + 1) \times 16\text{tosc} + 14 \times 2\text{tosc} = 76\text{tosc}$ (when $\phi/8$ is selected as the CPU operating clock)

Notation:

tosc: OSC clock cycle time

tcyc: System clock (ϕ) cycle time

3. Time for direct transition from subactive mode to active (high-speed) mode

A direct transition from subactive mode to active (high-speed) mode is performed by executing a SLEEP instruction in subactive mode while bit SSBY is set to 1 and bit LSON is cleared to 0 in SYSCR1, bit MSON is cleared to 0 and bit DTON is set to 1 in SYSCR2, and bit TMA3 is set to 1 in TMA. The time from execution of the SLEEP instruction to the end of interrupt exception handling (the direct transition time) is given by equation (3) below.

$$\text{Direct transition time} = \{ (\text{Number of SLEEP instruction execution states}) + (\text{number of internal processing states}) \} \times (\text{tsubcyc before transition}) + \{ (\text{wait time set in STS2 to STS0}) + (\text{number of interrupt exception handling execution states}) \} \times (\text{tcyc after transition}) \dots\dots\dots (3)$$

Example: Direct transition time = $(2 + 1) \times 8\text{tw} + (8192 + 14) \times 2\text{tosc} = 24\text{tw} + 16412\text{tosc}$ (when $\phi_w/8$ is selected as the CPU operating clock, and wait time = 8192 states)

Notation:

tosc: OSC clock cycle time

tw: Watch clock cycle time

tcyc: System clock (ϕ) cycle time

tsubcyc: Subclock (ϕ_{SUB}) cycle time

4. Time for direct transition from subactive mode to active (medium-speed) mode

A direct transition from subactive mode to active (medium-speed) mode is performed by executing a SLEEP instruction in subactive mode while bit SSBY is set to 1 and bit LSON is cleared to 0 in SYSCR1, bits MSON and DTON are both set to 1 in SYSCR2, and bit TMA3 is set to 1 in TMA. The time from execution of the SLEEP instruction to the end of interrupt exception handling (the direct transition time) is given by equation (4) below.

$$\text{Direct transition time} = \{ (\text{Number of SLEEP instruction execution states}) + (\text{number of internal processing states}) \} \times (\text{tsubcyc before transition}) + \{ (\text{wait time set in STS2 to STS0}) + (\text{number of interrupt exception handling execution states}) \} \times (\text{tcyc after transition}) \dots\dots\dots (4)$$

Example: Direct transition time = $(2 + 1) \times 8tw + (8192 + 14) \times 16tosc = 24tw + 131296tosc$
(when $\phi w/8$ or $\phi 8$ is selected as the CPU operating clock, and wait time = 8192 states)

Notation:

- tosc: OSC clock cycle time
- tw: Watch clock cycle time
- tcyc: System clock (ϕ) cycle time
- tsubcyc: Subclock (ϕ SUB) cycle time

5.9 Module Standby Mode

5.9.1 Setting Module Standby Mode

Module standby mode is set for individual peripheral functions. All the on-chip peripheral modules can be placed in module standby mode. When a module enters module standby mode, the system clock supply to the module is stopped and operation of the module halts. This state is identical to standby mode.

Module standby mode is set for a particular module by setting the corresponding bit to 0 in clock stop register 1 (CKSTPR1) or clock stop register 2 (CKSTPR2). (See table 5.5.)

5.9.2 Clearing Module Standby Mode

Module standby mode is cleared for a particular module by setting the corresponding bit to 1 in clock stop register 1 (CKSTPR1) or clock stop register 2 (CKSTPR2). (See table 5.5.)

Following a reset, clock stop register 1 (CKSTPR1) and clock stop register 2 (CKSTPR2) are both initialized to H'FF.

Table 5.5

| Register Name | Bit Name | | Operation |
|---------------|----------|---|--|
| CKSTPR1 | TACKSTP | 1 | Timer A module standby mode is cleared |
| | | 0 | Timer A is set to module standby mode |
| | TCCKSTP | 1 | Timer C module standby mode is cleared |
| | | 0 | Timer C is set to module standby mode |
| | TFCKSTP | 1 | Timer F module standby mode is cleared |
| | | 0 | Timer F is set to module standby mode |
| | TGCKSTP | 1 | Timer G module standby mode is cleared |
| | | 0 | Timer G is set to module standby mode |
| | ADCKSTP | 1 | A/D converter module standby mode is cleared |
| | | 0 | A/D converter is set to module standby mode |
| | S32CKSTP | 1 | SCI3-2 module standby mode is cleared |
| | | 0 | SCI3-2 is set to module standby mode |
| | S31CKSTP | 1 | SCI3-1 module standby mode is cleared |
| | | 0 | SCI3-1 is set to module standby mode |

Table 5.5 (cont)

| Register Name | Bit Name | | Operation |
|----------------------|-----------------|---|---|
| CKSTPR2 | LDCKSTP | 1 | LCD module standby mode is cleared |
| | | 0 | LCD is set to module standby mode |
| | PWCKSTP | 1 | PWM module standby mode is cleared |
| | | 0 | PWM is set to module standby mode |
| | WDCKSTP | 1 | Watchdog timer module standby mode is cleared |
| | | 0 | Watchdog timer is set to module standby mode |
| | AECKSTP | 1 | Asynchronous event counter module standby mode is cleared |
| | | 0 | Asynchronous event counter is set to module standby mode |

Note: For details of module operation, see the sections on the individual modules.

6.2 H8/3867 and H8/3827 PROM Mode

6.2.1 Setting to PROM Mode

If the on-chip ROM is PROM, setting the chip to PROM mode stops operation as a microcontroller and allows the PROM to be programmed in the same way as the standard HN27C101 EPROM. However, page programming is not supported. Table 6.1 shows how to set the chip to PROM mode.

Table 6.1 Setting to PROM Mode

| Pin Name | Setting |
|----------------------------------|----------------|
| TEST | High level |
| PB ₄ /AN ₄ | Low level |
| PB ₅ /AN ₅ | |
| PB ₆ /AN ₆ | High level |

6.2.2 Socket Adapter Pin Arrangement and Memory Map

A standard PROM programmer can be used to program the PROM. A socket adapter is required for conversion to 32 pins, as listed in table 6.2.

Figure 6.2 shows the pin-to-pin wiring of the socket adapter. Figure 6.3 shows a memory map.

Table 6.2 Socket Adapter

| Package | Socket Adapters (Manufacturer) |
|------------------|---|
| 80-pin (FP-80B) | ME3867ESFS1H (MINATO) H7386BQ080D3201 (DATA-I/O) |
| 80-pin (FP-80A) | ME3867ESHS1H (MINATO) H7386AQ080D3201 (DATA-I/O) |
| 80-pin (TFP-80C) | ME3867ESNS1H (MINATO) H7386CT080D3201 (DATA-I/O) |

| FP-80A, TFP-80C | FP-80B | Pin | Pin | HN27C101 (32-pin) |
|-----------------|--------|------------------------------------|-----|---------------------|
| 9 | 11 | RES | | V _{PP} 1 |
| 45 | 47 | P6 ₀ | | EO ₀ 13 |
| 46 | 48 | P6 ₁ | | EO ₁ 14 |
| 47 | 49 | P6 ₂ | | EO ₂ 15 |
| 48 | 50 | P6 ₃ | | EO ₃ 17 |
| 49 | 51 | P6 ₄ | | EO ₄ 18 |
| 50 | 52 | P6 ₅ | | EO ₅ 19 |
| 51 | 53 | P6 ₆ | | EO ₆ 20 |
| 52 | 54 | P6 ₇ | | EO ₇ 21 |
| 68 | 70 | P8 ₇ | | EA ₀ 12 |
| 67 | 69 | P8 ₆ | | EA ₁ 11 |
| 66 | 68 | P8 ₅ | | EA ₂ 10 |
| 65 | 67 | P8 ₄ | | EA ₃ 9 |
| 64 | 66 | P8 ₃ | | EA ₄ 8 |
| 63 | 65 | P8 ₂ | | EA ₅ 7 |
| 62 | 64 | P8 ₁ | | EA ₆ 6 |
| 61 | 63 | P8 ₀ | | EA ₇ 5 |
| 53 | 55 | P7 ₀ | | EA ₈ 27 |
| 72 | 74 | P4 ₃ | | EA ₉ 26 |
| 55 | 57 | P7 ₂ | | EA ₁₀ 23 |
| 56 | 58 | P7 ₃ | | EA ₁₁ 25 |
| 57 | 59 | P7 ₄ | | EA ₁₂ 4 |
| 58 | 60 | P7 ₅ | | EA ₁₃ 28 |
| 59 | 61 | P7 ₆ | | EA ₁₄ 29 |
| 14 | 16 | P1 ₄ | | EA ₁₅ 3 |
| 15 | 17 | P1 ₅ | | EA ₁₆ 2 |
| 60 | 62 | P7 ₇ | | CE 22 |
| 54 | 56 | P7 ₁ | | OE 24 |
| 13 | 15 | P1 ₃ | | PGM 31 |
| 32, 26 | 34, 28 | V _{CC} , CV _{CC} | | V _{CC} 32 |
| 73 | 75 | AV _{CC} | | |
| 8 | 10 | TEST | | |
| 3 | 5 | X ₁ | | |
| 80 | 2 | PB ₆ | | |
| 11 | 13 | P1 ₁ | | |
| 12 | 14 | P1 ₂ | | |
| 16 | 18 | P1 ₆ | | |
| 5, 27 | 7, 29 | V _{SS} | | V _{SS} 16 |
| 2 | 4 | AV _{SS} | | |
| 78 | 80 | PB ₄ | | |
| 79 | 1 | PB ₅ | | |

Note: Pins not indicated in the figure should be left open.

Figure 6.2 Socket Adapter Pin Correspondence (with HN27C101)

Address in
MCU mode

Address in
PROM mode

H'0000

H'0000

On-chip PROM

H'EDFF

H'EDFF

Uninstalled area*

H'1FFFF

Note: * The output data is not guaranteed if this address area is read in PROM mode. Therefore, when programming with a PROM programmer, be sure to specify addresses from H'0000 to H'EDFF. If programming is inadvertently performed from H'EE00 onward, it may not be possible to continue PROM programming and verification.

When programming, H'FF should be set as the data in this address area (H'EE00 to H'1FFFF).

Figure 6.3 H8/3867 and H8/3827 Memory Map in PROM Mode

6.3 H8/3867 and H8/3827 Programming

The write, verify, and other modes are selected as shown in table 6.3 in H8/3867 and H8/3827 PROM mode.

Table 6.3 Mode Selection in PROM Mode (H8/3867, H8/3827)

| Mode | Pins | | | | | | |
|----------------------|------|----|-----|-----------------|-----------------|------------------------------------|-------------------------------------|
| | CE | OE | PGM | V _{PP} | V _{CC} | EO ₇ to EO ₀ | EA ₁₆ to EA ₀ |
| Write | L | H | L | V _{PP} | V _{CC} | Data input | Address input |
| Verify | L | L | H | V _{PP} | V _{CC} | Data output | Address input |
| Programming disabled | L | L | L | V _{PP} | V _{CC} | High impedance | Address input |
| | L | H | H | | | | |
| | H | L | L | | | | |
| | H | H | H | | | | |

Notation

L: Low level

H: High level

V_{PP}: V_{PP} level

V_{CC}: V_{CC} level

The specifications for writing and reading are identical to those for the standard HN27C101 EPROM. However, page programming is not supported, and so page programming mode must not be set. A PROM programmer that only supports page programming mode cannot be used. When selecting a PROM programmer, ensure that it supports high-speed, high-reliability byte-by-byte programming. Also, be sure to specify addresses from H'0000 to H'EDFF.

6.3.1 Writing and Verifying

An efficient, high-speed, high-reliability method is available for writing and verifying the PROM data. This method achieves high speed without voltage stress on the device and without lowering the reliability of written data. The basic flow of this high-speed, high-reliability programming method is shown in figure 6.4.

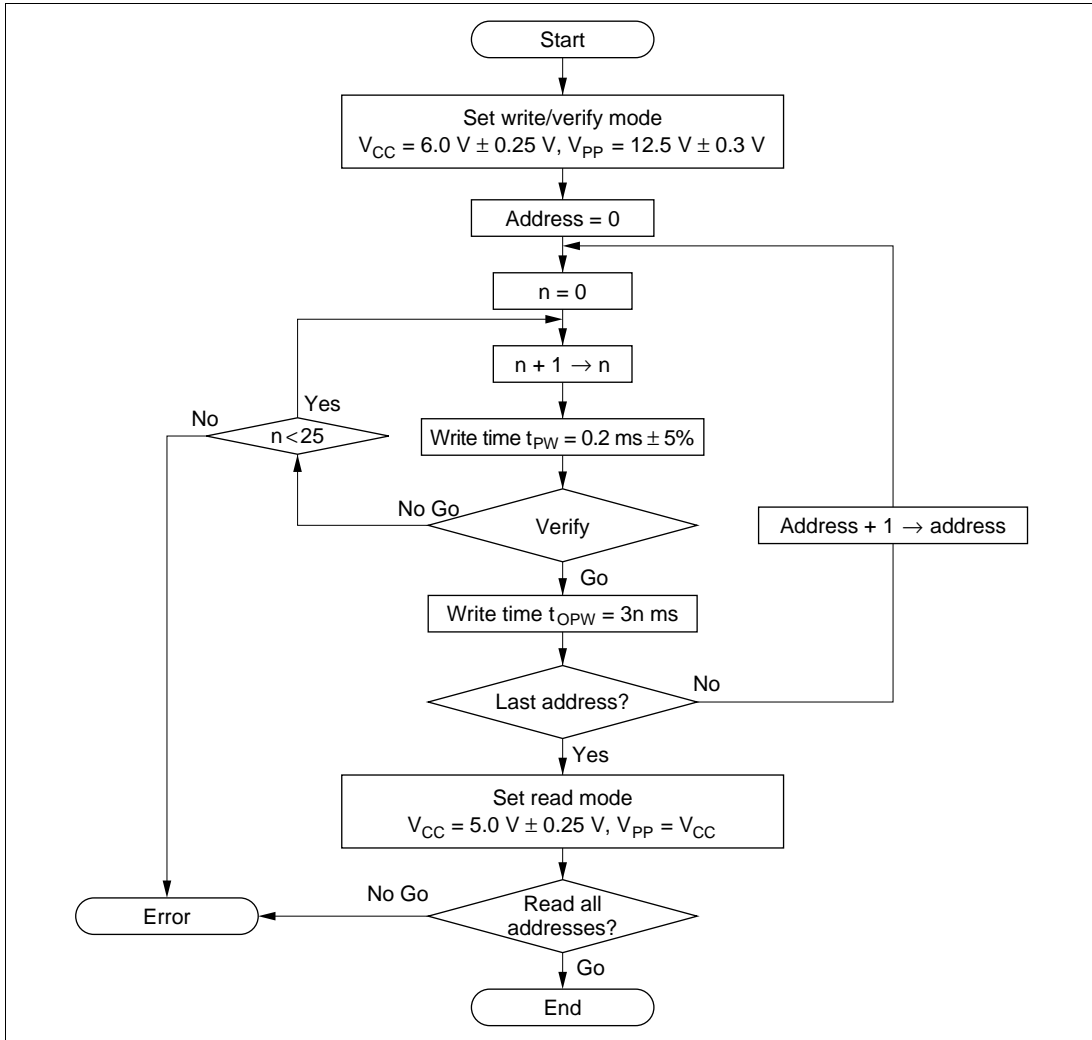

Figure 6.4 High-Speed, High-Reliability Programming Flow Chart

Table 6.4 and table 6.5 give the electrical characteristics in programming mode.

Table 6.4 DC Characteristics

(Conditions: $V_{CC} = 6.0 \text{ V} \pm 0.25 \text{ V}$, $V_{PP} = 12.5 \text{ V} \pm 0.3 \text{ V}$, $V_{SS} = 0 \text{ V}$, $T_a = 25^\circ\text{C} \pm 5^\circ\text{C}$)

| Item | | Symbol | Min | Typ | Max | Unit | Test Condition |
|---------------------------|---|------------|------|-----|----------------|---------------|---|
| Input high-level voltage | $\overline{EO_7}$ to $\overline{EO_0}$, $\overline{EA_{16}}$ to $\overline{EA_0}$ \overline{OE} , \overline{CE} , PGM | V_{IH} | 2.4 | — | $V_{CC} + 0.3$ | V | |
| Input low-level voltage | $\overline{EO_7}$ to $\overline{EO_0}$, $\overline{EA_{16}}$ to $\overline{EA_0}$ \overline{OE} , \overline{CE} , PGM | V_{IL} | -0.3 | — | 0.8 | V | |
| Output high-level voltage | $\overline{EO_7}$ to $\overline{EO_0}$ | V_{OH} | 2.4 | — | — | V | $I_{OH} = -200 \mu\text{A}$ |
| Output low-level voltage | $\overline{EO_7}$ to $\overline{EO_0}$ | V_{OL} | — | — | 0.45 | V | $I_{OL} = 0.8 \text{ mA}$ |
| Input leakage current | $\overline{EO_7}$ to $\overline{EO_0}$, $\overline{EA_{16}}$ to $\overline{EA_0}$ \overline{OE} , \overline{CE} , PGM | $ I_{Lj} $ | — | — | 2 | μA | $V_{in} = 5.25 \text{ V} / 0.5 \text{ V}$ |
| V_{CC} current | | I_{CC} | — | — | 40 | mA | |
| V_{PP} current | | I_{PP} | — | — | 40 | mA | |

Table 6.5 AC Characteristics(Conditions: $V_{CC} = 6.0 \text{ V} \pm 0.25 \text{ V}$, $V_{PP} = 12.5 \text{ V} \pm 0.3 \text{ V}$, $T_a = 25^\circ\text{C} \pm 5^\circ\text{C}$)

| Item | Symbol | Min | Typ | Max | Unit | Test Condition |
|---|-------------------------|------|------|------|---------------|--------------------------|
| Address setup time | t_{AS} | 2 | — | — | μs | Figure 6.5 ^{*1} |
| $\overline{\text{OE}}$ setup time | t_{OES} | 2 | — | — | μs | |
| Data setup time | t_{DS} | 2 | — | — | μs | |
| Address hold time | t_{AH} | 0 | — | — | μs | |
| Data hold time | t_{DH} | 2 | — | — | μs | |
| Data output disable time | t_{DF} ^{*2} | — | — | 130 | ns | |
| V_{PP} setup time | t_{VPS} | 2 | — | — | μs | |
| Programming pulse width | t_{PW} | 0.19 | 0.20 | 0.21 | ms | |
| PGM pulse width for overwrite programming | t_{OPW} ^{*3} | 0.19 | — | 5.25 | ms | |
| $\overline{\text{CE}}$ setup time | t_{CES} | 2 | — | — | μs | |
| V_{CC} setup time | t_{VCS} | 2 | — | — | μs | |
| Data output delay time | t_{OE} | 0 | — | 200 | ns | |

Notes: 1. Input pulse level: 0.45 V to 2.2 V

Input rise time/fall time 20 ns

Timing reference levels Input: 0.8 V, 2.0 V

Output: 0.8 V, 2.0 V

2. t_{DF} is defined at the point at which the output is floating and the output level cannot be read.
3. t_{OPW} is defined by the value given in figure 6.4, High-Speed, High-Reliability Programming Flow Chart.

Figure 6.5 shows a PROM write/verify timing diagram.

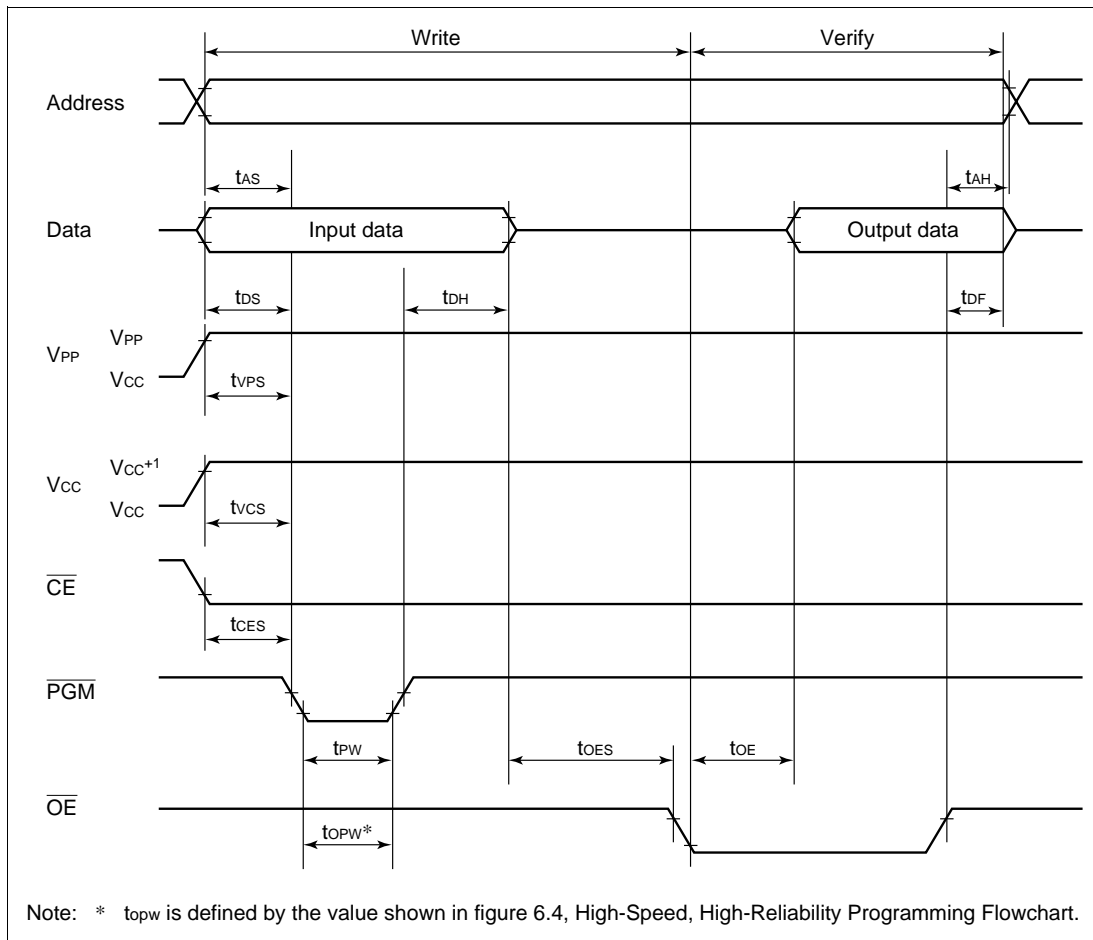

Figure 6.5 PROM Write/Verify Timing

6.3.2 Programming Precautions

- Use the specified programming voltage and timing.

The programming voltage in PROM mode (V_{PP}) is 12.5 V. Use of a higher voltage can permanently damage the chip. Be especially careful with respect to PROM programmer overshoot.

Setting the PROM programmer to Hitachi specifications for the HN27C101 will result in correct V_{PP} of 12.5 V.

- Make sure the index marks on the PROM programmer socket, socket adapter, and chip are properly aligned. If they are not, the chip may be destroyed by excessive current flow. Before programming, be sure that the chip is properly mounted in the PROM programmer.
- Avoid touching the socket adapter or chip while programming, since this may cause contact faults and write errors.
- Take care when setting the programming mode, as page programming is not supported.
- When programming with a PROM programmer, be sure to specify addresses from H'0000 to H'EDFF. If programming is inadvertently performed from H'EE00 onward, it may not be possible to continue PROM programming and verification. When programming, H'FF should be set as the data in address area H'EE00 to H'1FFFF.

6.4 Reliability of Programmed Data

A highly effective way to improve data retention characteristics is to bake the programmed chips at 150°C, then screen them for data errors. This procedure quickly eliminates chips with PROM memory cells prone to early failure.

Figure 6.6 Shows the recommended screening procedure.

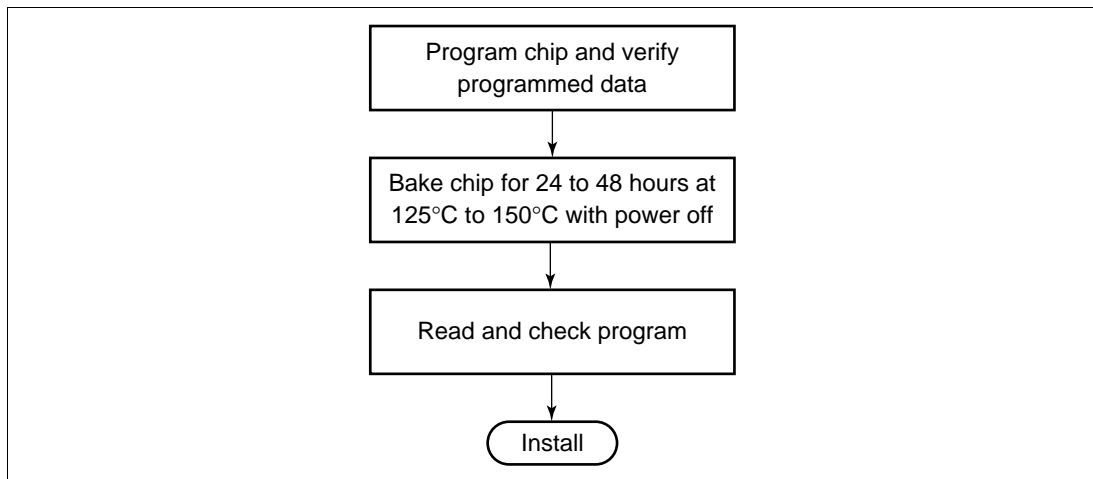

Figure 6.6 Recommended Screening Procedure

If a series of programming errors occurs while the same PROM programmer is in use, stop programming and check the PROM programmer and socket adapter for defects. Please inform Hitachi of any abnormal conditions noted during or after programming or in screening of program data after high-temperature baking.

Section 7 RAM

7.1 Overview

The H8/3862, H8/3863, H8/3822, and H8/3823 have 1 kbyte of high-speed static RAM on-chip, and the H8/3864, H8/3865, H8/3866, H8/3867, H8/3824, H8/3825, H8/3826, and H8/3827 have 2 kbytes. The RAM is connected to the CPU by a 16-bit data bus, allowing high-speed 2-state access for both byte data and word data.

7.1.1 Block Diagram

Figure 7.1 shows a block diagram of the on-chip RAM.

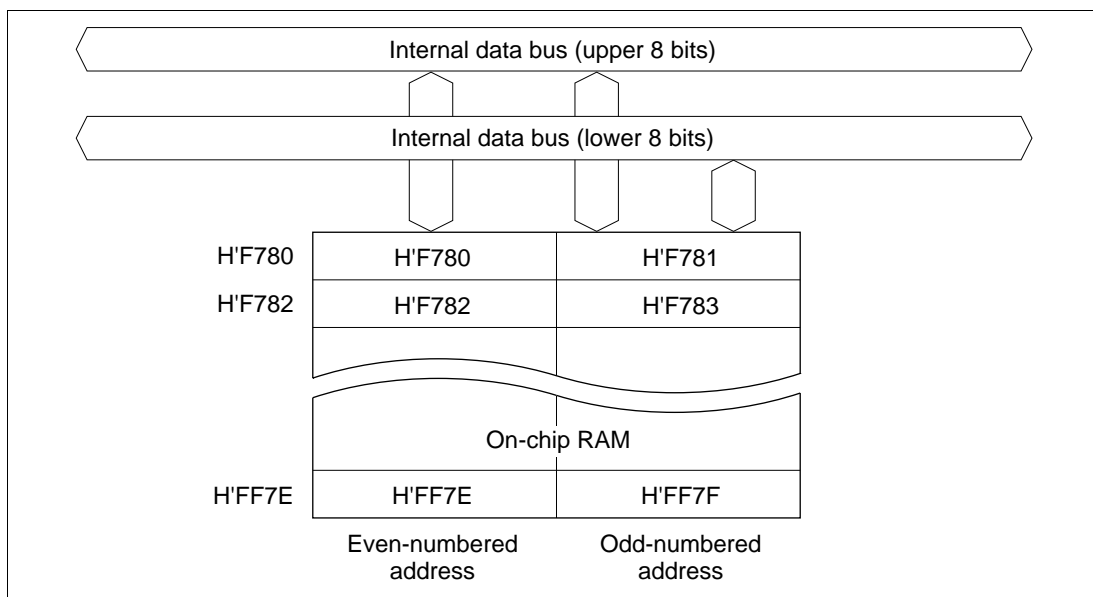

Figure 7.1 RAM Block Diagram (H8/3864 and H8/3824)

Section 8 I/O Ports

8.1 Overview

The H8/3864 Series is provided with six 8-bit I/O ports, one 4-bit I/O port, one 3-bit I/O port, one 8-bit input-only port, and one 1-bit input-only port. Table 8.1 indicates the functions of each port.

Each port has of a port control register (PCR) that controls input and output, and a port data register (PDR) for storing output data. Input or output can be assigned to individual bits. See 2.9.2, Notes on Bit Manipulation, for information on executing bit-manipulation instructions to write data in PCR or PDR.

Ports 5, 6, 7, 8, and A are also used as liquid crystal display segment and common pins, selectable in 8-bit units.

Block diagrams of each port are given in Appendix C, I/O Port Block Diagrams.

Table 8.1 Port Functions

| Port | Description | Pins | Other Functions | Function Switching Registers |
|--------|--|--|---|------------------------------|
| Port 1 | <ul style="list-style-type: none"> 8-bit I/O port MOS input pull-up option | P1 ₇ to P1 ₅ / IRQ ₃ to IRQ ₁ / TMIF, TMIC | External interrupts 3 to 1 Timer event interrupts TMIF, TMIC | PMR1 TCRF, TMC |
| | | P1 ₄ /IRQ ₄ /ADTRG | External interrupt 4 and A/D converter external trigger | PMR1, AMR |
| | | P1 ₃ /TMIG | Timer G input capture input | PMR1 |
| | | P1 ₂ , P1 ₁ / TMOFH, TMOFL | Timer F output compare output | PMR1 |
| | | P1 ₀ /TMOW | Timer A clock output | PMR1 |
| Port 3 | <ul style="list-style-type: none"> 8-bit I/O port MOS input pull-up option Large-current port | P3 ₇ /AEVL P3 ₆ /AEVH P3 ₅ /TXD ₃₁ P3 ₄ /RXD ₃₁ P3 ₃ /SCK ₃₁ | SCI3-1 data output (TXD ₃₁), data input (RXD ₃₁), clock input/output (SCK ₃₁), and asynchronous counter event inputs AEVL, AEVH | PMR3 SCR31 SMR31 |
| | | P3 ₂ /RESO P3 ₁ /UD P3 ₀ /PWM | Reset output, timer C count-up/down select input, and 14-bit PWM output | PMR3 |

Table 8.1 Port Functions (cont)

| Port | Description | Pins | Other Functions | Function Switching Registers |
|--------|----------------------------|---|--|------------------------------|
| Port 4 | • 1-bit input port | P4 ₃ / $\overline{\text{IRQ}}_0$ | External interrupt 0 | PMR3 |
| | • 3-bit I/O port | P4 ₂ /TXD ₃₂ P4 ₁ /RXD ₃₂ P4 ₀ /SCK ₃₂ | SCI3-2 data output (TXD ₃₂), data input (RXD ₃₂), clock input/output (SCK ₃₂) | SCR32 SMR32 |
| Port 5 | • 8-bit I/O port | P5 ₇ to P5 ₀ / $\overline{\text{WKP}}_7$ to $\overline{\text{WKP}}_0$ / SEG ₈ to SEG ₁ | Wakeup input ($\overline{\text{WKP}}_7$ to $\overline{\text{WKP}}_0$), segment output (SEG ₈ to SEG ₁) | PMR5 LPCR |
| | • MOS input pull-up option | | | |
| Port 6 | • 8-bit I/O port | P6 ₇ to P6 ₀ / SEG ₁₆ to SEG ₉ | Segment output (SEG ₁₆ to SEG ₉) | LPCR |
| | • MOS input pull-up option | | | |
| Port 7 | • 8-bit I/O port | P7 ₇ to P7 ₀ / SEG ₂₄ to SEG ₁₇ | Segment output (SEG ₂₄ to SEG ₁₇) | LPCR |
| Port 8 | • 8-bit I/O port | P8 ₇ /SEG ₃₂ /CL ₁ P8 ₆ /SEG ₃₁ /CL ₂ P8 ₅ /SEG ₃₀ /DO P8 ₄ /SEG ₂₉ /M P8 ₃ to P8 ₀ / SEG ₂₈ to SEG ₂₅ | Segment output (SEG ₃₂ to SEG ₂₅) Segment external expansion latch clock (CL ₁), shift clock (CL ₂), display data (DO), alternation signal (M) | LPCR |
| Port A | 4-bit I/O port | PA ₃ to PA ₀ / COM ₄ to COM ₁ | Common output (COM ₄ to COM ₁) | LPCR |
| Port B | 8-bit input port | PB ₇ to PB ₀ / AN ₇ to AN ₀ | A/D converter analog input | AMR |

8.2 Port 1

8.2.1 Overview

Port 1 is a 8-bit I/O port. Figure 8.1 shows its pin configuration.

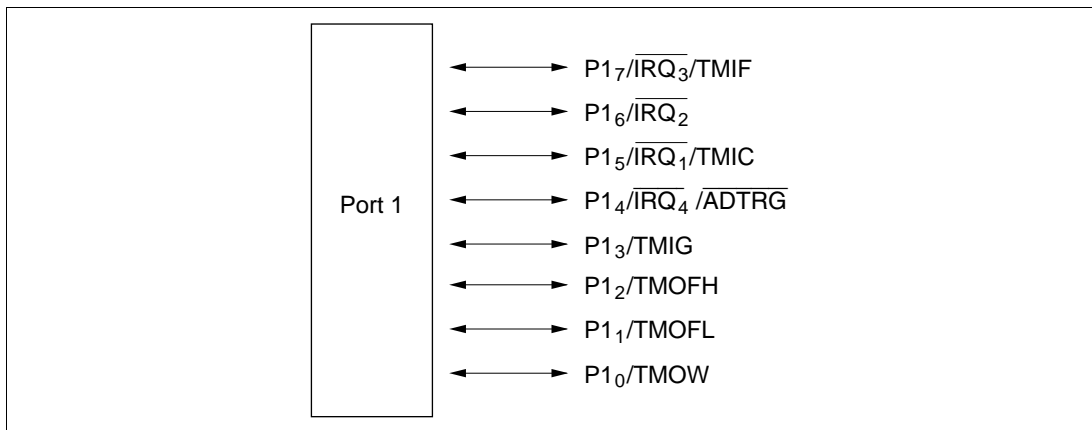

Figure 8.1 Port 1 Pin Configuration

8.2.2 Register Configuration and Description

Table 8.2 shows the port 1 register configuration.

Table 8.2 Port 1 Registers

| Name | Abbrev. | R/W | Initial Value | Address |
|---------------------------------|---------|-----|---------------|---------|
| Port data register 1 | PDR1 | R/W | H'00 | H'FFD4 |
| Port control register 1 | PCR1 | W | H'00 | H'FFE4 |
| Port pull-up control register 1 | PUCR1 | R/W | H'00 | H'FFE0 |
| Port mode register 1 | PMR1 | R/W | H'00 | H'FFC8 |

1. Port data register 1 (PDR1)

| Bit | 7 | 6 | 5 | 4 | 3 | 2 | 1 | 0 |
|---------------|-----------------|-----------------|-----------------|-----------------|-----------------|-----------------|-----------------|-----------------|
| | P1 ₇ | P1 ₆ | P1 ₅ | P1 ₄ | P1 ₃ | P1 ₂ | P1 ₁ | P1 ₀ |
| Initial value | 0 | 0 | 0 | 0 | 0 | 0 | 0 | 0 |
| Read/Write | R/W | R/W | R/W | R/W | R/W | R/W | R/W | R/W |

PDR1 is an 8-bit register that stores data for port 1 pins P1₇ to P1₀. If port 1 is read while PCR1 bits are set to 1, the values stored in PDR1 are read, regardless of the actual pin states. If port 1 is read while PCR1 bits are cleared to 0, the pin states are read.

Upon reset, PDR1 is initialized to H'00.

2. Port control register 1 (PCR1)

| Bit | 7 | 6 | 5 | 4 | 3 | 2 | 1 | 0 |
|---------------|-------------------|-------------------|-------------------|-------------------|-------------------|-------------------|-------------------|-------------------|
| | PCR1 ₇ | PCR1 ₆ | PCR1 ₅ | PCR1 ₄ | PCR1 ₃ | PCR1 ₂ | PCR1 ₁ | PCR1 ₀ |
| Initial value | 0 | 0 | 0 | 0 | 0 | 0 | 0 | 0 |
| Read/Write | W | W | W | W | W | W | W | W |

PCR1 is an 8-bit register for controlling whether each of the port 1 pins P1₇ to P1₀ functions as an input pin or output pin. Setting a PCR1 bit to 1 makes the corresponding pin an output pin, while clearing the bit to 0 makes the pin an input pin. The settings in PCR1 and in PDR1 are valid only when the corresponding pin is designated in PMR1 as a general I/O pin.

Upon reset, PCR1 is initialized to H'00.

PCR1 is a write-only register, which is always read as all 1s.

3. Port pull-up control register 1 (PUCR1)

| | | | | | | | | |
|---------------|--------------------|--------------------|--------------------|--------------------|--------------------|--------------------|--------------------|--------------------|
| Bit | 7 | 6 | 5 | 4 | 3 | 2 | 1 | 0 |
| | PUCR1 ₇ | PUCR1 ₆ | PUCR1 ₅ | PUCR1 ₄ | PUCR1 ₃ | PUCR1 ₂ | PUCR1 ₁ | PUCR1 ₀ |
| Initial value | 0 | 0 | 0 | 0 | 0 | 0 | 0 | 0 |
| Read/Write | R/W | R/W | R/W | R/W | R/W | R/W | R/W | R/W |

PUCR1 controls whether the MOS pull-up of each of the port 1 pins P1₇ to P1₀ is on or off. When a PCR1 bit is cleared to 0, setting the corresponding PUCR1 bit to 1 turns on the MOS pull-up for the corresponding pin, while clearing the bit to 0 turns off the MOS pull-up.

Upon reset, PUCR1 is initialized to H'00.

4. Port mode register 1 (PMR1)

| | | | | | | | | |
|---------------|------|------|------|------|------|-------|-------|------|
| Bit | 7 | 6 | 5 | 4 | 3 | 2 | 1 | 0 |
| | IRQ3 | IRQ2 | IRQ1 | IRQ4 | TMIG | TMOFH | TMOFL | TMOW |
| Initial value | 0 | 0 | 0 | 0 | 0 | 0 | 0 | 0 |
| Read/Write | R/W | R/W | R/W | R/W | R/W | R/W | R/W | R/W |

PMR1 is an 8-bit read/write register, controlling the selection of pin functions for port 1 pins.

Upon reset, PMR1 is initialized to H'00.

Bit 7: P1₇/ $\overline{\text{IRQ}}_3$ /TMIF pin function switch (IRQ3)

This bit selects whether pin P1₇/ $\overline{\text{IRQ}}_3$ /TMIF is used as P1₇ or as $\overline{\text{IRQ}}_3$ /TMIF.

Bit 7

| IRQ3 | Description |
|------|---|
| 0 | Functions as P1 ₇ I/O pin (initial value) |
| 1 | Functions as $\overline{\text{IRQ}}_3$ /TMIF input pin |

Note: Rising or falling edge sensing can be designated for IRQ₃, TMIF. For details on TMIF settings, see 3. Timer Control Register F (TCRF) in 9.4.2.

Bit 6: P1₆/IRQ₂ pin function switch (IRQ2)

This bit selects whether pin P1₆/IRQ₂ is used as P1₆ or as IRQ₂.

Bit 6

| IRQ2 | Description | |
|------|---|-----------------|
| 0 | Functions as P1 ₆ I/O pin | (initial value) |
| 1 | Functions as IRQ ₂ input pin | |

Note: Rising or falling edge sensing can be designated for IRQ₂.

Bit 5: P1₅/IRQ₁/TMIC pin function switch (IRQ1)

This bit selects whether pin P1₅/IRQ₁/TMIC is used as P1₅ or as IRQ₁/TMIC.

Bit 5

| IRQ1 | Description | |
|------|---|-----------------|
| 0 | Functions as P1 ₅ I/O pin | (initial value) |
| 1 | Functions as IRQ ₁ /TMIC input pin | |

Note: Rising or falling edge sensing can be designated for IRQ₁/TMIC.

For details of TMIC pin setting, see 1. Timer mode register C (TMC) in 9.3.2.

Bit 4: P1₄/IRQ₄/ADTRG pin function switch (IRQ4)

This bit selects whether pin P1₄/IRQ₄/ADTRG is used as P1₄ or as IRQ₄/ADTRG.

Bit 4

| IRQ4 | Description | |
|------|--|-----------------|
| 0 | Functions as P1 ₄ I/O pin | (initial value) |
| 1 | Functions as IRQ ₄ /ADTRG input pin | |

Note: For details of ADTRG pin setting, see 12.3.2, Start of A/D Conversion by External Trigger.

Bit 3: P1₃/TMIG pin function switch (TMIG)

This bit selects whether pin P1₃/TMIG is used as P1₃ or as TMIG.

Bit 3

| TMIG | Description | |
|------|--------------------------------------|-----------------|
| 0 | Functions as P1 ₃ I/O pin | (initial value) |
| 1 | Functions as TMIG input pin | |

Bit 2: P1₂/TMOFH pin function switch (TMOFH)

This bit selects whether pin P1₂/TMOFH is used as P1₂ or as TMOFH.

Bit 2

| TMOFH | Description | |
|--------------|--------------------------------------|-----------------|
| 0 | Functions as P1 ₂ I/O pin | (initial value) |
| 1 | Functions as TMOFH output pin | |

Bit 1: P1₁/TMOFL pin function switch (TMOFL)

This bit selects whether pin P1₁/TMOFL is used as P1₁ or as TMOFL.

Bit 1

| TMOFL | Description | |
|--------------|--------------------------------------|-----------------|
| 0 | Functions as P1 ₁ I/O pin | (initial value) |
| 1 | Functions as TMOFL output pin | |

Bit 0: P1₀/TMOW pin function switch (TMOW)

This bit selects whether pin P1₀/TMOW is used as P1₀ or as TMOW.

Bit 0

| TMOW | Description | |
|-------------|--------------------------------------|-----------------|
| 0 | Functions as P1 ₀ I/O pin | (initial value) |
| 1 | Functions as TMOW output pin | |

8.2.3 Pin Functions

Table 8.3 shows the port 1 pin functions.

Table 8.3 Port 1 Pin Functions

Pin Pin Functions and Selection Method

P1₇/IRQ₃/TMIF The pin function depends on bit IRQ3 in PMR1, bits CKSL2 to CKSL0 in TCRF, and bit PCR1₇ in PCR1.

| | | | | |
|-------------------|---------------------------|----------------------------|----------------------------|----------------------------------|
| IRQ ₃ | 0 | | 1 | |
| PCR1 ₇ | 0 | 1 | * | |
| CKSL2 to CKSL0 | * | | Not 0** | 0** |
| Pin function | P1 ₇ input pin | P1 ₇ output pin | IRQ ₃ input pin | IRQ ₃ /TMIF input pin |

Note: When this pin is used as the TMIF input pin, clear bit IEN3 to 0 in IENR1 to disable the IRQ₃ interrupt.

P1₆/IRQ₂ The pin function depends on bits IRQ2 in PMR1 and bit PCR1₆ in PCR1.

| | | | | |
|-------------------|---------------------------|----------------------------|----------------------------|--|
| IRQ2 | 0 | | 1 | |
| PCR1 ₆ | 0 | 1 | * | |
| Pin function | P1 ₆ input pin | P1 ₆ output pin | IRQ ₂ input pin | |

P1₅/IRQ₁/TMIC The pin function depends on bit IRQ1 in PMR1, bits TMC2 to TMC0 in TMC, and bit PCR1₅ in PCR1.

| | | | | |
|-------------------|---------------------------|----------------------------|----------------------------|----------------------------------|
| IRQ1 | 0 | | 1 | |
| PCR1 ₅ | 0 | 1 | * | |
| TMC2 to TMC0 | * | | Not 111 | 111 |
| Pin function | P1 ₅ input pin | P1 ₅ output pin | IRQ ₁ input pin | IRQ ₁ /TMIC input pin |

Note: When this pin is used as the TMIC input pin, clear bit IEN1 to 0 in IENR1 to disable the IRQ₁ interrupt.

P1₄/IRQ₄/ADTRG The pin function depends on bit IRQ4 in PMR1, bit TRGE in AMR, and bit PCR1₄ in PCR1.

| | | | | |
|-------------------|---------------------------|----------------------------|----------------------------|-----------------------------------|
| IRQ4 | 0 | | 1 | |
| PCR1 ₄ | 0 | 1 | * | |
| TRGE | * | | 0 | 1 |
| Pin function | P1 ₄ input pin | P1 ₄ output pin | IRQ ₄ input pin | IRQ ₄ /ADTRG input pin |

Note: When this pin is used as the ADTRG input pin, clear bit IEN4 to 0 in IENR1 to disable the IRQ₄ interrupt.

Table 8.3 Port 1 Pin Functions (cont)**Pin Pin Functions and Selection Method**

| | | | | |
|------------------------|--|---------------------------|----------------------------|------------------|
| P1 ₃ /TMIG | The pin function depends on bit TMIG in PMR1 and bit PCR1 ₃ in PCR1. | | | |
| | TMIG | 0 | | 1 |
| | PCR1 ₃ | 0 | 1 | * |
| | Pin function | P1 ₃ input pin | P1 ₃ output pin | TMIG input pin |
| P1 ₂ /TMOFH | The pin function depends on bit TMOFH in PMR1 and bit PCR1 ₂ in PCR1. | | | |
| | TMOFH | 0 | | 1 |
| | PCR1 ₂ | 0 | 1 | * |
| | Pin function | P1 ₂ input pin | P1 ₂ output pin | TMOFH output pin |
| P1 ₁ /TMOFL | The pin function depends on bit TMOFL in PMR1 and bit PCR1 ₁ in PCR1. | | | |
| | TMOFL | 0 | | 1 |
| | PCR1 ₁ | 0 | 1 | * |
| | Pin function | P1 ₁ input pin | P1 ₁ output pin | TMOFL output pin |
| P1 ₀ /TMOW | The pin function depends on bit TMOW in PMR1 and bit PCR1 ₀ in PCR1. | | | |
| | TMOW | 0 | | 1 |
| | PCR1 ₀ | 0 | 1 | * |
| | Pin function | P1 ₀ input pin | P1 ₀ output pin | TMOW output pin |

*: Don't care

8.2.4 Pin States

Table 8.4 shows the port 1 pin states in each operating mode.

Table 8.4 Port 1 Pin States

| Pins | Reset | Sleep | Subsleep | Standby | Watch | Subactive | Active |
|--|----------------|----------|----------|------------|----------|------------|------------|
| P1 ₇ /IRQ ₃ /TMIF | High-impedance | Retains | Retains | High- | Retains | Functional | Functional |
| P1 ₆ /IRQ ₂ | | previous | previous | impedance* | previous | | |
| P1 ₅ /IRQ ₁ /TMIC | | state | state | | state | | |
| P1 ₄ /IRQ ₄ /ADTRG | | | | | | | |
| P1 ₃ /TMIG | | | | | | | |
| P1 ₂ /TMOFH | | | | | | | |
| P1 ₁ /TMOFL | | | | | | | |
| P1 ₀ /TMOW | | | | | | | |

Note: * A high-level signal is output when the MOS pull-up is in the on state.

8.2.5 MOS Input Pull-Up

Port 1 has a built-in MOS input pull-up function that can be controlled by software. When a PCR1 bit is cleared to 0, setting the corresponding PUCR1 bit to 1 turns on the MOS input pull-up for that pin. The MOS input pull-up function is in the off state after a reset.

| | | | |
|--------------------|-----|----|-----|
| PCR1 _n | 0 | 0 | 1 |
| PUCR1 _n | 0 | 1 | * |
| MOS input pull-up | Off | On | Off |

(n = 7 to 0)

*: Don't care

8.3 Port 3

8.3.1 Overview

Port 3 is a 8-bit I/O port, configured as shown in figure 8.2.

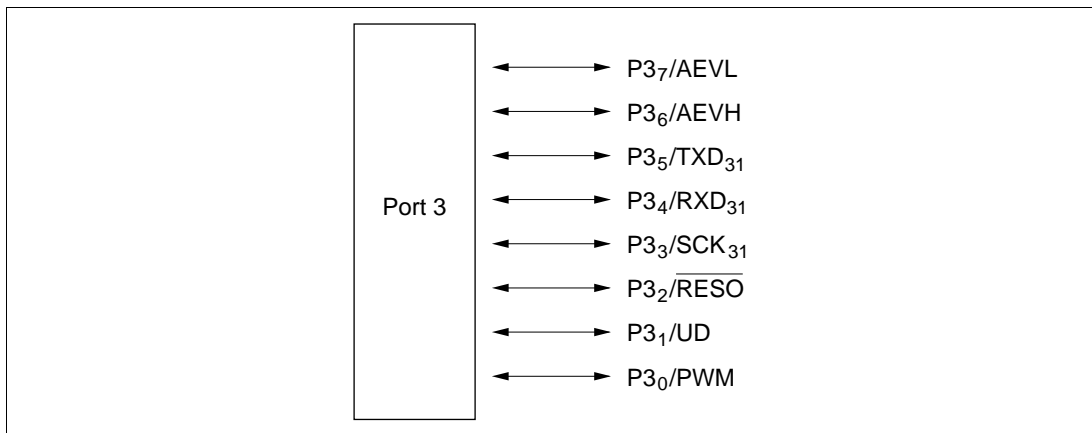

Figure 8.2 Port 3 Pin Configuration

8.3.2 Register Configuration and Description

Table 8.5 shows the port 3 register configuration.

Table 8.5 Port 3 Registers

| Name | Abbrev. | R/W | Initial Value | Address |
|---------------------------------|---------|-----|---------------|---------|
| Port data register 3 | PDR3 | R/W | H'00 | H'FFD6 |
| Port control register 3 | PCR3 | W | H'00 | H'FFE6 |
| Port pull-up control register 3 | PUCR3 | R/W | H'00 | H'FFE1 |
| Port mode register 3 | PMR3 | R/W | H'04 | H'FFCA |

1. Port data register 3 (PDR3)

| Bit | 7 | 6 | 5 | 4 | 3 | 2 | 1 | 0 |
|---------------|-----------------|-----------------|-----------------|-----------------|-----------------|-----------------|-----------------|-----------------|
| | P3 ₇ | P3 ₆ | P3 ₅ | P3 ₄ | P3 ₃ | P3 ₂ | P3 ₁ | P3 ₀ |
| Initial value | 0 | 0 | 0 | 0 | 0 | 0 | 0 | 0 |
| Read/Write | R/W | R/W | R/W | R/W | R/W | R/W | R/W | R/W |

PDR3 is an 8-bit register that stores data for port 3 pins P3₇ to P3₀. If port 3 is read while PCR3 bits are set to 1, the values stored in PDR3 are read, regardless of the actual pin states. If port 3 is read while PCR3 bits are cleared to 0, the pin states are read.

Upon reset, PDR3 is initialized to H'00.

2. Port control register 3 (PCR3)

| Bit | 7 | 6 | 5 | 4 | 3 | 2 | 1 | 0 |
|---------------|-------------------|-------------------|-------------------|-------------------|-------------------|-------------------|-------------------|-------------------|
| | PCR3 ₇ | PCR3 ₆ | PCR3 ₅ | PCR3 ₄ | PCR3 ₃ | PCR3 ₂ | PCR3 ₁ | PCR3 ₀ |
| Initial value | 0 | 0 | 0 | 0 | 0 | 0 | 0 | 0 |
| Read/Write | W | W | W | W | W | W | W | W |

PCR3 is an 8-bit register for controlling whether each of the port 3 pins P3₇ to P3₀ functions as an input pin or output pin. Setting a PCR3 bit to 1 makes the corresponding pin an output pin, while clearing the bit to 0 makes the pin an input pin. The settings in PCR3 and in PDR3 are valid only when the corresponding pin is designated in PMR3 as a general I/O pin.

Upon reset, PCR3 is initialized to H'00.

PCR3 is a write-only register, which is always read as all 1s.

3. Port pull-up control register 3 (PUCR3)

| Bit | 7 | 6 | 5 | 4 | 3 | 2 | 1 | 0 |
|---------------|--------------------|--------------------|--------------------|--------------------|--------------------|--------------------|--------------------|--------------------|
| | PUCR3 ₇ | PUCR3 ₆ | PUCR3 ₅ | PUCR3 ₄ | PUCR3 ₃ | PUCR3 ₂ | PUCR3 ₁ | PUCR3 ₀ |
| Initial value | 0 | 0 | 0 | 0 | 0 | 0 | 0 | 0 |
| Read/Write | R/W | R/W | R/W | R/W | R/W | R/W | R/W | R/W |

PUCR3 controls whether the MOS pull-up of each of the port 3 pins P3₇ to P3₀ is on or off. When a PCR3 bit is cleared to 0, setting the corresponding PUCR3 bit to 1 turns on the MOS pull-up for the corresponding pin, while clearing the bit to 0 turns off the MOS pull-up.

Upon reset, PUCR3 is initialized to H'00.

4. Port mode register 3 (PMR3)

| | | | | | | | | |
|---------------|------|------|-------|-----|------|------|-----|-----|
| Bit | 7 | 6 | 5 | 4 | 3 | 2 | 1 | 0 |
| | AEVL | AEVH | WDCKS | NCS | IRQ0 | RESO | UD | PWM |
| Initial value | 0 | 0 | 0 | 0 | 0 | 1 | 0 | 0 |
| Read/Write | R/W | R/W | R/W | R/W | R/W | R/W | R/W | R/W |

PMR3 is an 8-bit read/write register, controlling the selection of pin functions for port 3 pins.

Upon reset, PMR3 is initialized to H'04.

Bit 7: P3₇/AEVL pin function switch (AEVL)

This bit selects whether pin P3₇/AEVL is used as P3₇ or as AEVL.

Bit 7

| AEVL | Description |
|------|--|
| 0 | Functions as P3 ₇ I/O pin (initial value) |
| 1 | Functions as AEVL input pin |

Bit 6: P3₆/AEVH pin function switch (AEVH)

This bit selects whether pin P3₆/AEVH is used as P3₆ or as AEVH.

Bit 6

| AEVH | Description |
|------|--|
| 0 | Functions as P3 ₆ I/O pin (initial value) |
| 1 | Functions as AEVH input pin |

Bit 5: Watchdog timer source clock select (WDCKS)

This bit selects the watchdog timer source clock.

Bit 5

| WDCKS | Description |
|-------|---------------------------------|
| 0 | ø/8192 selected (initial value) |
| 1 | øw/32 selected |

Bit 4: TMIG noise canceler select (NCS)

This bit controls the noise canceler for the input capture input signal (TMIG).

Bit 4

| NCS | Description | |
|------------|--------------------------------------|-----------------|
| 0 | Noise cancellation function not used | (initial value) |
| 1 | Noise cancellation function used | |

Bit 3: P4₃/ $\overline{\text{IRQ}}_0$ pin function switch (IRQ0)

This bit selects whether pin P4₃/ $\overline{\text{IRQ}}_0$ is used as P4₃ or as $\overline{\text{IRQ}}_0$.

Bit 3

| IRQ0 | Description | |
|-------------|--|-----------------|
| 0 | Functions as P4 ₃ input pin | (initial value) |
| 1 | Functions as $\overline{\text{IRQ}}_0$ input pin | |

Bit 2: P3₂/ $\overline{\text{RESO}}$ pin function switch (RESO)

This bit selects whether pin P3₂/ $\overline{\text{RESO}}$ is used as P3₂ or as $\overline{\text{RESO}}$.

Bit 2

| RESO | Description | |
|-------------|--|-----------------|
| 0 | Functions as P3 ₂ I/O pin | |
| 1 | Functions as $\overline{\text{RESO}}$ output pin | (initial value) |

Bit 1: P3₁/UD pin function switch (SI1)

This bit selects whether pin P3₁/UD is used as P3₁ or as UD.

Bit 1

| UD | Description | |
|-----------|--------------------------------------|-----------------|
| 0 | Functions as P3 ₁ I/O pin | (initial value) |
| 1 | Functions as UD input pin | |

Bit 0: P3₀/PWM pin function switch (PWM)

This bit selects whether pin P3₀/PWM is used as P3₀ or as PWM.

Bit 0**PWM****Description**

| Bit 0 PWM | Description |
|-----------|--|
| 0 | Functions as P3 ₀ I/O pin (initial value) |
| 1 | Functions as PWM output pin |

8.3.3 Pin Functions

Table 8.9 shows the port 3 pin functions.

Table 8.9 Port 3 Pin Functions**Pin Pin Functions and Selection Method**

| | | | | |
|------------------------------------|---|---------------------------|----------------------------|------------------------------|
| P3 ₇ /AEVL | The pin function depends on bit SO1 in PMR3 and bit PCR3 ₂ in PCR3. | | | |
| | AEVL | 0 | | 1 |
| | PCR3 ₇ | 0 | 1 | * |
| | Pin function | P3 ₇ input pin | P3 ₇ output pin | AEVL input pin |
| P3 ₆ /AEVH | The pin function depends on bit AEVH in PMR3 and bit PCR3 ₆ in PCR3. | | | |
| | AEVH | 0 | | 1 |
| | PCR3 ₆ | 0 | 1 | * |
| | Pin function | P3 ₆ input pin | P3 ₆ output pin | AEVH input pin |
| P3 ₅ /TXD ₃₁ | The pin function depends on bit TE in SCR3-1, bit SPC31 in SPCR, and bit PCR3 ₅ in PCR3. | | | |
| | SPC31 | 0 | | 1 |
| | TE | 0 | | 1 |
| | PCR3 ₅ | 0 | 1 | * |
| | Pin function | P3 ₅ input pin | P3 ₅ output pin | TXD ₃₁ output pin |

*: Don't care

Table 8.9 Port 3 Pin Functions (cont)**Pin Pin Functions and Selection Method**

P3₄/RXD₃₁ The pin function depends on bit RE in SCR3-1 and bit PCR3₄ in PCR3.

| | | | |
|-------------------|---------------------------|----------------------------|-----------------------------|
| RE | 0 | | 1 |
| PCR3 ₄ | 0 | 1 | * |
| Pin function | P3 ₄ input pin | P3 ₄ output pin | RXD ₃₁ input pin |

P3₃/SCK₃₁ The pin function depends on bits CEK1, CEK0, and SMR31 in SCR3-1 and bit PCR3₃ in PCR3.

| | | | | |
|-------------------|---------------------------|----------------------------|------------------------------|-----------------------------|
| CEK1 | 0 | | | 1 |
| CEK0 | 0 | | 1 | * |
| COM3 ₁ | 0 | | 1 | * |
| PCR3 ₃ | 0 | 1 | * | * |
| Pin function | P3 ₃ input pin | P3 ₃ output pin | SCK ₃₁ output pin | SCK ₃₁ input pin |

P3₂/RESO The pin function depends on bit RESO in PMR3 and bit PCR3₂ in PCR3.

| | | | |
|-------------------|---------------------------|----------------------------|-----------------|
| RESO | 0 | | 1 |
| PCR3 ₂ | 0 | 1 | * |
| Pin function | P3 ₂ input pin | P3 ₂ output pin | RESO output pin |

P3₁/UD The pin function depends on bit UD in PMR3 and bit PCR3₁ in PCR3.

| | | | |
|-------------------|---------------------------|----------------------------|--------------|
| UD | 0 | | 1 |
| PCR3 ₁ | 0 | 1 | * |
| Pin function | P3 ₁ input pin | P3 ₁ output pin | UD input pin |

P3₀/PWM The pin function depends on bit PWM in PMR3 and bit PCR3₀ in PCR3.

| | | | |
|-------------------|---------------------------|----------------------------|----------------|
| PWM | 0 | | 1 |
| PCR3 ₀ | 0 | 1 | * |
| Pin function | P3 ₀ input pin | P3 ₀ output pin | PWM output pin |

*: Don't care

8.3.4 Pin States

Table 8.10 shows the port 3 pin states in each operating mode.

Table 8.10 Port 3 Pin States

| Pins | Reset | Sleep | Subsleep | Standby | Watch | Subactive | Active |
|--|----------------|------------------------|------------------------|-----------------|------------------------|------------|------------|
| P3 ₇ /AEVL P3 ₆ /AEVH P3 ₅ /TXD ₃₁ P3 ₄ /RXD ₃₁ P3 ₃ /SCK ₃₁ | High-impedance | Retains previous state | Retains previous state | High-impedance* | Retains previous state | Functional | Functional |
| P3 ₂ /RESO | RESO output | | | | | | |
| P3 ₁ /UD P3 ₀ /PWM | High-impedance | | | | | | |

Note: * A high-level signal is output when the MOS pull-up is in the on state.

8.3.5 MOS Input Pull-Up

Port 3 has a built-in MOS input pull-up function that can be controlled by software. When a PCR3 bit is cleared to 0, setting the corresponding PUCR3 bit to 1 turns on the MOS pull-up for that pin. The MOS pull-up function is in the off state after a reset.

| | | | |
|--------------------|-----|----|-----|
| PCR3 _n | 0 | 0 | 1 |
| PUCR3 _n | 0 | 1 | * |
| MOS input pull-up | Off | On | Off |

(n = 7 to 0)

*: Don't care

8.4 Port 4

8.4.1 Overview

Port 4 is a 3-bit I/O port and 1-bit input port, configured as shown in figure 8.3.

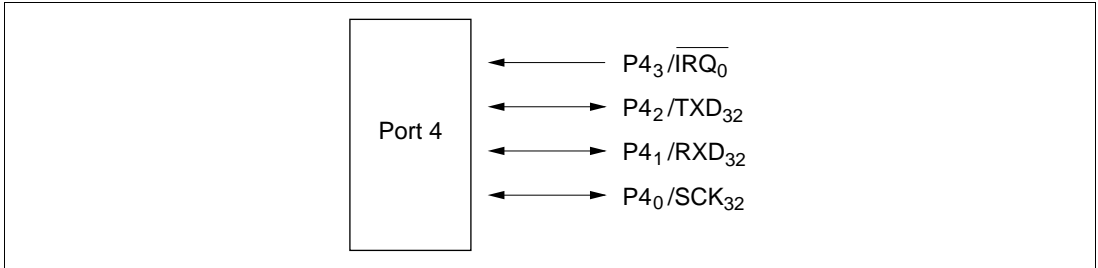

Figure 8.3 Port 4 Pin Configuration

8.4.2 Register Configuration and Description

Table 8.8 shows the port 4 register configuration.

Table 8.8 Port 4 Registers

| Name | Abbrev. | R/W | Initial Value | Address |
|-------------------------|---------|-----|---------------|---------|
| Port data register 4 | PDR4 | R/W | H'F8 | H'FFD7 |
| Port control register 4 | PCR4 | W | H'F8 | H'FFE7 |

1. Port data register 4 (PDR4)

| Bit | 7 | 6 | 5 | 4 | 3 | 2 | 1 | 0 |
|---------------|---|---|---|---|-----------------|-----------------|-----------------|-----------------|
| | — | — | — | — | P4 ₃ | P4 ₂ | P4 ₁ | P4 ₀ |
| Initial value | 1 | 1 | 1 | 1 | 1 | 0 | 0 | 0 |
| Read/Write | — | — | — | — | R | R/W | R/W | R/W |

PDR4 is an 8-bit register that stores data for port 4 pins P4₂ to P4₀. If port 4 is read while PCR4 bits are set to 1, the values stored in PDR4 are read, regardless of the actual pin states. If port 4 is read while PCR4 bits are cleared to 0, the pin states are read.

Upon reset, PDR4 is initialized to H'F8.

2. Port control register 4 (PCR4)

| | | | | | | | | |
|---------------|---|---|---|---|---|-------------------|-------------------|-------------------|
| Bit | 7 | 6 | 5 | 4 | 3 | 2 | 1 | 0 |
| | — | — | — | — | — | PCR4 ₂ | PCR4 ₁ | PCR4 ₀ |
| Initial value | 1 | 1 | 1 | 1 | 1 | 0 | 0 | 0 |
| Read/Write | — | — | — | — | — | W | W | W |

PCR4 is an 8-bit register for controlling whether each of port 4 pins P4₂ to P4₀ functions as an input pin or output pin. Setting a PCR4 bit to 1 makes the corresponding pin an output pin, while clearing the bit to 0 makes the pin an input pin. PCR4 and PDR4 settings are valid when the corresponding pins are designated for general-purpose input/output by SCR3-2.

Upon reset, PCR4 is initialized to H'F8.

PCR4 is a write-only register, which always reads all 1s.

8.4.3 Pin Functions

Table 8.9 shows the port 4 pin functions.

Table 8.9 Port 4 Pin Functions

| Pin | Pin Functions and Selection Method | | |
|------------------------------------|---|---------------------------|----------------------------|
| P4 ₃ /IRQ ₀ | The pin function depends on bit IRQ0 in PMR3. | | |
| | IRQ0 | 0 | 1 |
| | Pin function | P4 ₃ input pin | IRQ ₀ input pin |
| P4 ₂ /TXD ₃₂ | The pin function depends on bit TE in SCR3-2, bit SPC32 in SPCR, and bit PCR4 ₂ in PCR4. | | |
| | SPC32 | 0 | 1 |
| | TE | 0 | 1 |
| | PCR4 ₂ | 0 | 1 |
| | Pin function | P4 ₂ input pin | P4 ₂ output pin |
| P4 ₁ /RXD ₃₂ | The pin function depends on bit RE in SCR3-2 and bit PCR4 ₁ in PCR4. | | |
| | RE ₃₂ | 0 | 1 |
| | PCR4 ₁ | 0 | 1 |
| | Pin function | P4 ₁ input pin | P4 ₁ output pin |

*: Don't care

Table 8.9 Port 4 Pin Functions (cont)**Pin Pin Functions and Selection Method**

P4₀/SCK₃₂ The pin function depends on bit CKE1 and CKE0 in SCR3-2, bit COM32 in SMR32, and bit PCR4₀ in PCR4.

| | | | | |
|-------------------|---------------------------|----------------------------|------------------------------|-----------------------------|
| CKE1 | 0 | | | 1 |
| CKE0 | 0 | | 1 | * |
| COM32 | 0 | | 1 | * |
| PCR4 ₀ | 0 | 1 | * | * |
| Pin function | P4 ₀ input pin | P4 ₀ output pin | SCK ₃₂ output pin | SCK ₃₂ input pin |

8.4.4 Pin States

Table 8.10 shows the port 4 pin states in each operating mode.

Table 8.10 Port 4 Pin States

| Pins | Reset | Sleep | Subsleep | Standby | Watch | Subactive | Active |
|------------------------------------|-----------|----------|----------|-----------|----------|------------|------------|
| P4 ₃ /IRQ ₀ | High- | Retains | Retains | High- | Retains | Functional | Functional |
| P4 ₂ /TXD ₃₂ | impedance | previous | previous | impedance | previous | | |
| P4 ₁ /RXD ₃₂ | | state | state | | state | | |
| P4 ₀ /SCK ₃₂ | | | | | | | |

8.5 Port 5

8.5.1 Overview

Port 5 is an 8-bit I/O port, configured as shown in figure 8.4.

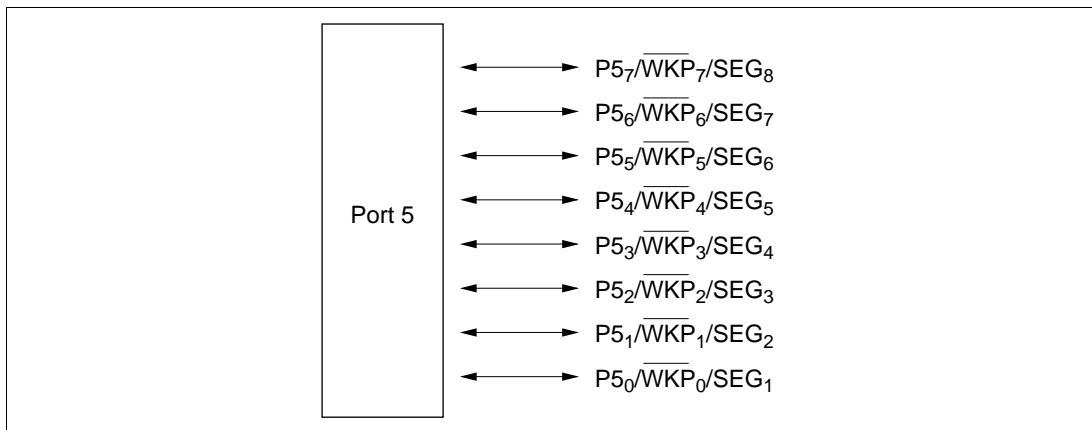

Figure 8.4 Port 5 Pin Configuration

8.5.2 Register Configuration and Description

Table 8.11 shows the port 5 register configuration.

Table 8.11 Port 5 Registers

| Name | Abbrev. | R/W | Initial Value | Address |
|---------------------------------|---------|-----|---------------|---------|
| Port data register 5 | PDR5 | R/W | H'00 | H'FFD8 |
| Port control register 5 | PCR5 | W | H'00 | H'FFE8 |
| Port pull-up control register 5 | PUCR5 | R/W | H'00 | H'FFE2 |
| Port mode register 5 | PMR5 | R/W | H'00 | H'FFCC |

1. Port data register 5 (PDR5)

| Bit | 7 | 6 | 5 | 4 | 3 | 2 | 1 | 0 |
|---------------|-----------------|-----------------|-----------------|-----------------|-----------------|-----------------|-----------------|-----------------|
| | P5 ₇ | P5 ₆ | P5 ₅ | P5 ₄ | P5 ₃ | P5 ₂ | P5 ₁ | P5 ₀ |
| Initial value | 0 | 0 | 0 | 0 | 0 | 0 | 0 | 0 |
| Read/Write | R/W | R/W | R/W | R/W | R/W | R/W | R/W | R/W |

PDR5 is an 8-bit register that stores data for port 5 pins P5₇ to P5₀. If port 5 is read while PCR5 bits are set to 1, the values stored in PDR5 are read, regardless of the actual pin states. If port 5 is read while PCR5 bits are cleared to 0, the pin states are read.

Upon reset, PDR5 is initialized to H'00.

2. Port control register 5 (PCR5)

| Bit | 7 | 6 | 5 | 4 | 3 | 2 | 1 | 0 |
|---------------|-------------------|-------------------|-------------------|-------------------|-------------------|-------------------|-------------------|-------------------|
| | PCR5 ₇ | PCR5 ₆ | PCR5 ₅ | PCR5 ₄ | PCR5 ₃ | PCR5 ₂ | PCR5 ₁ | PCR5 ₀ |
| Initial value | 0 | 0 | 0 | 0 | 0 | 0 | 0 | 0 |
| Read/Write | W | W | W | W | W | W | W | W |

PCR5 is an 8-bit register for controlling whether each of the port 5 pins P5₇ to P5₀ functions as an input pin or output pin. Setting a PCR5 bit to 1 makes the corresponding pin an output pin, while clearing the bit to 0 makes the pin an input pin. PCR5 and PDR5 settings are valid when the corresponding pins are designated for general-purpose input/output by PMR5 and bits SGS3 to SGS0 in LPCR.

Upon reset, PCR5 is initialized to H'00.

PCR5 is a write-only register, which is always read as all 1s.

3. Port pull-up control register 5 (PUCR5)

| Bit | 7 | 6 | 5 | 4 | 3 | 2 | 1 | 0 |
|---------------|--------------------|--------------------|--------------------|--------------------|--------------------|--------------------|--------------------|--------------------|
| | PUCR5 ₇ | PUCR5 ₆ | PUCR5 ₅ | PUCR5 ₄ | PUCR5 ₃ | PUCR5 ₂ | PUCR5 ₁ | PUCR5 ₀ |
| Initial value | 0 | 0 | 0 | 0 | 0 | 0 | 0 | 0 |
| Read/Write | R/W | R/W | R/W | R/W | R/W | R/W | R/W | R/W |

PUCR5 controls whether the MOS pull-up of each of port 5 pins P5₇ to P5₀ is on or off. When a PCR5 bit is cleared to 0, setting the corresponding PUCR5 bit to 1 turns on the MOS pull-up for the corresponding pin, while clearing the bit to 0 turns off the MOS pull-up.

Upon reset, PUCR5 is initialized to H'00.

4. Port mode register 5 (PMR5)

| | | | | | | | | |
|---------------|------------------|------------------|------------------|------------------|------------------|------------------|------------------|------------------|
| Bit | 7 | 6 | 5 | 4 | 3 | 2 | 1 | 0 |
| | WKP ₇ | WKP ₆ | WKP ₅ | WKP ₄ | WKP ₃ | WKP ₂ | WKP ₁ | WKP ₀ |
| Initial value | 0 | 0 | 0 | 0 | 0 | 0 | 0 | 0 |
| Read/Write | R/W | R/W | R/W | R/W | R/W | R/W | R/W | R/W |

PMR5 is an 8-bit read/write register, controlling the selection of pin functions for port 5 pins.

Upon reset, PMR5 is initialized to H'00.

Bit n: P5_n/ $\overline{\text{WKP}}_n$ /SEG_{n+1} pin function switch (WKP_n)

When pin P5_n/ $\overline{\text{WKP}}_n$ /SEG_{n+1} is not used as SEG_{n+1}, these bits select whether the pin is used as P5_n or $\overline{\text{WKP}}_n$.

Bit n

| WKP _n | Description |
|------------------|--|
| 0 | Functions as P5 _n I/O pin (initial value) |
| 1 | Functions as $\overline{\text{WKP}}_n$ input pin |

(n = 7 to 0)

Note: For use as SEG_{n+1}, see 13.2.1, LCD Port Control Register (LPCR).

8.5.3 Pin Functions

Table 8.12 shows the port 5 pin functions.

Table 8.12 Port 5 Pin Functions

| Pin | Pin Functions and Selection Method | | | |
|---|---|---------------------------|----------------------------|---|
| P5 ₇ / \overline{WKP}_7 / SEG ₈ to P5 ₀ / \overline{WKP}_0 / SEG ₁ | The pin function depends on bit WKP _n in PMR5, bit PCR5 _n in PCR5, and bits SGS3 to SGS0 in LPCR. (n = 7 to 0) | | | |
| | SGS3 to SGS0 | 0*** | | 1*** |
| | WKP _n | 0 | 1 | * |
| | PCR5 _n | 0 | 1 | * |
| | Pin function | P5 _n input pin | P5 _n output pin | \overline{WKP}_n input pin SEG _{n+1} output pin |

*: Don't care

8.5.4 Pin States

Table 8.13 shows the port 5 pin states in each operating mode.

Table 8.13 Port 5 Pin States

| Pins | Reset | Sleep | Subsleep | Standby | Watch | Subactive | Active |
|---|----------------|------------------------|------------------------|-----------------|------------------------|------------|------------|
| P5 ₇ / \overline{WKP}_7 / SEG ₈ to P5 ₀ / \overline{WKP}_0 /SEG ₁ | High-impedance | Retains previous state | Retains previous state | High-impedance* | Retains previous state | Functional | Functional |

Note: * A high-level signal is output when the MOS pull-up is in the on state.

8.5.5 MOS Input Pull-Up

Port 5 has a built-in MOS input pull-up function that can be controlled by software. When a PCR5 bit is cleared to 0, setting the corresponding PUCR5 bit to 1 turns on the MOS pull-up for that pin. The MOS pull-up function is in the off state after a reset.

| | | | |
|--------------------|-----|----|-----|
| PCR5 _n | 0 | 0 | 1 |
| PUCR5 _n | 0 | 1 | * |
| MOS input pull-up | Off | On | Off |

(n = 7 to 0)

*: Don't care

8.6 Port 6

8.6.1 Overview

Port 6 is an 8-bit I/O port. The port 6 pin configuration is shown in figure 8.5.

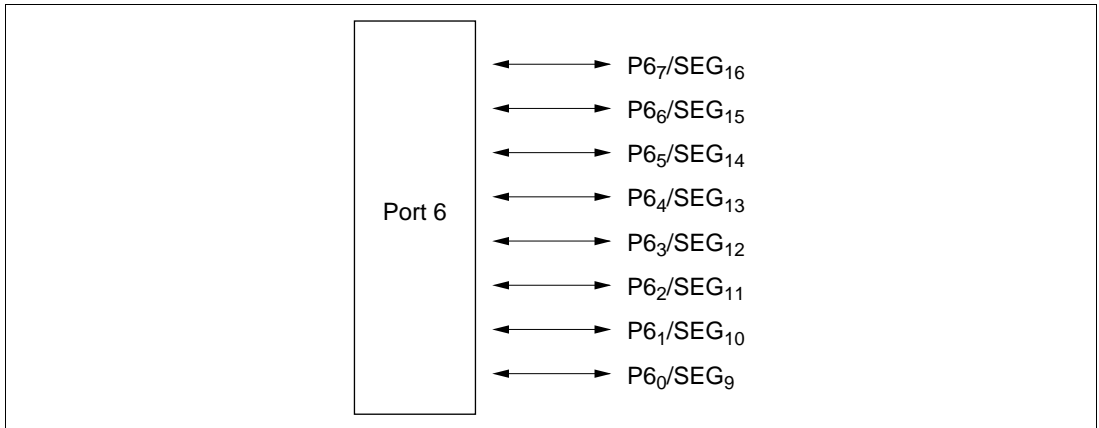

Figure 8.5 Port 6 Pin Configuration

8.6.2 Register Configuration and Description

Table 8.14 shows the port 6 register configuration.

Table 8.14 Port 6 Registers

| Name | Abbrev. | R/W | Initial Value | Address |
|---------------------------------|---------|-----|---------------|---------|
| Port data register 6 | PDR6 | R/W | H'00 | H'FFD9 |
| Port control register 6 | PCR6 | W | H'00 | H'FFE9 |
| Port pull-up control register 6 | PUCR6 | R/W | H'00 | H'FFE3 |

1. Port data register 6 (PDR6)

| Bit | 7 | 6 | 5 | 4 | 3 | 2 | 1 | 0 |
|---------------|-----------------|-----------------|-----------------|-----------------|-----------------|-----------------|-----------------|-----------------|
| | P6 ₇ | P6 ₆ | P6 ₅ | P6 ₄ | P6 ₃ | P6 ₂ | P6 ₁ | P6 ₀ |
| Initial value | 0 | 0 | 0 | 0 | 0 | 0 | 0 | 0 |
| Read/Write | R/W | R/W | R/W | R/W | R/W | R/W | R/W | R/W |

PDR6 is an 8-bit register that stores data for port 6 pins P6₇ to P6₀.

If port 6 is read while PCR6 bits are set to 1, the values stored in PDR6 are read, regardless of the actual pin states. If port 6 is read while PCR6 bits are cleared to 0, the pin states are read.

Upon reset, PDR6 is initialized to H'00.

2. Port control register 6 (PCR6)

| Bit | 7 | 6 | 5 | 4 | 3 | 2 | 1 | 0 |
|---------------|-------------------|-------------------|-------------------|-------------------|-------------------|-------------------|-------------------|-------------------|
| | PCR6 ₇ | PCR6 ₆ | PCR6 ₅ | PCR6 ₄ | PCR6 ₃ | PCR6 ₂ | PCR6 ₁ | PCR6 ₀ |
| Initial value | 0 | 0 | 0 | 0 | 0 | 0 | 0 | 0 |
| Read/Write | W | W | W | W | W | W | W | W |

PCR6 is an 8-bit register for controlling whether each of the port 6 pins P6₇ to P6₀ functions as an input pin or output pin.

Setting a PCR6 bit to 1 makes the corresponding pin (P6₇ to P6₀) an output pin, while clearing the bit to 0 makes the pin an input pin. PCR6 and PDR6 settings are valid when the corresponding pins are designated for general-purpose input/output by bits SGS3 to SGS0 in LPCR.

Upon reset, PCR6 is initialized to H'00.

PCR6 is a write-only register, which always reads all 1s.

3. Port pull-up control register 6 (PUCR6)

| | | | | | | | | |
|---------------|--------------------|--------------------|--------------------|--------------------|--------------------|--------------------|--------------------|--------------------|
| Bit | 7 | 6 | 5 | 4 | 3 | 2 | 1 | 0 |
| | PUCR6 ₇ | PUCR6 ₆ | PUCR6 ₅ | PUCR6 ₄ | PUCR6 ₃ | PUCR6 ₂ | PUCR6 ₁ | PUCR6 ₀ |
| Initial value | 0 | 0 | 0 | 0 | 0 | 0 | 0 | 0 |
| Read/Write | R/W | R/W | R/W | R/W | R/W | R/W | R/W | R/W |

PUCR6 controls whether the MOS pull-up of each of the port 6 pins P6₇ to P6₀ is on or off. When a PCR6 bit is cleared to 0, setting the corresponding PUCR6 bit to 1 turns on the MOS pull-up for the corresponding pin, while clearing the bit to 0 turns off the MOS pull-up.

Upon reset, PUCR6 is initialized to H'00.

8.6.3 Pin Functions

Table 8.15 shows the port 6 pin functions.

Table 8.15 Port 6 Pin Functions

| Pin | Pin Functions and Selection Method | | |
|---|--|---------------------------|-------------------------------|
| P6 ₇ /SEG ₁₆ to P6 ₀ /SEG ₉ | The pin function depends on bit PCR6 _n in PCR6 and bits SGS3 to SGS0 in LPCR. (n = 7 to 0) | | |
| | SEG3 to SEG ₀ | 00**, 010* | 011**, 1*** |
| | PCR6 _n | 0 | 1 |
| | Pin function | P6 _n input pin | P6 _n output pin |
| | | | SEG _{n+9} output pin |

*: Don't care

8.6.4 Pin States

Table 8.16 shows the port 6 pin states in each operating mode.

Table 8.16 Port 6 Pin States

| Pin | Reset | Sleep | Subsleep | Standby | Watch | Subactive | Active |
|---|----------------|------------------------|------------------------|-----------------|------------------------|------------|------------|
| P6 ₇ /SEG ₁₆ to P6 ₀ /SEG ₉ | High-impedance | Retains previous state | Retains previous state | High-impedance* | Retains previous state | Functional | Functional |

Note: * A high-level signal is output when the MOS pull-up is in the on state.

8.6.5 MOS Input Pull-Up

Port 6 has a built-in MOS pull-up function that can be controlled by software. When a PCR6 bit is cleared to 0, setting the corresponding PUCR6 bit to 1 turns on the MOS pull-up for that pin. The MOS pull-up function is in the off state after a reset.

| | | | |
|--------------------|-----|----|-----|
| PCR6 _n | 0 | 0 | 1 |
| PUCR6 _n | 0 | 1 | * |
| MOS input pull-up | Off | On | Off |

(n = 7 to 0)

*: Don't care

8.7 Port 7

8.7.1 Overview

Port 7 is a 8-bit I/O port, configured as shown in figure 8.6.

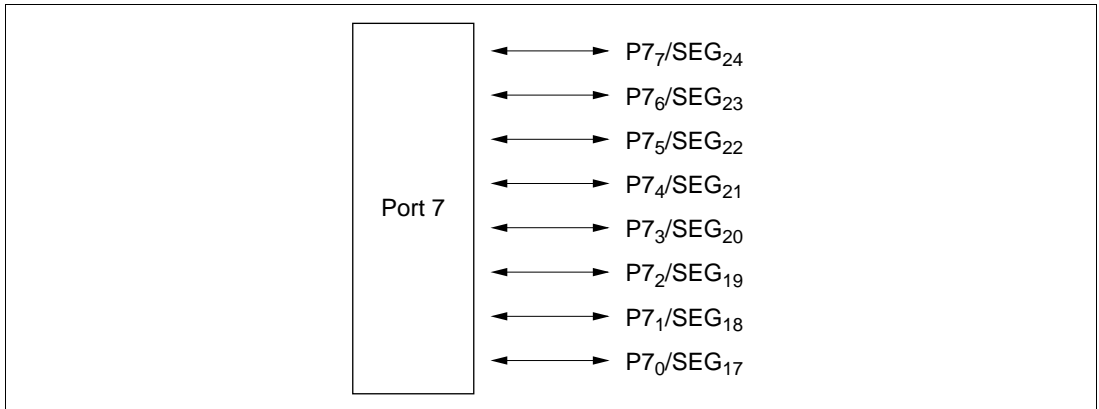

Figure 8.6 Port 7 Pin Configuration

8.7.2 Register Configuration and Description

Table 8.17 shows the port 7 register configuration.

Table 8.17 Port 7 Registers

| Name | Abbrev. | R/W | Initial Value | Address |
|-------------------------|---------|-----|---------------|---------|
| Port data register 7 | PDR7 | R/W | H'00 | H'FFDA |
| Port control register 7 | PCR7 | W | H'00 | H'FFEA |

1. Port data register 7 (PDR7)

| Bit | 7 | 6 | 5 | 4 | 3 | 2 | 1 | 0 |
|---------------|-----------------|-----------------|-----------------|-----------------|-----------------|-----------------|-----------------|-----------------|
| | P7 ₇ | P7 ₆ | P7 ₅ | P7 ₄ | P7 ₃ | P7 ₂ | P7 ₁ | P7 ₀ |
| Initial value | 0 | 0 | 0 | 0 | 0 | 0 | 0 | 0 |
| Read/Write | R/W | R/W | R/W | R/W | R/W | R/W | R/W | R/W |

PDR7 is an 8-bit register that stores data for port 7 pins P7₇ to P7₀. If port 7 is read while PCR7 bits are set to 1, the values stored in PDR7 are read, regardless of the actual pin states. If port 7 is read while PCR7 bits are cleared to 0, the pin states are read.

Upon reset, PDR7 is initialized to H'00.

2. Port control register 7 (PCR7)

| Bit | 7 | 6 | 5 | 4 | 3 | 2 | 1 | 0 |
|---------------|-------------------|-------------------|-------------------|-------------------|-------------------|-------------------|-------------------|-------------------|
| | PCR7 ₇ | PCR7 ₆ | PCR7 ₅ | PCR7 ₄ | PCR7 ₃ | PCR7 ₂ | PCR7 ₁ | PCR7 ₀ |
| Initial value | 0 | 0 | 0 | 0 | 0 | 0 | 0 | 0 |
| Read/Write | W | W | W | W | W | W | W | W |

PCR7 is an 8-bit register for controlling whether each of the port 7 pins P7₇ to P7₀ functions as an input pin or output pin. Setting a PCR7 bit to 1 makes the corresponding pin an output pin, while clearing the bit to 0 makes the pin an input pin. PCR7 and PDR7 settings are valid when the corresponding pins are designated for general-purpose input/output by bits SGS3 to SGS0 in LPCR.

Upon reset, PCR7 is initialized to H'00.

PCR7 is a write-only register, which always reads as all 1s.

8.7.3 Pin Functions

Table 8.18 shows the port 7 pin functions.

Table 8.18 Port 7 Pin Functions

| Pin | Pin Functions and Selection Method | | | |
|---|--|---------------------------|----------------------------|--------------------------------|
| P7 ₇ /SEG ₂₄ to P7 ₀ /SEG ₁₇ | The pin function depends on bit PCR7 _n in PCR7 and bits SGS3 to SGS0 in LPCR. (n = 7 to 0) | | | |
| | SEGS3 to SEGS0 | 00** | | 01**, 1*** |
| | PCR7 _n | 0 | 1 | * |
| | Pin function | P7 _n input pin | P7 _n output pin | SEG _{n+17} output pin |

*: Don't care

8.7.4 Pin States

Table 8.19 shows the port 7 pin states in each operating mode.

Table 8.19 Port 7 Pin States

| Pins | Reset | Sleep | Subsleep | Standby | Watch | Subactive | Active |
|---|----------------|------------------------|------------------------|----------------|------------------------|------------|------------|
| P7 ₇ /SEG ₂₄ to P7 ₀ /SEG ₁₇ | High-impedance | Retains previous state | Retains previous state | High-impedance | Retains previous state | Functional | Functional |

8.8 Port 8

8.8.1 Overview

Port 8 is an 8-bit I/O port configured as shown in figure 8.7.

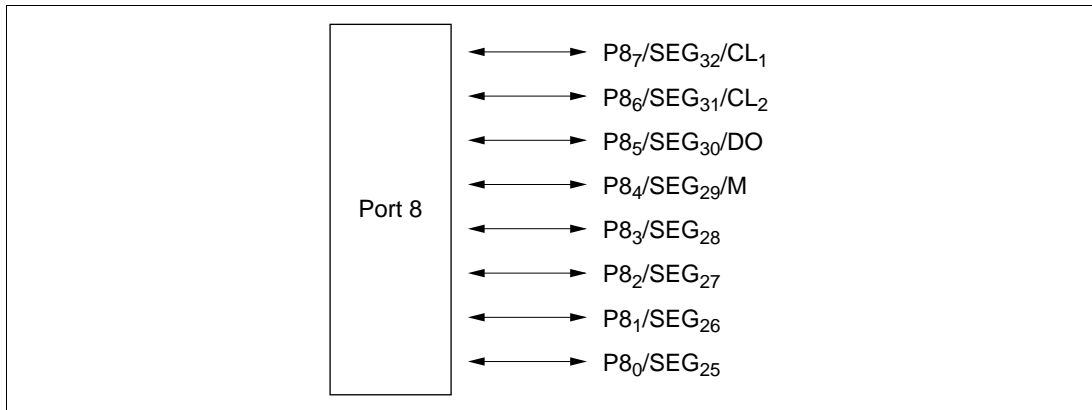

Figure 8.7 Port 8 Pin Configuration

8.8.2 Register Configuration and Description

Table 8.20 shows the port 8 register configuration.

Table 8.20 Port 8 Registers

| Name | Abbrev. | R/W | Initial Value | Address |
|-------------------------|---------|-----|---------------|---------|
| Port data register 8 | PDR8 | R/W | H'00 | H'FFDB |
| Port control register 8 | PCR8 | W | H'00 | H'FFEB |

1. Port data register 8 (PDR8)

| Bit | 7 | 6 | 5 | 4 | 3 | 2 | 1 | 0 |
|---------------|-----------------|-----------------|-----------------|-----------------|-----------------|-----------------|-----------------|-----------------|
| | P8 ₇ | P8 ₆ | P8 ₅ | P8 ₄ | P8 ₃ | P8 ₂ | P8 ₁ | P8 ₀ |
| Initial value | 0 | 0 | 0 | 0 | 0 | 0 | 0 | 0 |
| Read/Write | R/W | R/W | R/W | R/W | R/W | R/W | R/W | R/W |

PDR8 is an 8-bit register that stores data for port 8 pins P8₇ to P8₀. If port 8 is read while PCR8 bits are set to 1, the values stored in PDR8 are read, regardless of the actual pin states. If port 8 is read while PCR8 bits are cleared to 0, the pin states are read.

Upon reset, PDR8 is initialized to H'00.

2. Port control register 8 (PCR8)

| Bit | 7 | 6 | 5 | 4 | 3 | 2 | 1 | 0 |
|---------------|-------------------|-------------------|-------------------|-------------------|-------------------|-------------------|-------------------|-------------------|
| | PCR8 ₇ | PCR8 ₆ | PCR8 ₅ | PCR8 ₄ | PCR8 ₃ | PCR8 ₂ | PCR8 ₁ | PCR8 ₀ |
| Initial value | 0 | 0 | 0 | 0 | 0 | 0 | 0 | 0 |
| Read/Write | W | W | W | W | W | W | W | W |

PCR8 is an 8-bit register for controlling whether each of the port 8 pins P8₇ to P8₀ functions as an input or output pin. Setting a PCR8 bit to 1 makes the corresponding pin an output pin, while clearing the bit to 0 makes the pin an input pin. PCR8 and PDR8 settings are valid when the corresponding pins are designated for general-purpose input/output by bits SGS3 to SGS0 in LPCR.

Upon reset, PCR8 is initialized to H'00.

PCR8 is a write-only register, which is always read as all 1s.

8.8.3 Pin Functions

Table 8.21 shows the port 8 pin functions.

Table 8.21 Port 8 Pin Functions

| Pin | Pin Functions and Selection Method | | | | |
|---|--|---------------------------|----------------------------|--------------------------------|----------------------------|
| P8 ₇ /SEG ₃₂ / CL ₁ | The pin function depends on bit PCR ₈₇ in PCR8 and bits SGX and SGS3 to SGS0 in LPCR. | | | | |
| | SEGS3 to SEGS0 | 000* | | 001*, 01**, 1*** | * |
| | SGX | 0 | | 0 | 1 |
| | PCR ₈₇ | 0 | 1 | * | * |
| | Pin function | P8 ₇ input pin | P8 ₇ output pin | SEG ₃₂ output pin | CL ₁ output pin |
| P8 ₆ /SEG ₃₁ / CL ₂ | The pin function depends on bit PCR ₈₆ in PCR8 and bits SGX and SGS3 to SGS0 in LPCR. | | | | |
| | SEGS3 to SEGS0 | 000* | | 001*, 01**, 1*** | * |
| | SGX | 0 | | 0 | 1 |
| | PCR ₈₆ | 0 | 1 | * | * |
| | Pin function | P8 ₆ input pin | P8 ₆ output pin | SEG ₃₁ output pin | CL ₂ output pin |
| P8 ₅ /SEG ₃₀ / D0 | The pin function depends on bit PCR ₈₅ in PCR8 and bits SGX and SGS3 to SGS0 in LPCR. | | | | |
| | SEGS3 to SEGS0 | 000* | | 001*, 01**, 1*** | * |
| | SGX | 0 | | 0 | 1 |
| | PCR ₉₅ | 0 | 1 | * | * |
| | Pin function | P8 ₅ input pin | P8 ₅ output pin | SEG ₃₀ output pin | D0 output pin |
| P8 ₄ /SEG ₂₉ / M | The pin function depends on bit PCR ₈₄ in PCR8 and bits SGX and SGS3 to SGS0 in LPCR. | | | | |
| | SEGS3 to SEGS0 | 000* | | 001*, 01**, 1*** | * |
| | SGX | 0 | | 0 | 1 |
| | PCR ₉₄ | 0 | 1 | * | * |
| | Pin function | P8 ₄ input pin | P8 ₄ output pin | SEG ₂₉ output pin | M output pin |
| P8 ₃ /SEG ₂₈ to P8 ₀ /SEG ₂₅ | The pin function depends on bit PCR _{8n} in PCR8 and bits SGS3 to SGS0 in LPCR. (n = 3 to 0) | | | | |
| | SEGS3 to SEGS0 | 000* | | 001*, 01**, 1*** | * |
| | PCR _{8n} | 0 | 1 | * | * |
| | Pin function | P8 _n input pin | P8 _n output pin | SEG _{n+25} output pin | |

*: Don't care

8.8.4 Pin States

Table 8.22 shows the port 8 pin states in each operating mode.

Table 8.22 Port 8 Pin States

| Pins | Reset | Sleep | Subsleep | Standby | Watch | Subactive | Active |
|---|----------------|------------------------|------------------------|----------------|------------------------|------------------|---------------|
| P8 ₇ /SEG ₃₂ /CL ₁ | High-impedance | Retains previous state | Retains previous state | High-impedance | Retains previous state | Functional | Functional |
| P8 ₆ /SEG ₃₁ /CL ₂ | | | | | | | |
| P8 ₅ /SEG ₃₀ /DO | | | | | | | |
| P8 ₄ /SEG ₂₉ /M | | | | | | | |
| P8 ₃ /SEG ₂₈ to | | | | | | | |
| P8 ₀ /SEG ₂₅ | | | | | | | |

8.9 Port A

8.9.1 Overview

Port A is a 4-bit I/O port, configured as shown in figure 8.8.

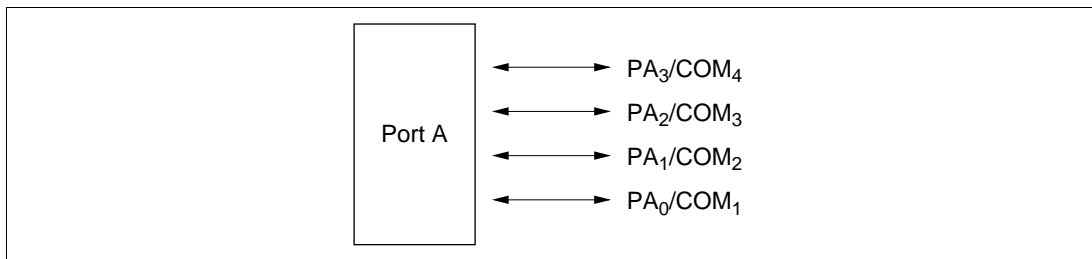

Figure 8.8 Port A Pin Configuration

8.9.2 Register Configuration and Description

Table 8.23 shows the port A register configuration.

Table 8.23 Port A Registers

| Name | Abbrev. | R/W | Initial Value | Address |
|-------------------------|---------|-----|---------------|---------|
| Port data register A | PDRA | R/W | H'F0 | H'FFDD |
| Port control register A | PCRA | W | H'F0 | H'FFED |

1. Port data register A (PDRA)

| | | | | | | | | |
|---------------|---|---|---|---|-----------------|-----------------|-----------------|-----------------|
| Bit | 7 | 6 | 5 | 4 | 3 | 2 | 1 | 0 |
| | — | — | — | — | PA ₃ | PA ₂ | PA ₁ | PA ₀ |
| Initial value | 1 | 1 | 1 | 1 | 0 | 0 | 0 | 0 |
| Read/Write | — | — | — | — | R/W | R/W | R/W | R/W |

PDRA is an 8-bit register that stores data for port A pins PA₃ to PA₀. If port A is read while PCRA bits are set to 1, the values stored in PDRA are read, regardless of the actual pin states. If port A is read while PCRA bits are cleared to 0, the pin states are read.

Upon reset, PDRA is initialized to H'F0.

2. Port control register A (PCRA)

| Bit | 7 | 6 | 5 | 4 | 3 | 2 | 1 | 0 |
|---------------|---|---|---|---|-------------------|-------------------|-------------------|-------------------|
| | — | — | — | — | PCRA ₃ | PCRA ₂ | PCRA ₁ | PCRA ₀ |
| Initial value | 1 | 1 | 1 | 1 | 0 | 0 | 0 | 0 |
| Read/Write | — | — | — | — | R/W | R/W | R/W | R/W |

PCRA controls whether each of port A pins PA₃ to PA₀ functions as an input pin or output pin. Setting a PCRA bit to 1 makes the corresponding pin an output pin, while clearing the bit to 0 makes the pin an input pin. PCRA and PDRA settings are valid when the corresponding pins are designated for general-purpose input/output by LPCR.

Upon reset, PCRA is initialized to 0xF0.

PCRA is a write-only register, which always reads all 1s.

8.9.3 Pin Functions

Table 8.24 shows the port A pin functions.

Table 8.24 Port A Pin Functions

| Pin | Pin Functions and Selection Method | | | |
|-----------------------------------|--|---------------------------|----------------------------|-----------------------------|
| PA ₃ /COM ₄ | The pin function depends on bit PCRA ₃ in PCRA and bits SGS3 to SGS0. | | | |
| | SEGS3 to SEGS0 | 0000 | 0000 | Not 0000 |
| | PCRA ₃ | 0 | 1 | * |
| | Pin function | PA ₃ input pin | PA ₃ output pin | COM ₄ output pin |
| PA ₂ /COM ₃ | The pin function depends on bit PCRA ₂ in PCRA and bits SGS3 to SGS0. | | | |
| | SEGS3 to SEGS0 | 0000 | 0000 | Not 0000 |
| | PCRA ₂ | 0 | 1 | * |
| | Pin function | PA ₂ input pin | PA ₂ output pin | COM ₃ output pin |
| PA ₁ /COM ₂ | The pin function depends on bit PCRA ₁ in PCRA and bits SGS3 to SGS0. | | | |
| | SEGS3 to SEGS0 | 0000 | 0000 | Not 0000 |
| | PCRA ₁ | 0 | 1 | * |
| | Pin function | PA ₁ input pin | PA ₁ output pin | COM ₂ output pin |
| PA ₀ /COM ₁ | The pin function depends on bit PCRA ₀ in PCRA and bits SGS3 to SGS0. | | | |
| | SEGS3 to SEGS0 | 0000 | | Not 0000 |
| | PCRA ₀ | 0 | 1 | * |
| | Pin function | PA ₀ input pin | PA ₀ output pin | COM ₁ output pin |

*: Don't care

8.9.4 Pin States

Table 8.25 shows the port A pin states in each operating mode.

Table 8.25 Port A Pin States

| Pins | Reset | Sleep | Subsleep | Standby | Watch | Subactive | Active |
|-----------------------------------|----------------|--------------|-----------------|----------------|--------------|------------------|---------------|
| PA ₃ /COM ₄ | High-impedance | Retains | Retains | High- | Retains | Functional | Functional |
| PA ₂ /COM ₃ | | previous | previous | impedance | previous | | |
| PA ₁ /COM ₂ | | state | state | | state | | |
| PA ₀ /COM ₁ | | | | | | | |

8.10 Port B

8.10.1 Overview

Port B is an 8-bit input-only port, configured as shown in figure 8.9.

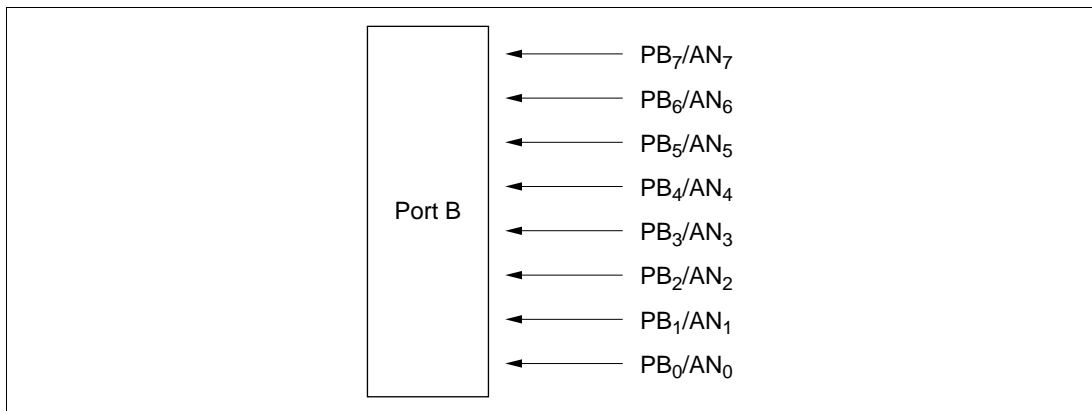

Figure 8.9 Port B Pin Configuration

8.10.2 Register Configuration and Description

Table 8.26 shows the port B register configuration.

Table 8.26 Port B Register

| Name | Abbrev. | R/W | Address |
|----------------------|---------|-----|---------|
| Port data register B | PDRB | R | H'FFDE |

Port Data Register B (PDRB)

| Bit | 7 | 6 | 5 | 4 | 3 | 2 | 1 | 0 |
|------------|-----------------|-----------------|-----------------|-----------------|-----------------|-----------------|-----------------|-----------------|
| | PB ₇ | PB ₆ | PB ₅ | PB ₄ | PB ₃ | PB ₂ | PB ₁ | PB ₀ |
| Read/Write | R | R | R | R | R | R | R | R |

Reading PDRB always gives the pin states. However, if a port B pin is selected as an analog input channel for the A/D converter by AMR bits CH3 to CH0, that pin reads 0 regardless of the input voltage.

8.11 Input/Output Data Inversion Function

8.11.1 Overview

With input pins \overline{WKP}_0 to \overline{WKP}_7 , RXD_{31} , and RXD_{32} , and output pins TXD_{31} and TXD_{32} , the data can be handled in inverted form.

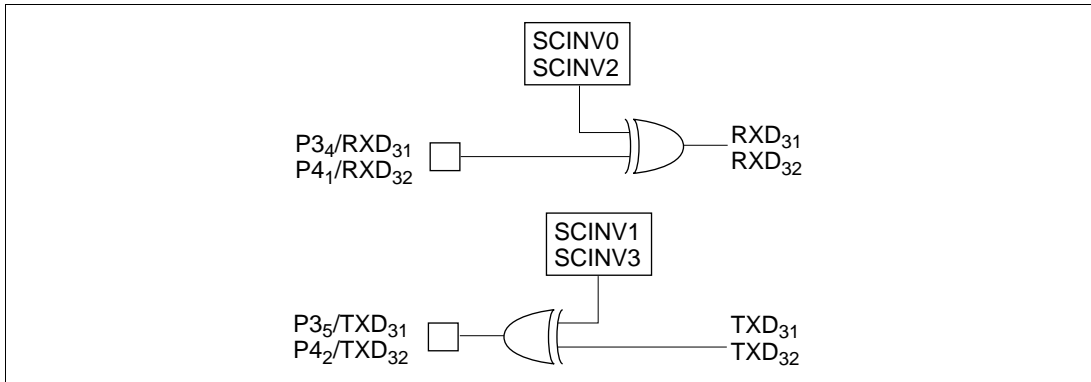

Figure 8.10 Input/Output Data Inversion Function

8.11.2 Register Configuration and Descriptions

Table 8.27 shows the registers used by the input/output data inversion function.

Table 8.27 Register Configuration

| Name | Abbreviation | R/W | Address |
|------------------------------|--------------|-----|---------|
| Serial port control register | SPCR | R/W | H'FF91 |

Serial Port Control Register (SPCR)

| Bit | 7 | 6 | 5 | 4 | 3 | 2 | 1 | 0 |
|---------------|---|---|-------|-------|--------|--------|--------|--------|
| | — | — | SPC32 | SPC31 | SCINV3 | SCINV2 | SCINV1 | SCINV0 |
| Initial value | 1 | 1 | 0 | 0 | 0 | 0 | 0 | 0 |
| Read/Write | — | — | R/W | R/W | R/W | R/W | R/W | R/W |

SPCR is an 8-bit readable/writable register that performs RXD_{31} , RXD_{32} , TXD_{31} , and TXD_{32} pin input/output data inversion switching. SPCR is initialized to H'C0 by a reset.

Bit 0: RXD₃₁ pin input data inversion switch

Bit 0 specifies whether or not RXD₃₁ pin input data is to be inverted.

Bit 0

| SCINV0 | Description | |
|---------------|--|-----------------|
| 0 | RXD ₃₁ input data is not inverted | (initial value) |
| 1 | RXD ₃₁ input data is inverted | |

Bit 1: TXD₃₁ pin output data inversion switch

Bit 1 specifies whether or not TXD₃₁ pin output data is to be inverted.

Bit 1

| SCINV1 | Description | |
|---------------|---|-----------------|
| 0 | TXD ₃₁ output data is not inverted | (initial value) |
| 1 | TXD ₃₁ output data is inverted | |

Bit 2: RXD₃₂ pin input data inversion switch

Bit 2 specifies whether or not RXD₃₂ pin input data is to be inverted.

Bit 2

| SCINV2 | Description | |
|---------------|--|-----------------|
| 0 | RXD ₃₂ input data is not inverted | (initial value) |
| 1 | RXD ₃₂ input data is inverted | |

Bit 3: TXD₃₂ pin output data inversion switch

Bit 3 specifies whether or not TXD₃₂ pin output data is to be inverted.

Bit 3

| SCINV3 | Description | |
|---------------|---|-----------------|
| 0 | TXD ₃₂ output data is not inverted | (initial value) |
| 1 | TXD ₃₂ output data is inverted | |

Bit 4: P3₅/TXD₃₁ pin function switch (SPC31)

This bit selects whether pin P3₅/TXD₃₁ is used as P3₅ or as TXD₃₁.

Bit 4**SPC31****Description**

| | Description | |
|---|--|-----------------|
| 0 | Functions as P3 ₅ I/O pin | (initial value) |
| 1 | Functions as TXD ₃₁ output pin* | |

Note: * Set the TE bit in SCR3 after setting this bit to 1.

Bit 5: P4₂/TXD₃₂ pin function switch (SPC32)

This bit selects whether pin P4₂/TXD₃₂ is used as P4₂ or as TXD₃₂.

Bit 5**SPC32****Description**

| | Description | |
|---|--|-----------------|
| 0 | Functions as P4 ₂ I/O pin | (initial value) |
| 1 | Functions as TXD ₃₂ output pin* | |

Note: * Set the TE bit in SCR3 after setting this bit to 1.

Bits 7 and 6: Reserved bits

Bits 7 and 6 are reserved; they are always read as 1 and cannot be modified.

8.11.3 Note on Modification of Serial Port Control Register

When a serial port control register is modified, the data being input or output up to that point is inverted immediately after the modification, and an invalid data change is input or output. When modifying a serial port control register, do so in a state in which data changes are invalidated.

Section 9 Timers

9.1 Overview

The H8/3864 Series provides six timers: timers A, C, F, G, and a watchdog timer, and an asynchronous event counter. The functions of these timers are outlined in table 9.1.

Table 9.1 Timer Functions

| Name | Functions | Internal Clock | Event Input Pin | Waveform Output Pin | Remarks |
|---------|--|---|-----------------|---------------------|---|
| Timer A | • 8-bit interval timer | $\phi/8$ to $\phi/8192$ | — | — | |
| | • Interval function | (8 choices) | | | |
| | • Time base | $\phi_w/128$ (choice of 4 overflow periods) | | | |
| | • Clock output | $\phi/4$ to $\phi/32$ $\phi_w, \phi_w/4$ to $\phi_w/32$ (9 choices) | — | TMOW | |
| Timer C | • 8-bit timer | $\phi/4$ to $\phi/8192, \phi_w/4$ | TMIC | — | Up-count/down-count controllable by software or hardware |
| | • Interval function | (7 choices) | | | |
| | • Event counting function | | | | |
| | • Up-count/down-count selectable | | | | |
| Timer F | 16-bit timer | $\phi/4$ to $\phi/32, \phi_w/4$ | TMIF | TMOFL | |
| | Event counting function Also usable as two independent 8-bit timers Output compare output function | (4 choices) | | TMOFH | |
| Timer G | • 8-bit timer | $\phi/2$ to $\phi/64, \phi_w/4$ | TMIG | — | <ul style="list-style-type: none"> • Counter clearing option • Built-in capture input signal noise canceler |
| | • Input capture function | (4 choices) | | | |
| | • Interval function | | | | |

Table 9.1 Timer Functions (cont)

| Name | Functions | Internal Clock | Event Input Pin | Waveform Output Pin | Remarks |
|----------------------------|--|----------------------------|-----------------|---------------------|---------|
| Watchdog timer | <ul style="list-style-type: none">Reset signal generated when 8-bit counter overflows | $\phi/8192$ $\phi_w/32$ | — | — | |
| Asynchronous event counter | <ul style="list-style-type: none">16-bit counterAlso usable as two independent 8-bit countersCounts events asynchronous to ϕ and ϕ_w | — | AEVL AEVH | — | |

9.2 Timer A

9.2.1 Overview

Timer A is an 8-bit timer with interval timing and real-time clock time-base functions. The clock time-base function is available when a 32.768-kHz crystal oscillator is connected. A clock signal divided from 32.768 kHz, from 38.4 kHz (if a 38.4 kHz crystal oscillator is connected), or from the system clock, can be output at the TMOW pin.

1. Features

Features of timer A are given below.

- Choice of eight internal clock sources ($\phi/8192$, $\phi/4096$, $\phi/2048$, $\phi/512$, $\phi/256$, $\phi/128$, $\phi/32$, $\phi/8$).
- Choice of four overflow periods (1 s, 0.5 s, 0.25 s, 31.25 ms) when timer A is used as a clock time base (using a 32.768 kHz crystal oscillator).
- An interrupt is requested when the counter overflows.
- Any of nine clock signals can be output at the TMOW pin: 32.768 kHz divided by 32, 16, 8, or 4 (1 kHz, 2 kHz, 4 kHz, 8 kHz) or 38.4 kHz divided by 32, 16, 8, or 4 (1.2 kHz, 2.4 kHz, 4.8 kHz, 9.6 kHz), and the system clock divided by 32, 16, 8, or 4.
- Use of module standby mode enables this module to be placed in standby mode independently when not used.

2. Block diagram

Figure 9.1 shows a block diagram of timer A.

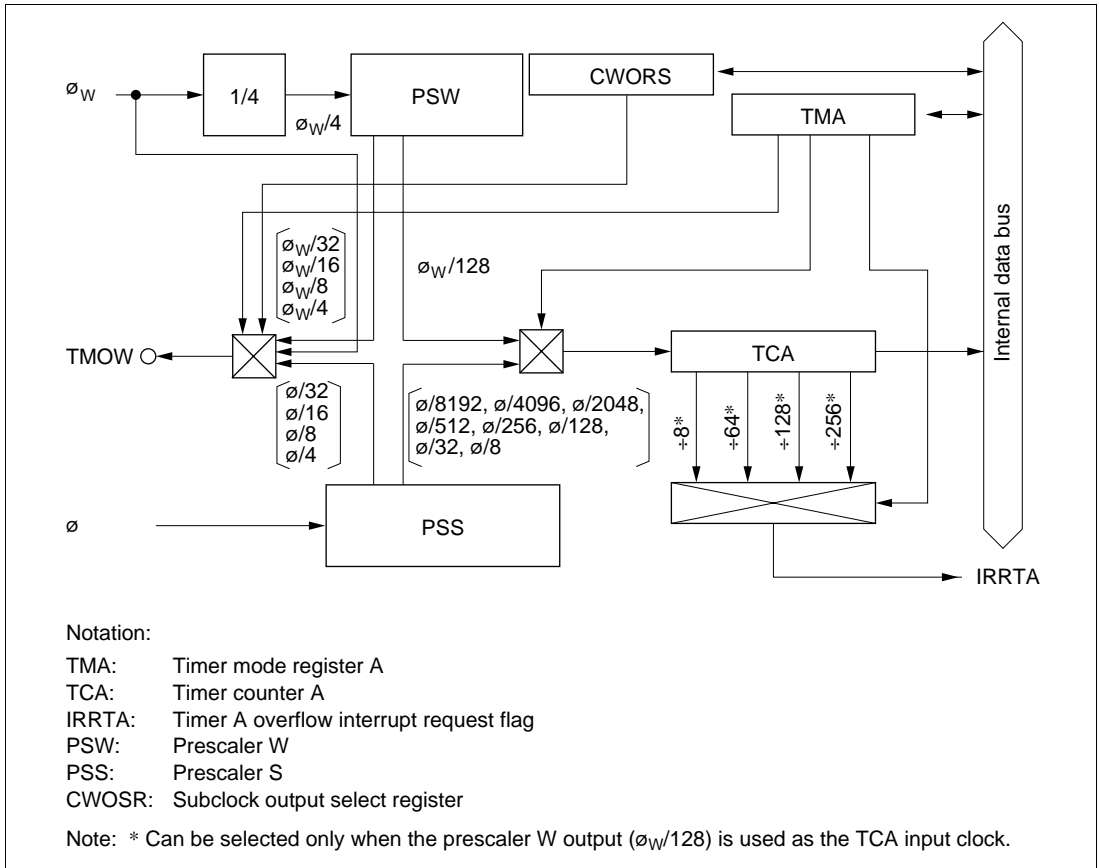

Figure 9.1 Block Diagram of Timer A

3. Pin configuration

Table 9.2 shows the timer A pin configuration.

Table 9.2 Pin Configuration

| Name | Abbrev. | I/O | Function |
|--------------|---------|--------|--|
| Clock output | TMOW | Output | Output of waveform generated by timer A output circuit |

4. Register configuration

Table 9.3 shows the register configuration of timer A.

Table 9.3 Timer A Registers

| Name | Abbrev. | R/W | Initial Value | Address |
|---------------------------------|---------|-----|---------------|---------|
| Timer mode register A | TMA | R/W | H'10 | H'FFB0 |
| Timer counter A | TCA | R | H'00 | H'FFB1 |
| Clock stop register 1 | CKSTPR1 | R/W | H'FF | H'FFFA |
| Subclock output select register | CWOSR | R/W | H'FE | H'FF92 |

9.2.2 Register Descriptions

1. Timer mode register A (TMA)

| | | | | | | | | |
|---------------|------|------|------|---|------|------|------|------|
| Bit | 7 | 6 | 5 | 4 | 3 | 2 | 1 | 0 |
| | TMA7 | TMA6 | TMA5 | — | TMA3 | TMA2 | TMA1 | TMA0 |
| Initial value | 0 | 0 | 0 | 1 | 0 | 0 | 0 | 0 |
| Read/Write | R/W | R/W | R/W | — | R/W | R/W | R/W | R/W |

TMA is an 8-bit read/write register for selecting the prescaler, input clock, and output clock.

Upon reset, TMA is initialized to H'10.

Bits 7 to 5: Clock output select (TMA7 to TMA5)

Bits 7 to 5 choose which of eight clock signals is output at the TMOW pin. The system clock divided by 32, 16, 8, or 4 can be output in active mode and sleep mode. A 32.768 kHz or 38.4 kHz signal divided by 32, 16, 8, or 4 can be output in active mode, sleep mode, and subactive mode. ϕ_w is output in all modes except the reset state.

| CWOSR | TMA | | | Clock Output |
|-------|---------------|---------------|---------------|--------------|
| | Bit 7 TMA7 | Bit 6 TMA6 | Bit 5 TMA5 | |
| 0 | 0 | 0 | 0 | $\phi/32$ |
| | | | 1 | $\phi/16$ |
| | | 1 | 0 | $\phi/8$ |
| | | | 1 | $\phi/4$ |
| | 1 | 0 | 0 | $\phi_w/32$ |
| | | | 1 | $\phi_w/16$ |
| | | 1 | 0 | $\phi_w/8$ |
| | | | 1 | $\phi_w/4$ |
| 1 | * | * | * | ϕ_w |

*: Don't care

Bit 4: Reserved bit

Bit 4 is reserved; it is always read as 1, and cannot be modified.

Bits 3 to 0: Internal clock select (TMA3 to TMA0)

Bits 3 to 0 select the clock input to TCA. The selection is made as follows.

| Bit 3 TMA3 | Bit 2 TMA2 | Bit 1 TMA1 | Bit 0 TMA0 | Description | |
|---------------|---------------|---------------|---------------|---|--|
| | | | | Prescaler and Divider Ratio or Overflow Period | Function |
| 0 | 0 | 0 | 0 | PSS, $\phi/8192$ | (initial value) Interval timer |
| | | | 1 | PSS, $\phi/4096$ | |
| | | 1 | 0 | PSS, $\phi/2048$ | |
| | | | 1 | PSS, $\phi/512$ | |
| | 1 | 0 | 0 | PSS, $\phi/256$ | |
| | | | 1 | PSS, $\phi/128$ | |
| | | 1 | 0 | PSS, $\phi/32$ | |
| | | | 1 | PSS, $\phi/8$ | |
| 1 | 0 | 0 | 0 | PSW, 1 s | Clock time base (when using 32.768 kHz) |
| | | | 1 | PSW, 0.5 s | |
| | | 1 | 0 | PSW, 0.25 s | |
| | | | 1 | PSW, 0.03125 s | |
| | 1 | 0 | 0 | PSW and TCA are reset | |
| | | | 1 | | |
| | | 1 | 0 | | |
| | | | 1 | | |

2. Timer counter A (TCA)

| | | | | | | | | |
|---------------|------|------|------|------|------|------|------|------|
| Bit | 7 | 6 | 5 | 4 | 3 | 2 | 1 | 0 |
| | TCA7 | TCA6 | TCA5 | TCA4 | TCA3 | TCA2 | TCA1 | TCA0 |
| Initial value | 0 | 0 | 0 | 0 | 0 | 0 | 0 | 0 |
| Read/Write | R | R | R | R | R | R | R | R |

TCA is an 8-bit read-only up-counter, which is incremented by internal clock input. The clock source for input to this counter is selected by bits TMA3 to TMA0 in timer mode register A (TMA). TCA values can be read by the CPU in active mode, but cannot be read in subactive mode. When TCA overflows, the IRRTA bit in interrupt request register 1 (IRR1) is set to 1.

TCA is cleared by setting bits TMA3 and TMA2 of TMA to 11.

Upon reset, TCA is initialized to H'00.

3. Clock stop register 1 (CKSTPR1)

| | | | | | | | | |
|----------------|-----|----------|----------|---------|---------|---------|---------|---------|
| Bit: | 7 | 6 | 5 | 4 | 3 | 2 | 1 | 0 |
| | — | S31CKSTP | S32CKSTP | ADCKSTP | TGCKSTP | TFCKSTP | TCCKSTP | TACKSTP |
| Initial value: | 1 | 1 | 1 | 1 | 1 | 1 | 1 | 1 |
| Read/Write: | R/W | R/W | R/W | R/W | R/W | R/W | R/W | R/W |

CKSTPR1 is an 8-bit read/write register that performs module standby mode control for peripheral modules. Only the bit relating to timer A is described here. For details of the other bits, see the sections on the relevant modules.

Bit 0: Timer A module standby mode control (TACKSTP)

Bit 0 controls setting and clearing of module standby mode for timer A.

| TACKSTP | Description |
|---------|--|
| 0 | Timer A is set to module standby mode |
| 1 | Timer A module standby mode is cleared (initial value) |

Subclock Output Select Register (CWOSR)

| | | | | | | | | |
|----------------|---|---|---|---|---|---|---|------|
| Bit: | 7 | 6 | 5 | 4 | 3 | 2 | 1 | 0 |
| | — | — | — | — | — | — | — | CWOS |
| Initial value: | 1 | 1 | 1 | 1 | 1 | 1 | 1 | 0 |
| Read/Write: | R | R | R | R | R | R | R | R/W |

CWOSR is an 8-bit read/write register that selects the clock to be output from the TMOW pin.

CWOSR is initialized to H'FE by a reset.

Bits 7 to 1: Reserved bits

Bits 7 to 1 are reserved; they are always read as 1 and cannot be modified.

Bit 0: TMOW pin clock select (CWOS)

Bit 0 selects the clock to be output from the TMOW pin.

Bit 0

| CWOS | Description |
|------|---|
| 0 | Clock output from timer A is output (see TMA) (initial value) |
| 1 | \emptyset_w is output |

9.2.3 Timer Operation

1. Interval timer operation

When bit TMA3 in timer mode register A (TMA) is cleared to 0, timer A functions as an 8-bit interval timer.

Upon reset, TCA is cleared to H'00 and bit TMA3 is cleared to 0, so up-counting and interval timing resume immediately. The clock input to timer A is selected by bits TMA2 to TMA0 in TMA; any of eight internal clock signals output by prescaler S can be selected.

After the count value in TCA reaches H'FF, the next clock signal input causes timer A to overflow, setting bit IRRTA to 1 in interrupt request register 1 (IRR1). If IENTA = 1 in interrupt enable register 1 (IENR1), a CPU interrupt is requested.*

At overflow, TCA returns to H'00 and starts counting up again. In this mode timer A functions as an interval timer that generates an overflow output at intervals of 256 input clock pulses.

Note: * For details on interrupts, see 3.3, Interrupts.

2. Real-time clock time base operation

When bit TMA3 in TMA is set to 1, timer A functions as a real-time clock time base by counting clock signals output by prescaler W. The overflow period of timer A is set by bits TMA1 and TMA0 in TMA. A choice of four periods is available. In time base operation (TMA3 = 1), setting bit TMA2 to 1 clears both TCA and prescaler W to their initial values of H'00.

3. Clock output

Setting bit TMOW in port mode register 1 (PMR1) to 1 causes a clock signal to be output at pin TMOW. Nine different clock output signals can be selected by means of bits TMA7 to TMA5 in TMA and bit CWOS in CWOSR. The system clock divided by 32, 16, 8, or 4 can be output in active mode and sleep mode. A 32.768 kHz or 38.4 kHz signal divided by 32, 16, 8, or 4 can be output in active mode, sleep mode, watch mode, subactive mode, and subsleep mode. The 32.768 kHz or 38.4 kHz clock is output in all modes except the reset state.

9.2.4 Timer A Operation States

Table 9.4 summarizes the timer A operation states.

Table 9.4 Timer A Operation States

| Operation Mode | Reset | Active | Sleep | Watch | Sub-active | Sub-sleep | Standby | Module Standby |
|-----------------|-------|-----------|-----------|-----------|------------|-----------|----------|----------------|
| TCA Interval | Reset | Functions | Functions | Halted | Halted | Halted | Halted | Halted |
| Clock time base | Reset | Functions | Functions | Functions | Functions | Functions | Halted | Halted |
| TMA | Reset | Functions | Retained | Retained | Functions | Retained | Retained | Retained |

Note: When the real-time clock time base function is selected as the internal clock of TCA in active mode or sleep mode, the internal clock is not synchronous with the system clock, so it is synchronized by a synchronizing circuit. This may result in a maximum error of $1/\emptyset$ (s) in the count cycle.

9.3 Timer C

9.3.1 Overview

Timer C is an 8-bit timer that increments each time a clock pulse is input. This timer has two operation modes, interval and auto reload.

1. Features

Features of timer C are given below.

- Choice of seven internal clock sources ($\phi/8192$, $\phi/2048$, $\phi/512$, $\phi/64$, $\phi/16$, $\phi/4$, $\phi_w/4$) or an external clock (can be used to count external events).
- An interrupt is requested when the counter overflows.
- Up/down-counter switching is possible by hardware or software.
- Subactive mode and subsleep mode operation is possible when $\phi_w/4$ is selected as the internal clock, or when an external clock is selected.
- Use of module standby mode enables this module to be placed in standby mode independently when not used.

2. Block diagram

Figure 9.2 shows a block diagram of timer C.

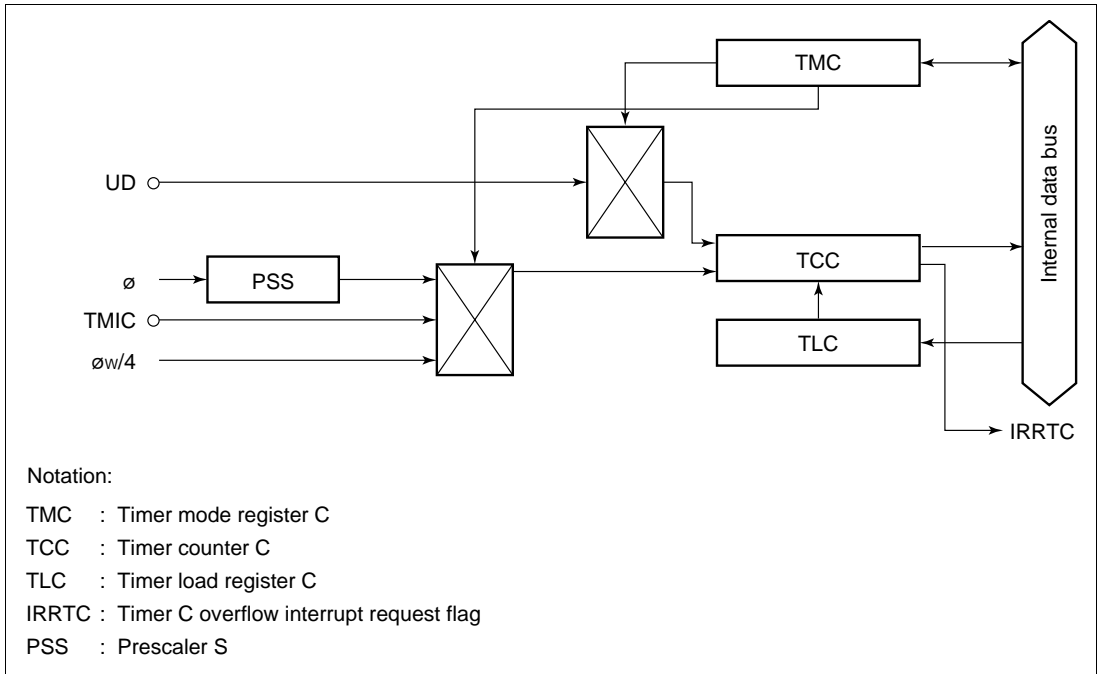

Figure 9.2 Block Diagram of Timer C

3. Pin configuration

Table 9.5 shows the timer C pin configuration.

Table 9.5 Pin Configuration

| Name | Abbrev. | I/O | Function |
|---------------------------------|---------|-------|----------------------------------|
| Timer C event input | TMIC | Input | Input pin for event input to TCC |
| Timer C up/down-count selection | UD | Input | Timer C up/down select |

4. Register configuration

Table 9.6 shows the register configuration of timer C.

Table 9.6 Timer C Registers

| Name | Abbrev. | R/W | Initial Value | Address |
|-----------------------|---------|-----|---------------|---------|
| Timer mode register C | TMC | R/W | H'18 | H'FFB4 |
| Timer counter C | TCC | R | H'00 | H'FFB5 |
| Timer load register C | TLC | W | H'00 | H'FFB5 |
| Clock stop register 1 | CKSTPR1 | R/W | H'FF | H'FFFA |

9.3.2 Register Descriptions

1. Timer mode register C (TMC)

| | | | | | | | | |
|---------------|------|------|------|---|---|------|------|------|
| Bit | 7 | 6 | 5 | 4 | 3 | 2 | 1 | 0 |
| | TMC7 | TMC6 | TMC5 | — | — | TMC2 | TMC1 | TMC0 |
| Initial value | 0 | 0 | 0 | 1 | 1 | 0 | 0 | 0 |
| Read/Write | R/W | R/W | R/W | — | — | R/W | R/W | R/W |

TMC is an 8-bit read/write register for selecting the auto-reload function and input clock, and performing up/down-counter control.

Upon reset, TMC is initialized to H'18.

Bit 7: Auto-reload function select (TMC7)

Bit 7 selects whether timer C is used as an interval timer or auto-reload timer.

Bit 7

TMC7

Description

| | Description | |
|---|----------------------------------|-----------------|
| 0 | Interval timer function selected | (initial value) |
| 1 | Auto-reload function selected | |

Bits 6 and 5: Counter up/down control (TMC6, TMC5)

Selects whether TCC up/down control is performed by hardware using UD pin input, or whether TCC functions as an up-counter or a down-counter.

Bit 6

TMC6

Bit 5

TMC5

Description

| | | | |
|---|---|---|-----------------|
| 0 | 0 | TCC is an up-counter | (initial value) |
| 0 | 1 | TCC is a down-counter | |
| 1 | * | Hardware control by UD pin input UD pin input high: Down-counter UD pin input low: Up-counter | |

*: Don't care

Bits 4 and 3: Reserved bits

Bits 4 and 3 are reserved; they are always read as 1 and cannot be modified.

Bits 2 to 0: Clock select (TMC2 to TMC0)

Bits 2 to 0 select the clock input to TCC. For external event counting, either the rising or falling edge can be selected.

| Bit 2 TMC2 | Bit 1 TMC1 | Bit 0 TMC0 | Description |
|---------------|---------------|---------------|--|
| 0 | 0 | 0 | Internal clock: $\phi/8192$ (initial value) |
| 0 | 0 | 1 | Internal clock: $\phi/2048$ |
| 0 | 1 | 0 | Internal clock: $\phi/512$ |
| 0 | 1 | 1 | Internal clock: $\phi/64$ |
| 1 | 0 | 0 | Internal clock: $\phi/16$ |
| 1 | 0 | 1 | Internal clock: $\phi/4$ |
| 1 | 1 | 0 | Internal clock: $\phi_w/4$ |
| 1 | 1 | 1 | External event (TMIC): rising or falling edge* |

Note: * The edge of the external event signal is selected by bit IEG1 in the IRQ edge select register (IEGR). See 1. IRQ edge select register (IEGR) in 3.3.2 for details. IRQ2 must be set to 1 in port mode register 1 (PMR1) before setting 111 in bits TMC2 to TMC0.

2. Timer counter C (TCC)

| Bit | 7 | 6 | 5 | 4 | 3 | 2 | 1 | 0 |
|---------------|------|------|------|------|------|------|------|------|
| | TCC7 | TCC6 | TCC5 | TCC4 | TCC3 | TCC2 | TCC1 | TCC0 |
| Initial value | 0 | 0 | 0 | 0 | 0 | 0 | 0 | 0 |
| Read/Write | R | R | R | R | R | R | R | R |

TCC is an 8-bit read-only up-counter, which is incremented by internal clock or external event input. The clock source for input to this counter is selected by bits TMC2 to TMC0 in timer mode register C (TMC). TCC values can be read by the CPU at any time.

When TCC overflows from H'FF to H'00 or to the value set in TLC, or underflows from H'00 to H'FF or to the value set in TLC, the IRRTC bit in IRR2 is set to 1.

TCC is allocated to the same address as TLC.

Upon reset, TCC is initialized to H'00.

3. Timer load register C (TLC)

| | | | | | | | | |
|---------------|------|------|------|------|------|------|------|------|
| Bit | 7 | 6 | 5 | 4 | 3 | 2 | 1 | 0 |
| | TLC7 | TLC6 | TLC5 | TLC4 | TLC3 | TLC2 | TLC1 | TLC0 |
| Initial value | 0 | 0 | 0 | 0 | 0 | 0 | 0 | 0 |
| Read/Write | W | W | W | W | W | W | W | W |

TLC is an 8-bit write-only register for setting the reload value of timer counter C (TCC).

When a reload value is set in TLC, the same value is loaded into timer counter C as well, and TCC starts counting up from that value. When TCC overflows or underflows during operation in auto-reload mode, the TLC value is loaded into TCC. Accordingly, overflow/underflow periods can be set within the range of 1 to 256 input clocks.

The same address is allocated to TLC as to TCC.

Upon reset, TLC is initialized to H'00.

4. Clock stop register 1 (CKSTPR1)

| | | | | | | | | |
|----------------|-----|----------|----------|---------|---------|---------|---------|---------|
| Bit: | 7 | 6 | 5 | 4 | 3 | 2 | 1 | 0 |
| | — | S31CKSTP | S32CKSTP | ADCKSTP | TGCKSTP | TFCKSTP | TCCKSTP | TACKSTP |
| Initial value: | 1 | 1 | 1 | 1 | 1 | 1 | 1 | 1 |
| Read/Write: | R/W | R/W | R/W | R/W | R/W | R/W | R/W | R/W |

CKSTPR1 is an 8-bit read/write register that performs module standby mode control for peripheral modules. Only the bit relating to timer C is described here. For details of the other bits, see the sections on the relevant modules.

Bit 1: Timer C module standby mode control (TCCKSTP)

Bit 1 controls setting and clearing of module standby mode for timer C.

| TCCKSTP | Description |
|---------|--|
| 0 | Timer C is set to module standby mode |
| 1 | Timer C module standby mode is cleared (initial value) |

9.3.3 Timer Operation

1. Interval timer operation

When bit TMC7 in timer mode register C (TMC) is cleared to 0, timer C functions as an 8-bit interval timer.

Upon reset, TCC is initialized to H'00 and TMC to H'18, so TCC continues up-counting as an interval up-counter without halting immediately after a reset. The timer C operating clock is selected from seven internal clock signals output by prescalers S and W, or an external clock input at pin TMIC. The selection is made by bits TMC2 to TMC0 in TMC.

TCC up/down-count control can be performed either by software or hardware. The selection is made by bits TMC6 and TMC5 in TMC.

After the count value in TCC reaches H'FF (H'00), the next clock input causes timer C to overflow (underflow), setting bit IRRTC to 1 in IRR2. If IENTC = 1 in interrupt enable register 2 (IENR2), a CPU interrupt is requested.

At overflow (underflow), TCC returns to H'00 (H'FF) and starts counting up (down) again.

During interval timer operation (TMC7 = 0), when a value is set in timer load register C (TLC), the same value is set in TCC.

Note: For details on interrupts, see 3.3, Interrupts.

2. Auto-reload timer operation

Setting bit TMC7 in TMC to 1 causes timer C to function as an 8-bit auto-reload timer. When a reload value is set in TLC, the same value is loaded into TCC, becoming the value from which TCC starts its count.

After the count value in TCC reaches H'FF (H'00), the next clock signal input causes timer C to overflow/underflow. The TLC value is then loaded into TCC, and the count continues from that value. The overflow/underflow period can be set within a range from 1 to 256 input clocks, depending on the TLC value.

The clock sources, up/down control, and interrupts in auto-reload mode are the same as in interval mode.

In auto-reload mode (TMC7 = 1), when a new value is set in TLC, the TLC value is also set in TCC.

3. Event counter operation

Timer C can operate as an event counter, counting rising or falling edges of an external event signal input at pin TMIC. External event counting is selected by setting bits TMC2 to TMC0 in timer mode register C to all 1s (111).

When timer C is used to count external event input, bit IRQ2 in PMR1 should be set to 1 and bit IEN2 in IENR1 cleared to 0 to disable interrupt IRQ₂ requests.

4. TCC up/down control by hardware

With timer C, TCC up/down control can be performed by UD pin input. When bit TMC6 is set to 1 in TMC, TCC functions as an up-counter when UD pin input is high, and as a down-counter when low.

When using UD pin input, set bit UD to 1 in PMR3.

9.3.4 Timer C Operation States

Table 9.7 summarizes the timer C operation states.

Table 9.7 Timer C Operation States

| Operation Mode | Reset | Active | Sleep | Watch | Sub-active | Sub-sleep | Standby | Module Standby |
|----------------|-------|-----------|-----------|----------|-----------------------|-----------------------|----------|----------------|
| TCC Interval | Reset | Functions | Functions | Halted | Functions/ Halted* | Functions/ Halted* | Halted | Halted |
| Auto reload | Reset | Functions | Functions | Halted | Functions/ Halted* | Functions/ Halted* | Halted | Halted |
| TMC | Reset | Functions | Retained | Retained | Functions | Retained | Retained | Retained |

Note: *When $\varnothing w/4$ is selected as the TCC internal clock in active mode or sleep mode, since the system clock and internal clock are mutually asynchronous, synchronization is maintained by a synchronization circuit. This results in a maximum count cycle error of $1/\varnothing$ (s). When the counter is operated in subactive mode or subsleep mode, either select $\varnothing w/4$ as the internal clock or select an external clock. The counter will not operate on any other internal clock. If $\varnothing w/4$ is selected as the internal clock for the counter when $\varnothing w/8$ has been selected as subclock \varnothing_{SUB} , the lower 2 bits of the counter operate on the same cycle, and the operation of the least significant bit is unrelated to the operation of the counter.

9.4 Timer F

9.4.1 Overview

Timer F is a 16-bit timer with a built-in output compare function. As well as counting external events, timer F also provides for counter resetting, interrupt request generation, toggle output, etc., using compare match signals. Timer F can also be used as two independent 8-bit timers (timer FH and timer FL).

1. Features

Features of timer F are given below.

- Choice of four internal clock sources ($\phi/32$, $\phi/16$, $\phi/4$, $\phi w/4$) or an external clock (can be used as an external event counter)
- TMOFH pin toggle output provided using a single compare match signal (toggle output initial value can be set)
- Counter resetting by a compare match signal
- Two interrupt sources: one compare match, one overflow
- Can operate as two independent 8-bit timers (timer FH and timer FL) (in 8-bit mode).

| | Timer FH 8-Bit Timer* | Timer FL 8-Bit Timer/Event Counter |
|-------------------|---|--|
| Internal clock | Choice of 4 ($\phi/32$, $\phi/16$, $\phi/4$, $\phi w/4$) | |
| Event input | — | TMIF pin |
| Toggle output | One compare match signal, output to TMOFH pin(initial value settable) | One compare match signal, output to TMOFL pin (initial value settable) |
| Counter reset | Counter can be reset by compare match signal | |
| Interrupt sources | One compare match One overflow | |

Note: * When timer F operates as a 16-bit timer, it operates on the timer FL overflow signal.

- Operation in watch mode, subactive mode, and subsleep mode
When $\phi w/4$ is selected as the internal clock, timer F can operate in watch mode, subactive mode, and subsleep mode.
- Use of module standby mode enables this module to be placed in standby mode independently when not used.

2. Block diagram

Figure 9.3 shows a block diagram of timer F.

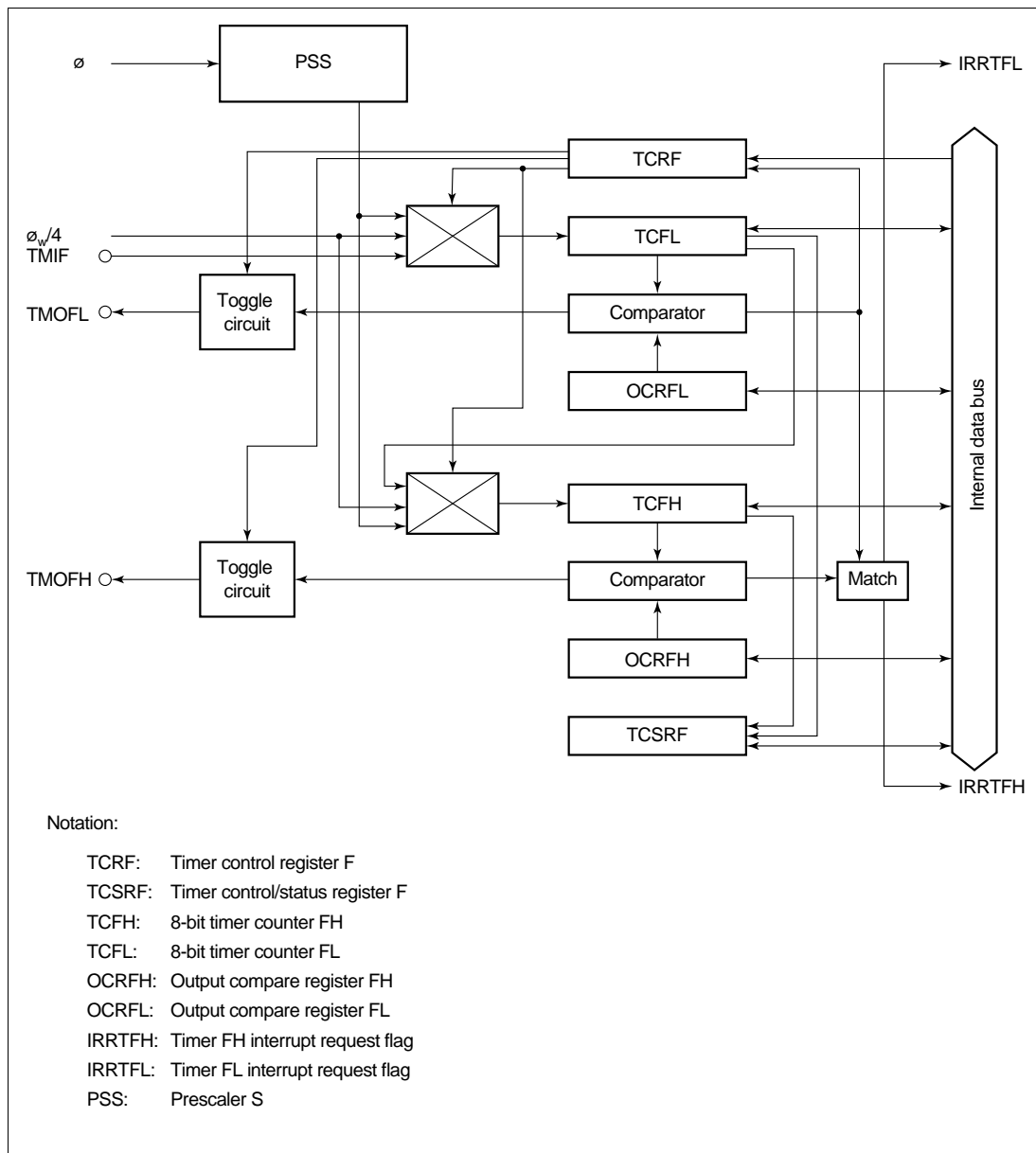

Figure 9.3 Block Diagram of Timer F

3. Pin configuration

Table 9.8 shows the timer F pin configuration.

Table 9.8 Pin Configuration

| Name | Abbrev. | I/O | Function |
|---------------------|----------------|------------|-----------------------------------|
| Timer F event input | TMIF | Input | Event input pin for input to TCFL |
| Timer FH output | TMOFH | Output | Timer FH toggle output pin |
| Timer FL output | TMOFL | Output | Timer FL toggle output pin |

4. Register configuration

Table 9.9 shows the register configuration of timer F.

Table 9.9 Timer F Registers

| Name | Abbrev. | R/W | Initial Value | Address |
|---------------------------------|----------------|------------|----------------------|----------------|
| Timer control register F | TCRF | W | H'00 | H'FFB6 |
| Timer control/status register F | TCSRF | R/W | H'00 | H'FFB7 |
| 8-bit timer counter FH | TCFH | R/W | H'00 | H'FFB8 |
| 8-bit timer counter FL | TCFL | R/W | H'00 | H'FFB9 |
| Output compare register FH | OCRFH | R/W | H'FF | H'FFBA |
| Output compare register FL | OCRFL | R/W | H'FF | H'FFBB |
| Clock stop register 1 | CKSTPR1 | R/W | H'FF | H'FFFA |

9.4.2 Register Descriptions

1. 16-bit timer counter (TCF)
 - 8-bit timer counter (TCFH)
 - 8-bit timer counter (TCFL)

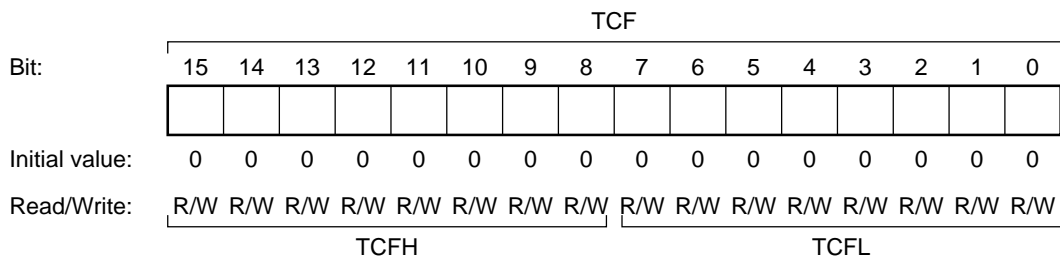

TCF is a 16-bit read/write up-counter configured by cascaded connection of 8-bit timer counters TCFH and TCFL. In addition to the use of TCF as a 16-bit counter with TCFH as the upper 8 bits and TCFL as the lower 8 bits, TCFH and TCFL can also be used as independent 8-bit counters.

TCFH and TCFL can be read and written by the CPU, but when they are used in 16-bit mode, data transfer to and from the CPU is performed via a temporary register (TEMP). For details of TEMP, see 9.4.3, CPU Interface.

TCFH and TCFL are each initialized to H'00 upon reset.

a. 16-bit mode (TCF)

When CKSH2 is cleared to 0 in TCRF, TCF operates as a 16-bit counter. The TCF input clock is selected by bits CKSL2 to CKSL0 in TCRF.

TCF can be cleared in the event of a compare match by means of CCLR in TCSR.

When TCF overflows from H'FFFF to H'0000, OVFH is set to 1 in TCSR. If OVIEH in TCSR is 1 at this time, IRRTFH is set to 1 in IRR2, and if IENTFH in IENR2 is 1, an interrupt request is sent to the CPU.

b. 8-bit mode (TCFL/TCFH)

When CKSH2 is set to 1 in TCRF, TCFH and TCFL operate as two independent 8-bit counters. The TCFH (TCFL) input clock is selected by bits CKSH2 to CKSH0 (CKSL2 to CKSL0) in TCRF.

TCFH (TCFL) can be cleared in the event of a compare match by means of CCLR (CCLR) in TCSR.

When TCFH (TCFL) overflows from H'FF to H'00, OVFH (OVFL) is set to 1 in TCSR. If OVIEH (OVIEL) in TCSR is 1 at this time, IRRTFH (IRRTFL) is set to 1 in IRR2, and if IENTFH (IENTFL) in IENR2 is 1, an interrupt request is sent to the CPU.

- 2. 16-bit output compare register (OCRF)
- 8-bit output compare register (OCRFH)
- 8-bit output compare register (OCRFL)

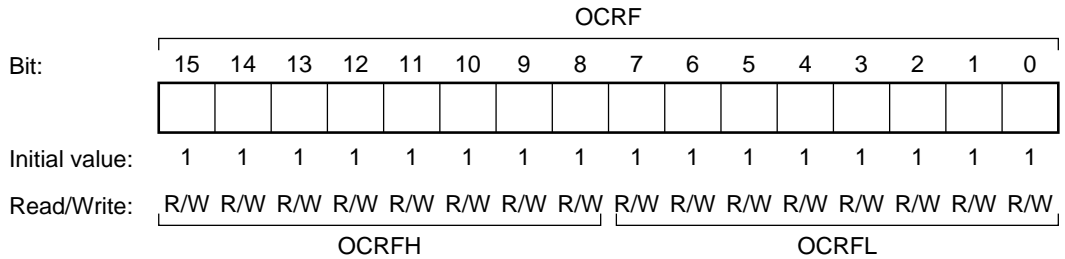

OCRF is a 16-bit read/write register composed of the two registers OCRFH and OCRFL. In addition to the use of OCRF as a 16-bit register with OCRFH as the upper 8 bits and OCRFL as the lower 8 bits, OCRFH and OCRFL can also be used as independent 8-bit registers.

OCRFH and OCRFL can be read and written by the CPU, but when they are used in 16-bit mode, data transfer to and from the CPU is performed via a temporary register (TEMP). For details of TEMP, see 9.4.3, CPU Interface.

OCRFH and OCRFL are each initialized to H'FF upon reset.

a. 16-bit mode (OCRF)

When CKSH2 is cleared to 0 in TCRF, OCRF operates as a 16-bit register. OCRF contents are constantly compared with TCF, and when both values match, CMFH is set to 1 in TCSR. At the same time, IRRTFH is set to 1 in IRR2. If IENTFH in IENR2 is 1 at this time, an interrupt request is sent to the CPU.

Toggle output can be provided from the TMOFH pin by means of compare matches, and the output level can be set (high or low) by means of TOLH in TCRF.

b. 8-bit mode (OCRFH/OCRFL)

When CKSH2 is set to 1 in TCRF, OCRFH and OCRFL operate as two independent 8-bit registers. OCRFH contents are compared with TCFH, and OCRFL contents are with TCFL. When the OCRFH (OCRFL) and TCFH (TCFL) values match, CMFH (CMFL) is set to 1 in TCSR. At the same time, IRRTFH (IRRTFL) is set to 1 in IRR2. If IENTFH (IENTFL) in IENR2 is 1 at this time, an interrupt request is sent to the CPU.

Toggle output can be provided from the TMOFH pin (TMOFL pin) by means of compare matches, and the output level can be set (high or low) by means of TOLH (TOLL) in TCRF.

3. Timer control register F (TCRF)

Bit:

| | 7 | 6 | 5 | 4 | 3 | 2 | 1 | 0 |
|----------------|------|-------|-------|-------|------|-------|-------|-------|
| | TOLH | CKSH2 | CKSH1 | CKSH0 | TOLL | CKSL2 | CKSL1 | CKSL0 |
| Initial value: | 0 | 0 | 0 | 0 | 0 | 0 | 0 | 0 |
| Read/Write: | W | W | W | W | W | W | W | W |

TCRF is an 8-bit write-only register that switches between 16-bit mode and 8-bit mode, selects the input clock from among four internal clock sources or external event input, and sets the output level of the TMOFH and TMOFL pins.

TCRF is initialized to H'00 upon reset.

Bit 7: Toggle output level H (TOLH)

Bit 7 sets the TMOFH pin output level. The output level is effective immediately after this bit is written.

Bit 7

| TOLH | Description |
|------|---------------------------|
| 0 | Low level (initial value) |
| 1 | High level |

Bits 6 to 4: Clock select H (CKSH2 to CKSH0)

Bits 6 to 4 select the clock input to TCFH from among four internal clock sources or TCFL overflow.

| Bit 6 CKSH2 | Bit 5 CKSH1 | Bit 4 CKSH0 | Description |
|----------------|----------------|----------------|---|
| 0 | 0 | 0 | 16-bit mode, counting on TCFL overflow signal (initial value) |
| 0 | 0 | 1 | |
| 0 | 1 | 0 | |
| 0 | 1 | 1 | Use prohibited |
| 1 | 0 | 0 | Internal clock: counting on $\phi/32$ |
| 1 | 0 | 1 | Internal clock: counting on $\phi/16$ |
| 1 | 1 | 0 | Internal clock: counting on $\phi/4$ |
| 1 | 1 | 1 | Internal clock: counting on $\phi w/4$ |

*: Don't care

Bit 3: Toggle output level L (TOLL)

Bit 3 sets the TMOFL pin output level. The output level is effective immediately after this bit is written.

Bit 3

| TOLL | Description | |
|------|-------------|-----------------|
| 0 | Low level | (initial value) |
| 1 | High level | |

Bits 2 to 0: Clock select L (CKSL2 to CKSL0)

Bits 2 to 0 select the clock input to TCFL from among four internal clock sources or external event input.

| Bit 2 CKSL2 | Bit 1 CKSL1 | Bit 0 CKSL0 | Description | |
|----------------|----------------|----------------|---|-----------------|
| 0 | 0 | 0 | Counting on external event (TMIF) rising/ | (initial value) |
| 0 | 0 | 1 | falling edge* | |
| 0 | 1 | 0 | | |
| 0 | 1 | 1 | Use prohibited | |
| 1 | 0 | 0 | Internal clock: counting on $\phi/32$ | |
| 1 | 0 | 1 | Internal clock: counting on $\phi/16$ | |
| 1 | 1 | 0 | Internal clock: counting on $\phi/4$ | |
| 1 | 1 | 1 | Internal clock: counting on $\phi w/4$ | |

Note: * External event edge selection is set by IEG3 in the IRQ edge select register (IEGR). For details, see 1. IRQ edge select register (IEGR) in section 3.3.2.

Note that the timer F counter may increment if the setting of IRQ3 in port mode register 1 (PMR1) is changed from 0 to 1 while the TMIF pin is low in order to change the TMIF pin function.

4. Timer control/status register F (TCSRf)

| | | | | | | | | |
|----------------|------|------|-------|-------|------|------|-------|-------|
| Bit: | 7 | 6 | 5 | 4 | 3 | 2 | 1 | 0 |
| | OVFH | CMFH | OVIEH | CCLRH | OVFL | CMFL | OVIEL | CCLRL |
| Initial value: | 0 | 0 | 0 | 0 | 0 | 0 | 0 | 0 |
| Read/Write: | R/W* | R/W* | R/W | R/W | R/W* | R/W* | R/W | R/W |

Note: * Bits 7, 6, 3, and 2 can only be written with 0, for flag clearing.

TCSRf is an 8-bit read/write register that performs counter clear selection, overflow flag setting, and compare match flag setting, and controls enabling of overflow interrupt requests.

TCSRf is initialized to H'00 upon reset.

Bit 7: Timer overflow flag H (OVFH)

Bit 7 is a status flag indicating that TCFH has overflowed from H'FF to H'00. This flag is set by hardware and cleared by software. It cannot be set by software.

Bit 7

| OVFH | Description |
|------|--|
| 0 | Clearing conditions: After reading OVFH = 1, cleared by writing 0 to OVFH (initial value) |
| 1 | Setting conditions: Set when TCFH overflows from H'FF to H'00 |

Bit 6: Compare match flag H (CMFH)

Bit 6 is a status flag indicating that TCFH has matched OCRFH. This flag is set by hardware and cleared by software. It cannot be set by software.

Bit 6

| CMFH | Description |
|------|--|
| 0 | Clearing conditions: After reading CMFH = 1, cleared by writing 0 to CMFH (initial value) |
| 1 | Setting conditions: Set when the TCFH value matches the OCRFH value |

Bit 5: Timer overflow interrupt enable H (OVIEH)

Bit 5 selects enabling or disabling of interrupt generation when TCFH overflows.

Bit 5

| OVIEH | Description | |
|--------------|---|-----------------|
| 0 | TCFH overflow interrupt request is disabled | (initial value) |
| 1 | TCFH overflow interrupt request is enabled | |

Bit 4: Counter clear H (CCLRH)

In 8-bit mode, bit 4 selects whether TCF is cleared when TCF and OCRF match.

In 8-bit mode, bit 4 selects whether TCFH is cleared when TCFH and OCRFH match.

Bit 4

| CCLRH | Description | |
|--------------|--|-----------------|
| 0 | 16-bit mode: TCF clearing by compare match is disabled 8-bit mode: TCFH clearing by compare match is disabled | (initial value) |
| 1 | 16-bit mode: TCF clearing by compare match is enabled 8-bit mode: TCFH clearing by compare match is enabled | |

Bit 3: Timer overflow flag L (OVFL)

Bit 3 is a status flag indicating that TCFL has overflowed from H'FF to H'00. This flag is set by hardware and cleared by software. It cannot be set by software.

Bit 3

| OVFL | Description | |
|-------------|--|-----------------|
| 0 | Clearing conditions: After reading OVFL = 1, cleared by writing 0 to OVFL | (initial value) |
| 1 | Setting conditions: Set when TCFL overflows from H'FF to H'00 | |

Bit 2: Compare match flag L (CMFL)

Bit 2 is a status flag indicating that TCFL has matched OCRFL. This flag is set by hardware and cleared by software. It cannot be set by software.

Bit 2

| CMFL | Description | |
|-------------|--|-----------------|
| 0 | Clearing conditions: After reading CMFL = 1, cleared by writing 0 to CMFL | (initial value) |
| 1 | Setting conditions: Set when the TCFL value matches the OCRFL value | |

Bit 1: Timer overflow interrupt enable L (OVIEL)

Bit 1 selects enabling or disabling of interrupt generation when TCFL overflows.

Bit 1

| OVIEL | Description | |
|--------------|---|-----------------|
| 0 | TCFL overflow interrupt request is disabled | (initial value) |
| 1 | TCFL overflow interrupt request is enabled | |

Bit 0: Counter clear L (CCLRL)

Bit 0 selects whether TCFL is cleared when TCFL and OCRFL match.

Bit 0

| CCLRL | Description | |
|--------------|--|-----------------|
| 0 | TCFL clearing by compare match is disabled | (initial value) |
| 1 | TCFL clearing by compare match is enabled | |

5. Clock stop register 1 (CKSTPR1)

| | | | | | | | | |
|----------------|-----|----------|----------|---------|---------|---------|----------|---------|
| Bit: | 7 | 6 | 5 | 4 | 3 | 2 | 1 | 0 |
| | — | S31CKSTP | S32CKSTP | ADCKSTP | TGCKSTP | TFCKSTP | TCKCKSTP | TACKSTP |
| Initial value: | 1 | 1 | 1 | 1 | 1 | 1 | 1 | 1 |
| Read/Write: | R/W | R/W | R/W | R/W | R/W | R/W | R/W | R/W |

CKSTPR1 is an 8-bit read/write register that performs module standby mode control for peripheral modules. Only the bit relating to timer F is described here. For details of the other bits, see the sections on the relevant modules.

Bit 2: Timer F module standby mode control (TFCKSTP)

Bit 2 controls setting and clearing of module standby mode for timer F.

| TFCKSTP | Description |
|---------|--|
| 0 | Timer F is set to module standby mode |
| 1 | Timer F module standby mode is cleared (initial value) |

9.4.3 CPU Interface

TCF and OCRF are 16-bit read/write registers, but the CPU is connected to the on-chip peripheral modules by an 8-bit data bus. When the CPU accesses these registers, it therefore uses an 8-bit temporary register (TEMP).

In 16-bit mode, TCF read/write access and OCRF write access must be performed 16 bits at a time (using two consecutive byte-size MOV instructions), and the upper byte must be accessed before the lower byte. Data will not be transferred correctly if only the upper byte or only the lower byte is accessed.

In 8-bit mode, there are no restrictions on the order of access.

1. Write access

Write access to the upper byte results in transfer of the upper-byte write data to TEMP. Next, write access to the lower byte results in transfer of the data in TEMP to the upper register byte, and direct transfer of the lower-byte write data to the lower register byte.

Figure 9.4 shows an example in which H'AA55 is written to TCF.

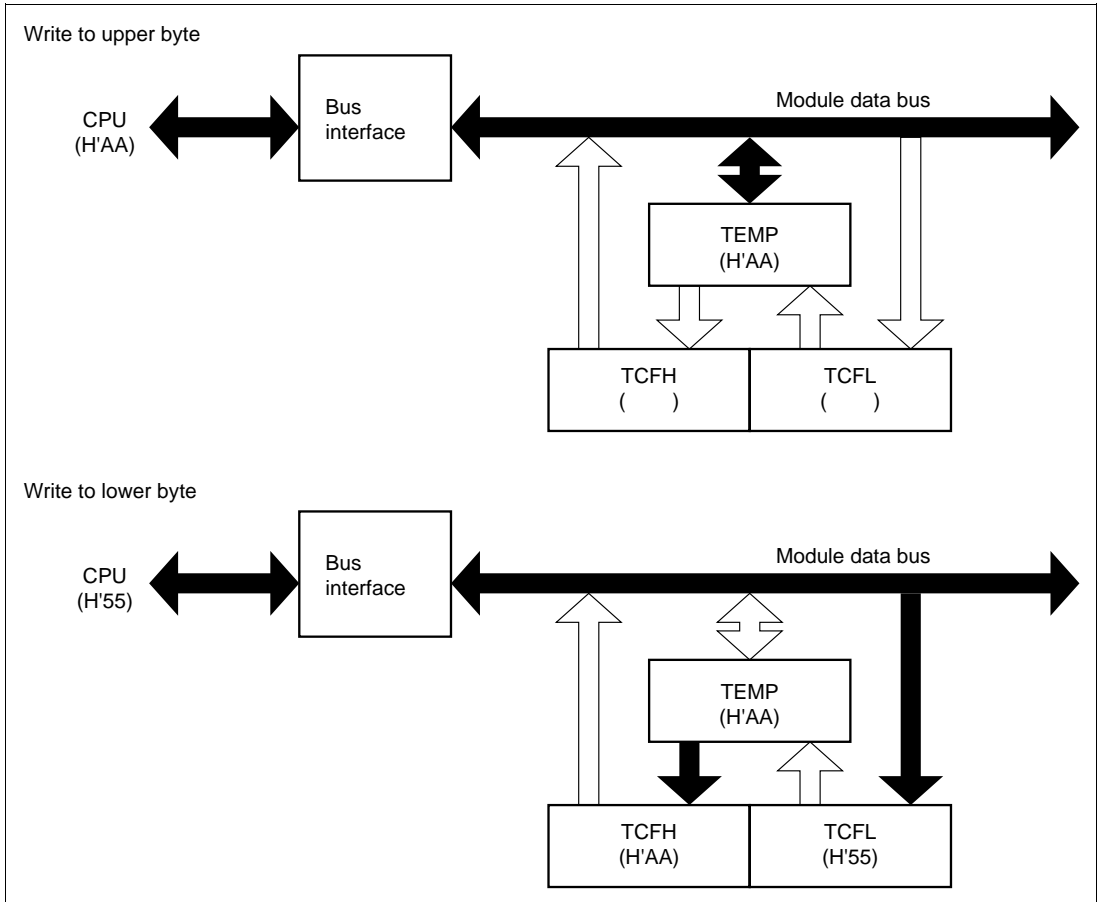

Figure 9.4 Write Access to TCF (CPU \neq TCF)

2. Read access

In access to TCF, when the upper byte is read the upper-byte data is transferred directly to the CPU and the lower-byte data is transferred to TEMP. Next, when the lower byte is read, the lower-byte data in TEMP is transferred to the CPU.

In access to OCRF, when the upper byte is read the upper-byte data is transferred directly to the CPU. When the lower byte is read, the lower-byte data is transferred directly to the CPU.

Figure 9.5 shows an example in which TCF is read when it contains H'A AFF.

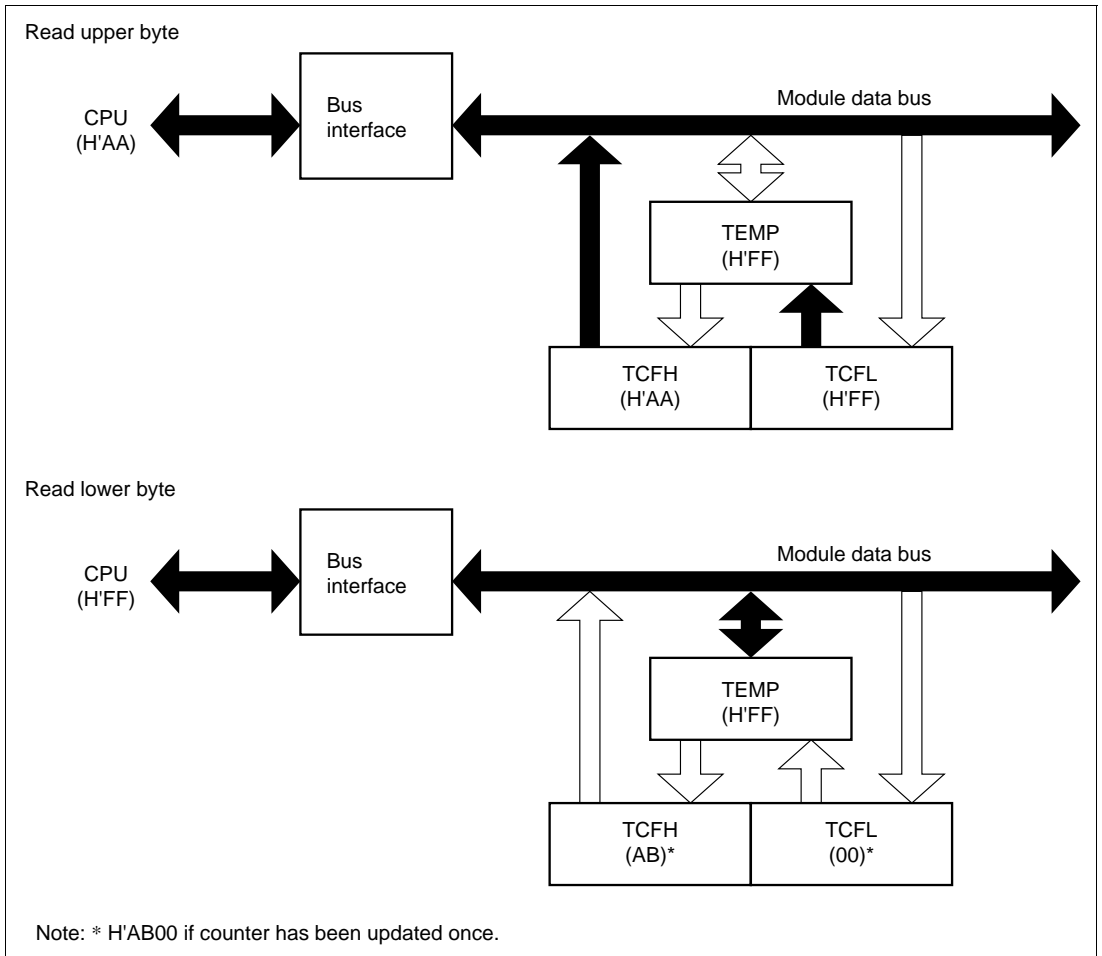

Figure 9.5 Read Access to TCF (TCF Æ CPU)

9.4.4 Operation

Timer F is a 16-bit counter that increments on each input clock pulse. The timer F value is constantly compared with the value set in output compare register F, and the counter can be cleared, an interrupt requested, or port output toggled, when the two values match. Timer F can also function as two independent 8-bit timers.

1. Timer F operation

Timer F has two operating modes, 16-bit timer mode and 8-bit timer mode. The operation in each of these modes is described below.

a. Operation in 16-bit timer mode

When CKSH2 is cleared to 0 in timer control register F (TCRF), timer F operates as a 16-bit timer.

Following a reset, timer counter F (TCF) is initialized to H'0000, output compare register F (OCRF) to H'FFFF, and timer control register F (TCRF) and timer control/status register F (TCSRf) to H'00. The counter starts incrementing on external event (TMIF) input. The external event edge selection is set by IEG3 in the IRQ edge select register (IEGR).

The timer F operating clock can be selected from four internal clocks output by prescaler S or an external clock by means of bits CKSL2 to CKSL0 in TCRF.

OCRF contents are constantly compared with TCF, and when both values match, CMFH is set to 1 in TCSRf. If IENTFH in IENR2 is 1 at this time, an interrupt request is sent to the CPU, and at the same time, TMOFH pin output is toggled. If CCLRf in TCSRf is 1, TCF is cleared. TMOFH pin output can also be set by TOLH in TCRF.

When TCF overflows from H'FFFF to H'0000, OVfH is set to 1 in TCSRf. If OVIEH in TCSRf and IENTFH in IENR2 are both 1, an interrupt request is sent to the CPU.

b. Operation in 8-bit timer mode

When CKSH2 is set to 1 in TCRF, TCF operates as two independent 8-bit timers, TCFH and TCFL. The TCFH/TCFL input clock is selected by CKSH2 to CKSH0/CKSL2 to CKSL0 in TCRF.

When the OCRFH/OCRFL and TCFH/TCFL values match, CMFH/CMFL is set to 1 in TCSRf. If IENTFH/IENTFL in IENR2 is 1, an interrupt request is sent to the CPU, and at the same time, TMOFH pin/TMOFL pin output is toggled. If CCLRf/CCLRL in TCSRf is 1, TCFH/TCFL is cleared. TMOFH pin/TMOFL pin output can also be set by TOLH/TOLL in TCRF.

When TCFH/TCFL overflows from H'FF to H'00, OVfH/OVfL is set to 1 in TCSRf. If OVIEH/OVIEL in TCSRf and IENTFH/IENTFL in IENR2 are both 1, an interrupt request is sent to the CPU.

2. TCF increment timing

TCF is incremented by clock input (internal clock or external event input).

a. Internal clock operation

Bits CKSH2 to CKSH0 or CKSL2 to CKSL0 in TCRF select one of four internal clock sources ($\phi/32$, $\phi/16$, $\phi/4$, or $\phi w/4$) created by dividing the system clock (ϕ or ϕw).

b. External event operation

External event input is selected by clearing CKSL2 to 0 in TCRF. TCF can increment on either the rising or falling edge of external event input. External event edge selection is set by IEG3 in the interrupt controller's IEGR register. An external event pulse width of at least 2 system clocks (ϕ) is necessary. Shorter pulses will not be counted correctly.

3. TMOFH/TMOFL output timing

In TMOFH/TMOFL output, the value set in TOLH/TOLL in TCRF is output. The output is toggled by the occurrence of a compare match. Figure 9.6 shows the output timing.

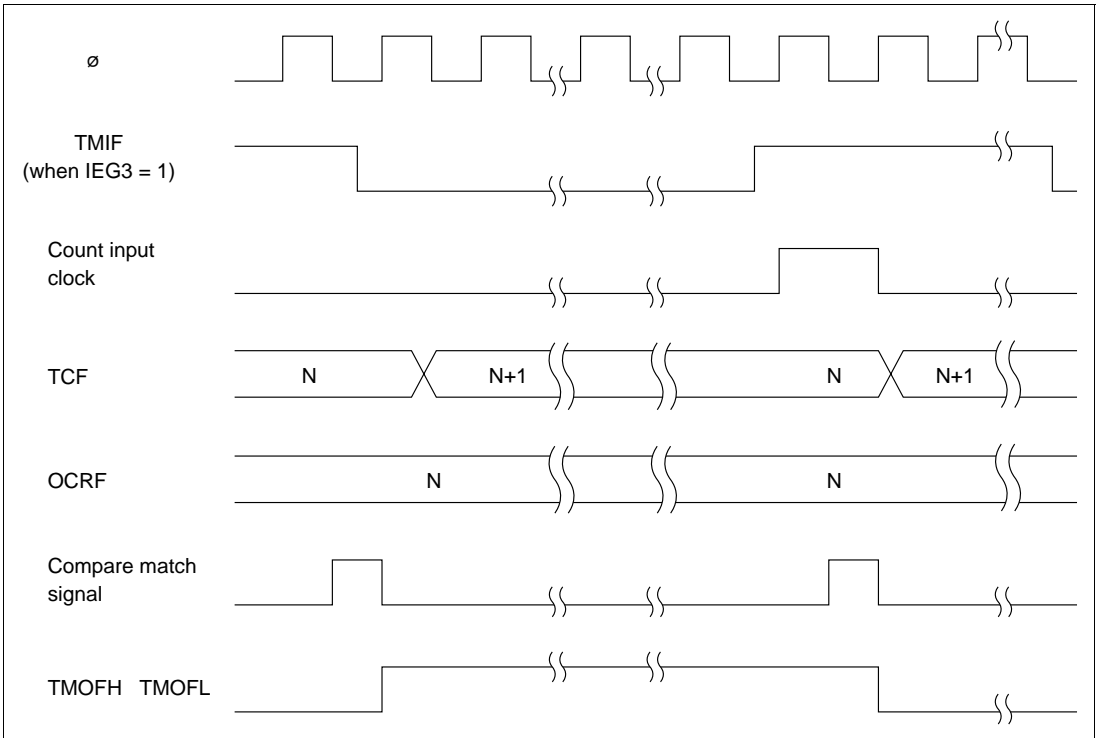

Figure 9.6 TMOFH/TMOFL Output Timing

4. TCF clear timing

TCF can be cleared by a compare match with OCRF.

5. Timer overflow flag (OVF) set timing

OVF is set to 1 when TCF overflows from H'FFFF to H'0000.

6. Compare match flag set timing

The compare match flag (CMFH or CMFL) is set to 1 when the TCF and OCRF values match. The compare match signal is generated in the last state during which the values match (when TCF is updated from the matching value to a new value). When TCF matches OCRF, the compare match signal is not generated until the next counter clock.

7. Timer F operation modes

Timer F operation modes are shown in table 9.10.

Table 9.10 Timer F Operation Modes

| Operation Mode | Reset | Active | Sleep | Watch | Sub-active | Sub-sleep | Standby | Module Standby |
|----------------|-------|-----------|-----------|-----------------------|-----------------------|-----------------------|---------|----------------|
| TCF | Reset | Functions | Functions | Functions/ Halted* | Functions/ Halted* | Functions/ Halted* | Halted | Halted |
| OCRF | Reset | Functions | Held | Held | Functions | Held | Held | Held |
| TCRF | Reset | Functions | Held | Held | Functions | Held | Held | Held |
| TCSRf | Reset | Functions | Held | Held | Functions | Held | Held | Held |

Note: *When $\phi_w/4$ is selected as the TCF internal clock in active mode or sleep mode, since the system clock and internal clock are mutually asynchronous, synchronization is maintained by a synchronization circuit. This results in a maximum count cycle error of $1/\phi$ (s). When the counter is operated in subactive mode, watch mode, or subsleep mode, $\phi_w/4$ must be selected as the internal clock. The counter will not operate if any other internal clock is selected.

9.4.5 Application Notes

The following types of contention and operation can occur when timer F is used.

1. 16-bit timer mode

In toggle output, TMOFH pin output is toggled when all 16 bits match and a compare match signal is generated. If a TCRF write by a MOV instruction and generation of the compare match signal occur simultaneously, TOLH data is output to the TMOFH pin as a result of the TCRF write. TMOFL pin output is unstable in 16-bit mode, and should not be used; the TMOFL pin should be used as a port pin.

If an OCRFL write and compare match signal generation occur simultaneously, the compare match signal is invalid. However, if the written data and the counter value match, a compare match signal will be generated at that point. As the compare match signal is output in synchronization with the TCFL clock, a compare match will not result in compare match signal generation if the clock is stopped.

Compare match flag CMFH is set when all 16 bits match and a compare match signal is generated. Compare match flag CMFL is set if the setting conditions for the lower 8 bits are satisfied.

When TCF overflows, OVFH is set. OVFL is set if the setting conditions are satisfied when the lower 8 bits overflow. If a TCFL write and overflow signal output occur simultaneously, the overflow signal is not output.

2. 8-bit timer mode

a. TCFH, OCRFH

In toggle output, TMOFH pin output is toggled when a compare match occurs. If a TCRF write by a MOV instruction and generation of the compare match signal occur simultaneously, TOLH data is output to the TMOFH pin as a result of the TCRF write.

If an OCRFH write and compare match signal generation occur simultaneously, the compare match signal is invalid. However, if the written data and the counter value match, a compare match signal will be generated at that point. The compare match signal is output in synchronization with the TCFH clock.

If a TCFH write and overflow signal output occur simultaneously, the overflow signal is not output.

b. TCFL, OCRFL

In toggle output, TMOFL pin output is toggled when a compare match occurs. If a TCRF write by a MOV instruction and generation of the compare match signal occur simultaneously, TOLL data is output to the TMOFL pin as a result of the TCRF write.

If an OCRFL write and compare match signal generation occur simultaneously, the compare match signal is invalid. However, if the written data and the counter value match, a compare match signal will be generated at that point. As the compare match signal is output in synchronization with the TCFL clock, a compare match will not result in compare match signal generation if the clock is stopped.

If a TCFL write and overflow signal output occur simultaneously, the overflow signal is not output.

9.5 Timer G

9.5.1 Overview

Timer G is an 8-bit timer with dedicated input capture functions for the rising/falling edges of pulses input from the input capture input pin (input capture input signal). High-frequency component noise in the input capture input signal can be eliminated by a noise canceler, enabling accurate measurement of the input capture input signal duty cycle. If input capture input is not set, timer G functions as an 8-bit interval timer.

1. Features

Features of timer G are given below.

- Choice of four internal clock sources ($\phi/64$, $\phi/32$, $\phi/2$, $\phi w/2$)
- Dedicated input capture functions for rising and falling edges
- Level detection at counter overflow

It is possible to detect whether overflow occurred when the input capture input signal was high or when it was low.

- Selection of whether or not the counter value is to be cleared at the input capture input signal rising edge, falling edge, or both edges
- Two interrupt sources: one input capture, one overflow. The input capture input signal rising or falling edge can be selected as the interrupt source.
- A built-in noise canceler eliminates high-frequency component noise in the input capture input signal.
- Watch mode, subactive mode and subsleep mode operation is possible when $\phi w/2$ is selected as the internal clock.
- Use of module standby mode enables this module to be placed in standby mode independently when not used.

2. Block diagram

Figure 9.7 shows a block diagram of timer G.

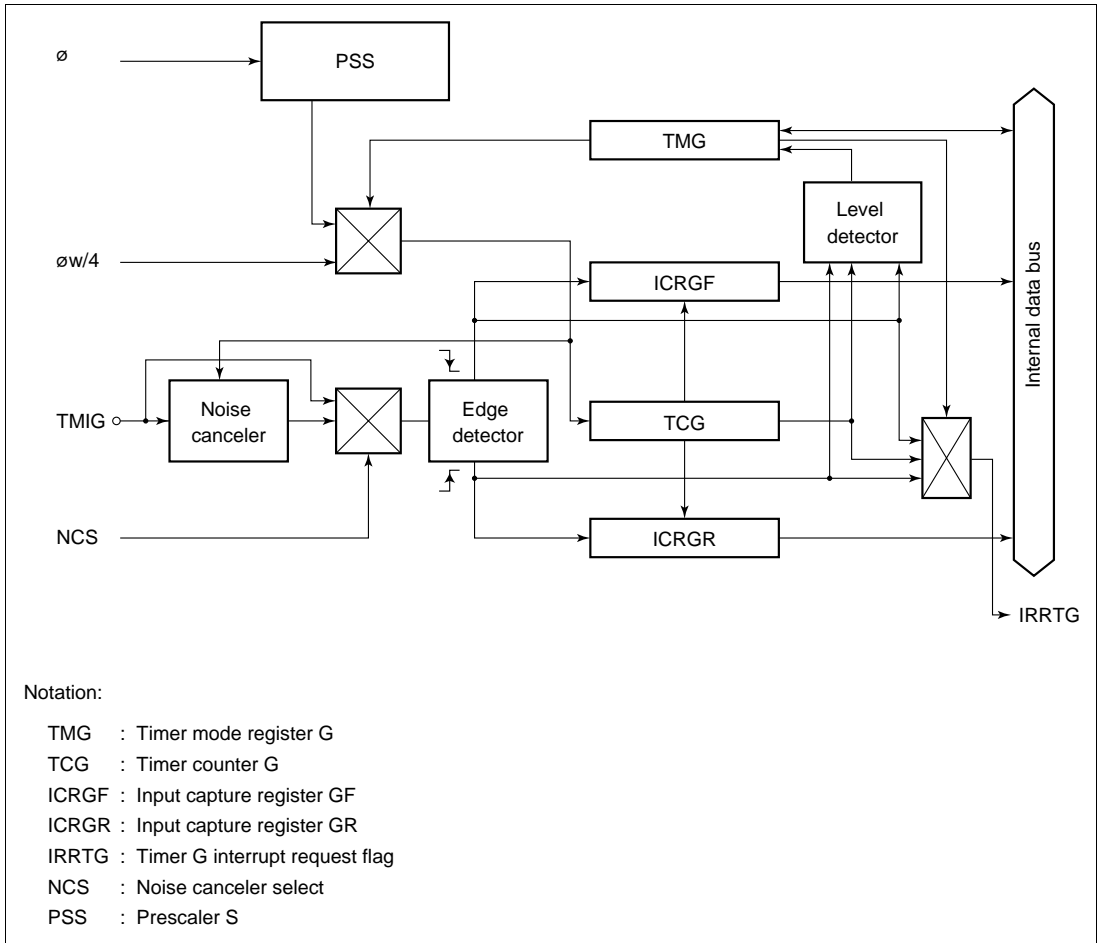

Figure 9.7 Block Diagram of Timer G

3. Pin configuration

Table 9.11 shows the timer G pin configuration.

Table 9.11 Pin Configuration

| Name | Abbrev. | I/O | Function |
|---------------------|----------------|------------|-------------------------|
| Input capture input | TMIG | Input | Input capture input pin |

4. Register configuration

Table 9.12 shows the register configuration of timer G.

Table 9.12 Timer G Registers

| Name | Abbrev. | R/W | Initial Value | Address |
|---------------------------|----------------|------------|----------------------|----------------|
| Timer control register G | TMG | R/W | H'00 | H'FFBC |
| Timer counter G | TCG | — | H'00 | — |
| Input capture register GF | ICRGF | R | H'00 | H'FFBD |
| Input capture register GR | ICRGR | R | H'00 | H'FFBE |
| Clock stop register 1 | CKSTPR1 | R/W | H'FF | H'FFFA |

9.5.2 Register Descriptions

1. Timer counter (TCG)

| | | | | | | | | |
|----------------|------|------|------|------|------|------|------|------|
| Bit: | 7 | 6 | 5 | 4 | 3 | 2 | 1 | 0 |
| | TCG7 | TCG6 | TCG5 | TCG4 | TCG3 | TCG2 | TCG1 | TCG0 |
| Initial value: | 0 | 0 | 0 | 0 | 0 | 0 | 0 | 0 |
| Read/Write: | — | — | — | — | — | — | — | — |

TCG is an 8-bit up-counter which is incremented by clock input. The input clock is selected by bits CKS1 and CKS0 in TMG.

TMIG in PMR1 is set to 1 to operate TCG as an input capture timer, or cleared to 0 to operate TCG as an interval timer*. In input capture timer operation, the TCG value can be cleared by the rising edge, falling edge, or both edges of the input capture input signal, according to the setting made in TMG.

When TCG overflows from H'FF to H'00, if OVIE in TMG is 1, IRRTG is set to 1 in IRR2, and if IENTG in IENR2 is 1, an interrupt request is sent to the CPU.

For details of the interrupt, see 3.3, Interrupts.

TCG cannot be read or written by the CPU. It is initialized to H'00 upon reset.

Note: * An input capture signal may be generated when TMIG is modified.

2. Input capture register GF (ICRGF)

| | | | | | | | | |
|----------------|--------|--------|--------|--------|--------|--------|--------|--------|
| Bit: | 7 | 6 | 5 | 4 | 3 | 2 | 1 | 0 |
| | ICRGF7 | ICRGF6 | ICRGF5 | ICRGF4 | ICRGF3 | ICRGF2 | ICRGF1 | ICRGF0 |
| Initial value: | 0 | 0 | 0 | 0 | 0 | 0 | 0 | 0 |
| Read/Write: | R | R | R | R | R | R | R | R |

ICRGF is an 8-bit read-only register. When a falling edge of the input capture input signal is detected, the current TCG value is transferred to ICRGF. If IIEGS in TMG is 1 at this time, IRRTG is set to 1 in IRR2, and if IENTG in IENR2 is 1, an interrupt request is sent to the CPU.

For details of the interrupt, see 3.3, Interrupts.

To ensure dependable input capture operation, the pulse width of the input capture input signal must be at least 2ϕ or $2\phi_{SUB}$ (when the noise canceler is not used).

ICRGF is initialized to H'00 upon reset.

3. Input capture register GR (ICRGR)

| | | | | | | | | |
|----------------|--------|--------|--------|--------|--------|--------|--------|--------|
| Bit: | 7 | 6 | 5 | 4 | 3 | 2 | 1 | 0 |
| | ICRGR7 | ICRGR6 | ICRGR5 | ICRGR4 | ICRGR3 | ICRGR2 | ICRGR1 | ICRGR0 |
| Initial value: | 0 | 0 | 0 | 0 | 0 | 0 | 0 | 0 |
| Read/Write: | R | R | R | R | R | R | R | R |

ICRGR is an 8-bit read-only register. When a rising edge of the input capture input signal is detected, the current TCG value is transferred to ICRGR. If IIEGS in TMG is 1 at this time, IRR2G is set to 1 in IRR2, and if IENTG in IENR2 is 1, an interrupt request is sent to the CPU.

For details of the interrupt, see 3.3, Interrupts.

To ensure dependable input capture operation, the pulse width of the input capture input signal must be at least 2ϕ or $2\phi_{SUB}$ (when the noise canceler is not used).

ICRGR is initialized to H'00 upon reset.

4. Timer mode register G (TMG)

| | | | | | | | | |
|----------------|------|------|------|-------|-------|-------|------|------|
| Bit: | 7 | 6 | 5 | 4 | 3 | 2 | 1 | 0 |
| | OVFH | OVFL | OVIE | IIEGS | CCLR1 | CCLR0 | CKS1 | CKS0 |
| Initial value: | 0 | 0 | 0 | 0 | 0 | 0 | 0 | 0 |
| Read/Write: | R/W* | R/W* | R/W | R/W | R/W | R/W | R/W | R/W |

Note: * Bits 7 and 6 can only be written with 0, for flag clearing.

TMG is an 8-bit read/write register that performs TCG clock selection from four internal clock sources, counter clear selection, and edge selection for the input capture input signal interrupt request, controls enabling of overflow interrupt requests, and also contains the overflow flags.

TMG is initialized to H'00 upon reset.

Bit 7: Timer overflow flag H (OVFH)

Bit 7 is a status flag indicating that TCG has overflowed from H'FF to H'00 when the input capture input signal is high. This flag is set by hardware and cleared by software. It cannot be set by software.

Bit 7

OVFH

Description

| | Description | |
|---|--|-----------------|
| 0 | Clearing conditions: After reading OVFH = 1, cleared by writing 0 to OVFH | (initial value) |
| 1 | Setting conditions: Set when TCG overflows from H'FF to H'00 | |

Bit 6: Timer overflow flag L (OVFL)

Bit 6 is a status flag indicating that TCG has overflowed from H'FF to H'00 when the input capture input signal is low, or in interval operation. This flag is set by hardware and cleared by software. It cannot be set by software.

Bit 6

OVFL

Description

| | Description | |
|---|--|-----------------|
| 0 | Clearing conditions: After reading OVFL = 1, cleared by writing 0 to OVFL | (initial value) |
| 1 | Setting conditions: Set when TCG overflows from H'FF to H'00 | |

Bit 5: Timer overflow interrupt enable (OVIE)

Bit 5 selects enabling or disabling of interrupt generation when TCG overflows.

Bit 5

OVIE

Description

| | | |
|---|--|-----------------|
| 0 | TCG overflow interrupt request is disabled | (initial value) |
| 1 | TCG overflow interrupt request is enabled | |

Bit 4: Input capture interrupt edge select (IIEGS)

Bit 4 selects the input capture input signal edge that generates an interrupt request.

Bit 4

| IIEGS | Description |
|-------|--|
| 0 | Interrupt generated on rising edge of input capture input signal (initial value) |
| 1 | Interrupt generated on falling edge of input capture input signal |

Bits 3 and 2: Counter clear 1 and 0 (CCLR1, CCLR0)

Bits 3 and 2 specify whether or not TCG is cleared by the rising edge, falling edge, or both edges of the input capture input signal.

Bit 3**Bit 2**

| CCLR1 | CCLR0 | Description |
|-------|-------|---|
| 0 | 0 | TCG clearing is disabled (initial value) |
| 0 | 1 | TCG cleared by falling edge of input capture input signal |
| 1 | 0 | TCG cleared by rising edge of input capture input signal |
| 1 | 1 | TCG cleared by both edges of input capture input signal |

Bits 1 and 0: Clock select (CKS1, CKS0)

Bits 1 and 0 select the clock input to TCG from among four internal clock sources.

Bit 1
CKS1**Bit 0**
CKS0**Description**

| CKS1 | CKS0 | Description |
|------|------|---|
| 0 | 0 | Internal clock: counting on $\phi/64$ (initial value) |
| 0 | 1 | Internal clock: counting on $\phi/32$ |
| 1 | 0 | Internal clock: counting on $\phi/2$ |
| 1 | 1 | Internal clock: counting on $\phi w/4$ |

5. Clock stop register 1 (CKSTPR1)

| | | | | | | | | |
|----------------|-----|----------|----------|---------|---------|---------|--------|---------|
| Bit: | 7 | 6 | 5 | 4 | 3 | 2 | 1 | 0 |
| | — | S31CKSTP | S32CKSTP | ADCKSTP | TGCKSTP | TFCKSTP | TCKSTP | TACKSTP |
| Initial value: | 1 | 1 | 1 | 1 | 1 | 1 | 1 | 1 |
| Read/Write: | R/W | R/W | R/W | R/W | R/W | R/W | R/W | R/W |

CKSTPR1 is an 8-bit read/write register that performs module standby mode control for peripheral modules. Only the bit relating to timer G is described here. For details of the other bits, see the sections on the relevant modules.

Bit 3: Timer G module standby mode control (TGCKSTP)

Bit 3 controls setting and clearing of module standby mode for timer G.

| TGCKSTP | Description |
|---------|--|
| 0 | Timer G is set to module standby mode |
| 1 | Timer G module standby mode is cleared (initial value) |

9.5.3 Noise Canceler

The noise canceler consists of a digital low-pass filter that eliminates high-frequency component noise from the pulses input from the input capture input pin. The noise canceler is set by NCS* in PMR3.

Figure 9.8 shows a block diagram of the noise canceler.

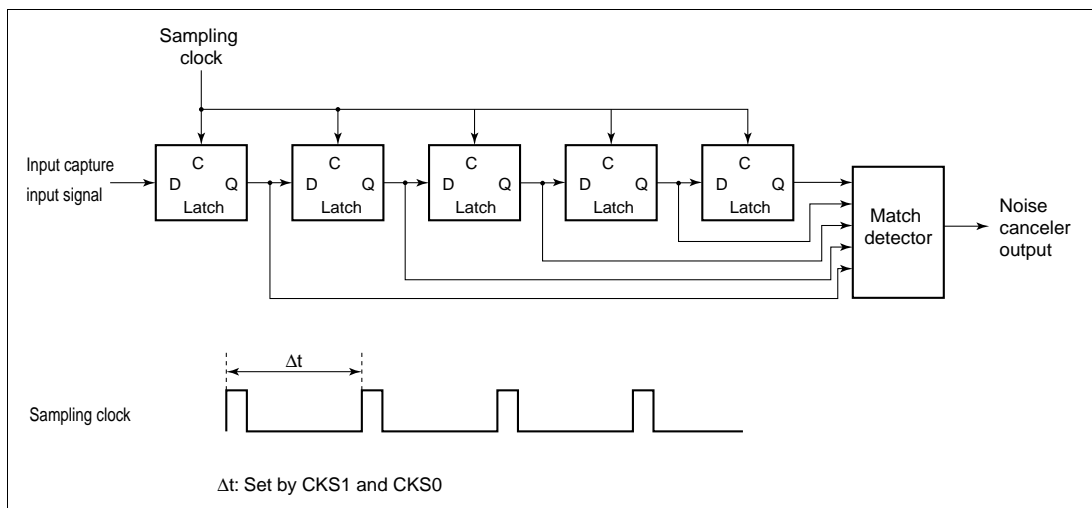

Figure 9.8 Noise Canceler Block Diagram

The noise canceler consists of five latch circuits connected in series and a match detector circuit. When the noise cancellation function is not used (NCS = 0), the system clock is selected as the sampling clock. When the noise cancellation function is used (NCS = 1), the sampling clock is the internal clock selected by CKS1 and CKS0 in TMG, the input capture input is sampled on the rising edge of this clock, and the data is judged to be correct when all the latch outputs match. If all the outputs do not match, the previous value is retained. After a reset, the noise canceler output is initialized when the falling edge of the input capture input signal has been sampled five times. Therefore, after making a setting for use of the noise cancellation function, a pulse with at least five times the width of the sampling clock is a dependable input capture signal. Even if noise cancellation is not used, an input capture input signal pulse width of at least 2ϕ or $2\phi_{SUB}$ is necessary to ensure that input capture operations are performed properly.

Note: * An input capture signal may be generated when the NCS bit is modified.

Figure 9.9 shows an example of noise canceler timing.

In this example, high-level input of less than five times the width of the sampling clock at the input capture input pin is eliminated as noise.

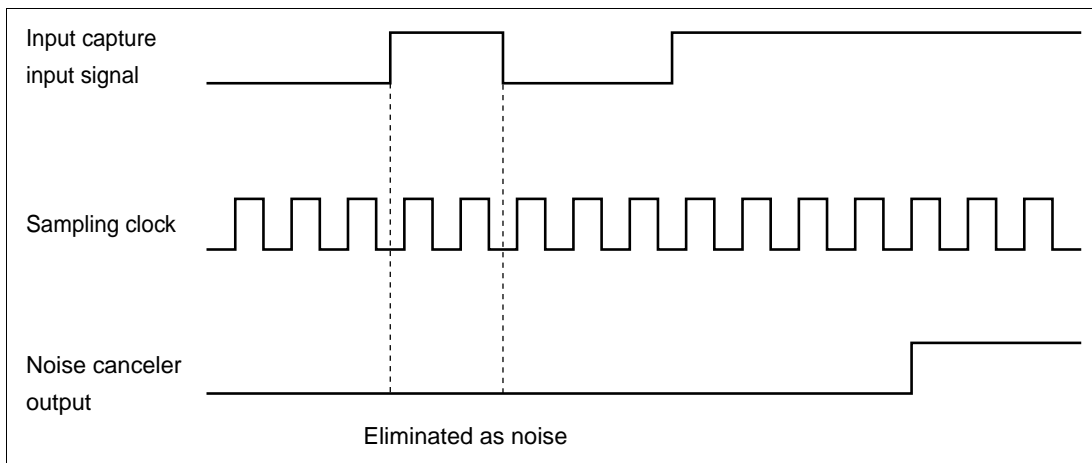

Figure 9.9 Noise Canceler Timing (Example)

9.5.4 Operation

Timer G is an 8-bit timer with built-in input capture and interval functions.

1. Timer G functions

Timer G is an 8-bit up-counter with two functions, an input capture timer function and an interval timer function.

The operation of these two functions is described below.

a. Input capture timer operation

When the TMIG bit is set to 1 in port mode register 1 (PMR1), timer G functions as an input capture timer*.

In a reset, timer mode register G (TMG), timer counter G (TCG), input capture register GF (ICRGF), and input capture register GR (ICRGR) are all initialized to H'00.

Following a reset, TCG starts incrementing on the $\phi/64$ internal clock.

The input clock can be selected from four internal clock sources by bits CKS1 and CKS0 in TMG.

When a rising edge/falling edge is detected in the input capture signal input from the TMIG pin, the TCG value at that time is transferred to ICRGR/ICRGF. When the edge selected by IIEGS in TMG is input, IRRTG is set to 1 in IRR2, and if the IENTG bit in IENR2 is 1 at this time, an interrupt request is sent to the CPU. For details of the interrupt, see 3.3., Interrupts.

TCG can be cleared by a rising edge, falling edge, or both edges of the input capture signal, according to the setting of bits CCLR1 and CCLR0 in TMG. If TCG overflows when the input capture signal is high, the OVFH bit is set in TMG; if TCG overflows when the input capture signal is low, the OVFL bit is set in TMG. If the OVIE bit in TMG is 1 when these bits are set, IRRTG is set to 1 in IRR2, and if the IENTG bit in IENR2 is 1, timer G sends an interrupt request to the CPU. For details of the interrupt, see 3.3., Interrupts.

Timer G has a built-in noise canceler that enables high-frequency component noise to be eliminated from pulses input from the TMIG pin. For details, see 9.5.3, Noise Canceler.

Note: * An input capture signal may be generated when TMIG is modified.

b. Interval timer operation

When the TMIG bit is cleared to 0 in PMR1, timer G functions as an interval timer. Following a reset, TCG starts incrementing on the $\phi/64$ internal clock. The input clock can be selected from four internal clock sources by bits CKS1 and CKS0 in TMG. TCG increments on the selected clock, and when it overflows from H'FF to H'00, the OVFL bit is set to 1 in TMG. If the OVIE bit in TMG is 1 at this time, IRRTG is set to 1 in IRR2, and if the IENTG bit in IENR2 is 1, timer G sends an interrupt request to the CPU. For details of the interrupt, see 3.3., Interrupts.

2. Increment timing

TCG is incremented by internal clock input. Bits CKS1 and CKS0 in TMG select one of four internal clock sources ($\phi/64$, $\phi/32$, $\phi/2$, or $\phi w/4$) created by dividing the system clock (ϕ) or watch clock (ϕw).

3. Input capture input timing

a. Without noise cancellation function

For input capture input, dedicated input capture functions are provided for rising and falling edges.

Figure 9.10 shows the timing for rising/falling edge input capture input.

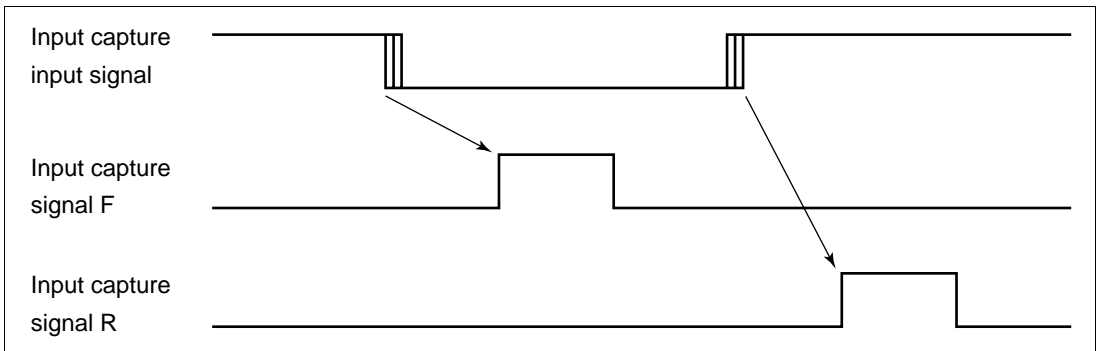

Figure 9.10 Input Capture Input Timing (without Noise Cancellation Function)

b. With noise cancellation function

When noise cancellation is performed on the input capture input, the passage of the input capture signal through the noise canceler results in a delay of five sampling clock cycles from the input capture input signal edge.

Figure 9.11 shows the timing in this case.

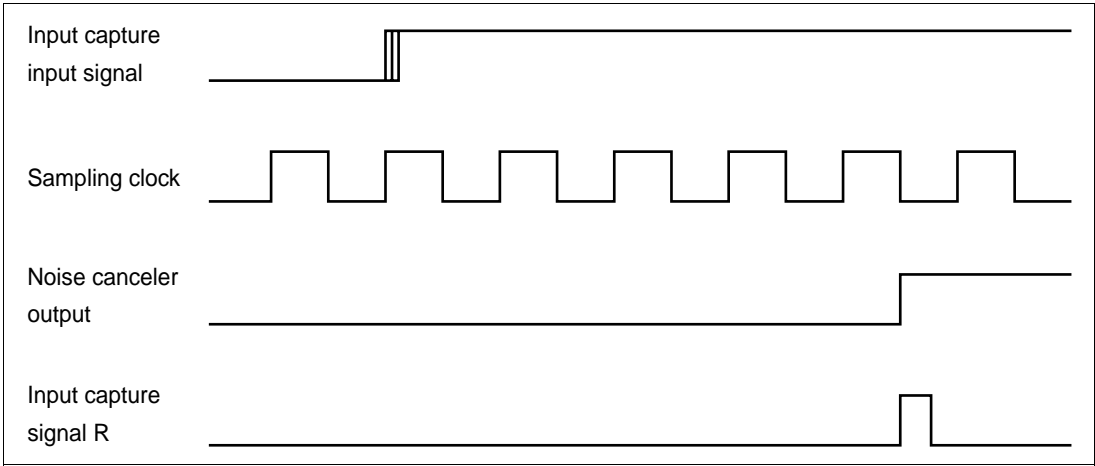

Figure 9.11 Input Capture Input Timing (with Noise Cancellation Function)

4. Timing of input capture by input capture input

Figure 9.12 shows the timing of input capture by input capture input

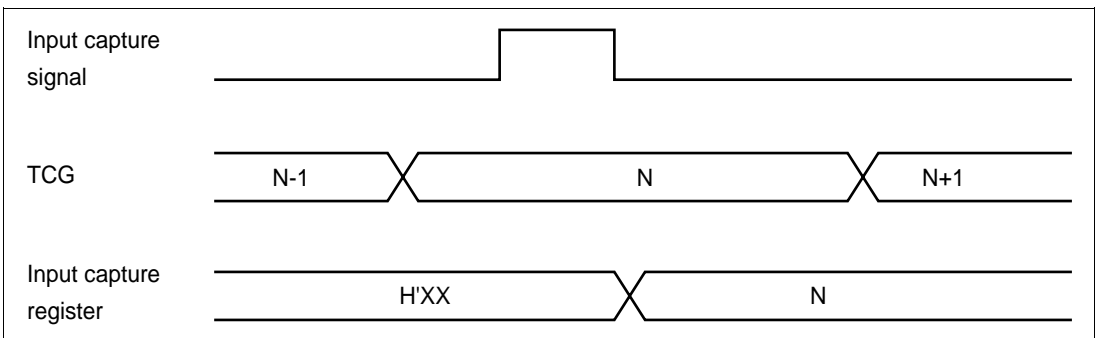

Figure 9.12 Timing of Input Capture by Input Capture Input

5. TGC clear timing

TCG can be cleared by the rising edge, falling edge, or both edges of the input capture input signal.

Figure 9.13 shows the timing for clearing by both edges.

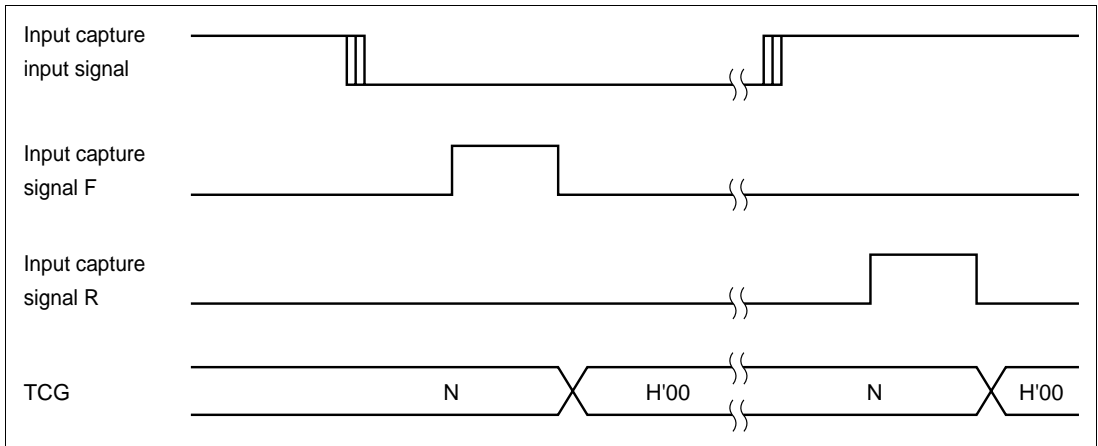

Figure 9.13 TCG Clear Timing

6. Timer G operation modes

Timer G operation modes are shown in table 9.13.

Table 9.13 Timer G Operation Modes

| Operation Mode | Reset | Active | Sleep | Watch | Sub-active | Sub-sleep | Standby | Module Standby |
|-------------------|-------|------------|------------|-----------------------|-----------------------|-----------------------|---------|----------------|
| TCG Input capture | Reset | Functions* | Functions* | Functions/ halted* | Functions/ halted* | Functions/ halted* | Halted | Halted |
| Interval | Reset | Functions* | Functions* | Functions/ halted* | Functions/ halted* | Functions/ halted* | Halted | Halted |
| ICRGF | Reset | Functions* | Functions* | Functions/ halted* | Functions/ halted* | Functions/ halted* | Held | Held |
| ICRGR | Reset | Functions* | Functions* | Functions/ halted* | Functions/ halted* | Functions/ halted* | Held | Held |
| TMG | Reset | Functions | Held | Held | Functions | Held | Held | Held |

Note: * When $\phi w/4$ is selected as the TCG internal clock in active mode or sleep mode, since the system clock and internal clock are mutually asynchronous, synchronization is maintained by a synchronization circuit. This results in a maximum count cycle error of $1/\phi$ (s). When $\phi w/4$ is selected as the TCG internal clock in watch mode, TCG and the noise canceler operate on the $\phi w/4$ internal clock without regard to the ϕ_{SUB} subclock ($\phi w/8$, $\phi w/4$, $\phi w/2$). Note that when another internal clock is selected, TCG and the noise canceler do not operate, and input of the input capture input signal does not result in input capture.

To be operated Timer G in subactive mode or subsleep mode, select $\phi w/4$ for internal clock of TCG and also select $\phi w/2$ for sub clock ϕ_{SUB} . When another internal clock is selected and when another sub clock ($\phi w/8$, $\phi w/4$) is selected, TCG and noise canceler do not operate.

9.5.5 Application Notes

1. Internal clock switching and TCG operation

Depending on the timing, TCG may be incremented by a switch between difference internal clock sources. Table 9.14 shows the relation between internal clock switchover timing (by write to bits CKS1 and CKS0) and TCG operation.

When TCG is internally clocked, an increment pulse is generated on detection of the falling edge of an internal clock signal, which is divided from the system clock (ϕ) or subclock (ϕw). For this reason, in a case like No. 3 in table 9.14 where the switch is from a high clock signal to a low clock signal, the switchover is seen as a falling edge, causing TCG to increment.

Table 9.14 Internal Clock Switching and TCG Operation

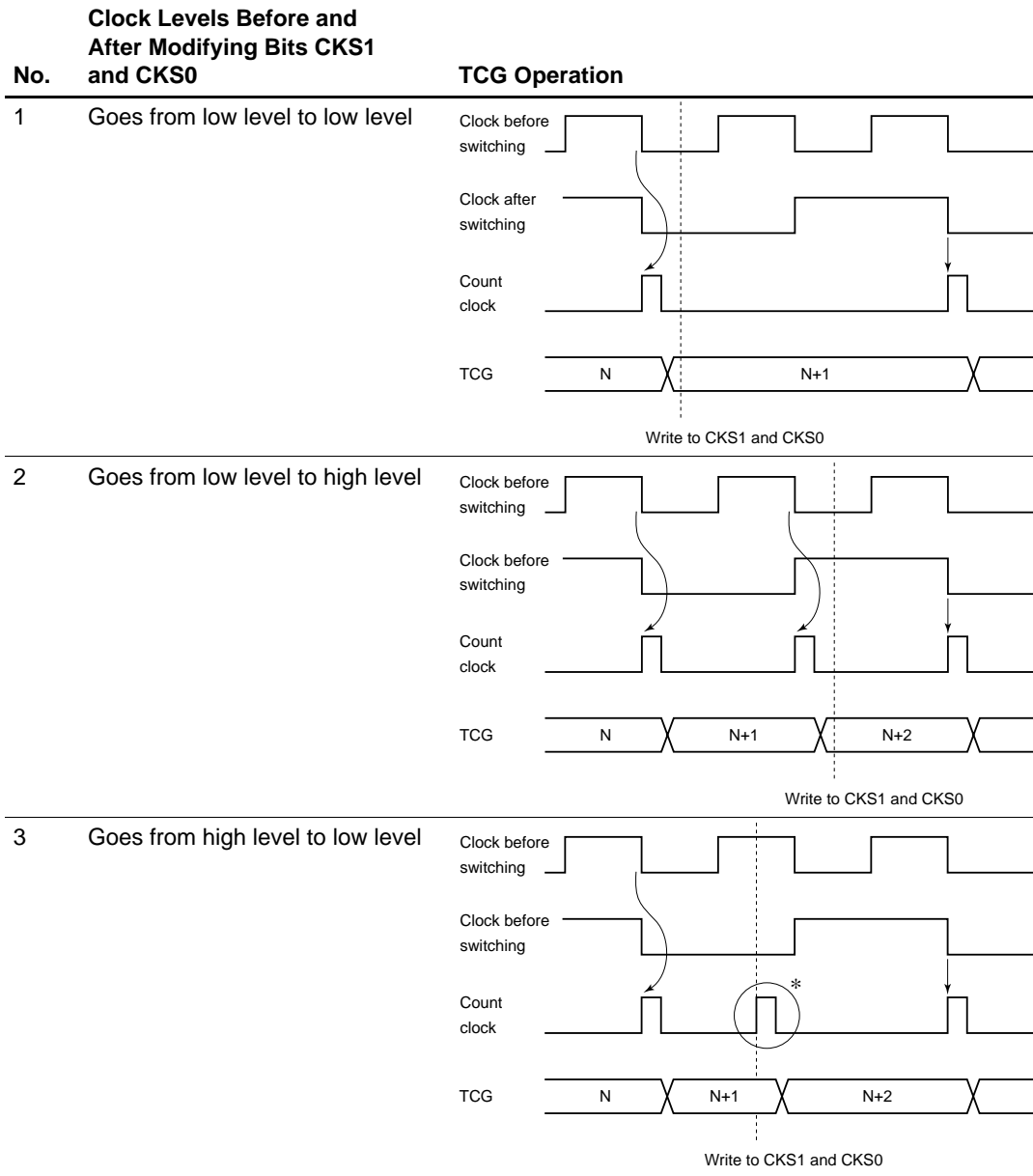

Table 9.14 Internal Clock Switching and TCG Operation (cont)

| No. | Clock Levels Before and After Modifying Bits CKS1 and CKS0 | TCG Operation |
|-----|--|---------------|
| 4 | Goes from high level to high level | |

Note: * The switchover is seen as a falling edge, and TCG is incremented.

2. Notes on port mode register modification

The following points should be noted when a port mode register is modified to switch the input capture function or the input capture input noise canceler function.

- Switching input capture input pin function

Note that when the pin function is switched by modifying TMIG in port mode register 1 (PMR1), which performs input capture input pin control, an edge will be regarded as having been input at the pin even though no valid edge has actually been input. Input capture input signal input edges, and the conditions for their occurrence, are summarized in table 9.15.

Table 9.15 Input Capture Input Signal Input Edges Due to Input Capture Input Pin Switching, and Conditions for Their Occurrence

| Input Capture Input Signal Input Edge | Conditions |
|--|--|
| Generation of rising edge | When TMIG is modified from 0 to 1 while the TMIG pin is high When NCS is modified from 0 to 1 while the TMIG pin is high, then TMIG is modified from 0 to 1 before the signal is sampled five times by the noise canceler |
| Generation of falling edge | When TMIG is modified from 1 to 0 while the TMIG pin is high When NCS is modified from 0 to 1 while the TMIG pin is low, then TMIG is modified from 0 to 1 before the signal is sampled five times by the noise canceler When NCS is modified from 0 to 1 while the TMIG pin is high, then TMIG is modified from 1 to 0 after the signal is sampled five times by the noise canceler |

Note: When the P1₃ pin is not set as an input capture input pin, the timer G input capture input signal is low.

- Switching input capture input noise canceler function

When performing noise canceler function switching by modifying NCS in port mode register 3 (PMR3), which controls the input capture input noise canceler, TMIG should first be cleared to 0. Note that if NCS is modified without first clearing TMIG, an edge will be regarded as having been input at the pin even though no valid edge has actually been input. Input capture input signal input edges, and the conditions for their occurrence, are summarized in table 9.16.

Table 9.16 Input Capture Input Signal Input Edges Due to Noise Canceler Function Switching, and Conditions for Their Occurrence

| Input Capture Input Signal Input Edge | Conditions |
|--|---|
| Generation of rising edge | When the TMIG pin level is switched from low to high while TMIG is set to 1, then NCS is modified from 0 to 1 before the signal is sampled five times by the noise canceler |
| Generation of falling edge | When the TMIG pin level is switched from high to low while TMIG is set to 1, then NCS is modified from 1 to 0 before the signal is sampled five times by the noise canceler |

When the pin function is switched and an edge is generated in the input capture input signal, if this edge matches the edge selected by the input capture interrupt select (IIEGS) bit, the interrupt request flag will be set to 1. The interrupt request flag should therefore be cleared to 0 before use. Figure 9.14 shows the procedure for port mode register manipulation and interrupt request flag clearing. When switching the pin function, set the interrupt-disabled state before manipulating the port mode register, then, after the port mode register operation has been performed, wait for the time required to confirm the input capture input signal as an input capture signal (at least two system clocks when the noise canceler is not used; at least five sampling clocks when the noise canceler is used), before clearing the interrupt enable flag to 0. There are two ways of preventing interrupt request flag setting when the pin function is switched: by controlling the pin level so that the conditions shown in tables 9.15 and 9.16 are not satisfied, or by setting the opposite of the generated edge in the IIEGS bit in TMG.

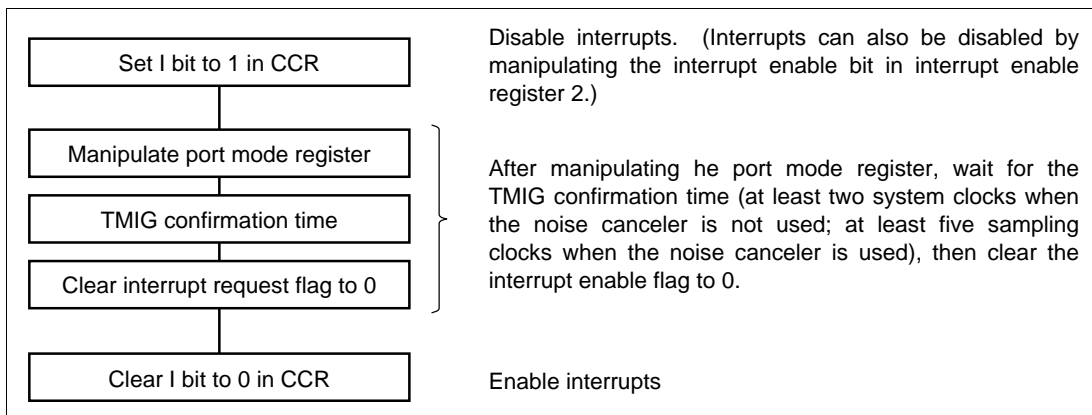

Figure 9.14 Port Mode Register Manipulation and Interrupt Enable Flag Clearing Procedure

9.5.6 Timer G Application Example

Using timer G, it is possible to measure the high and low widths of the input capture input signal as absolute values. For this purpose, CCLR1 and CCLR0 should both be set to 1 in TMG.

Figure 9.15 shows an example of the operation in this case.

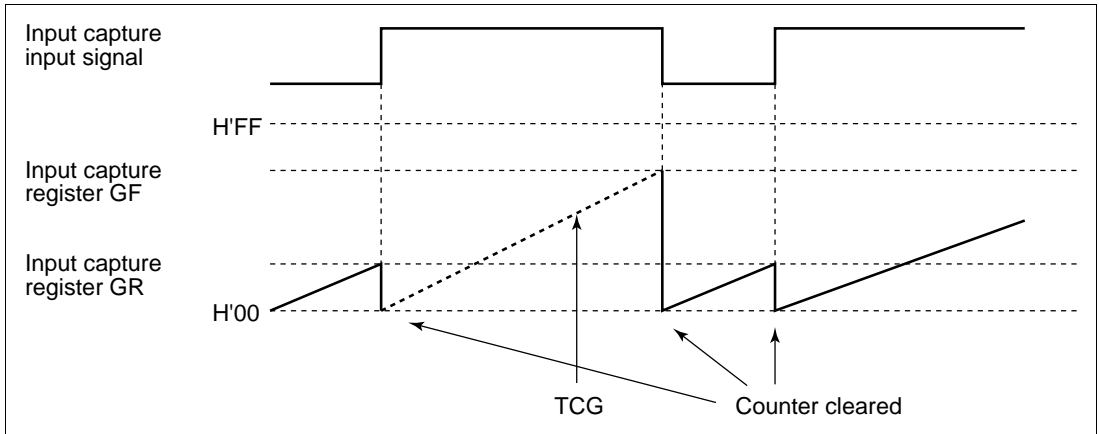

Figure 9.15 Timer G Application Example

9.6 Watchdog Timer

9.6.1 Overview

The watchdog timer has an 8-bit counter that is incremented by an input clock. If a system runaway allows the counter value to overflow before being rewritten, the watchdog timer can reset the chip internally.

1. Features

Features of the watchdog timer are given below.

- Incremented by internal clock source ($\phi/8192$ or $\phi_w/32$).
- A reset signal is generated when the counter overflows. The overflow period can be set from from 1 to 256 times $8192/\phi$ or $32/\phi_w$ (from approximately 4 ms to 1000 ms when $\phi = 2.00$ MHz).
- Use of module standby mode enables this module to be placed in standby mode independently when not used.

2. Block diagram

Figure 9.16 shows a block diagram of the watchdog timer.

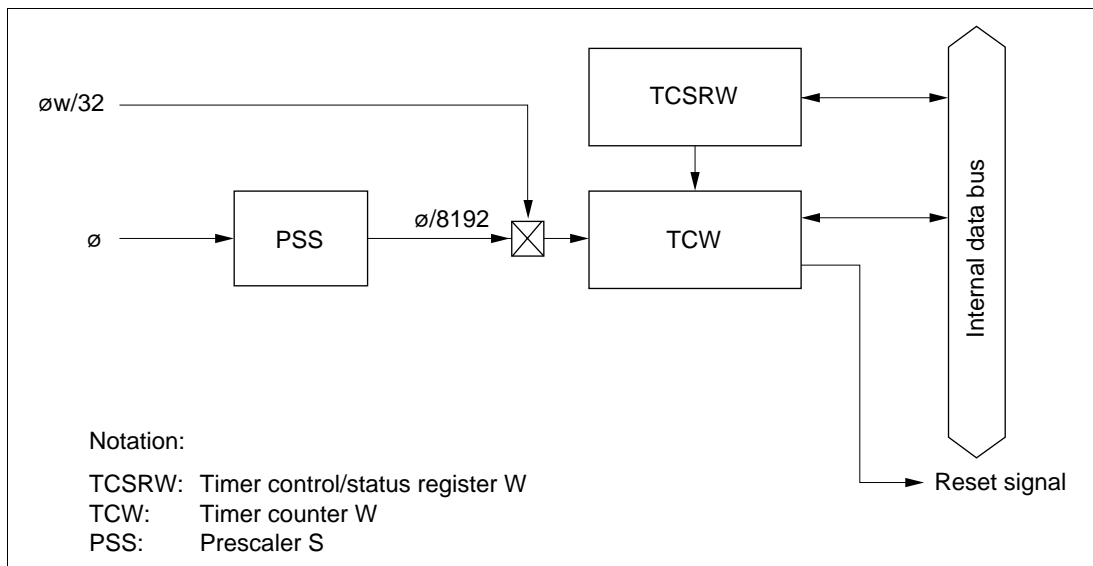

Figure 9.16 Block Diagram of Watchdog Timer

3. Register configuration

Table 9.17 shows the register configuration of the watchdog timer.

Table 9.17 Watchdog Timer Registers

| Name | Abbrev. | R/W | Initial Value | Address |
|---------------------------------|---------|-----|---------------|---------|
| Timer control/status register W | TCSRW | R/W | H'AA | H'FFB2 |
| Timer counter W | TCW | R/W | H'00 | H'FFB3 |
| Clock stop register 2 | CKSTP2 | R/W | H'FF | H'FFFB |
| Port mode register 3 | PMR3 | R/W | H'00 | H'FFCA |

9.6.2 Register Descriptions

1. Timer control/status register W (TCSRW)

| | | | | | | | | |
|---------------|------|------|------|--------|------|------|------|------|
| Bit | 7 | 6 | 5 | 4 | 3 | 2 | 1 | 0 |
| | B6WI | TCWE | B4WI | TCSRWE | B2WI | WDON | B0WI | WRST |
| Initial value | 1 | 0 | 1 | 0 | 1 | 0 | 1 | 0 |
| Read/Write | R | R/W* | R | R/W* | R | R/W* | R | R/W* |

Note: * Write is permitted only under certain conditions, which are given in the descriptions of the individual bits.

TCSRW is an 8-bit read/write register that controls write access to TCW and TCSRW itself, controls watchdog timer operations, and indicates operating status.

Bit 7: Bit 6 write inhibit (B6WI)

Bit 7 controls the writing of data to bit 6 in TCSRW.

Bit 7

| B6WI | Description |
|------|--|
| 0 | Bit 6 is write-enabled |
| 1 | Bit 6 is write-protected (initial value) |

This bit is always read as 1. Data written to this bit is not stored.

Bit 6: Timer counter W write enable (TCWE)

Bit 6 controls the writing of data to TCW.

Bit 6

| TCWE | Description |
|------|---|
| 0 | Data cannot be written to TCW (initial value) |
| 1 | Data can be written to TCW |

Bit 5: Bit 4 write inhibit (B4WI)

Bit 5 controls the writing of data to bit 4 in TCSRW.

Bit 5

| B4WI | Description |
|------|--|
| 0 | Bit 4 is write-enabled |
| 1 | Bit 4 is write-protected (initial value) |

This bit is always read as 1. Data written to this bit is not stored.

Bit 4: Timer control/status register W write enable (TCSRWE)

Bit 4 controls the writing of data to TCSRW bits 2 and 0.

Bit 4

| TCSRWE | Description |
|--------|--|
| 0 | Data cannot be written to bits 2 and 0 (initial value) |
| 1 | Data can be written to bits 2 and 0 |

Bit 3: Bit 2 write inhibit (B2WI)

Bit 3 controls the writing of data to bit 2 in TCSRW.

Bit 3

| B2WI | Description |
|------|--|
| 0 | Bit 2 is write-enabled |
| 1 | Bit 2 is write-protected (initial value) |

This bit is always read as 1. Data written to this bit is not stored.

Bit 2: Watchdog timer on (WDON)

Bit 2 enables watchdog timer operation.

Bit 2

| WDON | Description |
|------|--|
| 0 | Watchdog timer operation is disabled (initial value) Clearing conditions: Reset, or when TCSRWE = 1 and 0 is written in both B2WI and WDON |
| 1 | Watchdog timer operation is enabled Setting conditions: When TCSRWE = 1 and 0 is written in B2WI and 1 is written in WDON |

Counting starts when this bit is set to 1, and stops when this bit is cleared to 0.

Bit 1: Bit 0 write inhibit (B0WI)

Bit 1 controls the writing of data to bit 0 in TCSRW.

Bit 1

| B0WI | Description |
|------|--|
| 0 | Bit 0 is write-enabled |
| 1 | Bit 0 is write-protected (initial value) |

This bit is always read as 1. Data written to this bit is not stored.

Bit 0: Watchdog timer reset (WRST)

Bit 0 indicates that TCW has overflowed, generating an internal reset signal. The internal reset signal generated by the overflow resets the entire chip. WRST is cleared to 0 by a reset from the $\overline{\text{RES}}$ pin, or when software writes 0.

Bit 0

| WRST | Description |
|------|---|
| 0 | Clearing conditions: Reset by $\overline{\text{RES}}$ pin When TCSRWE = 1, and 0 is written in both B0WI and WRST |
| 1 | Setting conditions: When TCW overflows and an internal reset signal is generated |

2. Timer counter W (TCW)

| | | | | | | | | |
|---------------|------|------|------|------|------|------|------|------|
| Bit | 7 | 6 | 5 | 4 | 3 | 2 | 1 | 0 |
| | TCW7 | TCW6 | TCW5 | TCW4 | TCW3 | TCW2 | TCW1 | TCW0 |
| Initial value | 0 | 0 | 0 | 0 | 0 | 0 | 0 | 0 |
| Read/Write | R/W | R/W | R/W | R/W | R/W | R/W | R/W | R/W |

TCW is an 8-bit read/write up-counter, which is incremented by internal clock input. The input clock is $\phi/8192$ or $\phi_w/32$. The TCW value can always be written or read by the CPU.

When TCW overflows from H'FF to H'00, an internal reset signal is generated and WRST is set to 1 in TCSRW. Upon reset, TCW is initialized to H'00.

3. Clock stop register 2 (CKSTPR2)

| | | | | | | | | |
|---------------|---|---|---|---|---------|---------|---------|---------|
| Bit | 7 | 6 | 5 | 4 | 3 | 2 | 1 | 0 |
| | — | — | — | — | AECKSTP | WDCKSTP | PWCKSTP | LDCKSTP |
| Initial value | 1 | 1 | 1 | 1 | 1 | 1 | 1 | 1 |
| Read/Write | — | — | — | — | R/W | R/W | R/W | R/W |

CKSTPR2 is an 8-bit read/write register that performs module standby mode control for peripheral modules. Only the bit relating to the watchdog timer is described here. For details of the other bits, see the sections on the relevant modules.

Bit 2: Watchdog timer module standby mode control (WDCKSTP)

Bit 2 controls setting and clearing of module standby mode for the watchdog timer.

| WDCKSTP | Description |
|---------|---|
| 0 | Watchdog timer is set to module standby mode |
| 1 | Watchdog timer module standby mode is cleared (initial value) |

Note: WDCKSTP is valid when the WDON bit is cleared to 0 in timer control/status register W (TCSRW). If WDCKSTP is set to 0 while WDON is set to 1 (during watchdog timer operation), 0 will be set in WDCKSTP but the watchdog timer will continue its watchdog function and will not enter module standby mode. When the watchdog function ends and WDON is cleared to 0 by software, the WDCKSTP setting will become valid and the watchdog timer will enter module standby mode.

4. Port mode register 3 (PMR3)

PMR3 is an 8-bit read/write register, mainly controlling the selection of pin functions for port 3 pins. Only the bit relating to the watchdog timer is described here. For details of the other bits, see section 8, I/O Ports.

Bit 5: Watchdog timer source clock select (WDCKS)

| WDCKS | Description | |
|-------|----------------------|-----------------|
| 0 | $\phi/8192$ selected | (initial value) |
| 1 | $\phi w/32$ selected | |

9.6.3 Timer Operation

The watchdog timer has an 8-bit counter (TCW) that is incremented by clock input ($\phi/8192$ or $\phi w/32$). The input clock is selected by bit WDCKS in port mode register 3 (PMR3): $\phi/8192$ is selected when WDCKS is cleared to 0, and $\phi w/32$ when set to 1. When TCSRWE = 1 in TCSRW, if 0 is written in B2WI and 1 is simultaneously written in WDON, TCW starts counting up. When the TCW count reaches H'FF, the next clock input causes the watchdog timer to overflow, and an internal reset signal is generated one reference clock (ϕ or ϕ_{SUB}) cycle later. The internal reset signal is output for 512 clock cycles of the ϕ_{OSC} clock. It is possible to write to TCW, causing TCW to count up from the written value. The overflow period can be set in the range from 1 to 256 input clocks, depending on the value written in TCW.

Figure 9.17 shows an example of watchdog timer operations.

Example: $\phi = 2$ MHz and the desired overflow period is 30 ms.

$$\frac{2 \times 10^6}{8192} \times 30 \times 10^{-3} = 7.3$$

The value set in TCW should therefore be $256 - 8 = 248$ (H'F8).

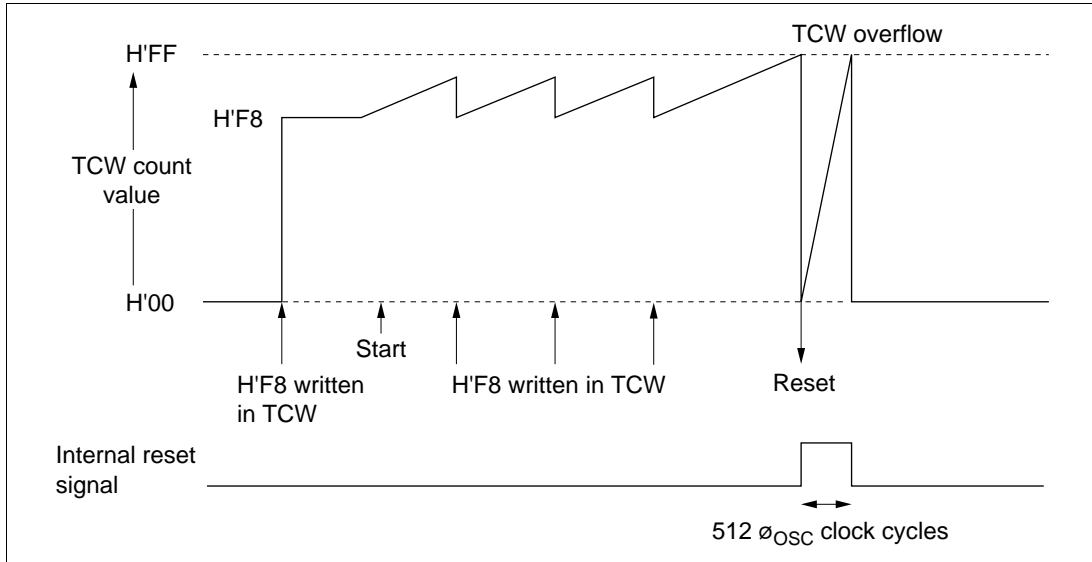

Figure 9.17 Typical Watchdog Timer Operations (Example)

9.6.4 Watchdog Timer Operation States

Table 9.18 summarizes the watchdog timer operation states.

Table 9.18 Watchdog Timer Operation States

| Operation Mode | Reset | Active | Sleep | Watch | Sub-active | Sub-sleep | Standby | Module Standby |
|----------------|-------|-----------|-----------|----------|-----------------------|-----------|----------|----------------|
| TCW | Reset | Functions | Functions | Halted | Functions/ Halted* | Halted | Halted | Halted |
| TCSRW | Reset | Functions | Functions | Retained | Functions/ Halted* | Retained | Retained | Retained |

Note: * Functions when $\phi w/32$ is selected as the input clock.

9.7 Asynchronous Event Counter (AEC)

9.7.1 Overview

The asynchronous event counter is incremented by external event clock input.

1. Features

Features of the asynchronous event counter are given below.

- Can count asynchronous events

Can count external events input asynchronously without regard to the operation of base clocks ϕ and ϕ_{SUB} .

The counter has a 16-bit configuration, enabling it to count up to 65536 (2^{16}) events.

- Can also be used as two independent 8-bit event counter channels.
- Counter resetting and halting of the count-up function controllable by software
- Automatic interrupt generation on detection of event counter overflow
- Use of module standby mode enables this module to be placed in standby mode independently when not used.

2. Block diagram

Figure 9.18 shows a block diagram of the asynchronous event counter.

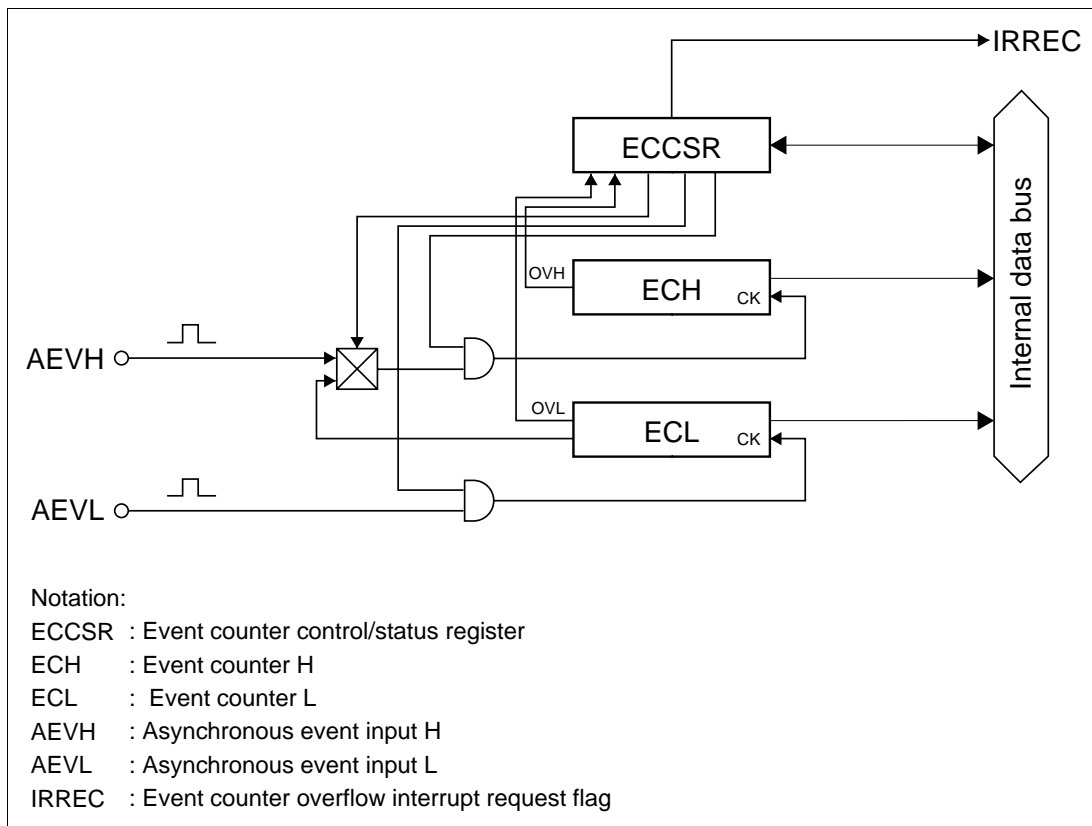

Figure 9.18 Block Diagram of Asynchronous Event Counter

3. Pin configuration

Table 9.19 shows the asynchronous event counter pin configuration.

Table 9.19 Pin Configuration

| Name | Abbrev. | I/O | Function |
|----------------------------|---------|-------|--|
| Asynchronous event input H | AEVH | Input | Event input pin for input to event counter H |
| Asynchronous event input L | AEVL | Input | Event input pin for input to event counter L |

4. Register configuration

Table 9.20 shows the register configuration of the asynchronous event counter.

Table 9.20 Asynchronous Event Counter Registers

| Name | Abbrev. | R/W | Initial Value | Address |
|---------------------------------------|---------|-----|---------------|---------|
| Event counter control/status register | ECCSR | R/W | H'00 | H'FF95 |
| Event counter H | ECH | R | H'00 | H'FF96 |
| Event counter L | ECL | R | H'00 | H'FF97 |
| Clock stop register 2 | CKSTP2 | R/W | H'FF | H'FFFB |

9.7.2 Register Descriptions

1. Event counter control/status register (ECCSR)

| | | | | | | | | |
|---------------|------|------|-----|-----|------|------|------|------|
| Bit | 7 | 6 | 5 | 4 | 3 | 2 | 1 | 0 |
| | OVH | OVL | — | CH2 | CUEH | CUEL | CRCH | CRCL |
| Initial Value | 0 | 0 | 0 | 0 | 0 | 0 | 0 | 0 |
| Read/Write | R/W* | R/W* | R/W | R/W | R/W | R/W | R/W | R/W |

Note: * Bits 7 and 6 can only be written with 0, for flag clearing.

ECCSR is an 8-bit read/write register that controls counter overflow detection, counter resetting, and halting of the count-up function.

ECCSR is initialized to H'00 upon reset.

Bit 7: Counter overflow flag H (OVH)

Bit 7 is a status flag indicating that ECH has overflowed from H'FF to H'00. This flag is set when ECH overflows. It is cleared by software but cannot be set by software. OVH is cleared by reading it when set to 1, then writing 0.

When ECH and ECL are used as a 16-bit event counter with CH2 cleared to 0, OVH functions as a status flag indicating that the 16-bit event counter has overflowed from H'FFFF to H'0000.

Bit 7

OVH

Description

| 0 | ECH has not overflowed Clearing conditions: After reading OVH = 1, cleared by writing 0 to OVH | (initial value) |
|---|--|-----------------|
| 1 | ECH has overflowed Setting conditions: Set when ECH overflows from H'FF to H'00 | |

Bit 6: Counter overflow flag L (OVL)

Bit 6 is a status flag indicating that ECL has overflowed from H'FF to H'00. This flag is set when ECL overflows. It is cleared by software but cannot be set by software. OVL is cleared by reading it when set to 1, then writing 0.

Bit 6

OVL

Description

| | | |
|---|---|-----------------|
| 0 | ECL has not overflowed Clearing conditions: After reading OVL = 1, cleared by writing 0 to OVL | (initial value) |
| 1 | ECL has overflowed Setting conditions: Set when ECL overflows from H'FF to H'00 while CH2 is set to 1 | |

Bit 5: Reserved bit

Bit 5 is reserved; it can be read and written, and is initialized to 0 upon reset.

Bit 4: Channel select (CH2)

Bit 4 selects whether ECH and ECL are used as a single-channel 16-bit event counter or as two independent 8-bit event counter channels. When CH2 is cleared to 0, ECH and ECL function as a 16-bit event counter which is incremented each time an event clock is input to the AEVL pin as asynchronous event input. In this case, the overflow signal from ECL is selected as the ECH input clock. When CH2 is set to 1, ECH and ECL function as independent 8-bit event counters which are incremented each time an event clock is input to the AEVH or AEVL pin, respectively, as asynchronous event input.

Bit 4

| CH2 | Description |
|-----|---|
| 0 | ECH and ECL are used together as a single-channel 16-bit event counter (initial value) |
| 1 | ECH and ECL are used as two independent 8-bit event counter channels |

Bit 3: Count-up enable H (CUEH)

Bit 3 enables event clock input to ECH. When 1 is written to this bit, event clock input is enabled and increments the counter. When 0 is written to this bit, event clock input is disabled and the ECH value is held. The AEVH pin or the ECL overflow signal can be selected as the event clock source by bit CH2.

Bit 3

| CUEH | Description |
|------|---|
| 0 | ECH event clock input is disabled ECH value is held (initial value) |
| 1 | ECH event clock input is enabled |

Bit 2: Count-up enable L (CUEL)

Bit 3 enables event clock input to ECL. When 1 is written to this bit, event clock input is enabled and increments the counter. When 0 is written to this bit, event clock input is disabled and the ECL value is held.

Bit 2

| CUEL | Description |
|------|---|
| 0 | ECL event clock input is disabled ECL value is held (initial value) |
| 1 | ECL event clock input is enabled |

Bit 1: Counter reset control H (CRCH)

Bit 1 controls resetting of ECH. When this bit is cleared to 0, ECH is reset. When 1 is written to this bit, the counter reset is cleared and the ECH count-up function is enabled.

Bit 1

| CRCH | Description |
|------|---|
| 0 | ECH is reset (initial value) |
| 1 | ECH reset is cleared and count-up function is enabled |

Bit 0: Counter reset control L (CRCL)

Bit 0 controls resetting of ECL. When this bit is cleared to 0, ECL is reset. When 1 is written to this bit, the counter reset is cleared and the ECL count-up function is enabled.

Bit 0

| CRCL | Description |
|------|---|
| 0 | ECL is reset (initial value) |
| 1 | ECL reset is cleared and count-up function is enabled |

2. Event counter H (ECH)

| Bit | 7 | 6 | 5 | 4 | 3 | 2 | 1 | 0 |
|---------------|------|------|------|------|------|------|------|------|
| | ECH7 | ECH6 | ECH5 | ECH4 | ECH3 | ECH2 | ECH1 | ECH0 |
| Initial Value | 0 | 0 | 0 | 0 | 0 | 0 | 0 | 0 |
| Read/Write | R | R | R | R | R | R | R | R |

ECH is an 8-bit read-only up-counter that operates either as an independent 8-bit event counter or as the upper 8-bit up-counter of a 16-bit event counter configured in combination with ECL.

Either the external asynchronous event AEVH pin or the overflow signal from lower 8-bit counter ECL can be selected as the input clock source by bit CH2. ECH can be cleared to H'00 by software, and is also initialized to H'00 upon reset.

3. Event counter L (ECL)

ECL is an 8-bit read-only up-counter that operates either as an independent 8-bit event counter or as the lower 8-bit up-counter of a 16-bit event counter configured in combination with ECH. The event clock from the external asynchronous event AEVL pin is used as the input clock source. ECL can be cleared to H'00 by software, and is also initialized to H'00 upon reset.

| | | | | | | | | |
|---------------|------|------|------|------|------|------|------|------|
| Bit | 7 | 6 | 5 | 4 | 3 | 2 | 1 | 0 |
| | ECL7 | ECL6 | ECL5 | ECL4 | ECL3 | ECL2 | ECL1 | ECL0 |
| Initial Value | 0 | 0 | 0 | 0 | 0 | 0 | 0 | 0 |
| Read/Write | R | R | R | R | R | R | R | R |

4. Clock stop register 2 (CKSTPR2)

| | | | | | | | | |
|---------------|---|---|---|---|---------|---------|---------|---------|
| Bit | 7 | 6 | 5 | 4 | 3 | 2 | 1 | 0 |
| | — | — | — | — | AECKSTP | WDCKSTP | PWCKSTP | LDCKSTP |
| Initial value | 1 | 1 | 1 | 1 | 1 | 1 | 1 | 1 |
| Read/Write | — | — | — | — | R/W | R/W | R/W | R/W |

CKSTPR2 is an 8-bit read/write register that performs module standby mode control for peripheral modules. Only the bit relating to the asynchronous event counter is described here. For details of the other bits, see the sections on the relevant modules.

Bit 3: Asynchronous event counter module standby mode control (AECKSTP)

Bit 3 controls setting and clearing of module standby mode for the asynchronous event counter.

| AECKSTP | Description |
|---------|-------------|
|---------|-------------|

| | |
|---|---|
| 0 | Asynchronous event counter is set to module standby mode |
| 1 | Asynchronous event counter module standby mode is cleared (initial value) |

9.7.3 Operation

1. 16-bit event counter operation

When bit CH2 is cleared to 0 in ECCSR, ECH and ECL operate as a 16-bit event counter. Figure 9.19 shows an example of the software processing when ECH and ECL are used as a 16-bit event counter.

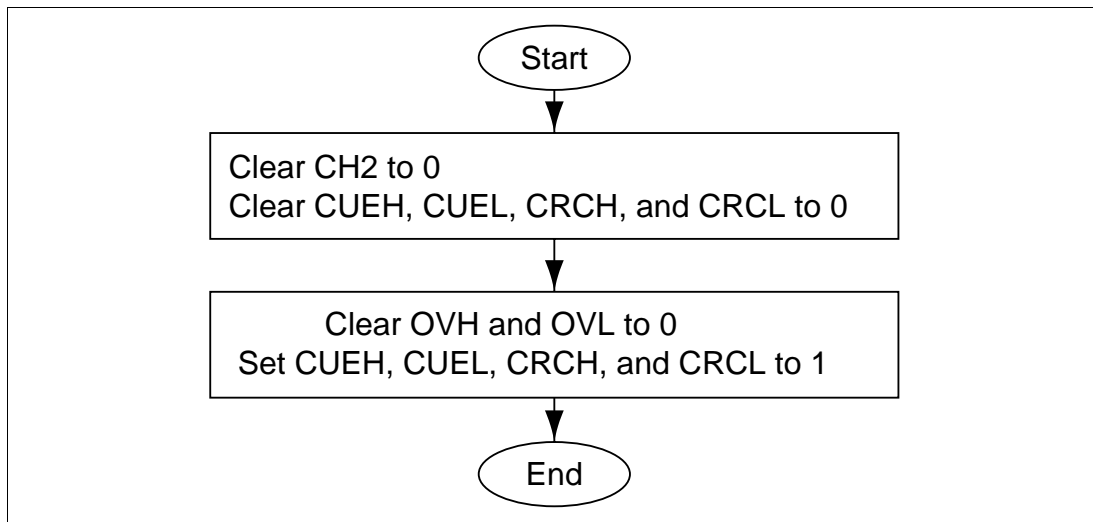

Figure 9.19 Example of Software Processing when Using ECH and ECL as 16-Bit Event Counter

As CH2 is cleared to 0 by a reset, ECH and ECL operate as a 16-bit event counter after a reset. They can also be used as a 16-bit event counter by carrying out the software processing shown in the example in figure 9.19. The operating clock source is asynchronous event input from the AEVL pin. When the next clock is input after the count value reaches H'FF in both ECH and ECL, ECH and ECL overflow from H'FFFF to H'0000, the OVH flag is set to 1 in ECCSR, the ECH and ECL count values each return to H'00, and counting up is restarted. When overflow occurs, the IRREC bit is set to 1 in IRR2. If the IENEC bit in IENR2 is 1 at this time, an interrupt request is sent to the CPU.

2. 8-bit event counter operation

When bit CH2 is set to 1 in ECCSR, ECH and ECL operate as independent 8-bit event counters. Figure 9.20 shows an example of the software processing when ECH and ECL are used as 8-bit event counters.

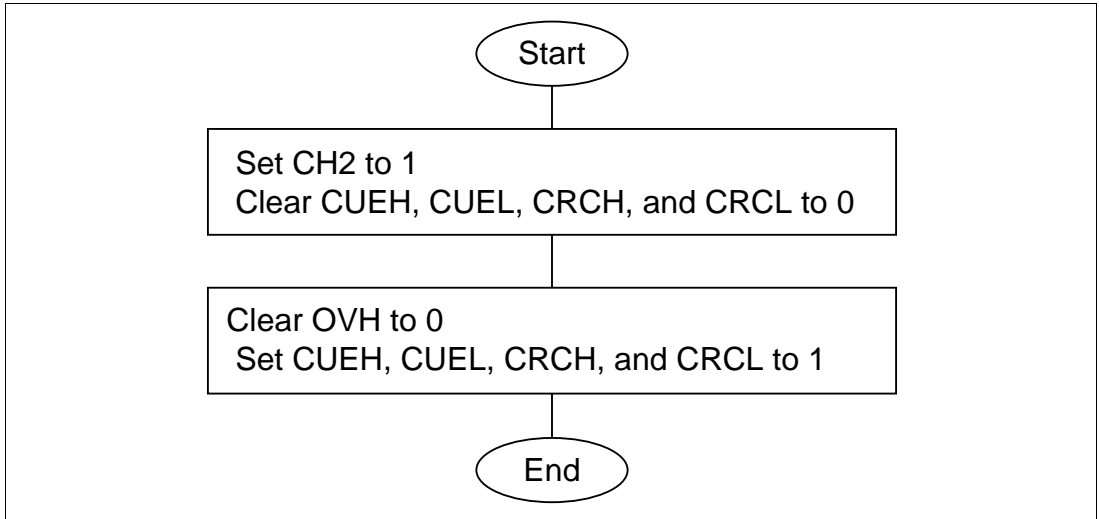

Figure 9.20 Example of Software Processing when Using ECH and ECL as 8-Bit Event Counters

ECH and ECL can be used as 8-bit event counters by carrying out the software processing shown in the example in figure 9.20. The 8-bit event counter operating clock source is asynchronous event input from the AEVH pin for ECH, and asynchronous event input from the AEVL pin for ECL. When the next clock is input after the ECH count value reaches H'FF, ECH overflows, the OVH flag is set to 1 in ECCSR, the ECH count value returns to H'00, and counting up is restarted. Similarly, when the next clock is input after the ECL count value reaches H'FF, ECL overflows, the OVL flag is set to 1 in ECCSR, the ECL count value returns to H'00, and counting up is restarted. When overflow occurs, the IRREC bit is set to 1 in IRR2. If the IENEC bit in IENR2 is 1 at this time, an interrupt request is sent to the CPU.

9.7.4 Asynchronous Event Counter Operation Modes

Asynchronous event counter operation modes are shown in table 9.21.

Table 9.21 Asynchronous Event Counter Operation Modes

| Operation Mode | Reset | Active | Sleep | Watch | Sub-active | Sub-sleep | Standby | Module Standby |
|----------------|-------|-----------|------------|------------|------------|-----------|------------|----------------|
| ECCSR | Reset | Functions | Functions | Held* | Functions | Functions | Held* | Held |
| ECH | Reset | Functions | Functions* | Functions* | Functions | Functions | Functions* | Halted |
| ECL | Reset | Functions | Functions* | Functions* | Functions | Functions | Functions* | Halted |

Note: * When an asynchronous external event is input, the counter increments but the counter overflow H/L flags are not affected.

9.7.5 Application Notes

1. When reading the values in ECH and ECL, first clear bits CUEH and CUEL to 0 in ECCSR to prevent asynchronous event input to the counter. The correct value will not be returned if the event counter increments while being read.

When clear bits CUEH and CUEL to 0 in ECCSR, ECH and ECL sometimes count up.

2. Use a clock with a frequency of up to 6 MHz (Internal step-down circuit not used: $V_{CC} = 4.5$ to 5.5 V), up to 4 MHz (Internal step-down circuit not used: $V_{CC} = 3.0$ to 5.5 V), up to 3.2 MHz (internal step-down circuit not used: $V_{CC} = 2.7$ to 5.5 V), up to 2 MHz ($V_{CC} = 2.2$ to 5.5 V), up to 1 MHz (others) for input to the AEVH and AEVL pins, and ensure that the high and low widths of the clock are at least 83 ns. The duty cycle is immaterial.

| Mode | | Maximum AEVH/AEVL Pin Input Clock Frequency |
|-------------|--|--|
| 16-bit mode | | Internal step-down circuit |
| 8-bit mode | Active (high-speed), sleep (high-speed) | not used: $V_{CC} = 4.5$ to 5.5 V/6 MHz $V_{CC} = 3.0$ to 5.5 V/4 MHz $V_{CC} = 2.6$ to 5.5 V/3.2 MHz $V_{CC} = 2.2$ to 5.5 V/2 MHz Other than above/1 MHz Internal step-down circuit used: $V_{CC} = 2.2$ to 5.5 V/2 MHz Other than above/1 MHz |
| 8-bit mode | Active (medium-speed), sleep (medium-speed) ($\emptyset/16$) | $2 \cdot f_{OSC}$ |
| | | ($\emptyset/32$) f_{OSC} |
| | | ($\emptyset/64$) $1/2 \cdot f_{OSC}$ |
| | $f_{OSC} = 400$ kHz to 4 MHz | ($\emptyset/128$) $1/4 \cdot f_{OSC}$ |
| 8-bit mode | Watch, subactive, subsleep, standby | ($\emptyset w/2$) 1000 kHz |
| | | ($\emptyset w/4$) 500 kHz |
| | $\emptyset w = 32.768$ kHz or 38.4 kHz | ($\emptyset w/8$) 250 kHz |

3. When AEC uses with 16-bit mode, set CUEH in ECCSR to “1” first, set CRCH in ECCSR to “1” second, or set both CUEH and CRCH to “1” at same time before clock entry. While AEC is operating on 16-bit mode, do not change CUEH. Otherwise, ECH will be miscounted up.

Section 10 Serial Communication Interface

10.1 Overview

The H8/3864 Series is provided with two serial communication interfaces, SCI3-1 and SCI3-2. These two SCIs have identical functions. In this manual, the generic term SCI3 is used to refer to both SCIs.

Serial communication interface 3 (SCI3) can carry out serial data communication in either asynchronous or synchronous mode. It is also provided with a multiprocessor communication function that enables serial data to be transferred among processors.

10.1.1 Features

Features of SCI3 are listed below.

- Choice of asynchronous or synchronous mode for serial data communication

- Asynchronous mode

Serial data communication is performed asynchronously, with synchronization provided character by character. In this mode, serial data can be exchanged with standard asynchronous communication LSIs such as a Universal Asynchronous Receiver/Transmitter (UART) or Asynchronous Communication Interface Adapter (ACIA). A multiprocessor communication function is also provided, enabling serial data communication among processors.

There is a choice of 16 data transfer formats.

| | |
|-------------------------|--|
| Data length | 7, 8, 5 bits |
| Stop bit length | 1 or 2 bits |
| Parity | Even, odd, or none |
| Multiprocessor bit | "1" or "0" |
| Receive error detection | Parity, overrun, and framing errors |
| Break detection | Break detected by reading the RXD _{3x} pin level directly when a framing error occurs |

— Synchronous mode

Serial data communication is synchronized with a clock. In this mode, serial data can be exchanged with another LSI that has a synchronous communication function.

| | |
|-------------------------|----------------|
| Data length | 8 bits |
| Receive error detection | Overrun errors |

- Full-duplex communication
Separate transmission and reception units are provided, enabling transmission and reception to be carried out simultaneously. The transmission and reception units are both double-buffered, allowing continuous transmission and reception.
- On-chip baud rate generator, allowing any desired bit rate to be selected
- Choice of an internal or external clock as the transmit/receive clock source
- Six interrupt sources: transmit end, transmit data empty, receive data full, overrun error, framing error, and parity error

10.1.2 Block diagram

Figure 10.1 shows a block diagram of SCI3.

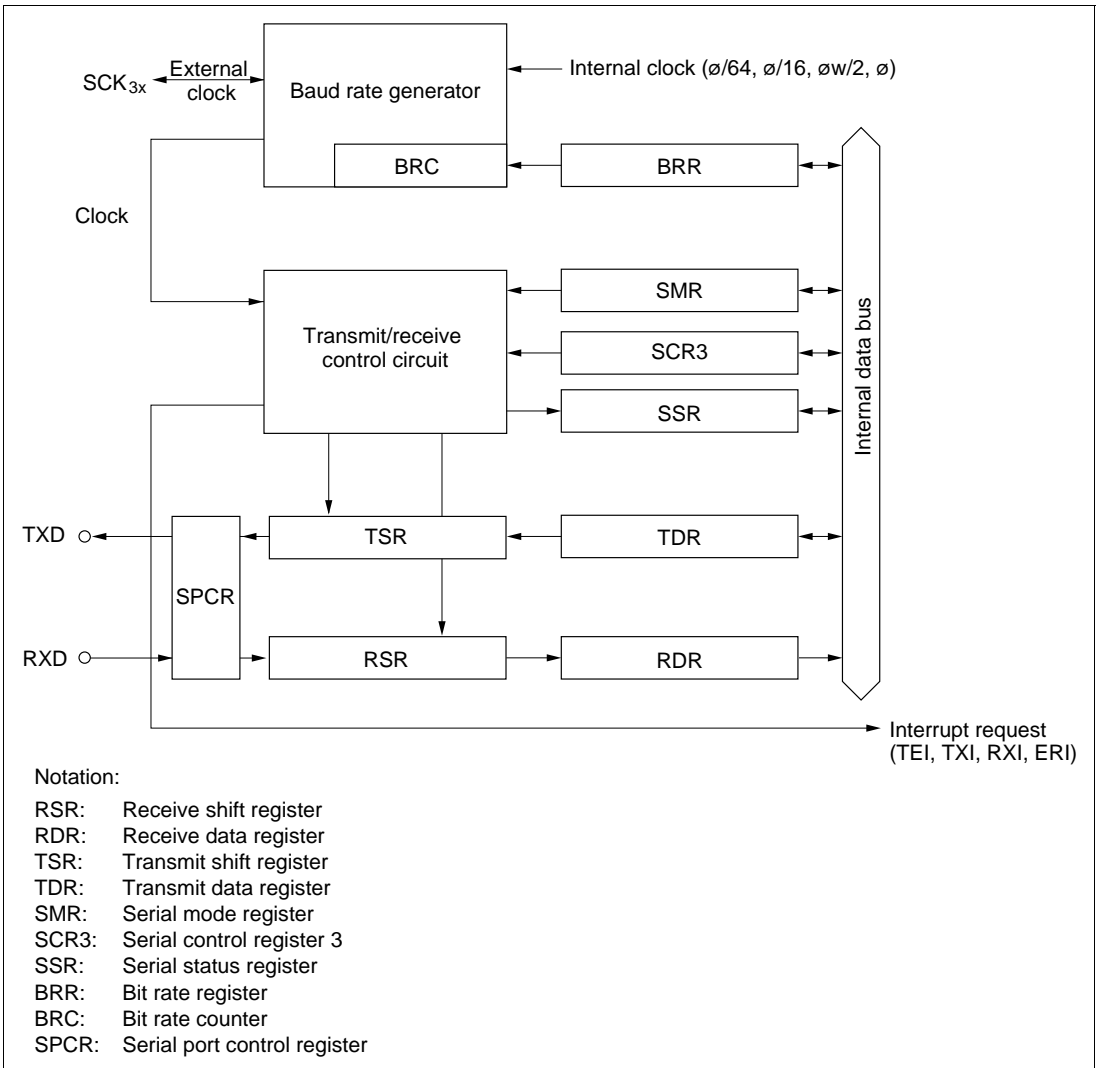

Figure 10.1 SCI3 Block Diagram

10.1.3 Pin configuration

Table 10.1 shows the SCI3 pin configuration.

Table 10.1 Pin Configuration

| Name | Abbrev. | I/O | Function |
|---------------------------|-------------------|--------|---------------------------|
| SCI3 clock | SCK _{3x} | I/O | SCI3 clock input/output |
| SCI3 receive data input | RXD _{3x} | Input | SCI3 receive data input |
| SCI3 transmit data output | TXD _{3x} | Output | SCI3 transmit data output |

10.1.4 Register configuration

Table 10.2 shows the SCI3 register configuration.

Table 10.2 Registers

| Name | Abbrev. | R/W | Initial Value | Address |
|------------------------------|---------|-----------|---------------|-------------|
| Serial mode register | SMR | R/W | H'00 | H'FFA8/FF98 |
| Bit rate register | BRR | R/W | H'FF | H'FFA9/FF99 |
| Serial control register 3 | SCR3 | R/W | H'00 | H'FFAA/FF9A |
| Transmit data register | TDR | R/W | H'FF | H'FFAB/FF9B |
| Serial data register | SSR | R/W | H'84 | H'FFAC/FF9C |
| Receive data register | RDR | R | H'00 | H'FFAD/FF9D |
| Transmit shift register | TSR | Protected | — | — |
| Receive shift register | RSR | Protected | — | — |
| Bit rate counter | BRC | Protected | — | — |
| Clock stop register 1 | CKSTPR1 | R/W | H'FF | H'FFFA |
| Serial port control register | SPCR | R/W | H'C0 | H'FF91 |

10.2 Register Descriptions

10.2.1 Receive shift register (RSR)

| | | | | | | | | |
|------------|---|---|---|---|---|---|---|---|
| Bit | 7 | 6 | 5 | 4 | 3 | 2 | 1 | 0 |
| | | | | | | | | |
| Read/Write | — | — | — | — | — | — | — | — |

RSR is a register used to receive serial data. Serial data input to RSR from the RXD_{3x} pin is set in the order in which it is received, starting from the LSB (bit 0), and converted to parallel data. When one byte of data is received, it is transferred to RDR automatically.

RSR cannot be read or written directly by the CPU.

10.2.2 Receive data register (RDR)

| | | | | | | | | |
|---------------|------|------|------|------|------|------|------|------|
| Bit | 7 | 6 | 5 | 4 | 3 | 2 | 1 | 0 |
| | RDR7 | RDR6 | RDR5 | RDR4 | RDR3 | RDR2 | RDR1 | RDR0 |
| Initial value | 0 | 0 | 0 | 0 | 0 | 0 | 0 | 0 |
| Read/Write | R | R | R | R | R | R | R | R |

RDR is an 8-bit register that stores received serial data.

When reception of one byte of data is finished, the received data is transferred from RSR to RDR, and the receive operation is completed. RSR is then able to receive data. RSR and RDR are double-buffered, allowing consecutive receive operations.

RDR is a read-only register, and cannot be written by the CPU.

RDR is initialized to H'00 upon reset, and in standby, module standby or watch mode.

10.2.3 Transmit shift register (TSR)

| | | | | | | | | |
|------------|---|---|---|---|---|---|---|---|
| Bit | 7 | 6 | 5 | 4 | 3 | 2 | 1 | 0 |
| | | | | | | | | |
| Read/Write | — | — | — | — | — | — | — | — |

TSR is a register used to transmit serial data. Transmit data is first transferred from TDR to TSR, and serial data transmission is carried out by sending the data to the TXD_{3x} pin in order, starting from the LSB (bit 0). When one byte of data is transmitted, the next byte of transmit data is transferred to TDR, and transmission started, automatically. Data transfer from TDR to TSR is not performed if no data has been written to TDR (if bit TDRE is set to 1 in the serial status register (SSR)).

TSR cannot be read or written directly by the CPU.

10.2.4 Transmit data register (TDR)

| | | | | | | | | |
|---------------|------|------|------|------|------|------|------|------|
| Bit | 7 | 6 | 5 | 4 | 3 | 2 | 1 | 0 |
| | TDR7 | TDR6 | TDR5 | TDR4 | TDR3 | TDR2 | TDR1 | TDR0 |
| Initial value | 1 | 1 | 1 | 1 | 1 | 1 | 1 | 1 |
| Read/Write | R/W | R/W | R/W | R/W | R/W | R/W | R/W | R/W |

TDR is an 8-bit register that stores transmit data. When TSR is found to be empty, the transmit data written in TDR is transferred to TSR, and serial data transmission is started. Continuous transmission is possible by writing the next transmit data to TDR during TSR serial data transmission.

TDR can be read or written by the CPU at any time.

TDR is initialized to H'FF upon reset, and in standby, module standby, or watch mode.

10.2.5 Serial mode register (SMR)

| | | | | | | | | |
|---------------|-----|-----|-----|-----|------|-----|------|------|
| Bit | 7 | 6 | 5 | 4 | 3 | 2 | 1 | 0 |
| | COM | CHR | PE | PM | STOP | MP | CKS1 | CKS0 |
| Initial value | 0 | 0 | 0 | 0 | 0 | 0 | 0 | 0 |
| Read/Write | R/W | R/W | R/W | R/W | R/W | R/W | R/W | R/W |

SMR is an 8-bit register used to set the serial data transfer format and to select the clock source for the baud rate generator.

SMR can be read or written by the CPU at any time.

SMR is initialized to H'00 upon reset, and in standby, module standby, or watch mode.

Bit 7: Communication mode (COM)

Bit 7 selects whether SCI3 operates in asynchronous mode or synchronous mode.

Bit 7

| COM | Description |
|-----|-----------------------------------|
| 0 | Asynchronous mode (initial value) |
| 1 | Synchronous mode |

Bit 6: Character length (CHR)

Bit 6 selects either 7 or 8 bits as the data length to be used in asynchronous mode. In synchronous mode the data length is always 8 bits, irrespective of the bit 6 setting.

Bit 6

| CHR | Description |
|-----|---|
| 0 | 8-bit data/5-bit data* ² (initial value) |
| 1 | 7-bit data* ¹ /5-bit data* ² |

Notes: 1. When 7-bit data is selected, the MSB (bit 7) of TDR is not transmitted.

2. When 5-bit data is selected, set both PE and MP to 1. The three most significant bits (bits 7, 6, and 5) of TDR are not transmitted.

Bit 5: Parity enable (PE)

Bit 5 selects whether a parity bit is to be added during transmission and checked during reception in asynchronous mode. In synchronous mode parity bit addition and checking is not performed, irrespective of the bit 5 setting.

Bit 5

| PE | Description |
|----|---|
| 0 | Parity bit addition and checking disabled ^{*2} (initial value) |
| 1 | Parity bit addition and checking enabled ^{*1/*2} |

- Notes:
1. When PE is set to 1, even or odd parity, as designated by bit PM, is added to transmit data before it is sent, and the received parity bit is checked against the parity designated by bit PM.
 2. For the case where 5-bit data is selected, see table 10.11.

Bit 4: Parity mode (PM)

Bit 4 selects whether even or odd parity is to be used for parity addition and checking. The PM bit setting is only valid in asynchronous mode when bit PE is set to 1, enabling parity bit addition and checking. The PM bit setting is invalid in synchronous mode, and in asynchronous mode if parity bit addition and checking is disabled.

Bit 4

| PM | Description |
|----|---|
| 0 | Even parity ^{*1} (initial value) |
| 1 | Odd parity ^{*2} |

- Notes:
1. When even parity is selected, a parity bit is added in transmission so that the total number of 1 bits in the transmit data plus the parity bit is an even number; in reception, a check is carried out to confirm that the number of 1 bits in the receive data plus the parity bit is an even number.
 2. When odd parity is selected, a parity bit is added in transmission so that the total number of 1 bits in the transmit data plus the parity bit is an odd number; in reception, a check is carried out to confirm that the number of 1 bits in the receive data plus the parity bit is an odd number.

Bit 3: Stop bit length (STOP)

Bit 3 selects 1 bit or 2 bits as the stop bit length is asynchronous mode. The STOP bit setting is only valid in asynchronous mode. When synchronous mode is selected the STOP bit setting is invalid since stop bits are not added.

Bit 3

| STOP | Description | |
|------|---------------------------|-----------------|
| 0 | 1 stop bit ^{*1} | (initial value) |
| 1 | 2 stop bits ^{*2} | |

Notes: 1. In transmission, a single 1 bit (stop bit) is added at the end of a transmit character.
2. In transmission, two 1 bits (stop bits) are added at the end of a transmit character.

In reception, only the first of the received stop bits is checked, irrespective of the STOP bit setting. If the second stop bit is 1 it is treated as a stop bit, but if 0, it is treated as the start bit of the next transmit character.

Bit 2: Multiprocessor mode (MP)

Bit 2 enables or disables the multiprocessor communication function. When the multiprocessor communication function is disabled, the parity settings in the PE and PM bits are invalid. The MP bit setting is only valid in asynchronous mode. When synchronous mode is selected the MP bit should be set to 0. For details on the multiprocessor communication function, see 10.1.6, Multiprocessor Communication Function.

Bit 2

| MP | Description | |
|----|---|-----------------|
| 0 | Multiprocessor communication function disabled* | (initial value) |
| 1 | Multiprocessor communication function enabled* | |

Note: * For the case where 5-bit data is selected, see table 10.11.

Bits 1 and 0: Clock select 1, 0 (CKS1, CKS0)

Bits 1 and 0 choose $\phi/64$, $\phi/16$, $\phi w/2$, or ϕ as the clock source for the baud rate generator.

For the relation between the clock source, bit rate register setting, and baud rate, see 8, Bit rate register (BRR).

| Bit 1 CKS1 | Bit 0 CKS0 | Description | |
|---------------|---------------|---|-----------------|
| 0 | 0 | ϕ clock | (initial value) |
| 0 | 1 | $\phi w/2$ clock ^{*1} / ϕw clock ^{*2} | |
| 1 | 0 | $\phi/16$ clock | |
| 1 | 1 | $\phi/64$ clock | |

- Notes: 1. $\phi w/2$ clock in active (medium-speed/high-speed) mode and sleep mode
 2. ϕw clock in subactive mode and subsleep mode
 3. In subactive or subsleep mode, SCI3 can be operated when CPU clock is $\phi w/2$ only.

10.2.6 Serial control register 3 (SCR3)

| Bit | 7 | 6 | 5 | 4 | 3 | 2 | 1 | 0 |
|---------------|-----|-----|-----|-----|------|------|------|------|
| | TIE | RIE | TE | RE | MPIE | TEIE | CKE1 | CKE0 |
| Initial value | 0 | 0 | 0 | 0 | 0 | 0 | 0 | 0 |
| Read/Write | R/W | R/W | R/W | R/W | R/W | R/W | R/W | R/W |

SCR3 is an 8-bit register for selecting transmit or receive operation, the asynchronous mode clock output, interrupt request enabling or disabling, and the transmit/receive clock source.

SCR3 can be read or written by the CPU at any time.

SCR3 is initialized to H'00 upon reset, and in standby, module standby or watch mode.

Bit 7: Transmit interrupt enable (TIE)

Bit 7 selects enabling or disabling of the transmit data empty interrupt request (TXI) when transmit data is transferred from the transmit data register (TDR) to the transmit shift register (TSR), and bit TDRE in the serial status register (SSR) is set to 1.

TXI can be released by clearing bit TDRE or bit TIE to 0.

Bit 7

| TIE | Description | |
|-----|--|-----------------|
| 0 | Transmit data empty interrupt request (TXI) disabled | (initial value) |
| 1 | Transmit data empty interrupt request (TXI) enabled | |

Bit 6: Receive interrupt enable (RIE)

Bit 6 selects enabling or disabling of the receive data full interrupt request (RXI) and the receive error interrupt request (ERI) when receive data is transferred from the receive shift register (RSR) to the receive data register (RDR), and bit RDRF in the serial status register (SSR) is set to 1.

There are three kinds of receive error: overrun, framing, and parity.

RXI can be released by clearing bit RDRF or the FER, PER, or OER error flag to 0, or by clearing bit RIE to 0.

Bit 6

| RIE | Description | |
|-----|--|-----------------|
| 0 | Receive data full interrupt request (RXI) and receive error interrupt request (ERI) disabled | (initial value) |
| 1 | Receive data full interrupt request (RXI) and receive error interrupt request (ERI) enabled | |

Bit 5: Transmit enable (TE)

Bit 5 selects enabling or disabling of the start of transmit operation.

Bit 5

| TE | Description | |
|----|---|-----------------|
| 0 | Transmit operation disabled ^{*1} (TXD pin is I/O port) | (initial value) |
| 1 | Transmit operation enabled ^{*2} (TXD pin is transmit data pin) | |

Notes: 1. Bit TDRE in SSR is fixed at 1.

2. When transmit data is written to TDR in this state, bit TDR in SSR is cleared to 0 and serial data transmission is started. Be sure to carry out serial mode register (SMR) settings, and setting of bit SPC31 or SPC32 in SPCR, to decide the transmission format before setting bit TE to 1.

Bit 4: Receive enable (RE)

Bit 4 selects enabling or disabling of the start of receive operation.

Bit 4

| RE | Description |
|----|--|
| 0 | Receive operation disabled* ¹ (RXD pin is I/O port) (initial value) |
| 1 | Receive operation enabled* ² (RXD pin is receive data pin) |

Notes: 1. Note that the RDRF, FER, PER, and OER flags in SSR are not affected when bit RE is cleared to 0, and retain their previous state.

2. In this state, serial data reception is started when a start bit is detected in asynchronous mode or serial clock input is detected in synchronous mode. Be sure to carry out serial mode register (SMR) settings to decide the reception format before setting bit RE to 1.

Bit 3: Multiprocessor interrupt enable (MPIE)

Bit 3 selects enabling or disabling of the multiprocessor interrupt request. The MPIE bit setting is only valid when asynchronous mode is selected and reception is carried out with bit MP in SMR set to 1. The MPIE bit setting is invalid when bit COM is set to 1 or bit MP is cleared to 0.

Bit 3

| MPIE | Description |
|------|---|
| 0 | Multiprocessor interrupt request disabled (normal receive operation) (initial value) Clearing conditions: When data is received in which the multiprocessor bit is set to 1 |
| 1 | Multiprocessor interrupt request enabled* |

Note: * Receive data transfer from RSR to RDR, receive error detection, and setting of the RDRF, FER, and OER status flags in SSR is not performed. RXI, ERI, and setting of the RDRF, FER, and OER flags in SSR, are disabled until data with the multiprocessor bit set to 1 is received. When a receive character with the multiprocessor bit set to 1 is received, bit MPBR in SSR is set to 1, bit MPIE is automatically cleared to 0, and RXI and ERI requests (when bits TIE and RIE in serial control register 3 (SCR3) are set to 1) and setting of the RDRF, FER, and OER flags are enabled.

Bit 2: Transmit end interrupt enable (TEIE)

Bit 2 selects enabling or disabling of the transmit end interrupt request (TEI) if there is no valid transmit data in TDR when MSB data is to be sent.

Bit 2

| TEIE | Description |
|------|---|
| 0 | Transmit end interrupt request (TEI) disabled (initial value) |
| 1 | Transmit end interrupt request (TEI) enabled* |

Note: * TEI can be released by clearing bit TDRE to 0 and clearing bit TEND to 0 in SSR, or by clearing bit TEIE to 0.

Bits 1 and 0: Clock enable 1 and 0 (CKE1, CKE0)

Bits 1 and 0 select the clock source and enabling or disabling of clock output from the SCK_{3x} pin. The combination of CKE1 and CKE0 determines whether the SCK_{3x} pin functions as an I/O port, a clock output pin, or a clock input pin.

The CKE0 bit setting is only valid in case of internal clock operation (CKE1 = 0) in asynchronous mode. In synchronous mode, or when external clock operation is used (CKE1 = 1), bit CKE0 should be cleared to 0.

After setting bits CKE1 and CKE0, set the operating mode in the serial mode register (SMR).

For details on clock source selection, see table 10.4 in 10.1.3, Operation.

| Bit 1 | Bit 0 | Description | | |
|-------|-------|--------------------|----------------|-----------------------------------|
| CKE1 | CKE0 | Communication Mode | Clock Source | SCK _{3x} Pin Function |
| 0 | 0 | Asynchronous | Internal clock | I/O port ^{*1} |
| | | Synchronous | Internal clock | Serial clock output ^{*1} |
| 0 | 1 | Asynchronous | Internal clock | Clock output ^{*2} |
| | | Synchronous | Reserved | |
| 1 | 0 | Asynchronous | External clock | Clock input ^{*3} |
| | | Synchronous | External clock | Serial clock input |
| 1 | 1 | Asynchronous | Reserved | |
| | | Synchronous | Reserved | |

Notes: 1. Initial value

2. A clock with the same frequency as the bit rate is output.

3. Input a clock with a frequency 16 times the bit rate.

10.2.7 Serial status register (SSR)

| Bit | 7 | 6 | 5 | 4 | 3 | 2 | 1 | 0 |
|---------------|--------|--------|--------|--------|--------|------|------|------|
| | TDRE | RDRF | OER | FER | PER | TEND | MPBR | MPBT |
| Initial value | 1 | 0 | 0 | 0 | 0 | 1 | 0 | 0 |
| Read/Write | R/(W)* | R/(W)* | R/(W)* | R/(W)* | R/(W)* | R | R | R/W |

Note: * Only a write of 0 for flag clearing is possible.

SSR is an 8-bit register containing status flags that indicate the operational status of SCI3, and multiprocessor bits.

SSR can be read or written by the CPU at any time, but only a write of 1 is possible to bits TDRE, RDRF, OER, PER, and FER. In order to clear these bits by writing 0, 1 must first be read.

Bits TEND and MPBR are read-only bits, and cannot be modified.

SSR is initialized to H'84 upon reset, and in standby, module standby, or watch mode.

Bit 7: Transmit data register empty (TDRE)

Bit 7 indicates that transmit data has been transferred from TDR to TSR.

Bit 7

| TDRE | Description |
|------|--|
| 0 | Transmit data written in TDR has not been transferred to TSR Clearing conditions: After reading TDRE = 1, cleared by writing 0 to TDRE When data is written to TDR by an instruction |
| 1 | Transmit data has not been written to TDR, or transmit data written in TDR has been transferred to TSR Setting conditions: When bit TE in SCR3 is cleared to 0 When data is transferred from TDR to TSR (initial value) |

Bit 6: Receive data register full (RDRF)

Bit 6 indicates that received data is stored in RDR.

Bit 6

RDRF

Description

| 0 | There is no receive data in RDR Clearing conditions: After reading RDRF = 1, cleared by writing 0 to RDRF When RDR data is read by an instruction | (initial value) |
|---|--|-----------------|
| 1 | There is receive data in RDR Setting conditions: When reception ends normally and receive data is transferred from RSR to RDR | |

Note: If an error is detected in the receive data, or if the RE bit in SCR3 has been cleared to 0, RDR and bit RDRF are not affected and retain their previous state.

Note that if data reception is completed while bit RDRF is still set to 1, an overrun error (OER) will result and the receive data will be lost.

Bit 5: Overrun error (OER)

Bit 5 indicates that an overrun error has occurred during reception.

Bit 5

OER

Description

| | | |
|---|---|-----------------|
| 0 | Reception in progress or completed ^{*1} Clearing conditions: After reading OER = 1, cleared by writing 0 to OER | (initial value) |
| 1 | An overrun error has occurred during reception ^{*2} Setting conditions: When reception is completed with RDRF set to 1 | |

Notes: 1. When bit RE in SCR3 is cleared to 0, bit OER is not affected and retains its previous state.

2. RDR retains the receive data it held before the overrun error occurred, and data received after the error is lost. Reception cannot be continued with bit OER set to 1, and in synchronous mode, transmission cannot be continued either.

Bit 4: Framing error (FER)

Bit 4 indicates that a framing error has occurred during reception in asynchronous mode.

Bit 4

| FER | Description |
|-----|---|
| 0 | Reception in progress or completed ^{*1} (initial value) Clearing conditions: After reading FER = 1, cleared by writing 0 to FER |
| 1 | A framing error has occurred during reception Setting conditions: When the stop bit at the end of the receive data is checked for a value of 1 at the end of reception, and the stop bit is 0 ^{*2} |

- Notes:
1. When bit RE in SCR3 is cleared to 0, bit FER is not affected and retains its previous state.
 2. Note that, in 2-stop-bit mode, only the first stop bit is checked for a value of 1, and the second stop bit is not checked. When a framing error occurs the receive data is transferred to RDR but bit RDRF is not set. Reception cannot be continued with bit FER set to 1. In synchronous mode, neither transmission nor reception is possible when bit FER is set to 1.

Bit 3: Parity error (PER)

Bit 3 indicates that a parity error has occurred during reception with parity added in asynchronous mode.

Bit 3

| PER | Description |
|-----|---|
| 0 | Reception in progress or completed ^{*1} (initial value) Clearing conditions: After reading PER = 1, cleared by writing 0 to PER |
| 1 | A parity error has occurred during reception ^{*2} Setting conditions: When the number of 1 bits in the receive data plus parity bit does not match the parity designated by bit PM in the serial mode register (SMR) |

- Notes:
1. When bit RE in SCR3 is cleared to 0, bit PER is not affected and retains its previous state.
 2. Receive data in which a parity error has occurred is still transferred to RDR, but bit RDRF is not set. Reception cannot be continued with bit PER set to 1. In synchronous mode, neither transmission nor reception is possible when bit FER is set to 1.

Bit 2: Transmit end (TEND)

Bit 2 indicates that bit TDRE is set to 1 when the last bit of a transmit character is sent.

Bit 2 is a read-only bit and cannot be modified.

Bit 2

| TEND | Description |
|------|---|
| 0 | Transmission in progress Clearing conditions: After reading TDRE = 1, cleared by writing 0 to TDRE When data is written to TDR by an instruction |
| 1 | Transmission ended (initial value) Setting conditions: When bit TE in SCR3 is cleared to 0 When bit TDRE is set to 1 when the last bit of a transmit character is sent |

Bit 1: Multiprocessor bit receive (MPBR)

Bit 1 stores the multiprocessor bit in a receive character during multiprocessor format reception in asynchronous mode.

Bit 1 is a read-only bit and cannot be modified.

Bit 1

| MPBR | Description |
|------|--|
| 0 | Data in which the multiprocessor bit is 0 has been received* (initial value) |
| 1 | Data in which the multiprocessor bit is 1 has been received |

Note: *When bit RE is cleared to 0 in SCR3 with the multiprocessor format, bit MPBR is not affected and retains its previous state.

Bit 0: Multiprocessor bit transfer (MPBT)

Bit 0 stores the multiprocessor bit added to transmit data when transmitting in asynchronous mode. The bit MPBT setting is invalid when synchronous mode is selected, when the multiprocessor communication function is disabled, and when not transmitting.

Bit 0

| MPBT | Description |
|------|---|
| 0 | A 0 multiprocessor bit is transmitted (initial value) |
| 1 | A 1 multiprocessor bit is transmitted |

10.2.8 Bit rate register (BRR)

| | | | | | | | | |
|---------------|------|------|------|------|------|------|------|------|
| Bit | 7 | 6 | 5 | 4 | 3 | 2 | 1 | 0 |
| | BRR7 | BRR6 | BRR5 | BRR4 | BRR3 | BRR2 | BRR1 | BRR0 |
| Initial value | 1 | 1 | 1 | 1 | 1 | 1 | 1 | 1 |
| Read/Write | R/W | R/W | R/W | R/W | R/W | R/W | R/W | R/W |

BRR is an 8-bit register that designates the transmit/receive bit rate in accordance with the baud rate generator operating clock selected by bits CKS1 and CKS0 of the serial mode register (SMR).

BRR can be read or written by the CPU at any time.

BRR is initialized to H'FF upon reset, and in standby, module standby, or watch mode.

Table 10.3 shows examples of BRR settings in asynchronous mode. The values shown are for active (high-speed) mode.

Table 10.3 Examples of BRR Settings for Various Bit Rates (Asynchronous Mode) (1)

| B Bit Rate (bit/s) | OSC | | | | | | | | | | | | | | |
|-----------------------|-----------------|---|-----------|----------|---|-----------|-------|-----|-----------|------------|-----|-----------|-------|-----|-----------|
| | 32.8 kHz | | | 38.4 kHz | | | 2 MHz | | | 2.4576 MHz | | | 4 MHz | | |
| | n | N | Error (%) | n | N | Error (%) | n | N | Error (%) | n | N | Error (%) | n | N | Error (%) |
| 110 | Cannot be used, | | | — | — | — | — | — | — | 2 | 21 | -0.83 | — | — | — |
| 150 | as error | | | 0 | 3 | 0 | 2 | 12 | 0.16 | 3 | 3 | 0 | 2 | 25 | 0.16 |
| 200 | exceeds 3% | | | 0 | 2 | 0 | 0 | 155 | 0.16 | 3 | 2 | 0 | — | — | — |
| 250 | | | | — | — | — | 0 | 124 | 0 | 0 | 153 | -0.26 | 0 | 249 | 0 |
| 300 | | | | 0 | 1 | 0 | 0 | 103 | 0.16 | 3 | 1 | 0 | 2 | 12 | 0.16 |
| 600 | | | | 0 | 0 | 0 | 0 | 51 | 0.16 | 3 | 0 | 0 | 0 | 103 | 0.16 |
| 1200 | | | | — | — | — | 0 | 25 | 0.16 | 2 | 1 | 0 | 0 | 51 | 0.16 |
| 2400 | | | | — | — | — | 0 | 12 | 0.16 | 2 | 0 | 0 | 0 | 25 | 0.16 |
| 4800 | | | | — | — | — | — | — | — | 0 | 7 | 0 | 0 | 12 | 0.16 |
| 9600 | | | | — | — | — | — | — | — | 0 | 3 | 0 | — | — | — |
| 19200 | | | | — | — | — | — | — | — | 0 | 1 | 0 | — | — | — |
| 31250 | | | | — | — | — | — | — | — | — | — | — | 0 | 1 | 0 |
| 38400 | | | | — | — | — | — | — | — | 0 | 0 | 0 | — | — | — |

Notes: 1. The setting should be made so that the error is not more than 1%.

2. The value set in BRR is given by the following equation:

$$N = \frac{OSC}{(64 \times 2^{2n} \times B)} - 1$$

where

B: Bit rate (bit/s)

N: Baud rate generator BRR setting (0 N 255)

OSC: Value of ϕ_{OSC} (Hz)

n: Baud rate generator input clock number (n = 0, 2, or 3)

(The relation between n and the clock is shown in table 10.4.)

3. The error in table 10.3 is the value obtained from the following equation, rounded to two decimal places.

$$\text{Error (\%)} = \frac{B \text{ (rate obtained from n, N, OSC)} - R \text{ (bit rate in left-hand column in table 10.3.)}}{R \text{ (bit rate in left-hand column in table 10.3.)}} \times 100$$

Table 10.4 Relation between n and Clock

| n | Clock | SMR Setting | |
|---|-----------------------------|-------------|------|
| | | CKS1 | CKS0 |
| 0 | ϕ | 0 | 0 |
| 0 | $\phi_w/2^{*1}/\phi_w^{*2}$ | 0 | 1 |
| 2 | $\phi/16$ | 1 | 0 |
| 3 | $\phi/64$ | 1 | 1 |

Notes: 1. $\phi_w/2$ clock in active (medium-speed/high-speed) mode and sleep mode

2. ϕ_w clock in subactive mode and subsleep mode

3. In subactive or subsleep mode, SCI3 can be operated when CPU clock is $\phi_w/2$ only.

Table 10.5 shows the maximum bit rate for each frequency. The values shown are for active (high-speed) mode.

Table 10.5 Maximum Bit Rate for Each Frequency (Asynchronous Mode)

| OSC (MHz) | Maximum Bit Rate (bit/s) | Setting | |
|-----------|-----------------------------|---------|---|
| | | n | N |
| 0.0384* | 600 | 0 | 0 |
| 2 | 31250 | 0 | 0 |
| 2.4576 | 38400 | 0 | 0 |
| 4 | 62500 | 0 | 0 |

* : When SMR is set up to CKS1 = "0", CKS0 = "1".

Table 10.6 shows examples of BRR settings in synchronous mode. The values shown are for active (high-speed) mode.

Table 10.6 Examples of BRR Settings for Various Bit Rates (Synchronous Mode)

| B Bit Rate (bit/s) | OSC | | | | | | | | |
|-----------------------|----------|----|-------|-------|-----|-------|-------|-----|-------|
| | 38.4 kHz | | | 2 MHz | | | 4 MHz | | |
| | n | N | Error | n | N | Error | n | N | Error |
| 200 | 0 | 23 | 0 | — | — | — | — | — | — |
| 250 | — | — | — | — | — | — | 2 | 124 | 0 |
| 300 | 2 | 0 | 0 | — | — | — | — | — | — |
| 500 | — | — | — | — | — | — | — | — | — |
| 1k | — | — | — | 0 | 249 | 0 | — | — | — |
| 2.5k | — | — | — | 0 | 99 | 0 | 0 | 199 | 0 |
| 5k | — | — | — | 0 | 49 | 0 | 0 | 99 | 0 |
| 10k | — | — | — | 0 | 24 | 0 | 0 | 49 | 0 |
| 25k | — | — | — | 0 | 9 | 0 | 0 | 19 | 0 |
| 50k | — | — | — | 0 | 4 | 0 | 0 | 9 | 0 |
| 100k | — | — | — | — | — | — | 0 | 4 | 0 |
| 250k | — | — | — | 0 | 0 | 0 | 0 | 1 | 0 |
| 500k | — | — | — | — | — | — | 0 | 0 | 0 |
| 1M | — | — | — | — | — | — | — | — | — |

Blank: Cannot be set.

— : A setting can be made, but an error will result.

Notes: The value set in BRR is given by the following equation:

$$N = \frac{OSC}{(8 \times 2^{2n} \times B)} - 1$$

where

B: Bit rate (bit/s)

N: Baud rate generator BRR setting (0 N 255)

OSC: Value of ϕ_{OSC} (Hz)

n: Baud rate generator input clock number (n = 0, 2, or 3)

(The relation between n and the clock is shown in table 10.7.)

Table 10.7 Relation between n and Clock

| n | Clock | SMR Setting | |
|---|-----------------------------|-------------|------|
| | | CKS1 | CKS0 |
| 0 | ϕ | 0 | 0 |
| 0 | $\phi_w/2^{*1}/\phi_w^{*2}$ | 0 | 1 |
| 2 | $\phi/16$ | 1 | 0 |
| 3 | $\phi/64$ | 1 | 1 |

- Notes:
1. $\phi_w/2$ clock in active (medium-speed/high-speed) mode and sleep mode
 2. ϕ_w clock in subactive mode and subsleep mode
 3. In subactive or subsleep mode, SCI3 can be operated when CPU clock is $\phi_w/2$ only.

10.2.9 Clock stop register 1 (CKSTPR1)

| | | | | | | | | |
|---------------|-----|----------|----------|---------|---------|---------|---------|---------|
| Bit | 7 | 6 | 5 | 4 | 3 | 2 | 1 | 0 |
| | — | S31CKSTP | S32CKSTP | ADCKSTP | TGCKSTP | TFCKSTP | TCCKSTP | TACKSTP |
| Initial value | 1 | 1 | 1 | 1 | 1 | 1 | 1 | 1 |
| Read/Write | R/W | R/W | R/W | R/W | R/W | R/W | R/W | R/W |

CKSTPR1 is an 8-bit read/write register that performs module standby mode control for peripheral modules. Only the bits relating to SCI3 are described here. For details of the other bits, see the sections on the relevant modules.

Bit 6: SCI3-1 module standby mode control (S31CKSTP)

Bit 6 controls setting and clearing of module standby mode for SCI31.

| S31CKSTP | Description |
|----------|-------------|
|----------|-------------|

| | |
|---|---|
| 0 | SCI3-1 is set to module standby mode |
| 1 | SCI3-1 module standby mode is cleared (initial value) |

Note: All SCI31 register is initialized in module standby mode.

Bit 5: SCI3-2 module standby mode control (S32CKSTP)

Bit 5 controls setting and clearing of module standby mode for SCI32.

| S32CKSTP | Description |
|----------|-------------|
|----------|-------------|

| | |
|---|---|
| 0 | SCI3-2 is set to module standby mode |
| 1 | SCI3-2 module standby mode is cleared (initial value) |

Note: All SCI32 register is initialized in module standby mode.

10.2.10 Serial Port Control Register (SPCR)

| | | | | | | | | |
|---------------|---|---|-------|-------|--------|--------|--------|--------|
| Bit | 7 | 6 | 5 | 4 | 3 | 2 | 1 | 0 |
| | — | — | SPC32 | SPC31 | SCINV3 | SCINV2 | SCINV1 | SCINV0 |
| Initial value | 1 | 1 | 0 | 0 | 0 | 0 | 0 | 0 |
| Read/Write | — | — | R/W | R/W | R/W | R/W | R/W | R/W |

SPCR is an 8-bit readable/writable register that performs RXD₃₁, RXD₃₂, TXD₃₁, and TXD₃₂ pin input/output data inversion switching. SPCR is initialized to H'C0 by a reset.

Bit 0: RXD₃₁ pin input data inversion switch

Bit 0 specifies whether or not RXD₃₁ pin input data is to be inverted.

Bit 0

| SCINV0 | Description |
|--------|--|
| 0 | RXD ₃₁ input data is not inverted (initial value) |
| 1 | RXD ₃₁ input data is inverted |

Bit 1: TXD₃₁ pin output data inversion switch

Bit 1 specifies whether or not TXD₃₁ pin output data is to be inverted.

Bit 1

| SCINV1 | Description |
|--------|---|
| 0 | TXD ₃₁ output data is not inverted (initial value) |
| 1 | TXD ₃₁ output data is inverted |

Bit 2: RXD₃₂ pin input data inversion switch

Bit 2 specifies whether or not RXD₃₂ pin input data is to be inverted.

Bit 2

| SCINV2 | Description |
|--------|--|
| 0 | RXD ₃₂ input data is not inverted (initial value) |
| 1 | RXD ₃₂ input data is inverted |

Bit 3: TXD₃₂ pin output data inversion switch

Bit 3 specifies whether or not TXD₃₂ pin output data is to be inverted.

Bit 3**SCINV3****Description**

| | Description | |
|---|---|-----------------|
| 0 | TXD ₃₂ output data is not inverted | (initial value) |
| 1 | TXD ₃₂ output data is inverted | |

Bit 4: P3₅/TXD₃₁ pin function switch (SPC31)

This bit selects whether pin P3₅/TXD₃₁ is used as P3₅ or as TXD₃₁.

Bit 4**SPC31****Description**

| | Description | |
|---|--|-----------------|
| 0 | Functions as P3 ₅ I/O pin | (initial value) |
| 1 | Functions as TXD ₃₁ output pin* | |

Note: * Set the TE bit in SCR3 after setting this bit to 1.

Bit 5: P4₂/TXD₃₂ pin function switch (SPC32)

This bit selects whether pin P4₂/TXD₃₂ is used as P4₂ or as TXD₃₂.

Bit 5**SPC32****Description**

| | Description | |
|---|--|-----------------|
| 0 | Functions as P4 ₂ I/O pin | (initial value) |
| 1 | Functions as TXD ₃₂ output pin* | |

Note: * Set the TE bit in SCR3 after setting this bit to 1.

Bits 7 to 6: Reserved bits

Bits 7 to 6 are reserved; they are always read as 1 and cannot be modified.

10.3 Operation

10.3.1 Overview

SCI3 can perform serial communication in two modes: asynchronous mode in which synchronization is provided character by character, and synchronous mode in which synchronization is provided by clock pulses. The serial mode register (SMR) is used to select asynchronous or synchronous mode and the data transfer format, as shown in table 10.8.

The clock source for SCI3 is determined by bit COM in SMR and bits CKE1 and CKE0 in SCR3, as shown in table 10.9.

1. Synchronous mode

- Choice of 5-, 7-, or 8-bit data length
- Choice of parity addition, multiprocessor bit addition, and addition of 1 or 2 stop bits. (The combination of these parameters determines the data transfer format and the character length.)
- Framing error (FER), parity error (PER), overrun error (OER), and break detection during reception
- Choice of internal or external clock as the clock source

When internal clock is selected: SCI3 operates on the baud rate generator clock, and a clock with the same frequency as the bit rate can be output.

When external clock is selected: A clock with a frequency 16 times the bit rate must be input. (The on-chip baud rate generator is not used.)

2. Synchronous mode

- Data transfer format: Fixed 8-bit data length
- Overrun error (OER) detection during reception
- Choice of internal or external clock as the clock source

When internal clock is selected: SCI3 operates on the baud rate generator clock, and a serial clock is output.

When external clock is selected: The on-chip baud rate generator is not used, and SCI3 operates on the input serial clock.

Table 10.8 SMR Settings and Corresponding Data Transfer Formats

| SMR | | | | | Data Transfer Format | | | | | | | |
|--------------|--------------|-------------|-------------|----------------------|----------------------|----------------|-----------------------|---------------|--------------------|------------|-------|-------|
| bit 7 COM | bit 6 CHR | bit 2 MP | bit 5 PE | bit 3 STOP | Mode | Data Length | Multiprocessor Bit | Parity Bit | Stop Bit Length | | | |
| 0 | 0 | 0 | 0 | 0 | Asynchronous mode | 8-bit data | No | No | 1 bit | | | |
| | | | | 1 | | | | | 2 bits | | | |
| | | | | 0 | | | | | 1 bit | | | |
| | | | | 1 | | | | | 2 bits | | | |
| | | | | 0 | | | | | 1 bit | | | |
| | | | | 1 | | | | | 2 bits | | | |
| | 1 | 0 | 0 | 0 | 7-bit data | 7-bit data | | | 1 bit | | | |
| | | | | 1 | | | | | 2 bits | | | |
| | | | | 0 | | | | | 1 bit | | | |
| | | | | 1 | | | | | 2 bits | | | |
| | | | | 0 | | | | | 1 bit | | | |
| | | | | 1 | | | | | 2 bits | | | |
| 0 | 1 | 0 | 0 | Asynchronous mode | 8-bit data | Yes | No | 1 bit | | | | |
| | | | 1 | | | | | 2 bits | | | | |
| | | | 1 | | | | | 0 | 5-bit data | No | 1 bit | |
| | | | 1 | | | | | 2 bits | | | | |
| | | | 0 | | | | | 1 bit | | | | |
| | | | 1 | | | | | 2 bits | | | | |
| | 0 | 1 bit | | | | | | | | | | |
| | 1 | 2 bits | | | | | | | | | | |
| | 1 | 0 | 0 | 0 | 7-bit data | 7-bit data | Yes | | 1 bit | | | |
| | | | | 1 | | | | | 2 bits | | | |
| | | | | 1 | | | | | 0 | 5-bit data | No | 1 bit |
| | | | | 1 | | | | | 2 bits | | | |
| 0 | | | | 1 bit | | | | | | | | |
| 1 | | | | 2 bits | | | | | | | | |
| 0 | 1 bit | | | | | | | | | | | |
| 1 | 2 bits | | | | | | | | | | | |
| 1 | * | 0 | * | * | Synchronous mode | 8-bit data | No | No | No | | | |

*: Don't care

Table 10.9 SMR and SCR3 Settings and Clock Source Selection

| SMR | | SCR3 | | Mode | Transmit/Receive Clock | |
|-------|-------|-------|--|--|---|---------------------|
| bit 7 | bit 1 | bit 0 | Clock Source | | SCK _{3x} | Pin Function |
| 0 | 0 | 0 | Asynchronous mode | Internal | I/O port (SCK _{3x} pin not used) | |
| | | 1 | | | Outputs clock with same frequency as bit rate | |
| | 1 | 0 | External | Outputs clock with frequency 16 times bit rate | | |
| 1 | 0 | 0 | Synchronous mode | Internal | Outputs serial clock | |
| | 1 | 0 | | | External | Inputs serial clock |
| 0 | 1 | 1 | Reserved (Do not specify these combinations) | | | |
| 1 | 0 | 1 | | | | |
| 1 | 1 | 1 | | | | |

3. Interrupts and continuous transmission/reception

SCI3 can carry out continuous reception using RXI and continuous transmission using TXI. These interrupts are shown in table 10.10.

Table 10.10 Transmit/Receive Interrupts

| Interrupt | Flags | Interrupt Request Conditions | Notes |
|-----------|--------------|---|---|
| RXI | RDRF RIE | When serial reception is performed normally and receive data is transferred from RSR to RDR, bit RDRF is set to 1, and if bit RIE is set to 1 at this time, RXI is enabled and an interrupt is requested. (See figure 10.2 (a).) | The RXI interrupt routine reads the receive data transferred to RDR and clears bit RDRF to 0. Continuous reception can be performed by repeating the above operations until reception of the next RSR data is completed. |
| TXI | TDRE TIE | When TSR is found to be empty (on completion of the previous transmission) and the transmit data placed in TDR is transferred to TSR, bit TDRE is set to 1. If bit TIE is set to 1 at this time, TXI is enabled and an interrupt is requested. (See figure 10.2 (b).) | The TXI interrupt routine writes the next transmit data to TDR and clears bit TDRE to 0. Continuous transmission can be performed by repeating the above operations until the data transferred to TSR has been transmitted. |
| TEI | TEND TEIE | When the last bit of the character in TSR is transmitted, if bit TDRE is set to 1, bit TEND is set to 1. If bit TEIE is set to 1 at this time, TEI is enabled and an interrupt is requested. (See figure 10.2 (c).) | TEI indicates that the next transmit data has not been written to TDR when the last bit of the transmit character in TSR is sent. |

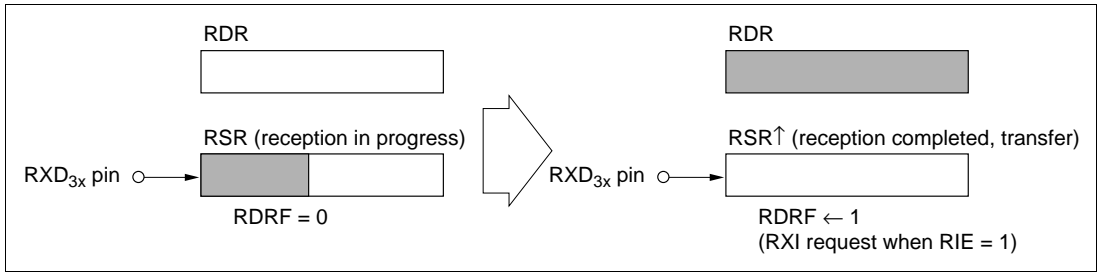

Figure 10.2 (a) RDRF Setting and RXI Interrupt

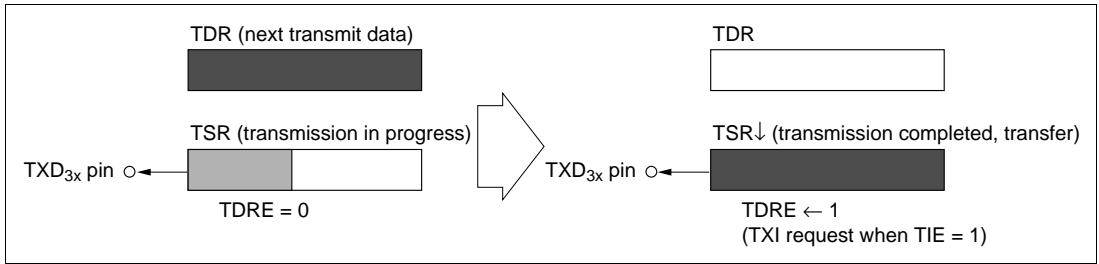

Figure 10.2 (b) TDRE Setting and TXI Interrupt

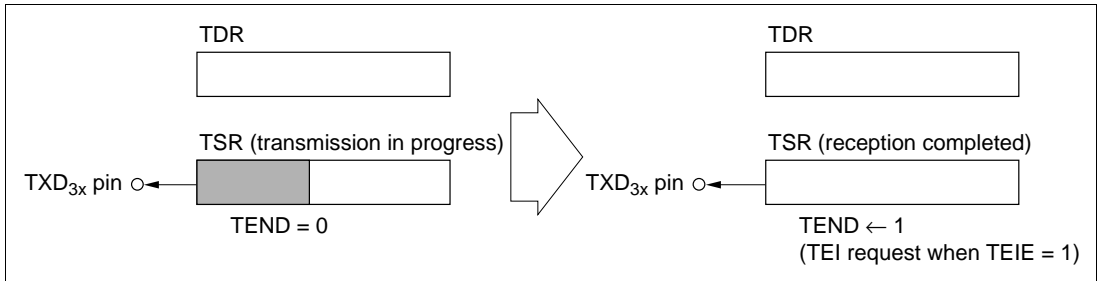

Figure 10.2 (c) TEND Setting and TEI Interrupt

10.3.2 Operation in Asynchronous Mode

In asynchronous mode, serial communication is performed with synchronization provided character by character. A start bit indicating the start of communication and one or two stop bits indicating the end of communication are added to each character before it is sent.

SCI3 has separate transmission and reception units, allowing full-duplex communication. As the transmission and reception units are both double-buffered, data can be written during transmission and read during reception, making possible continuous transmission and reception.

1. Data transfer format

The general data transfer format in asynchronous communication is shown in figure 10.3.

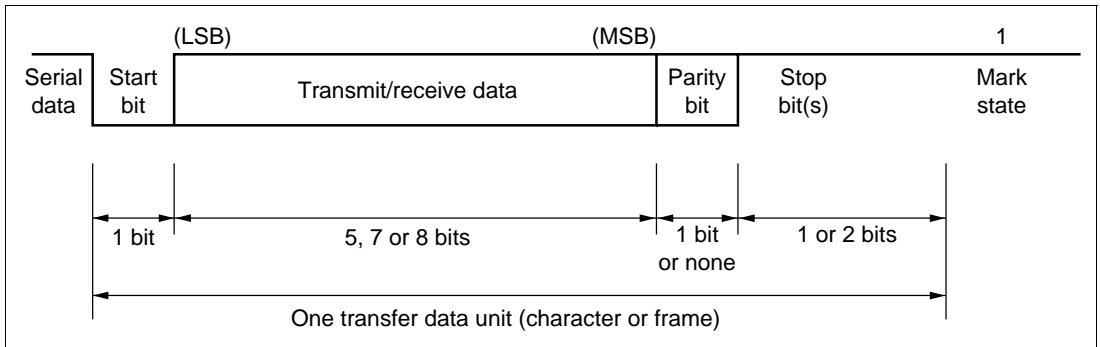

Figure 10.3 Data Format in Asynchronous Communication

In asynchronous communication, the communication line is normally in the mark state (high level). SCI3 monitors the communication line and when it detects a space (low level), identifies this as a start bit and begins serial data communication.

One transfer data character consists of a start bit (low level), followed by transmit/receive data (LSB-first format, starting from the least significant bit), a parity bit (high or low level), and finally one or two stop bits (high level).

In asynchronous mode, synchronization is performed by the falling edge of the start bit during reception. The data is sampled on the 8th pulse of a clock with a frequency 16 times the bit period, so that the transfer data is latched at the center of each bit.

Table 10.11 shows the 12 data transfer formats that can be set in asynchronous mode. The format is selected by the settings in the serial mode register (SMR).

Table 10.11 Data Transfer Formats (Asynchronous Mode)

| SMR | | | | Serial Data Transfer Format and Frame Length | | | | | | | | | | | | | |
|-----|----|----|------|--|------------|---|---|---|---|------|------|------|------|------|------|--|--|
| CHR | PE | MP | STOP | 1 | 2 | 3 | 4 | 5 | 6 | 7 | 8 | 9 | 10 | 11 | 12 | | |
| 0 | 0 | 0 | 0 | S | 8-bit data | | | | | | | | STOP | | | | |
| 0 | 0 | 0 | 1 | S | 8-bit data | | | | | | | | STOP | STOP | | | |
| 0 | 0 | 1 | 0 | S | 8-bit data | | | | | | | | MPB | STOP | | | |
| 0 | 0 | 1 | 1 | S | 8-bit data | | | | | | | | MPB | STOP | STOP | | |
| 0 | 1 | 0 | 0 | S | 8-bit data | | | | | | | | P | STOP | | | |
| 0 | 1 | 0 | 1 | S | 8-bit data | | | | | | | | P | STOP | STOP | | |
| 0 | 1 | 1 | 0 | S | 5-bit data | | | | | STOP | | | | | | | |
| 0 | 1 | 1 | 1 | S | 5-bit data | | | | | STOP | STOP | | | | | | |
| 1 | 0 | 0 | 0 | S | 7-bit data | | | | | | STOP | | | | | | |
| 1 | 0 | 0 | 1 | S | 7-bit data | | | | | | STOP | STOP | | | | | |
| 1 | 0 | 1 | 0 | S | 7-bit data | | | | | | MPB | STOP | | | | | |
| 1 | 0 | 1 | 1 | S | 7-bit data | | | | | | MPB | STOP | STOP | | | | |
| 1 | 1 | 0 | 0 | S | 7-bit data | | | | | | P | STOP | | | | | |
| 1 | 1 | 0 | 1 | S | 7-bit data | | | | | | P | STOP | STOP | | | | |
| 1 | 1 | 1 | 0 | S | 5-bit data | | | | | P | STOP | | | | | | |
| 1 | 1 | 1 | 1 | S | 5-bit data | | | | | P | STOP | STOP | | | | | |

Notation:

- S: Start bit
- STOP: Stop bit
- P: Parity bit
- MPB: Multiprocessor bit

2. Clock

Either an internal clock generated by the baud rate generator or an external clock input at the SCK_{3x} pin can be selected as the SCI3 transmit/receive clock. The selection is made by means of bit COM in SMR and bits SCE1 and CKE0 in SCR3. See table 10.9 for details on clock source selection.

When an external clock is input at the SCK_{3x} pin, the clock frequency should be 16 times the bit rate.

When SCI3 operates on an internal clock, the clock can be output at the SCK_{3x} pin. In this case the frequency of the output clock is the same as the bit rate, and the phase is such that the clock rises at the center of each bit of transmit/receive data, as shown in figure 10.4.

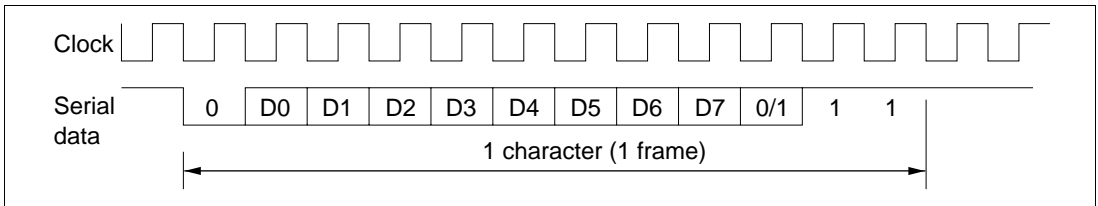

Figure 10.4 Phase Relationship between Output Clock and Transfer Data (Asynchronous Mode) (8-bit data, parity, 2 stop bits)

3. Data transfer operations

- SCI3 initialization

Before data is transferred on SCI3, bits TE and RE in SCR3 must first be cleared to 0, and then SCI3 must be initialized as follows.

Note: If the operation mode or data transfer format is changed, bits TE and RE must first be cleared to 0.

When bit TE is cleared to 0, bit TDRE is set to 1.

Note that the RDRF, PER, FER, and OER flags and the contents of RDR are retained when RE is cleared to 0.

When an external clock is used in asynchronous mode, the clock should not be stopped during operation, including initialization. When an external clock is used in synchronous mode, the clock should not be supplied during operation, including initialization.

Figure 10.5 shows an example of a flowchart for initializing SCI3.

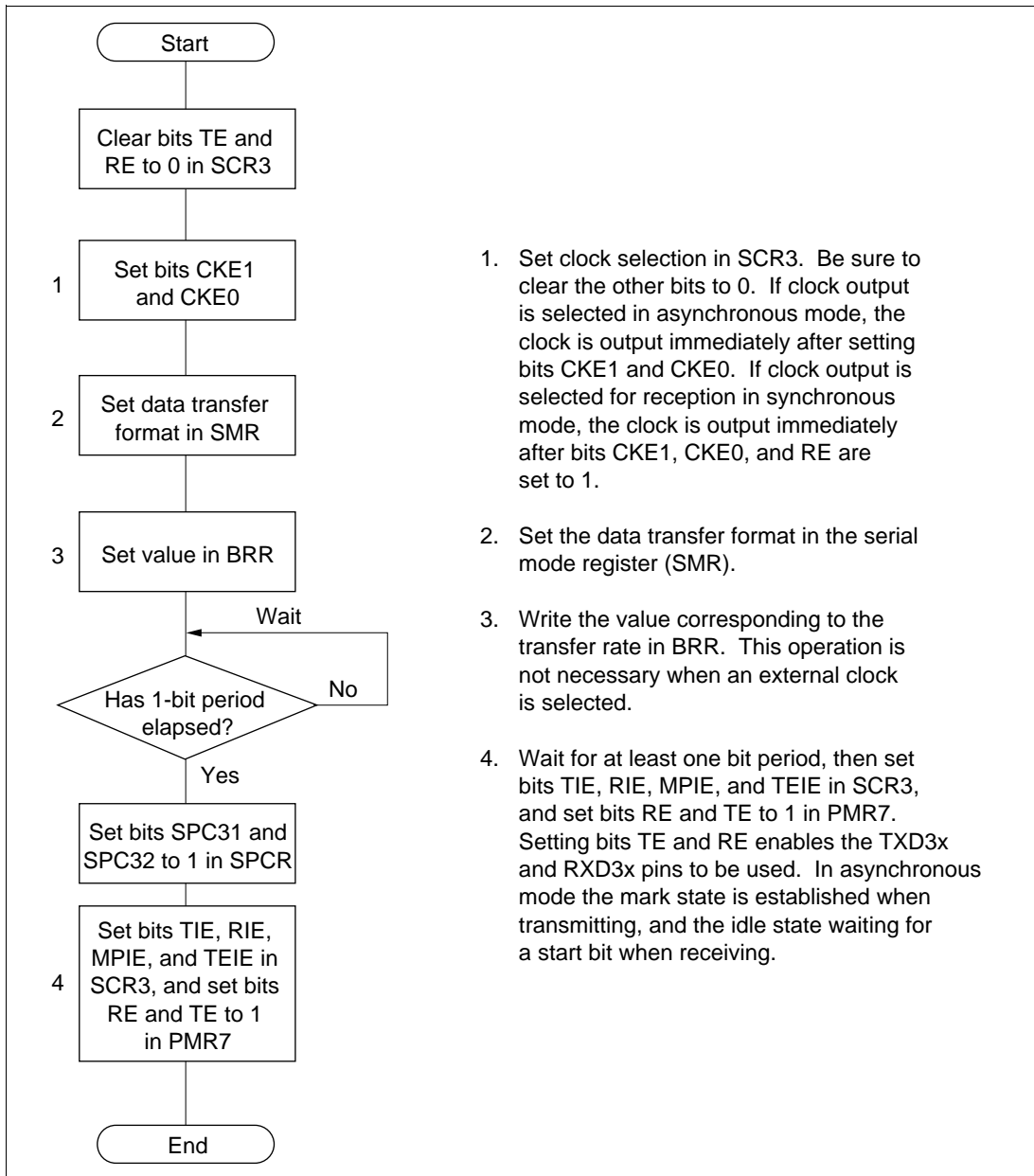
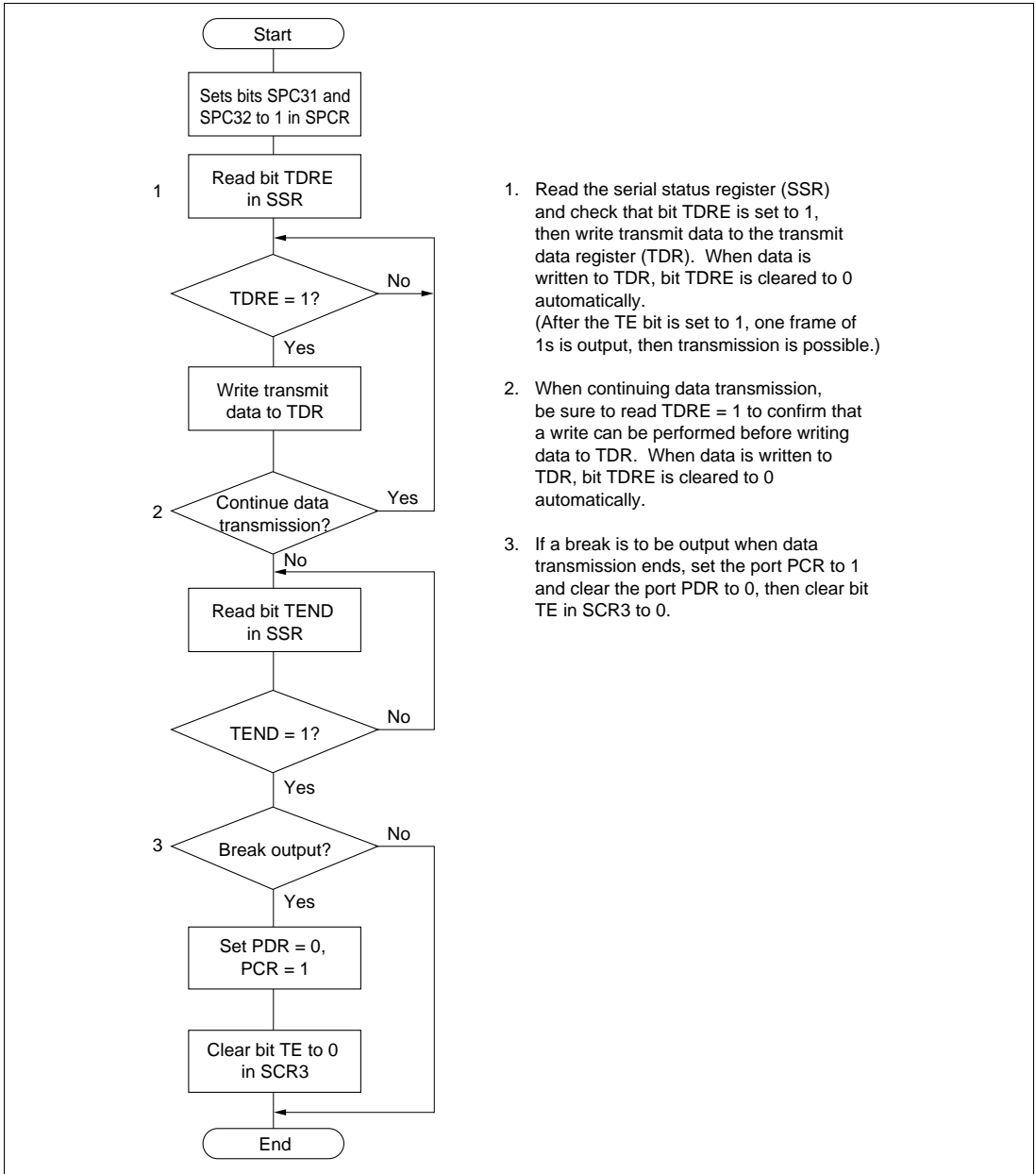

Figure 10.5 Example of SCI3 Initialization Flowchart

- Transmitting

Figure 10.6 shows an example of a flowchart for data transmission. This procedure should be followed for data transmission after initializing SCI3.



1. Read the serial status register (SSR) and check that bit TDRE is set to 1, then write transmit data to the transmit data register (TDR). When data is written to TDR, bit TDRE is cleared to 0 automatically. (After the TE bit is set to 1, one frame of 1s is output, then transmission is possible.)
2. When continuing data transmission, be sure to read TDRE = 1 to confirm that a write can be performed before writing data to TDR. When data is written to TDR, bit TDRE is cleared to 0 automatically.
3. If a break is to be output when data transmission ends, set the port PCR to 1 and clear the port PDR to 0, then clear bit TE in SCR3 to 0.

Figure 10.6 Example of Data Transmission Flowchart (Asynchronous Mode)

SCI3 operates as follows when transmitting data.

SCI3 monitors bit TDRE in SSR, and when it is cleared to 0, recognizes that data has been written to TDR and transfers data from TDR to TSR. It then sets bit TDRE to 1 and starts transmitting. If bit TIE in SCR3 is set to 1 at this time, a TXI request is made.

Serial data is transmitted from the TXD3x pin using the relevant data transfer format in table 10.11. When the stop bit is sent, SCI3 checks bit TDRE. If bit TDRE is cleared to 0, SCI3 transfers data from TDR to TSR, and when the stop bit has been sent, starts transmission of the next frame. If bit TDRE is set to 1, bit TEND in SSR bit is set to 1 the mark state, in which 1s are transmitted, is established after the stop bit has been sent. If bit TEIE in SCR3 is set to 1 at this time, a TEI request is made.

Figure 10.12 shows an example of the operation when transmitting in asynchronous mode.

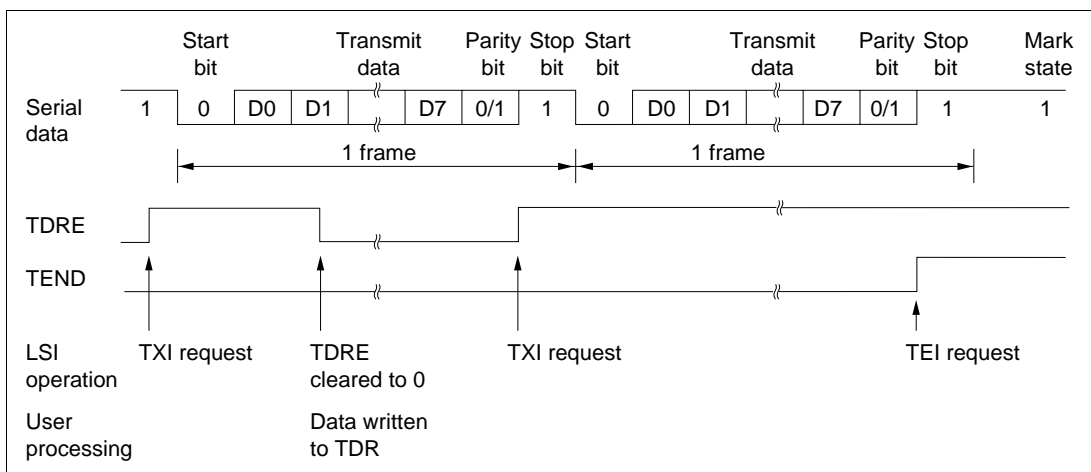

Figure 10.7 Example of Operation when Transmitting in Asynchronous Mode (8-bit data, parity, 1 stop bit)

- Receiving

Figure 10.8 shows an example of a flowchart for data reception. This procedure should be followed for data reception after initializing SCI3.

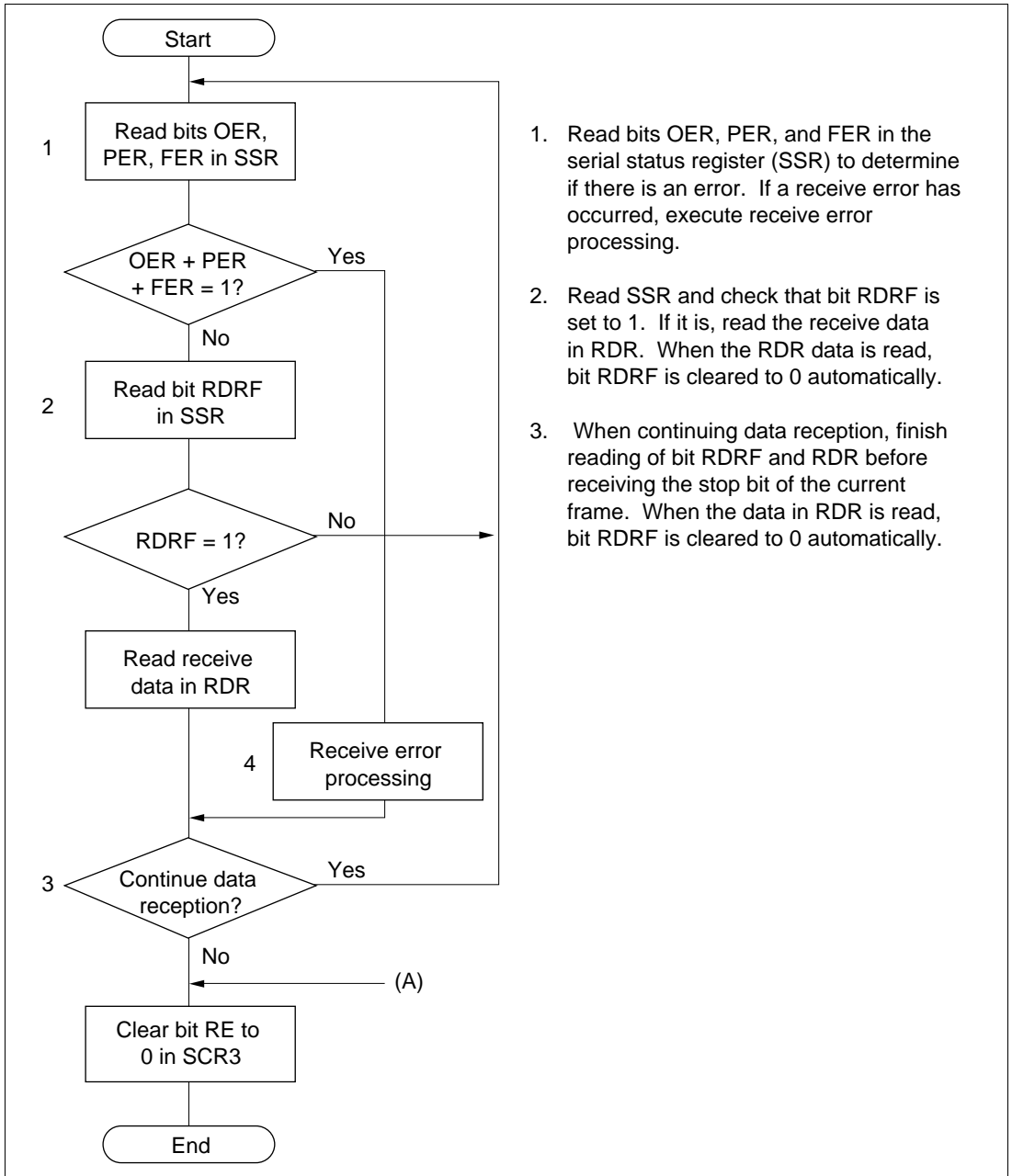

Figure 10.8 Example of Data Reception Flowchart (Asynchronous Mode)

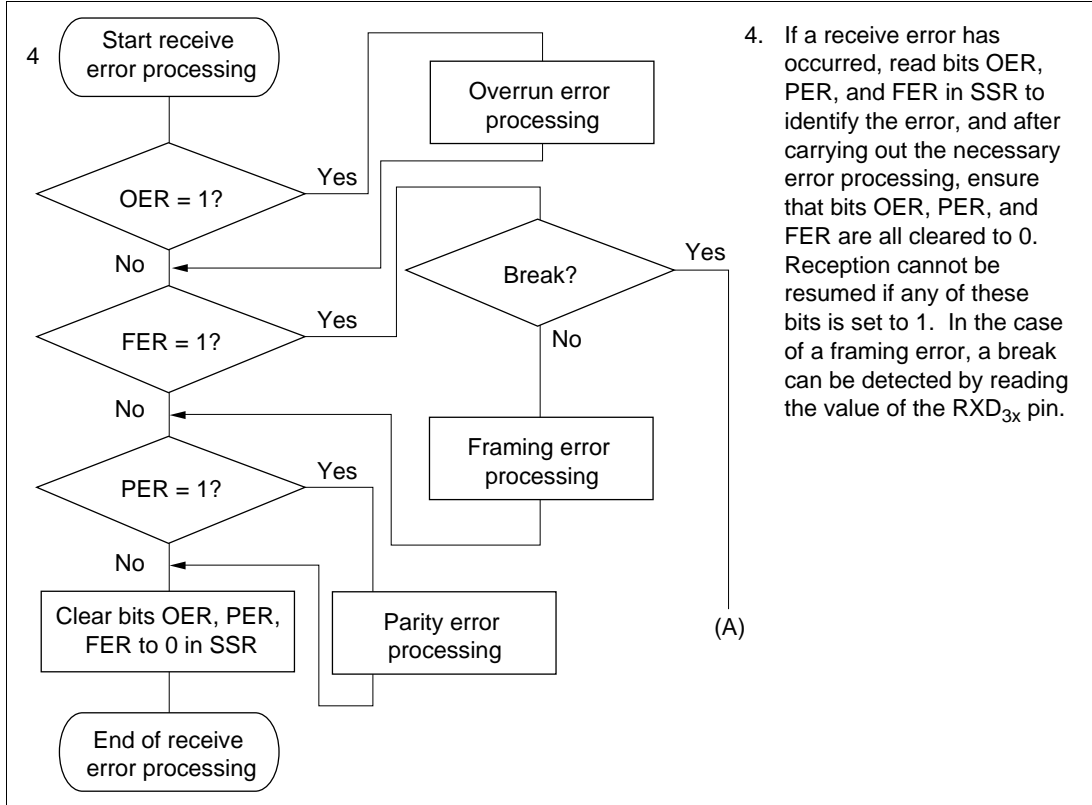

Figure 10.8 Example of Data Reception Flowchart (Asynchronous Mode) (cont)

SCI3 operates as follows when receiving data.

SCI3 monitors the communication line, and when it detects a 0 start bit, performs internal synchronization and begins reception. Reception is carried out in accordance with the relevant data transfer format in table 10.11. The received data is first placed in RSR in LSB-to-MSB order, and then the parity bit and stop bit(s) are received. SCI3 then carries out the following checks.

- Parity check
SCI3 checks that the number of 1 bits in the receive data conforms to the parity (odd or even) set in bit PM in the serial mode register (SMR).
- Stop bit check
SCI3 checks that the stop bit is 1. If two stop bits are used, only the first is checked.
- Status check
SCI3 checks that bit RDRF is set to 0, indicating that the receive data can be transferred from RSR to RDR.

If no receive error is found in the above checks, bit RDRF is set to 1, and the receive data is stored in RDR. If bit RIE is set to 1 in SCR3, an RXI interrupt is requested. If the error checks identify a receive error, bit OER, PER, or FER is set to 1 depending on the kind of error. Bit RDRF retains its state prior to receiving the data. If bit RIE is set to 1 in SCR3, an ERI interrupt is requested.

Table 10.12 shows the conditions for detecting a receive error, and receive data processing.

Note: No further receive operations are possible while a receive error flag is set. Bits OER, FER, PER, and RDRF must therefore be cleared to 0 before resuming reception.

Table 10.12 Receive Error Detection Conditions and Receive Data Processing

| Receive Error | Abbreviation | Detection Conditions | Receive Data Processing |
|---------------|--------------|---|---|
| Overrun error | OER | When the next data receive operation is completed while bit RDRF is still set to 1 in SSR | Receive data is not transferred from RSR to RDR |
| Framing error | FER | When the stop bit is 0 | Receive data is transferred from RSR to RDR |
| Parity error | PER | When the parity (odd or even) set in SMR is different from that of the received data | Receive data is transferred from RSR to RDR |

Figure 10.9 shows an example of the operation when receiving in asynchronous mode.

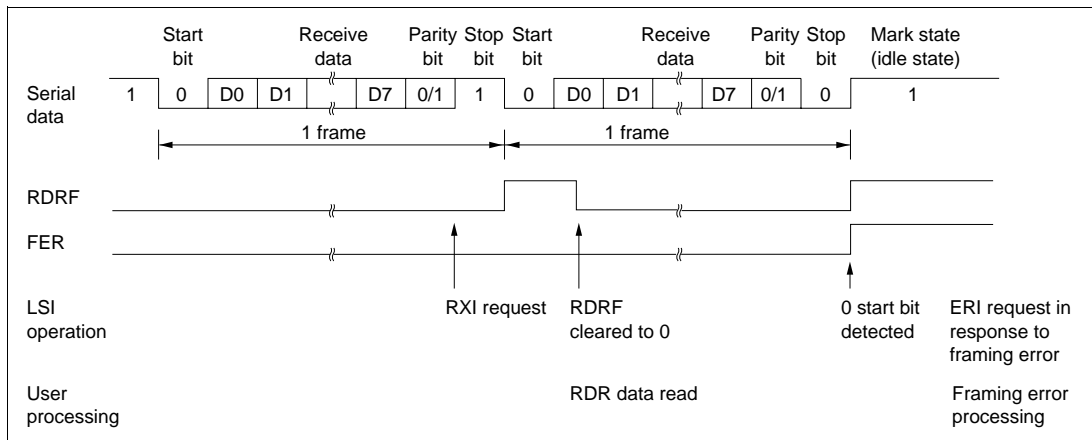

Figure 10.9 Example of Operation when Receiving in Asynchronous Mode (8-bit data, parity, 1 stop bit)

10.3.3 Operation in Synchronous Mode

In synchronous mode, SCI3 transmits and receives data in synchronization with clock pulses. This mode is suitable for high-speed serial communication.

SCI3 has separate transmission and reception units, allowing full-duplex communication with a shared clock.

As the transmission and reception units are both double-buffered, data can be written during transmission and read during reception, making possible continuous transmission and reception.

1. Data transfer format

The general data transfer format in asynchronous communication is shown in figure 10.10.

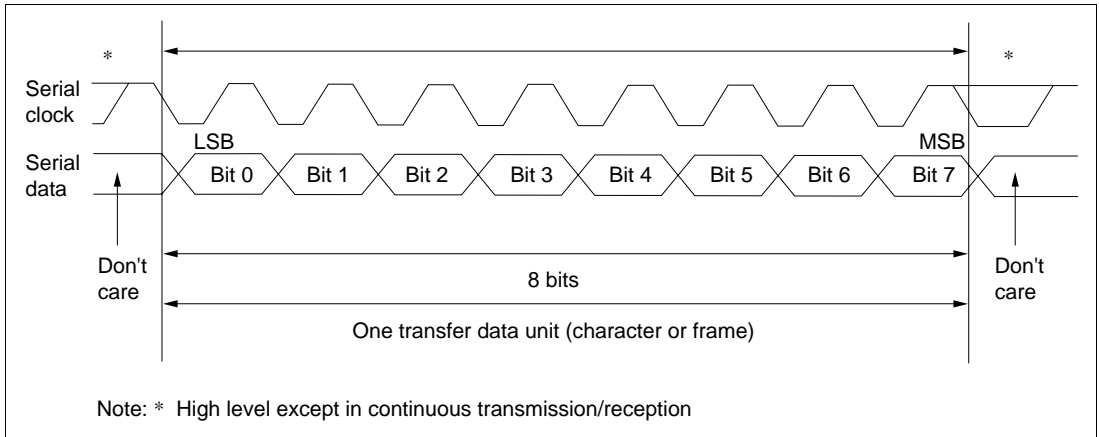

Figure 10.10 Data Format in Synchronous Communication

In synchronous communication, data on the communication line is output from one falling edge of the serial clock until the next falling edge. Data confirmation is guaranteed at the rising edge of the serial clock.

One transfer data character begins with the LSB and ends with the MSB. After output of the MSB, the communication line retains the MSB state.

When receiving in synchronous mode, SCI3 latches receive data at the rising edge of the serial clock.

The data transfer format uses a fixed 8-bit data length.

Parity and multiprocessor bits cannot be added.

2. Clock

Either an internal clock generated by the baud rate generator or an external clock input at the SCK_{3x} pin can be selected as the SCI3 serial clock. The selection is made by means of bit COM in SMR and bits CKE1 and CKE0 in SCR3. See table 10.9 for details on clock source selection.

When SCI3 operates on an internal clock, the serial clock is output at the SCK_{3x} pin. Eight pulses of the serial clock are output in transmission or reception of one character, and when SCI3 is not transmitting or receiving, the clock is fixed at the high level.

3. Data transfer operations

- SCI3 initialization

Data transfer on SCI3 first of all requires that SCI3 be initialized as described in 10.1.4 (3)(a). SCI3 initialization, and shown in figure 10.5.

- Transmitting

Figure 10.11 shows an example of a flowchart for data transmission. This procedure should be followed for data transmission after initializing SCI3.

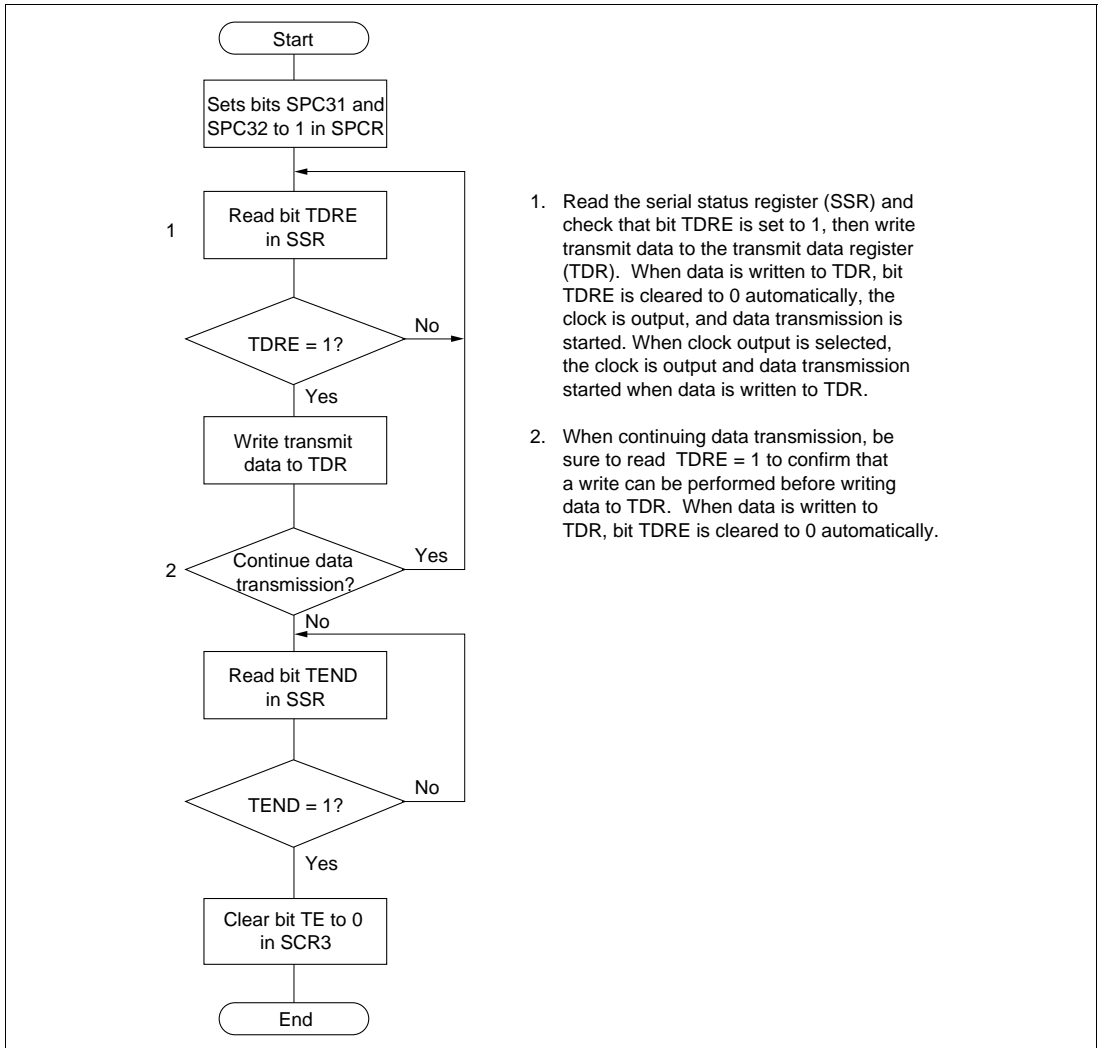

Figure 10.11 Example of Data Transmission Flowchart (Synchronous Mode)

SCI3 operates as follows when transmitting data.

SCI3 monitors bit TDRE in SSR, and when it is cleared to 0, recognizes that data has been written to TDR and transfers data from TDR to TSR. It then sets bit TDRE to 1 and starts transmitting. If bit TIE in SCR3 is set to 1 at this time, a TXI request is made.

When clock output mode is selected, SCI3 outputs 8 serial clock pulses. When an external clock is selected, data is output in synchronization with the input clock.

Serial data is transmitted from the TXD3x pin in order from the LSB (bit 0) to the MSB (bit 7). When the MSB (bit 7) is sent, checks bit TDRE. If bit TDRE is cleared to 0, SCI3 transfers data from TDR to TSR, and starts transmission of the next frame. If bit TDRE is set to 1, SCI3 sets bit TEND to 1 in SSR, and after sending the MSB (bit 7), retains the MSB state. If bit TEIE in SCR3 is set to 1 at this time, a TEI request is made.

After transmission ends, the SCK pin is fixed at the high level.

Note: Transmission is not possible if an error flag (OER, FER, or PER) that indicates the data reception status is set to 1. Check that these error flags are all cleared to 0 before a transmit operation.

Figure 10.12 shows an example of the operation when transmitting in synchronous mode.

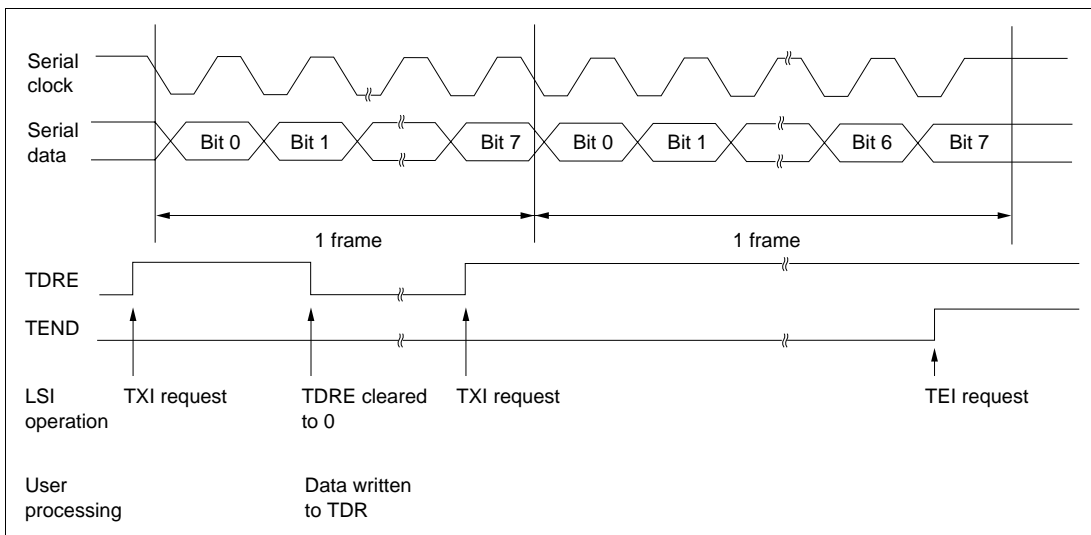

Figure 10.12 Example of Operation when Transmitting in Synchronous Mode

- Receiving

Figure 10.13 shows an example of a flowchart for data reception. This procedure should be followed for data reception after initializing SCI3.

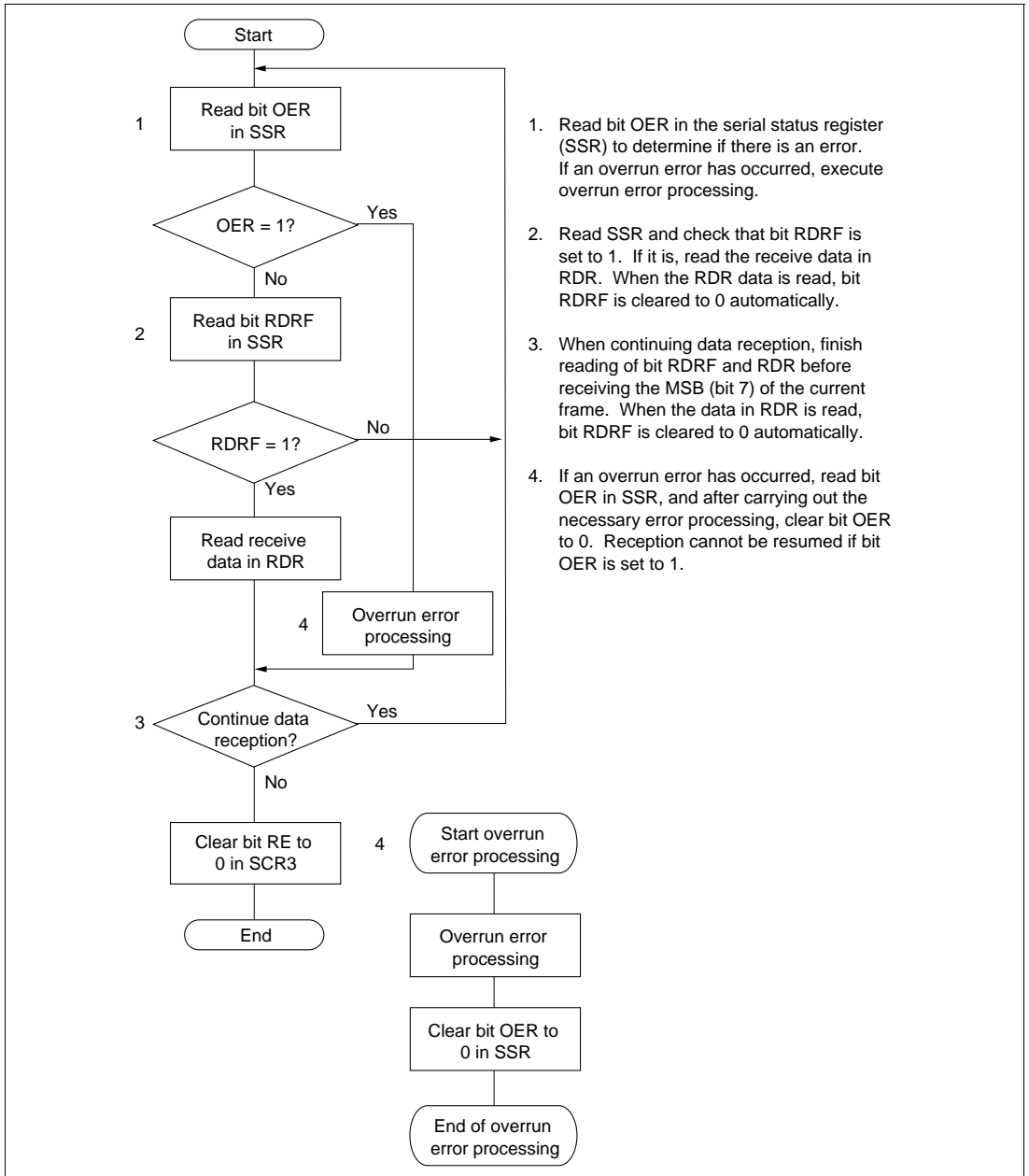

Figure 10.13 Example of Data Reception Flowchart (Synchronous Mode)

SCI3 operates as follows when receiving data.

SCI3 performs internal synchronization and begins reception in synchronization with the serial clock input or output.

The received data is placed in RSR in LSB-to-MSB order.

After the data has been received, SCI3 checks that bit RDRF is set to 0, indicating that the receive data can be transferred from RSR to RDR.

If this check shows that there is no overrun error, bit RDRF is set to 1, and the receive data is stored in RDR. If bit RIE is set to 1 in SCR3, an RXI interrupt is requested. If the check identifies an overrun error, bit OER is set to 1.

Bit RDRF remains set to 1. If bit RIE is set to 1 in SCR3, an ERI interrupt is requested.

See table 10.12 for the conditions for detecting a receive error, and receive data processing.

Note: No further receive operations are possible while a receive error flag is set. Bits OER, FER, PER, and RDRF must therefore be cleared to 0 before resuming reception.

Figure 10.14 shows an example of the operation when receiving in synchronous mode.

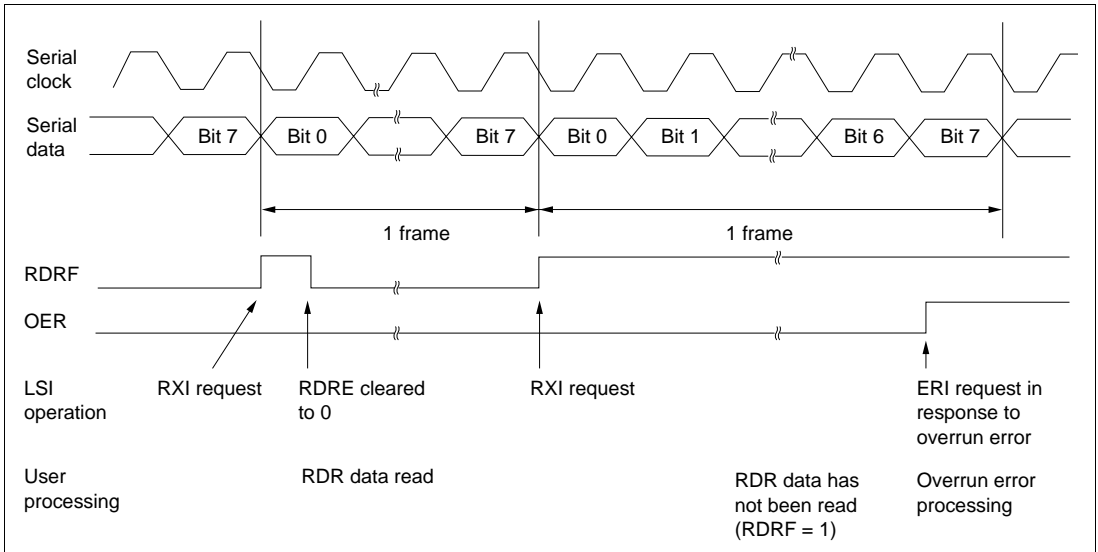
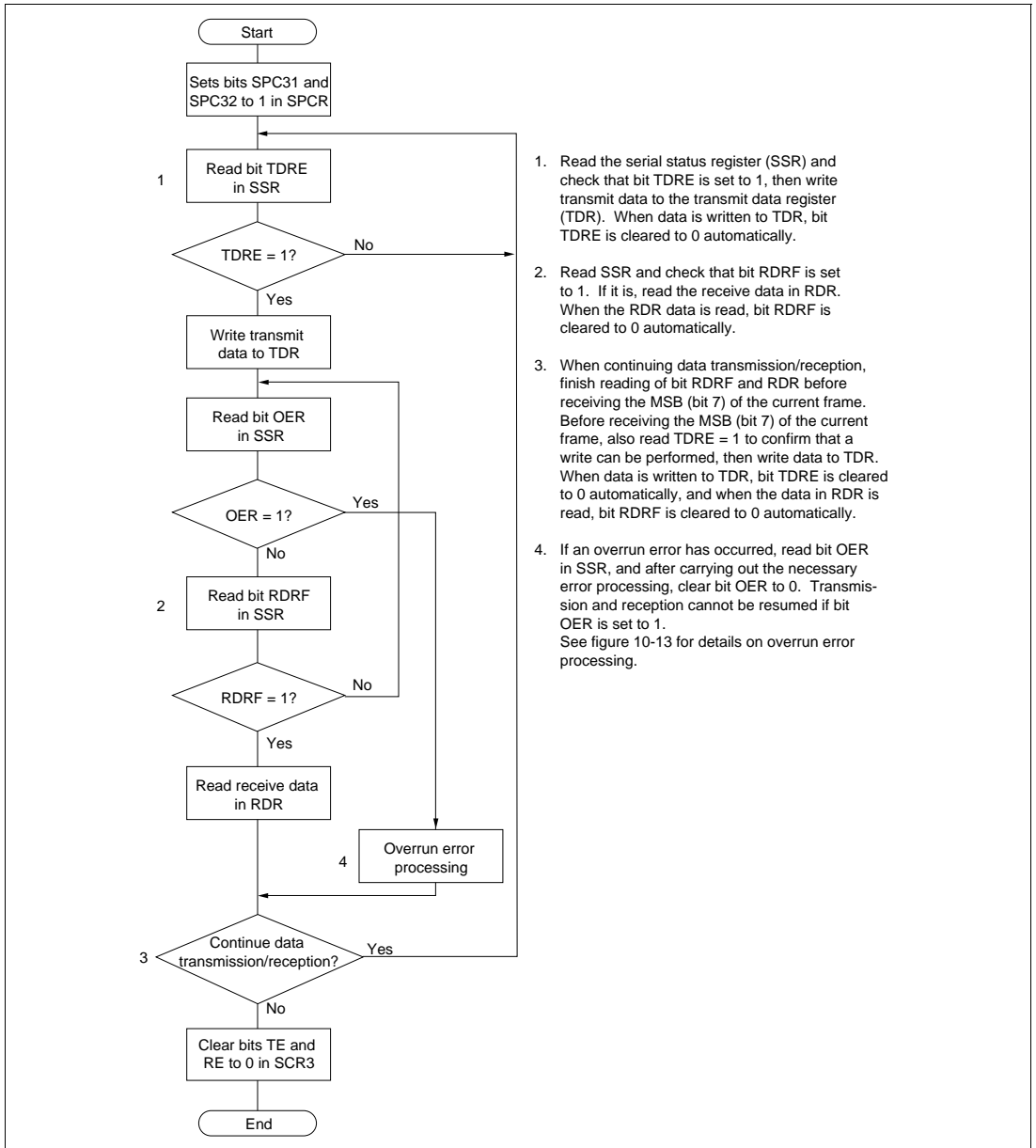

Figure 10.14 Example of Operation when Receiving in Synchronous Mode

- Simultaneous transmit/receive

Figure 10.15 shows an example of a flowchart for a simultaneous transmit/receive operation. This procedure should be followed for simultaneous transmission/reception after initializing SCI3.



1. Read the serial status register (SSR) and check that bit TDRE is set to 1, then write transmit data to the transmit data register (TDR). When data is written to TDR, bit TDRE is cleared to 0 automatically.
2. Read SSR and check that bit RDRF is set to 1. If it is, read the receive data in RDR. When the RDR data is read, bit RDRF is cleared to 0 automatically.
3. When continuing data transmission/reception, finish reading of bit RDRF and RDR before receiving the MSB (bit 7) of the current frame. Before receiving the MSB (bit 7) of the current frame, also read TDRE = 1 to confirm that a write can be performed, then write data to TDR. When data is written to TDR, bit TDRE is cleared to 0 automatically, and when the data in RDR is read, bit RDRF is cleared to 0 automatically.
4. If an overrun error has occurred, read bit OER in SSR, and after carrying out the necessary error processing, clear bit OER to 0. Transmission and reception cannot be resumed if bit OER is set to 1. See figure 10-13 for details on overrun error processing.

Figure 10.15 Example of Simultaneous Data Transmission/Reception Flowchart (Synchronous Mode)

- Notes:
1. When switching from transmission to simultaneous transmission/reception, check that SCI3 has finished transmitting and that bits TDRE and TEND are set to 1, clear bit TE to 0, and then set bits TE and RE to 1 simultaneously.
 2. When switching from reception to simultaneous transmission/reception, check that SCI3 has finished receiving, clear bit RE to 0, then check that bit RDRF and the error flags (OER, FER, and PER) are cleared to 0, and finally set bits TE and RE to 1 simultaneously.

10.3.4 Multiprocessor Communication Function

The multiprocessor communication function enables data to be exchanged among a number of processors on a shared communication line. Serial data communication is performed in asynchronous mode using the multiprocessor format (in which a multiprocessor bit is added to the transfer data).

In multiprocessor communication, each receiver is assigned its own ID code. The serial communication cycle consists of two cycles, an ID transmission cycle in which the receiver is specified, and a data transmission cycle in which the transfer data is sent to the specified receiver. These two cycles are differentiated by means of the multiprocessor bit, 1 indicating an ID transmission cycle, and 0, a data transmission cycle.

The sender first sends transfer data with a 1 multiprocessor bit added to the ID code of the receiver it wants to communicate with, and then sends transfer data with a 0 multiprocessor bit added to the transmit data. When a receiver receives transfer data with the multiprocessor bit set to 1, it compares the ID code with its own ID code, and if they are the same, receives the transfer data sent next. If the ID codes do not match, it skips the transfer data until data with the multiprocessor bit set to 1 is sent again.

In this way, a number of processors can exchange data among themselves.

Figure 10.16 shows an example of communication between processors using the multiprocessor format.

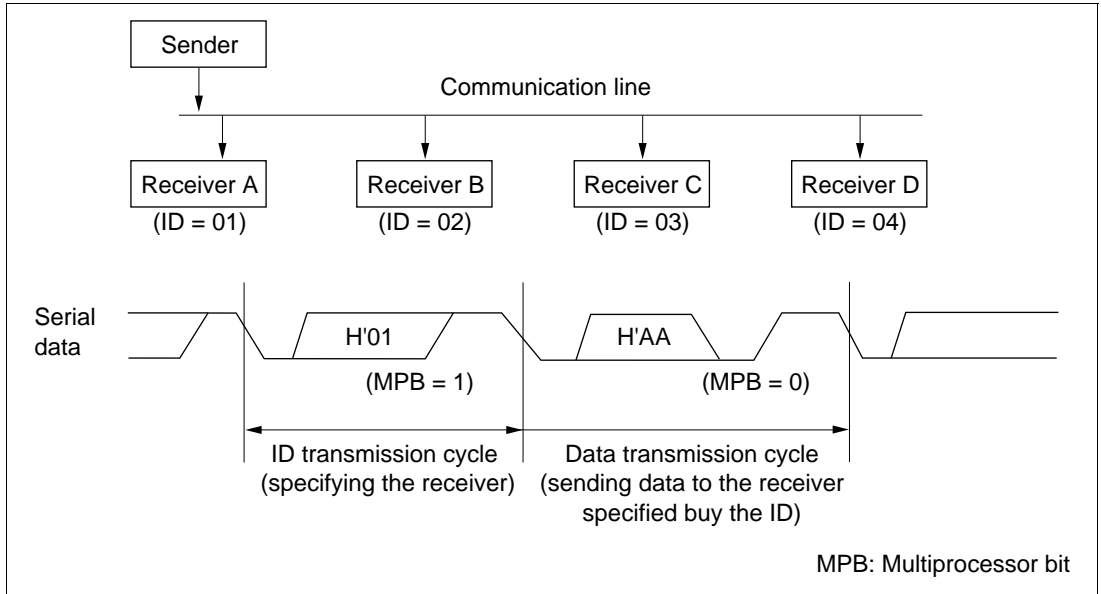

Figure 10.16 Example of Inter-Processor Communication Using Multiprocessor Format (Sending data H'AA to receiver A)

There is a choice of four data transfer formats. If a multiprocessor format is specified, the parity bit specification is invalid. See table 10.11 for details.

For details on the clock used in multiprocessor communication, see 10.1.4, Operation in Synchronous Mode.

- Multiprocessor transmitting

Figure 10.17 shows an example of a flowchart for multiprocessor data transmission. This procedure should be followed for multiprocessor data transmission after initializing SCI3.

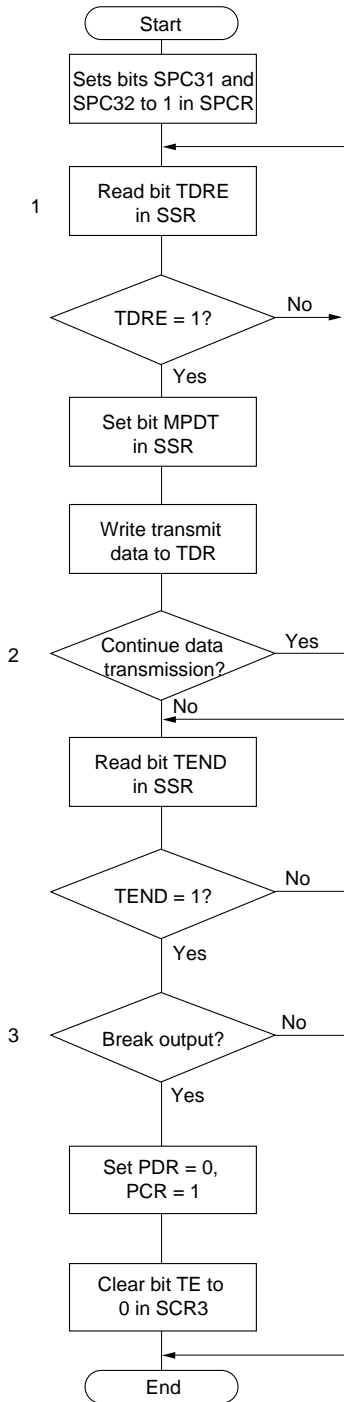

1. Read the serial status register (SSR) and check that bit TDRE is set to 1, then set bit MPBT in SSR to 0 or 1 and write transmit data to the transmit data register (TDR). When data is written to TDR, bit TDRE is cleared to 0 automatically.
2. When continuing data transmission, be sure to read TDRE = 1 to confirm that a write can be performed before writing data to TDR. When data is written to TDR, bit TDRE is cleared to 0 automatically.
3. If a break is to be output when data transmission ends, set the port PCR to 1 and clear the port PDR to 0, then clear bit TE in SCR3 to 0.

Figure 10.17 Example of Multiprocessor Data Transmission Flowchart

SCI3 operates as follows when transmitting data.

SCI3 monitors bit TDRE in SSR, and when it is cleared to 0, recognizes that data has been written to TDR and transfers data from TDR to TSR. It then sets bit TDRE to 1 and starts transmitting. If bit TIE in SCR3 is set to 1 at this time, a TXI request is made.

Serial data is transmitted from the TXD pin using the relevant data transfer format in table 10.11. When the stop bit is sent, SCI3 checks bit TDRE. If bit TDRE is cleared to 0, SCI3 transfers data from TDR to TSR, and when the stop bit has been sent, starts transmission of the next frame. If bit TDRE is set to 1 bit TEND in SSR bit is set to 1, the mark state, in which 1s are transmitted, is established after the stop bit has been sent. If bit TEIE in SCR3 is set to 1 at this time, a TEI request is made.

Figure 10.18 shows an example of the operation when transmitting using the multiprocessor format.

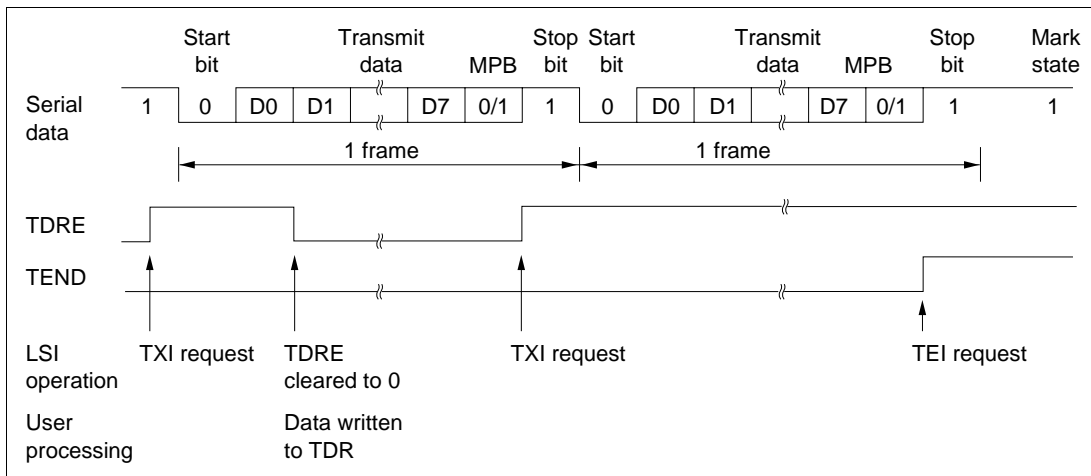
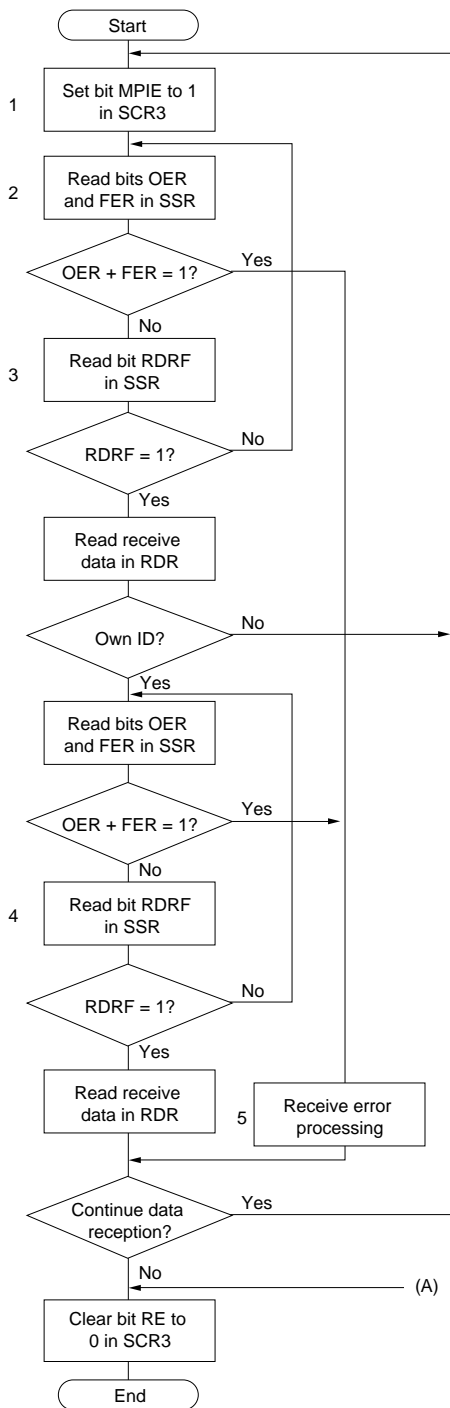

Figure 10.18 Example of Operation when Transmitting using Multiprocessor Format (8-bit data, multiprocessor bit, 1 stop bit)

- Multiprocessor receiving

Figure 10.19 shows an example of a flowchart for multiprocessor data reception. This procedure should be followed for multiprocessor data reception after initializing SCI3.



1. Set bit MPIO to 1 in SCR3.
2. Read bits OER and FER in the serial status register (SSR) to determine if there is an error. If a receive error has occurred, execute receive error processing.
3. Read SSR and check that bit RDRF is set to 1. If it is, read the receive data in RDR and compare it with this receiver's own ID. If the ID is not this receiver's, set bit MPIO to 1 again. When the RDR data is read, bit RDRF is cleared to 0 automatically.
4. Read SSR and check that bit RDRF is set to 1, then read the data in RDR.
5. If a receive error has occurred, read bits OER and FER in SSR to identify the error, and after carrying out the necessary error processing, ensure that bits OER and FER are both cleared to 0. Reception cannot be resumed if either of these bits is set to 1. In the case of a framing error, a break can be detected by reading the value of the RXD_{3x} pin.

Figure 10.19 Example of Multiprocessor Data Reception Flowchart

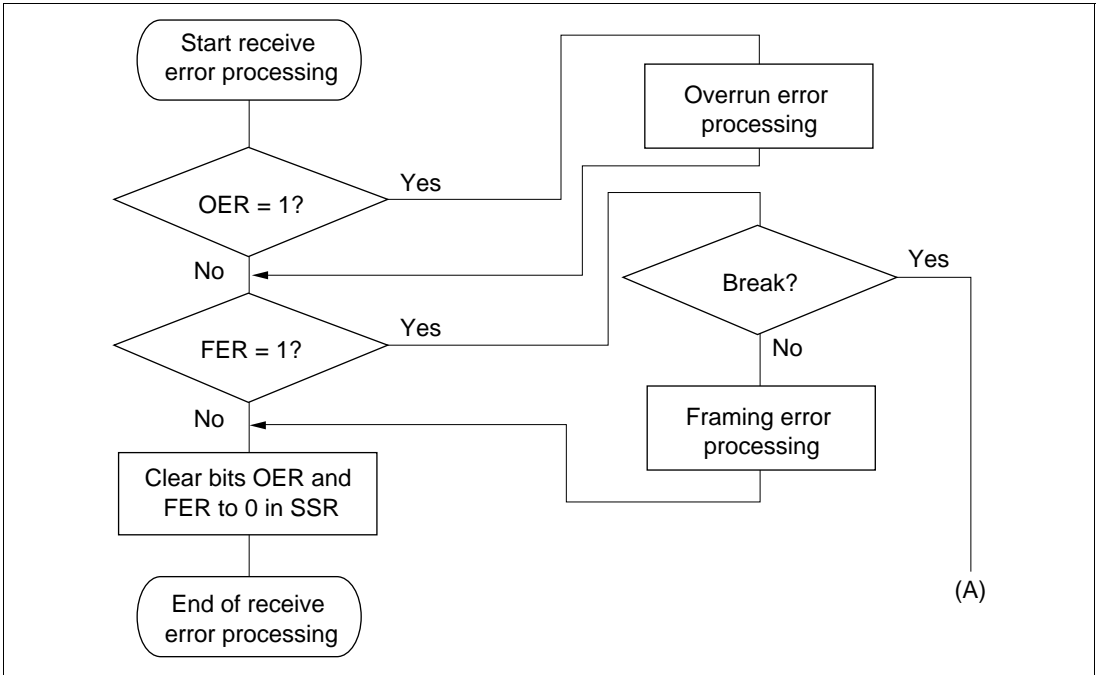
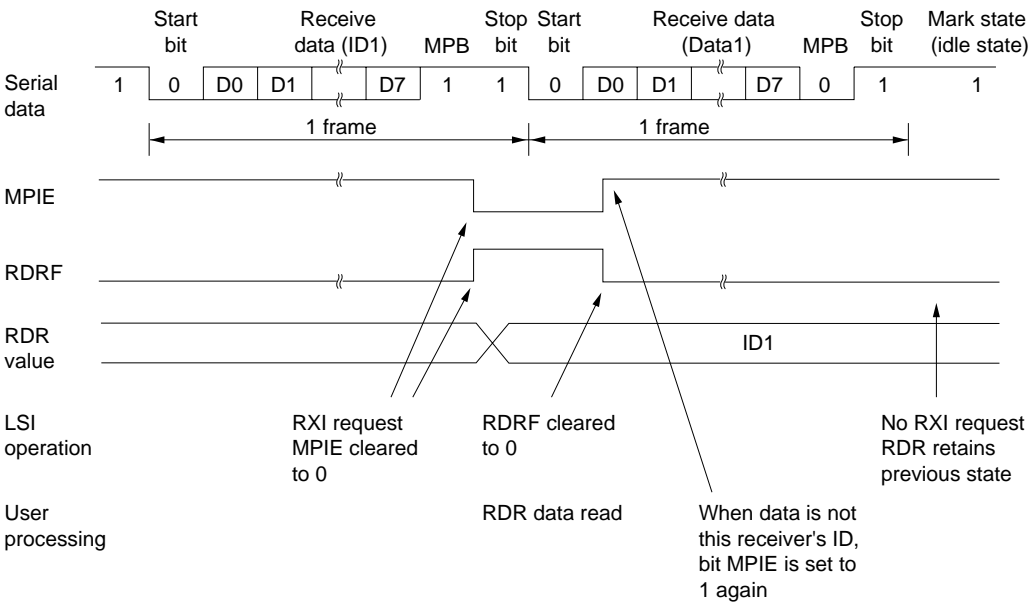
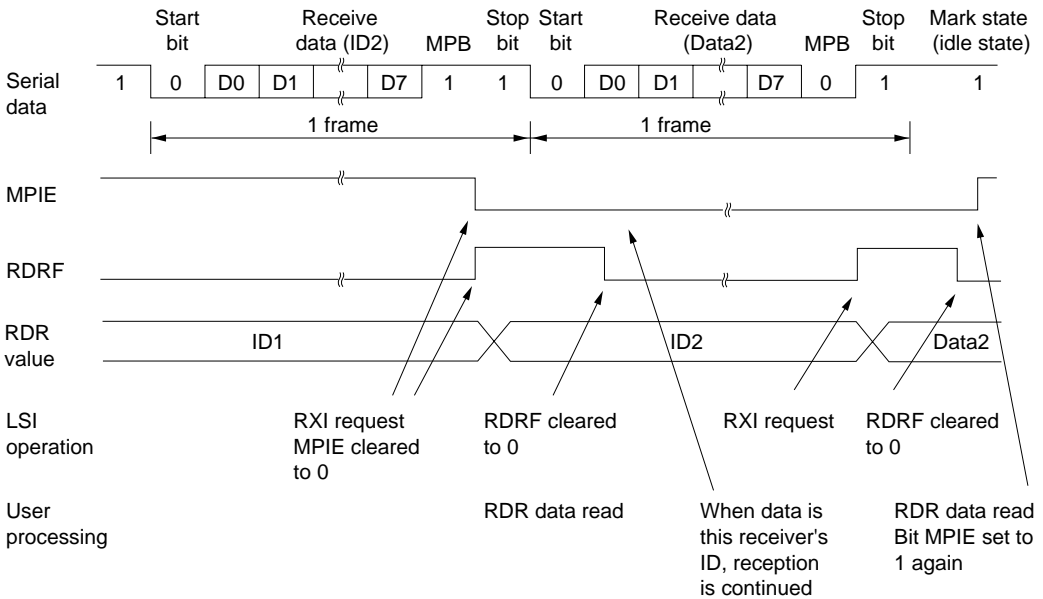

Figure 10.19 Example of Multiprocessor Data Reception Flowchart (cont)

Figure 10.20 shows an example of the operation when receiving using the multiprocessor format.



(a) When data does not match this receiver's ID



(b) When data matches this receiver's ID

Figure 10.20 Example of Operation when Receiving using Multiprocessor Format (8-bit data, multiprocessor bit, 1 stop bit)

10.4 Interrupts

SCI3 can generate six kinds of interrupts: transmit end, transmit data empty, receive data full, and three receive error interrupts (overrun error, framing error, and parity error). These interrupts have the same vector address.

The various interrupt requests are shown in table 10.13.

Table 10.13 SCI3 Interrupt Requests

| Interrupt Abbreviation | Interrupt Request | Vector Address |
|-------------------------------|---|-----------------------|
| RXI | Interrupt request initiated by receive data full flag (RDRF) | H'0022/H'0024 |
| TXI | Interrupt request initiated by transmit data empty flag (TDRE) | |
| TEI | Interrupt request initiated by transmit end flag (TEND) | |
| ERI | Interrupt request initiated by receive error flag (OER, FER, PER) | |

Each interrupt request can be enabled or disabled by means of bits TIE and RIE in SCR3.

When bit TDRE is set to 1 in SSR, a TXI interrupt is requested. When bit TEND is set to 1 in SSR, a TEI interrupt is requested. These two interrupts are generated during transmission.

The initial value of bit TDRE in SSR is 1. Therefore, if the transmit data empty interrupt request (TXI) is enabled by setting bit TIE to 1 in SCR3 before transmit data is transferred to TDR, a TXI interrupt will be requested even if the transmit data is not ready.

Also, the initial value of bit TEND in SSR is 1. Therefore, if the transmit end interrupt request (TEI) is enabled by setting bit TEIE to 1 in SCR3 before transmit data is transferred to TDR, a TEI interrupt will be requested even if the transmit data has not been sent.

Effective use of these interrupt requests can be made by having processing that transfers transmit data to TDR carried out in the interrupt service routine.

To prevent the generation of these interrupt requests (TXI and TEI), on the other hand, the enable bits for these interrupt requests (bits TIE and TEIE) should be set to 1 after transmit data has been transferred to TDR.

When bit RDRF is set to 1 in SSR, an RXI interrupt is requested, and if any of bits OER, PER, and FER is set to 1, an ERI interrupt is requested. These two interrupt requests are generated during reception.

For further details, see 3.3, Interrupts.

10.5 Application Notes

The following points should be noted when using SCI3.

1. Relation between writes to TDR and bit TDRE

Bit TDRE in the serial status register (SSR) is a status flag that indicates that data for serial transmission has not been prepared in TDR. When data is written to TDR, bit TDRE is cleared to 0 automatically. When SCI3 transfers data from TDR to TSR, bit TDRE is set to 1.

Data can be written to TDR irrespective of the state of bit TDRE, but if new data is written to TDR while bit TDRE is cleared to 0, the data previously stored in TDR will be lost if it has not yet been transferred to TSR. Accordingly, to ensure that serial transmission is performed dependably, you should first check that bit TDRE is set to 1, then write the transmit data to TDR once only (not two or more times).

2. Operation when a number of receive errors occur simultaneously

If a number of receive errors are detected simultaneously, the status flags in SSR will be set to the states shown in table 10.14. If an overrun error is detected, data transfer from RSR to RDR will not be performed, and the receive data will be lost.

Table 10.14 SSR Status Flag States and Receive Data Transfer

| SSR Status Flags | | | | Receive Data Transfer | |
|------------------|-----|-----|-----|-----------------------|--|
| RDRF* | OER | FER | PER | RSR → RDR | Receive Error Status |
| 1 | 1 | 0 | 0 | X | Overrun error |
| 0 | 0 | 1 | 0 | O | Framing error |
| 0 | 0 | 0 | 1 | O | Parity error |
| 1 | 1 | 1 | 0 | X | Overrun error + framing error |
| 1 | 1 | 0 | 1 | X | Overrun error + parity error |
| 0 | 0 | 1 | 1 | O | Framing error + parity error |
| 1 | 1 | 1 | 1 | X | Overrun error + framing error + parity error |

O : Receive data is transferred from RSR to RDR.

X : Receive data is not transferred from RSR to RDR.

Note: * Bit RDRF retains its state prior to data reception. However, note that if RDR is read after an overrun error has occurred in a frame because reading of the receive data in the previous frame was delayed, RDRF will be cleared to 0.

3. Break detection and processing

When a framing error is detected, a break can be detected by reading the value of the RXD_{3x} pin directly. In a break, the input from the RXD_{3x} pin becomes all 0s, with the result that bit FER is set and bit PER may also be set.

SCI3 continues the receive operation even after receiving a break. Note, therefore, that even though bit FER is cleared to 0 it will be set to 1 again.

4. Mark state and break detection

When bit TE is cleared to 0, the TXD_{3x} pin functions as an I/O port whose input/output direction and level are determined by PDR and PCR. This fact can be used to set the TXD_{3x} pin to the mark state, or to detect a break during transmission.

To keep the communication line in the mark state (1 state) until bit TE is set to 1, set PCR = 1 and PDR = 1. Since bit TE is cleared to 0 at this time, the TXD_{3x} pin functions as an I/O port and 1 is output.

To detect a break, clear bit TE to 0 after setting PCR = 1 and PDR = 0.

When bit TE is cleared to 0, the transmission unit is initialized regardless of the current transmission state, the TXD_{3x} pin functions as an I/O port, and 0 is output from the TXD_{3x} pin.

5. Receive error flags and transmit operation (synchronous mode only)

When a receive error flag (OER, PER, or FER) is set to 1, transmission cannot be started even if bit TDRE is cleared to 0. The receive error flags must be cleared to 0 before starting transmission.

Note also that receive error flags cannot be cleared to 0 even if bit RE is cleared to 0.

6. Receive data sampling timing and receive margin in asynchronous mode

In asynchronous mode, SCI3 operates on a basic clock with a frequency 16 times the transfer rate. When receiving, SCI3 performs internal synchronization by sampling the falling edge of the start bit with the basic clock. Receive data is latched internally at the 8th rising edge of the basic clock. This is illustrated in figure 10.21.

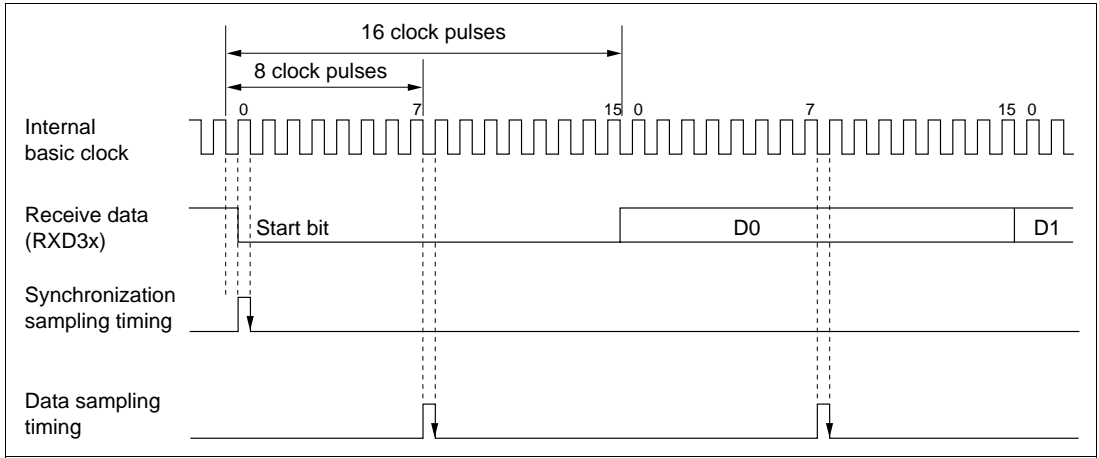

Figure 10.21 Receive Data Sampling Timing in Asynchronous Mode

Consequently, the receive margin in asynchronous mode can be expressed as shown in equation (1).

$$M = \left\{ \left(0.5 - \frac{1}{2N} \right) - \frac{D - 0.5}{N} - (L - 0.5) F \right\} \times 100 [\%] \quad \dots \text{Equation (1)}$$

where

- M: Receive margin (%)
- N: Ratio of bit rate to clock (N = 16)
- D: Clock duty (D = 0.5 to 1.0)
- L: Frame length (L = 9 to 12)
- F: Absolute value of clock frequency deviation

Substituting 0 for F (absolute value of clock frequency deviation) and 0.5 for D (clock duty) in equation (1), a receive margin of 46.875% is given by equation (2).

When D = 0.5 and F = 0,

$$M = \left\{ 0.5 - \frac{1}{2 \times 16} \right\} \times 100 [\%]$$

$$= 46.875\% \quad \dots \text{Equation (2)}$$

However, this is only a computed value, and a margin of 20% to 30% should be allowed when carrying out system design.

7. Relation between RDR reads and bit RDRF

In a receive operation, SCI3 continually checks the RDRF flag. If bit RDRF is cleared to 0 when reception of one frame ends, normal data reception is completed. If bit RDRF is set to 1, this indicates that an overrun error has occurred.

When the contents of RDR are read, bit RDRF is cleared to 0 automatically. Therefore, if bit RDR is read more than once, the second and subsequent read operations will be performed while bit RDRF is cleared to 0. Note that, when an RDR read is performed while bit RDRF is cleared to 0, if the read operation coincides with completion of reception of a frame, the next frame of data may be read. This is illustrated in figure 10.22.

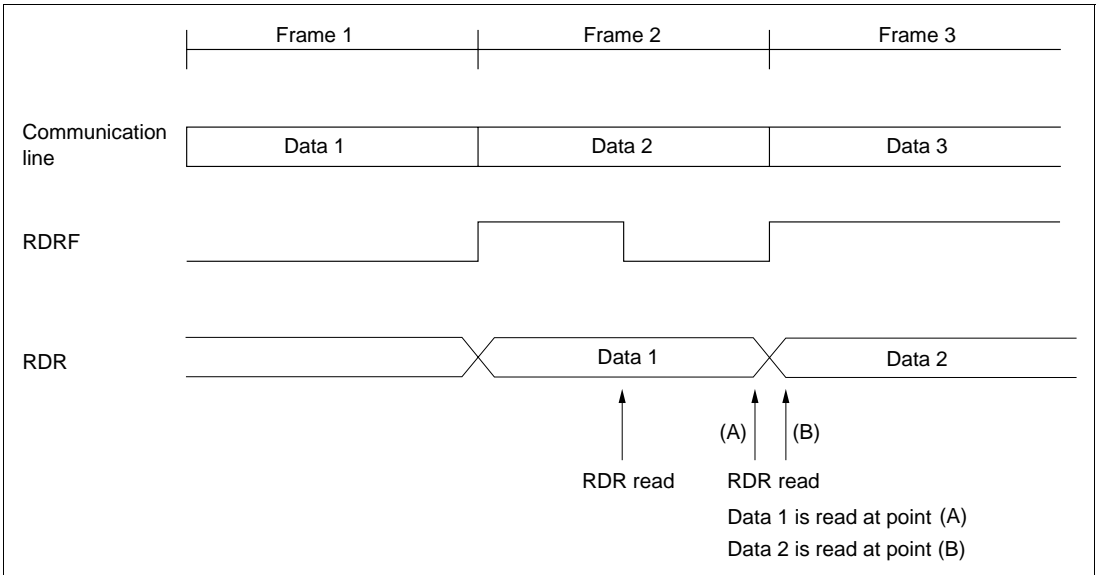

Figure 10.22 Relation between RDR Read Timing and Data

In this case, only a single RDR read operation (not two or more) should be performed after first checking that bit RDRF is set to 1. If two or more reads are performed, the data read the first time should be transferred to RAM, etc., and the RAM contents used. Also, ensure that there is sufficient margin in an RDR read operation before reception of the next frame is completed. To be precise in terms of timing, the RDR read should be completed before bit 7 is transferred in synchronous mode, or before the STOP bit is transferred in asynchronous mode.

8. Transmit and receive operations when making a state transition

Make sure that transmit and receive operations have completely finished before carrying out state transition processing.

9. Switching SCK₃ function

If pin SCK₃ is used as a clock output pin by SCI3 in synchronous mode and is then switched to a general input/output pin (a pin with a different function), the pin outputs a low level signal for half a system clock (\emptyset) cycle immediately after it is switched.

This can be prevented by either of the following methods according to the situation.

a. When an SCK₃ function is switched from clock output to non clock-output

When stopping data transfer, issue one instruction to clear bits TE and RE to 0 and to set bits CKE1 and CKE0 in SCR3 to 1 and 0, respectively. In this case, bit COM in SMR should be left 1. The above prevents SCK₃ from being used as a general input/output pin. To avoid an intermediate level of voltage from being applied to SCK₃, the line connected to SCK₃ should be pulled up to the V_{CC} level via a resistor, or supplied with output from an external device.

b. When an SCK₃ function is switched from clock output to general input/output

When stopping data transfer,

- (i) Issue one instruction to clear bits TE and RE to 0 and to set bits CKE1 and CKE0 in SCR3 to 1 and 0, respectively.
- (ii) Clear bit COM in SMR to 0
- (iii) Clear bits CKE1 and CKE0 in SCR3 to 0

Note that special care is also needed here to avoid an intermediate level of voltage from being applied to SCK₃.

10. Set up at subactive or subsleep mode

At subactive or subsleep mode, SCI3 becomes possible use only at CPU clock is $\emptyset w/2$.

11.1 Overview

The H8/3864 Series is provided with a 14-bit PWM (pulse width modulator) on-chip, which can be used as a D/A converter by connecting a low-pass filter.

11.1.1 Features

Features of the 14-bit PWM are as follows.

- Choice of two conversion periods

Any of the following four conversion periods can be chosen:

131,072/ ϕ , with a minimum modulation width of 8/ ϕ (PWCR1 = 1, PWCR0 = 1)

65,536/ ϕ , with a minimum modulation width of 4/ ϕ (PWCR1 = 1, PWCR0 = 0)

32,768/ ϕ , with a minimum modulation width of 2/ ϕ (PWCR1 = 0, PWCR0 = 1)

16,384/ ϕ , with a minimum modulation width of 1/ ϕ (PWCR1 = 0, PWCR0 = 0)

- Pulse division method for less ripple
- Use of module standby mode enables this module to be placed in standby mode independently when not used.

11.1.2 Block Diagram

Figure 11.1 shows a block diagram of the 14-bit PWM.

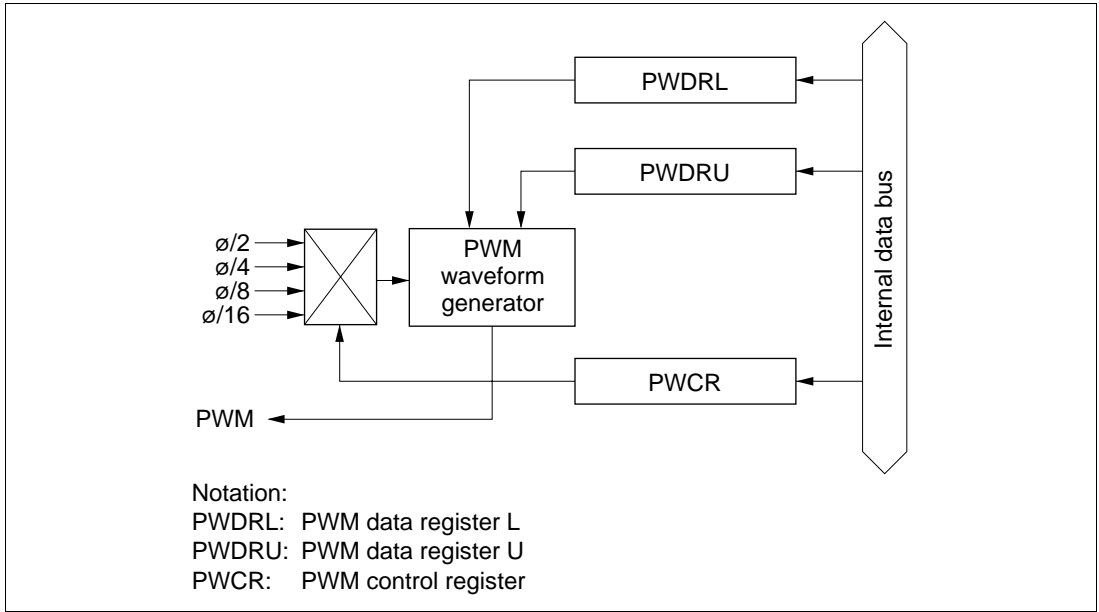

Figure 11.1 Block Diagram of the 14-bit PWM

11.1.3 Pin Configuration

Table 11.1 shows the output pin assigned to the 14-bit PWM.

Table 11.1 Pin Configuration

| Name | Abbrev. | I/O | Function |
|----------------|---------|--------|------------------------------------|
| PWM output pin | PWM | Output | Pulse-division PWM waveform output |

11.1.4 Register Configuration

Table 11.2 shows the register configuration of the 14-bit PWM.

Table 11.2 Register Configuration

| Name | Abbrev. | R/W | Initial Value | Address |
|-----------------------|---------|-----|---------------|---------|
| PWM control register | PWCR | W | H'FC | H'FFD0 |
| PWM data register U | PWDRU | W | H'C0 | H'FFD1 |
| PWM data register L | PWDR L | W | H'00 | H'FFD2 |
| Clock stop register 2 | CKSTPR2 | R/W | H'FF | H'FFFB |

11.2 Register Descriptions

11.2.1 PWM Control Register (PWCR)

| | | | | | | | | |
|---------------|---|---|---|---|---|---|-------|-------|
| Bit | 7 | 6 | 5 | 4 | 3 | 2 | 1 | 0 |
| | — | — | — | — | — | — | PWCR1 | PWCR0 |
| Initial value | 1 | 1 | 1 | 1 | 1 | 1 | 0 | 0 |
| Read/Write | — | — | — | — | — | — | W | W |

PWCR is an 8-bit write-only register for input clock selection.

Upon reset, PWCR is initialized to H'FC.

Bits 7 to 2: Reserved bits

Bits 7 to 2 are reserved; they are always read as 1, and cannot be modified.

Bits 1 and 0: Clock select 1 and 0 (PWCR1, PWCR0)

Bits 1 and 0 select the clock supplied to the 14-bit PWM. These bits are write-only bits; they are always read as 1.

| Bit 1 PWCR1 | Bit 0 PWCR0 | Description |
|----------------|----------------|--|
| 0 | 0 | The input clock is $\phi/2$ ($t\phi^* = 2/\phi$) The conversion period is $16,384/\phi$, with a minimum modulation width of $1/\phi$ (initial value) |
| 0 | 1 | The input clock is $\phi/4$ ($t\phi^* = 4/\phi$) The conversion period is $32,768/\phi$, with a minimum modulation width of $2/\phi$ |
| 1 | 0 | The input clock is $\phi/8$ ($t\phi^* = 8/\phi$) The conversion period is $65,536/\phi$, with a minimum modulation width of $4/\phi$ |
| 1 | 1 | The input clock is $\phi/16$ ($t\phi^* = 16/\phi$) The conversion period is $131,072/\phi$, with a minimum modulation width of $8/\phi$ |

Note: * Period of PWM input clock.

11.2.2 PWM Data Registers U and L (PWDRU, PWDRL)

PWDRU

| Bit | 7 | 6 | 5 | 4 | 3 | 2 | 1 | 0 |
|---------------|---|---|--------|--------|--------|--------|--------|--------|
| | — | — | PWDRU5 | PWDRU4 | PWDRU3 | PWDRU2 | PWDRU1 | PWDRU0 |
| Initial value | 1 | 1 | 0 | 0 | 0 | 0 | 0 | 0 |
| Read/Write | — | — | W | W | W | W | W | W |

PWDRL

| Bit | 7 | 6 | 5 | 4 | 3 | 2 | 1 | 0 |
|---------------|--------|--------|--------|--------|--------|--------|--------|--------|
| | PWDRL7 | PWDRL6 | PWDRL5 | PWDRL4 | PWDRL3 | PWDRL2 | PWDRL1 | PWDRL0 |
| Initial value | 0 | 0 | 0 | 0 | 0 | 0 | 0 | 0 |
| Read/Write | W | W | W | W | W | W | W | W |

PWDRU and PWDRL form a 14-bit write-only register, with the upper 6 bits assigned to PWDRU and the lower 8 bits to PWDRL. The value written to PWDRU and PWDRL gives the total high-level width of one PWM waveform cycle.

When 14-bit data is written to PWDRU and PWDRL, the register contents are latched in the PWM waveform generator, updating the PWM waveform generation data. The 14-bit data should always be written in the following sequence:

1. Write the lower 8 bits to PWDRL.
2. Write the upper 6 bits to PWDRU.

PWDRU and PWDRL are write-only registers. If they are read, all bits are read as 1.

Upon reset, PWDRU and PWDRL are initialized to H'C000.

11.2.3 Clock Stop Register 2 (CKSTPR2)

| Bit | 7 | 6 | 5 | 4 | 3 | 2 | 1 | 0 |
|---------------|---|---|---|---|---------|---------|---------|---------|
| | — | — | — | — | AECKSTP | WDCKSTP | PWCKSTP | LDCKSTP |
| Initial value | 1 | 1 | 1 | 1 | 1 | 1 | 1 | 1 |
| Read/Write | — | — | — | — | R/W | R/W | R/W | R/W |

CKSTPR2 is an 8-bit read/write register that performs module standby mode control for peripheral modules. Only the bit relating to the PWM is described here. For details of the other bits, see the sections on the relevant modules.

Bit 1: PWM module standby mode control (PWCKSTP)

Bit 1 controls setting and clearing of module standby mode for the PWM.

| PWCKSTP | Description |
|----------------|--|
| 0 | PWM is set to module standby mode |
| 1 | PWM module standby mode is cleared (initial value) |

11.3 Operation

11.3.1 Operation

When using the 14-bit PWM, set the registers in the following sequence.

1. Set bit PWM in port mode register 3 (PMR3) to 1 so that pin P3₀/PWM is designated for PWM output.
2. Set bits PWCR1 and PWCR0 in the PWM control register (PWCR) to select a conversion period of 131,072/ ϕ (PWCR1 = 1, PWCR0 = 1), 65,536/ ϕ (PWCR1 = 1, PWCR0 = 0), 32,768/ ϕ (PWCR1 = 0, PWCR0 = 1), or 16,384/ ϕ (PWCR1 = 0, PWCR0 = 0).
3. Set the output waveform data in PWM data registers U and L (PWDRU/L). Be sure to write in the correct sequence, first PWDRL then PWDRU. When data is written to PWDRU, the data in these registers will be latched in the PWM waveform generator, updating the PWM waveform generation in synchronization with internal signals.

One conversion period consists of 64 pulses, as shown in figure 11.2. The total of the high-level pulse widths during this period (T_H) corresponds to the data in PWDRU and PWDRL. This relation can be represented as follows.

$$T_H = (\text{data value in PWDRU and PWDRL} + 64) \times t_{\phi}/2$$

where t_{ϕ} is the PWM input clock period: 2/ ϕ (PWCR = H'0), 4/ ϕ (PWCR = H'1), 8/ ϕ (PWCR = H'2), or 16/ ϕ (PWCR = H'3).

Example: Settings in order to obtain a conversion period of 32,768 μ s:

When PWCR1 = 0 and PWCR0 = 0, the conversion period is 16,384/ ϕ , so ϕ must be 0.5 MHz. In this case, $t_{fn} = 512 \mu$ s, with 1/ ϕ (resolution) = 2.0 μ s.

When PWCR1 = 0 and PWCR0 = 1, the conversion period is 32,768/ ϕ , so ϕ must be 1 MHz. In this case, $t_{fn} = 512 \mu$ s, with 2/ ϕ (resolution) = 2.0 μ s.

When PWCR1 = 1 and PWCR0 = 0, the conversion period is 65,536/ ϕ , so ϕ must be 2 MHz. In this case, $t_{fn} = 512 \mu$ s, with 4/ ϕ (resolution) = 2.0 μ s.

Accordingly, for a conversion period of 32,768 μ s, the system clock frequency (ϕ) must be 0.5 MHz, 1 MHz, or 2 MHz.

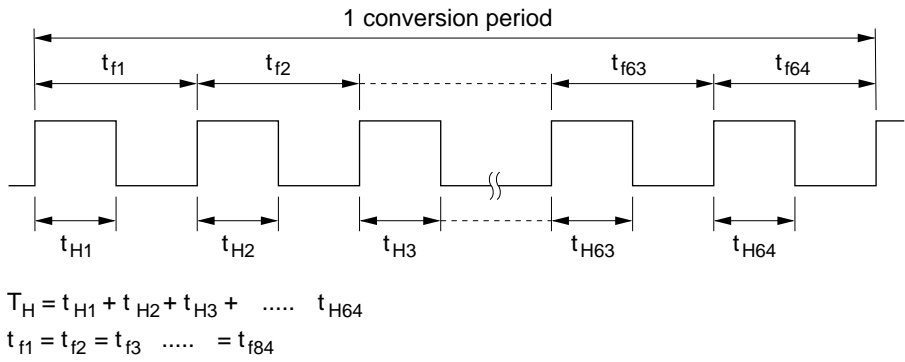

Figure 11.2 PWM Output Waveform

11.3.2 PWM Operation Modes

PWM operation modes are shown in table 11.3.

Table 11.3 PWM Operation Modes

| Operation Mode | Reset | Active | Sleep | Watch | Subactive | Subsleep | Standby | Module Standby |
|-----------------------|--------------|---------------|--------------|--------------|------------------|-----------------|----------------|-----------------------|
| PWCR | Reset | Functions | Functions | Held | Held | Held | Held | Held |
| PWDRU | Reset | Functions | Functions | Held | Held | Held | Held | Held |
| PWDRL | Reset | Functions | Functions | Held | Held | Held | Held | Held |

Section 12 A/D Converter

12.1 Overview

The H8/3864 Series includes on-chip a resistance-ladder-based successive-approximation analog-to-digital converter, and can convert up to 8 channels of analog input.

12.1.1 Features

The A/D converter has the following features.

- 10-bit resolution
- Eight input channels
- Conversion time: approx. 15.5 μ s per channel (at 2 MHz operation)
- Built-in sample-and-hold function
- Interrupt requested on completion of A/D conversion
- A/D conversion can be started by external trigger input
- Use of module standby mode enables this module to be placed in standby mode independently when not used.

12.1.2 Block Diagram

Figure 12.1 shows a block diagram of the A/D converter.

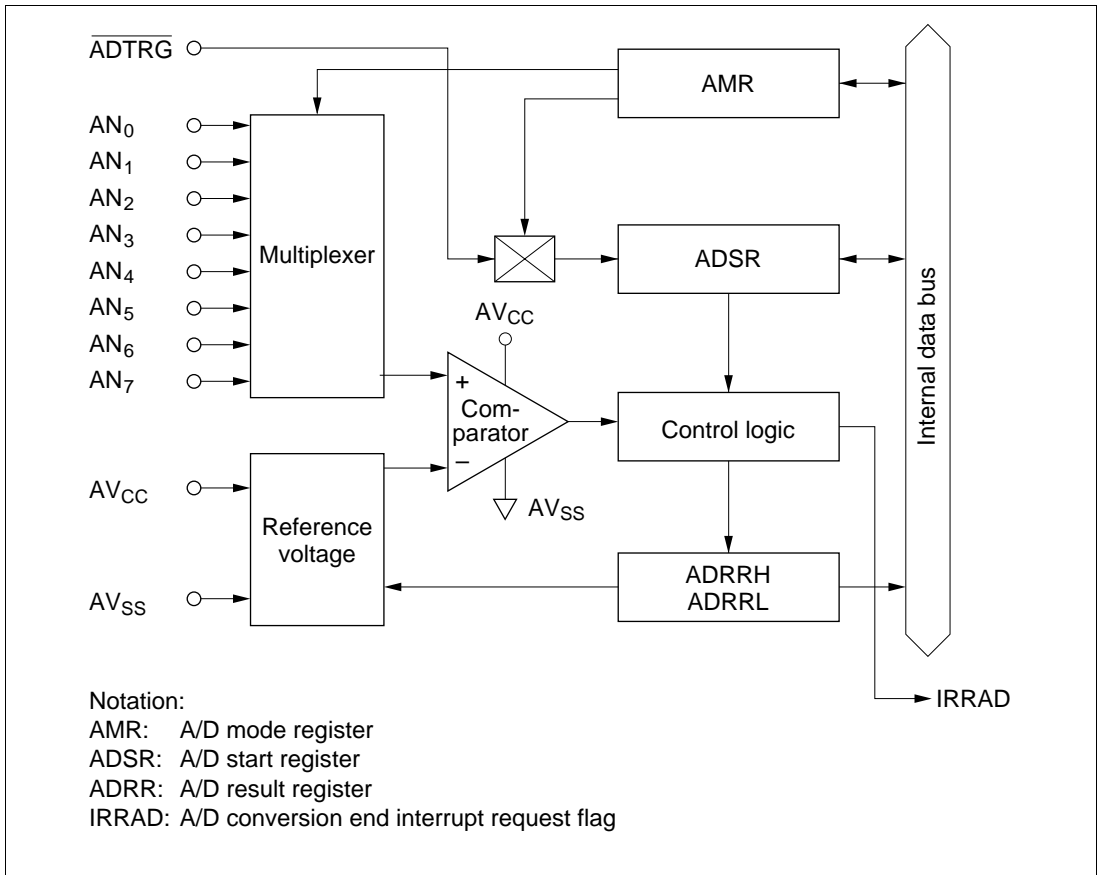

Figure 12.1 Block Diagram of the A/D Converter

12.1.3 Pin Configuration

Table 12.1 shows the A/D converter pin configuration.

Table 12.1 Pin Configuration

| Name | Abbrev. | I/O | Function |
|------------------------|---------|-------|--|
| Analog power supply | AVCC | Input | Power supply and reference voltage of analog part |
| Analog ground | AVSS | Input | Ground and reference voltage of analog part |
| Analog input 0 | AN0 | Input | Analog input channel 0 |
| Analog input 1 | AN1 | Input | Analog input channel 1 |
| Analog input 2 | AN2 | Input | Analog input channel 2 |
| Analog input 3 | AN3 | Input | Analog input channel 3 |
| Analog input 4 | AN4 | Input | Analog input channel 4 |
| Analog input 5 | AN5 | Input | Analog input channel 5 |
| Analog input 6 | AN6 | Input | Analog input channel 6 |
| Analog input 7 | AN7 | Input | Analog input channel 7 |
| External trigger input | ADTRG | Input | External trigger input for starting A/D conversion |

12.1.4 Register Configuration

Table 12.2 shows the A/D converter register configuration.

Table 12.2 Register Configuration

| Name | Abbrev. | R/W | Initial Value | Address |
|-----------------------|----------|-----|---------------|---------|
| A/D mode register | AMR | R/W | H'30 | H'FFC6 |
| A/D start register | ADSR | R/W | H'7F | H'FFC7 |
| A/D result register H | ADRRH | R | Not fixed | H'FFC4 |
| A/D result register L | ADRRLL | R | Not fixed | H'FFC5 |
| Clock stop register 1 | CKSTPRT1 | R/W | H'FF | H'FFFA |

12.2 Register Descriptions

12.2.1 A/D Result Registers (ADRRH, ADRRL)

| | | | | | | | | | | | | | | | | |
|---------------|-----------|-----------|-----------|-----------|-----------|-----------|-----------|-----------|-----------|-----------|---|---|---|---|---|---|
| Bit | 7 | 6 | 5 | 4 | 3 | 2 | 1 | 0 | 7 | 6 | 5 | 4 | 3 | 2 | 1 | 0 |
| | ADR9 | ADR8 | ADR7 | ADR6 | ADR5 | ADR4 | ADR3 | ADR2 | ADR1 | ADR0 | — | — | — | — | — | — |
| Initial value | Not fixed | Not fixed | Not fixed | Not fixed | Not fixed | Not fixed | Not fixed | Not fixed | Not fixed | Not fixed | — | — | — | — | — | — |
| Read/Write | R | R | R | R | R | R | R | R | R | R | — | — | — | — | — | — |
| | ADRRH | | | | | | | | ADRRL | | | | | | | |

ADRRH and ADRRL together comprise a 16-bit read-only register for holding the results of analog-to-digital conversion. The upper 8 bits of the data are held in ADRRH, and the lower 8 bits in ADRRL.

ADRRH and ADRRL can be read by the CPU at any time, but the ADRRH and ADRRL values during A/D conversion are not fixed. After A/D conversion is complete, the conversion result is stored as 10-bit data, and this data is held until the next conversion operation starts.

ADRRH and ADRRL are not cleared on reset.

12.2.2 A/D Mode Register (AMR)

| | | | | | | | | |
|---------------|-----|------|---|---|-----|-----|-----|-----|
| Bit | 7 | 6 | 5 | 4 | 3 | 2 | 1 | 0 |
| | CKS | TRGE | — | — | CH3 | CH2 | CH1 | CH0 |
| Initial value | 0 | 0 | 1 | 1 | 0 | 0 | 0 | 0 |
| Read/Write | R/W | R/W | — | — | R/W | R/W | R/W | R/W |

AMR is an 8-bit read/write register for specifying the A/D conversion speed, external trigger option, and the analog input pins.

Upon reset, AMR is initialized to H'30.

Bit 7: Clock select (CKS)

Bit 7 sets the A/D conversion speed.

| Bit 7 | | Conversion Time | |
|--------------|----------------------|------------------------|--------------------------|
| | | CKS | Conversion Period |
| 0 | 62/ϕ (initial value) | 62 μs | 31 μs |
| 1 | 31/ϕ | 31 μs | 15.5 μs* |

Note: * Operation is not guaranteed if the conversion time is less than 15.5 μs. Set bit 7 for a value of at least 15.5 μs.

Bit 6: External trigger select (TRGE)

Bit 6 enables or disables the start of A/D conversion by external trigger input.

| Bit 6 | |
|--------------|---|
| TRGE | Description |
| 0 | Disables start of A/D conversion by external trigger (initial value) |
| 1 | Enables start of A/D conversion by rising or falling edge of external trigger at pin ADTRG* |

Note: * The external trigger ($\overline{\text{ADTRG}}$) edge is selected by bit INTEG4 of IEGR. See 1. Interrupt edge select register (IEGR) in 3.3.2 for details.

Bits 5 and 4: Reserved bits

Bits 5 and 4 are reserved; they are always read as 1, and cannot be modified.

Bits 3 to 0: Channel select (CH3 to CH0)

Bits 3 to 0 select the analog input channel.

The channel selection should be made while bit ADSF is cleared to 0.

| Bit 3 CH3 | Bit 2 CH2 | Bit 1 CH1 | Bit 0 CH0 | Analog Input Channel | |
|--------------|--------------|--------------|--------------|----------------------|-----------------|
| 0 | 0 | * | * | No channel selected | (initial value) |
| 0 | 1 | 0 | 0 | AN0 | |
| 0 | 1 | 0 | 1 | AN1 | |
| 0 | 1 | 1 | 0 | AN2 | |
| 0 | 1 | 1 | 1 | AN3 | |
| 1 | 0 | 0 | 0 | AN4 | |
| 1 | 0 | 0 | 1 | AN5 | |
| 1 | 0 | 1 | 0 | AN6 | |
| 1 | 0 | 1 | 1 | AN7 | |

Note: * Don't care

12.2.3 A/D Start Register (ADSR)

| Bit | 7 | 6 | 5 | 4 | 3 | 2 | 1 | 0 |
|---------------|------|---|---|---|---|---|---|---|
| | ADSF | — | — | — | — | — | — | — |
| Initial value | 0 | 1 | 1 | 1 | 1 | 1 | 1 | 1 |
| Read/Write | R/W | — | — | — | — | — | — | — |

The A/D start register (ADSR) is an 8-bit read/write register for starting and stopping A/D conversion.

A/D conversion is started by writing 1 to the A/D start flag (ADSF) or by input of the designated edge of the external trigger signal, which also sets ADSF to 1. When conversion is complete, the converted data is set in ADDRHH and ADDRLL, and at the same time ADSF is cleared to 0.

Bit 7: A/D start flag (ADSF)

Bit 7 controls and indicates the start and end of A/D conversion.

Bit 7

| ADSF | Description |
|------|---|
| 0 | Read: Indicates the completion of A/D conversion (initial value) Write: Stops A/D conversion |
| 1 | Read: Indicates A/D conversion in progress Write: Starts A/D conversion |

Bits 6 to 0: Reserved bits

Bits 6 to 0 are reserved; they are always read as 1, and cannot be modified.

12.2.4 Clock Stop Register 1 (CKSTPR1)

| Bit | 7 | 6 | 5 | 4 | 3 | 2 | 1 | 0 |
|---------------|-----|----------|----------|---------|---------|---------|---------|---------|
| | — | S31CKSTP | S32CKSTP | ADCKSTP | TGCKSTP | TFCKSTP | TCCKSTP | TACKSTP |
| Initial value | 1 | 1 | 1 | 1 | 1 | 1 | 1 | 1 |
| Read/Write | R/W | R/W | R/W | R/W | R/W | R/W | R/W | R/W |

CKSTPR1 is an 8-bit read/write register that performs module standby mode control for peripheral modules. Only the bit relating to the A/D converter is described here. For details of the other bits, see the sections on the relevant modules.

Bit 4: A/D converter module standby mode control (ADCKSTP)

Bit 4 controls setting and clearing of module standby mode for the A/D converter.

ADCKSTP Description

| | |
|---|--|
| 0 | A/D converter is set to module standby mode |
| 1 | A/D converter module standby mode is cleared (initial value) |

12.3 Operation

12.3.1 A/D Conversion Operation

The A/D converter operates by successive approximations, and yields its conversion result as 10-bit data.

A/D conversion begins when software sets the A/D start flag (bit ADSF) to 1. Bit ADSF keeps a value of 1 during A/D conversion, and is cleared to 0 automatically when conversion is complete.

The completion of conversion also sets bit IRRAD in interrupt request register 2 (IRR2) to 1. An A/D conversion end interrupt is requested if bit IENAD in interrupt enable register 2 (IENR2) is set to 1.

If the conversion time or input channel needs to be changed in the A/D mode register (AMR) during A/D conversion, bit ADSF should first be cleared to 0, stopping the conversion operation, in order to avoid malfunction.

12.3.2 Start of A/D Conversion by External Trigger Input

The A/D converter can be made to start A/D conversion by input of an external trigger signal. External trigger input is enabled at pin $\overline{\text{ADTRG}}$ when bit IRQ4 in PMR1 is set to 1 and bit TRGE in AMR is set to 1. Then when the input signal edge designated in bit IEG4 of interrupt edge select register (IEGR) is detected at pin $\overline{\text{ADTRG}}$, bit ADSF in ADSR will be set to 1, starting A/D conversion.

Figure 12.2 shows the timing.

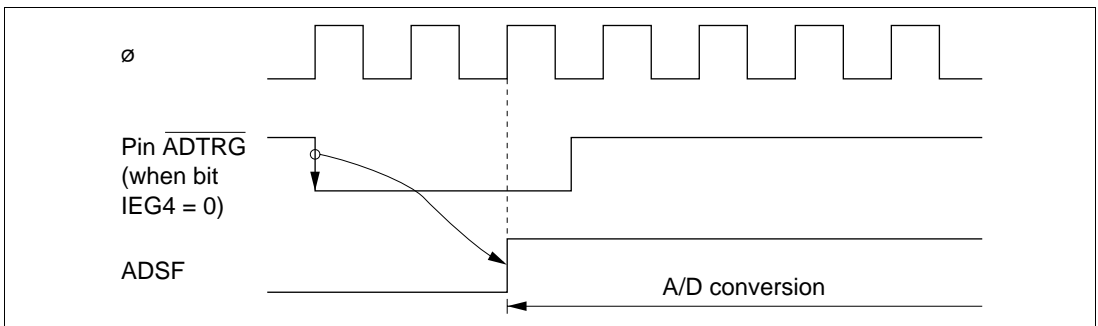

Figure 12.2 External Trigger Input Timing

12.3.3 A/D Converter Operation Modes

A/D converter operation modes are shown in table 12.3.

Table 12.3 A/D Converter Operation Modes

| Operation Mode | Reset | Active | Sleep | Watch | Subactive | Subsleep | Standby | Module Standby |
|----------------|-------|-----------|-----------|-------|-----------|----------|---------|----------------|
| AMR | Reset | Functions | Functions | Held | Held | Held | Held | Held |
| ADSR | Reset | Functions | Functions | Held | Held | Held | Held | Held |
| ADRRH | Held* | Functions | Functions | Held | Held | Held | Held | Held |
| ADRRL | Held* | Functions | Functions | Held | Held | Held | Held | Held |

Note: * Undefined in a power-on reset.

12.4 Interrupts

When A/D conversion ends (ADSF changes from 1 to 0), bit IRRAD in interrupt request register 2 (IRR2) is set to 1.

A/D conversion end interrupts can be enabled or disabled by means of bit IENAD in interrupt enable register 2 (IENR2).

For further details see 3.3, Interrupts.

12.5 Typical Use

An example of how the A/D converter can be used is given below, using channel 1 (pin AN₁) as the analog input channel. Figure 12.3 shows the operation timing.

1. Bits CH3 to CH0 of the A/D mode register (AMR) are set to 0101, making pin AN₁ the analog input channel. A/D interrupts are enabled by setting bit IENAD to 1, and A/D conversion is started by setting bit ADSF to 1.
2. When A/D conversion is complete, bit IRRAD is set to 1, and the A/D conversion result is stored in ADRRH and ADRRL. At the same time ADSF is cleared to 0, and the A/D converter goes to the idle state.
3. Bit IENAD = 1, so an A/D conversion end interrupt is requested.
4. The A/D interrupt handling routine starts.
5. The A/D conversion result is read and processed.
6. The A/D interrupt handling routine ends.

If ADSF is set to 1 again afterward, A/D conversion starts and steps 2 through 6 take place.

Figures 12.4 and 12.5 show flow charts of procedures for using the A/D converter.

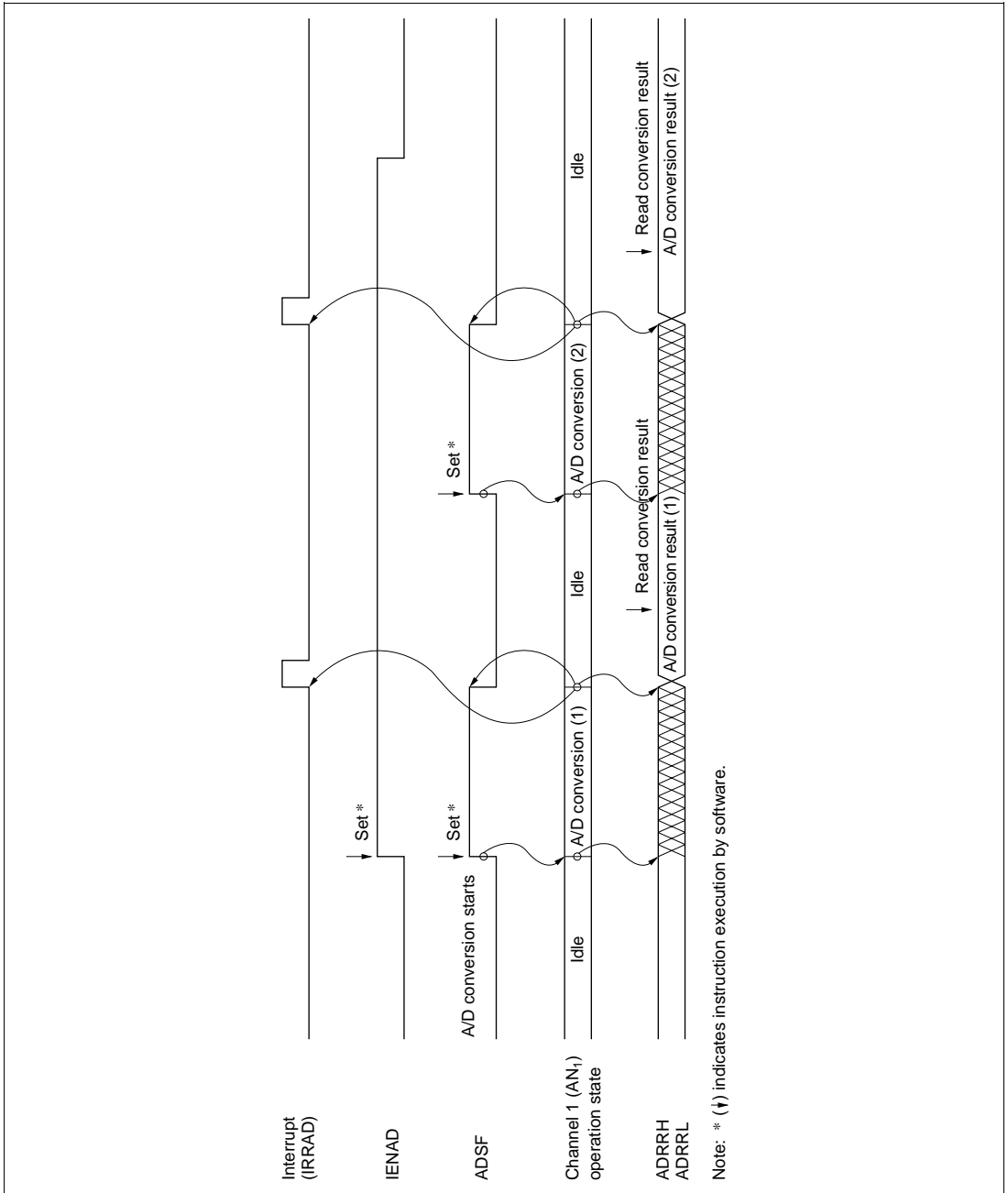

Figure 12.3 Typical A/D Converter Operation Timing

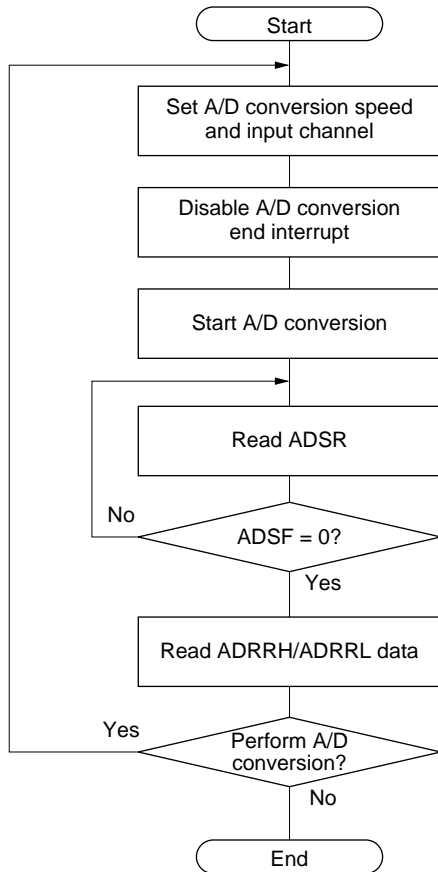

Figure 12.4 Flow Chart of Procedure for Using A/D Converter (Polling by Software)

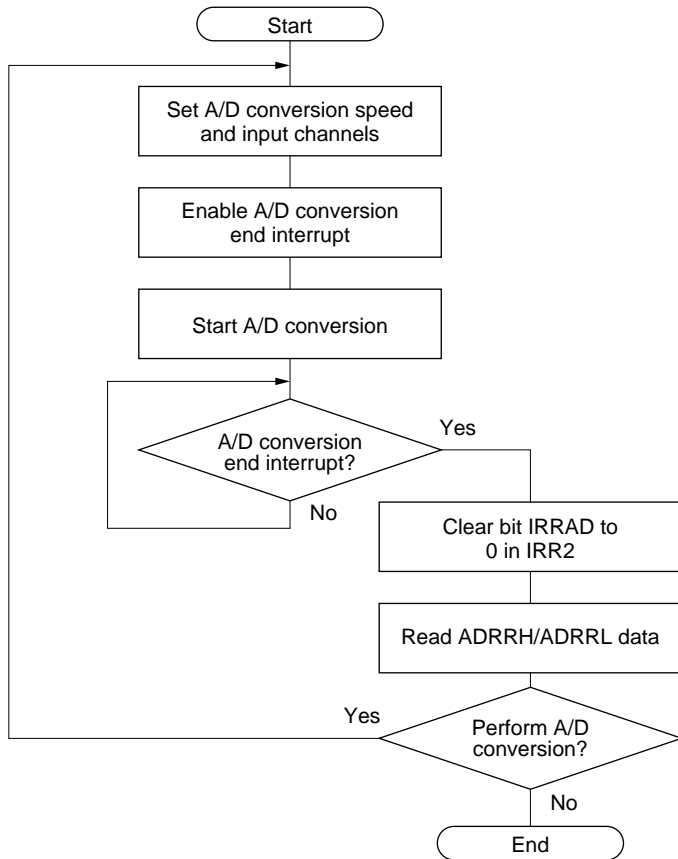

Figure 12.5 Flow Chart of Procedure for Using A/D Converter (Interrupts Used)

12.6 Application Notes

- Data in ADRRH and ADRRL should be read only when the A/D start flag (ADSF) in the A/D start register (ADSR) is cleared to 0.
- Changing the digital input signal at an adjacent pin during A/D conversion may adversely affect conversion accuracy.
- When A/D conversion is started after clearing module standby mode, wait for 10 ϕ clock cycles before starting.

Section 13 LCD Controller/Driver

13.1 Overview

The H8/3867 Series and H8/3827 Series has an on-chip segment type LCD control circuit, LCD driver, and power supply circuit, enabling it to directly drive an LCD panel.

13.1.1 Features

1. Features

Features of the LCD controller/driver are given below.

- Display capacity

| Duty Cycle | Internal Driver | Segment External Expansion Driver |
|------------|-----------------|-----------------------------------|
| Static | 32 seg | 256 seg |
| 1/2 | 32 seg | 128 seg |
| 1/3 | 32 seg | 64 seg |
| 1/4 | 32 seg | 64 seg |

- LCD RAM capacity
8 bits × 32 bytes (256 bits)
- Word access to LCD RAM
- All eight segment output pins can be used individually as port pins.
- Common output pins not used because of the duty cycle can be used for common double-buffering (parallel connection).
- Display possible in operating modes other than standby mode
- Choice of 11 frame frequencies
- Built-in power supply split-resistance, supplying LCD drive power
- Use of module standby mode enables this module to be placed in standby mode independently when not used.
- Built-in step-up constant-voltage (5 V) power supply allows LCD display even at low voltages. (H8/3867 Series)
- A or B waveform selectable by software

13.1.2 Block Diagram

Figure 13.1 shows a block diagram of the LCD controller/driver.

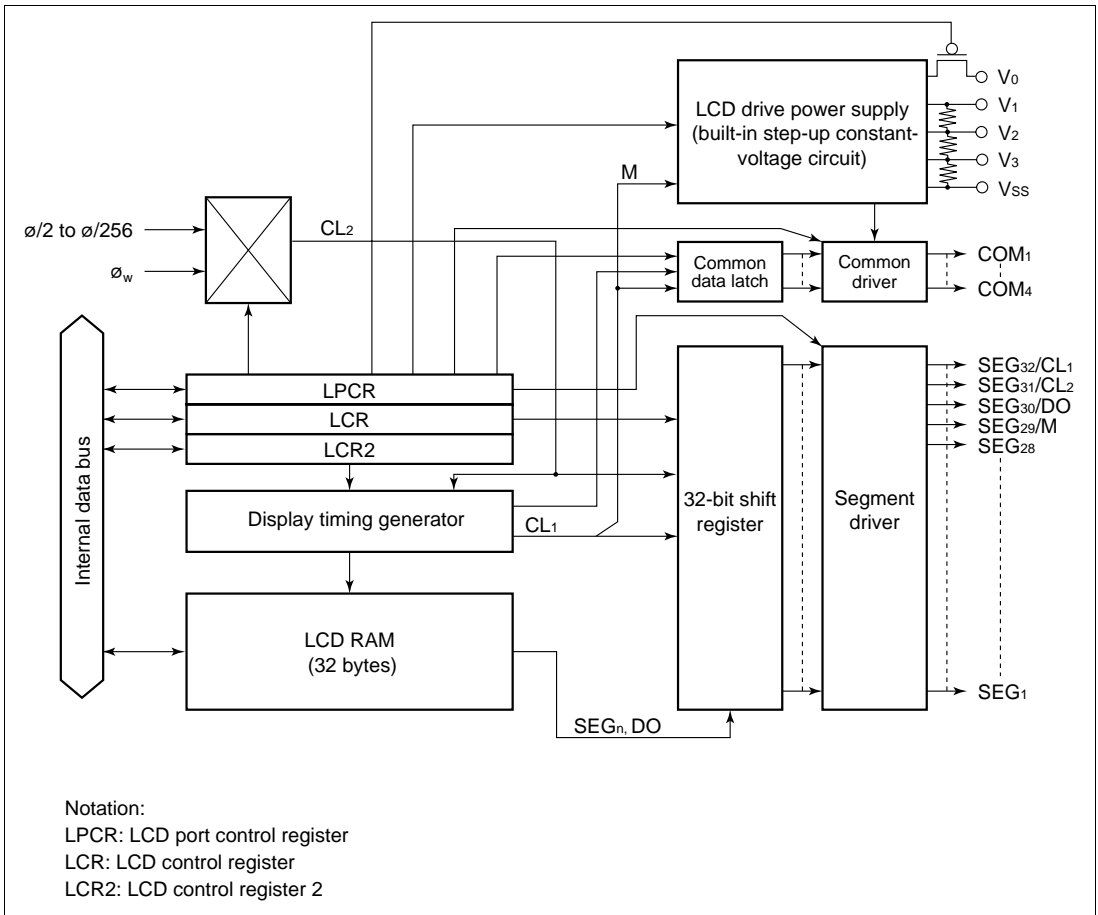

Figure 13.1 Block Diagram of LCD Controller/Driver

13.1.3 Pin Configuration

Table 13.1 shows the LCD controller/driver pin configuration.

Table 13.1 Pin Configuration

| Name | Abbrev. | I/O | Function |
|---|---|--------|---|
| Segment output pins | SEG ₃₂ to SEG ₁ | Output | LCD segment drive pins All pins are multiplexed as port pins (setting programmable) |
| Common output pins | COM ₄ to COM ₁ | Output | LCD common drive pins Pins can be used in parallel with static or 1/2 duty |
| Segment external expansion signal pins | CL ₁ | Output | Display data latch clock, multiplexed as SEG ₃₂ |
| | CL ₂ | Output | Display data shift clock, multiplexed as SEG ₃₁ |
| | M | Output | LCD alternation signal, multiplexed as SEG ₂₉ |
| | DO | Output | Serial display data, multiplexed as SEG ₃₀ |
| LCD power supply pins | V ₀ , V ₁ , V ₂ , V ₃ | — | Used when a bypass capacitor is connected externally, and when an external power supply circuit is used |

13.1.4 Register Configuration

Table 13.2 shows the register configuration of the LCD controller/driver.

Table 13.2 LCD Controller/Driver Registers

| Name | Abbrev. | R/W | Initial Value | Address |
|---------------------------|---------|-----|---------------|----------------|
| LCD port control register | LPCR | R/W | H'00 | H'FFC0 |
| LCD control register | LCR | R/W | H'80 | H'FFC1 |
| LCD control register 2 | LCR2 | R/W | H'60 | H'FFC2 |
| LCD RAM | — | R/W | Undefined | H'F740, H'F75F |
| Clock stop register 2 | CKSTPR2 | R/W | H'FF | H'FFFB |

13.2 Register Descriptions

13.2.1 LCD Port Control Register (LPCR)

| | | | | | | | | |
|---------------|------|------|-----|-----|------|------|------|------|
| Bit | 7 | 6 | 5 | 4 | 3 | 2 | 1 | 0 |
| | DTS1 | DTS0 | CMX | SGX | SGS3 | SGS2 | SGS1 | SGS0 |
| Initial value | 0 | 0 | 0 | 0 | 0 | 0 | 0 | 0 |
| Read/Write | R/W | R/W | R/W | R/W | R/W | R/W | R/W | R/W |

LPCR is an 8-bit read/write register which selects the duty cycle and LCD driver pin functions.

LPCR is initialized to H'00 upon reset.

Bits 7 to 5: Duty cycle select 1 and 0 (DTS1, DTS0), common function select (CMX)

The combination of DTS1 and DTS0 selects static, 1/2, 1/3, or 1/4 duty. CMX specifies whether or not the same waveform is to be output from multiple pins to increase the common drive power when not all common pins are used because of the duty setting.

| Bit 7 DTS1 | Bit 6 DTS0 | Bit 5 CMX | Duty Cycle | Common Drivers | Notes |
|---------------|---------------|--------------|------------|--------------------------------------|---|
| 0 | 0 | 0 | Static | COM ₁ (initial value) | Do not use COM ₄ , COM ₃ , and COM ₂ . |
| | | 1 | | COM ₄ to COM ₁ | COM ₄ , COM ₃ , and COM ₂ output the same waveform as COM ₁ . |
| 0 | 1 | 0 | 1/2 duty | COM ₂ to COM ₁ | Do not use COM ₄ and COM ₃ . |
| | | 1 | | COM ₄ to COM ₁ | COM ₄ outputs the same waveform as COM ₃ , and COM ₂ outputs the same waveform as COM ₁ . |
| 1 | 0 | 0 | 1/3 duty | COM ₃ to COM ₁ | Do not use COM ₄ . |
| | | 1 | | COM ₄ to COM ₁ | Do not use COM ₄ . |
| 1 | 1 | 0 | 1/4 duty | COM ₄ to COM ₁ | — |
| | | 1 | | | |

Bit 4: Expansion signal select (SGX)

Bit 4 selects whether the SEG₃₂/CL₁, SEG₃₁/CL₂, SEG₃₀/DO, and SEG₂₉/M pins are used as segment pins (SEG₃₂ to SEG₂₉) or as segment external expansion pins (CL₁, CL₂, DO, M).

Bit 4

| SGX | Description |
|-----|---|
| 0 | Pins SEG ₃₂ to SEG ₂₉ * (Initial value) |
| 1 | Pins CL ₁ , CL ₂ , DO, M |

Note: * These pins function as ports when the setting of SGS3 to SGS0 is 0000 or 0001.

Bit 3: Segment driver select 3 to 0 (SGS3 to SGS0)

Bits 3 to 0 select the segment drivers to be used.

| Bit 4 SGX | Bit 3 SGS3 | Bit 2 SGS2 | Bit 1 SGS1 | Bit 0 SGS0 | Function of Pins SEG ₃₂ to SEG ₁ | | | | Notes |
|--------------|---------------|---------------|---------------|---------------|--|---|--|---|-----------------|
| | | | | | SEG ₃₂ to SEG ₂₅ | SEG ₂₄ to SEG ₁₇ | SEG ₁₆ to SEG ₉ | SEG ₈ to SEG ₁ | |
| 0 | 0 | 0 | 0 | 0 | Port | Port | Port | Port | (Initial value) |
| | 0 | 0 | 0 | 1 | Port | Port | Port | Port | |
| | 0 | 0 | 1 | * | SEG | Port | Port | Port | |
| | 0 | 1 | 0 | * | SEG | SEG | Port | Port | |
| | 0 | 1 | 1 | * | SEG | SEG | SEG | Port | |
| | 1 | * | * | * | SEG | SEG | SEG | SEG | |
| 1 | 0 | 0 | 0 | 0 | Port* | Port | Port | Port | |
| | * | * | * | * | Setting prohibited | | | | |

*: Don't care

Note: * SEG₃₂ to SEG₂₉ are external expansion pins.

13.2.2 LCD Control Register (LCR)

| | | | | | | | | |
|---------------|---|-----|-----|------|------|------|------|------|
| Bit | 7 | 6 | 5 | 4 | 3 | 2 | 1 | 0 |
| | — | PSW | ACT | DISP | CKS3 | CKS2 | CKS1 | CKS0 |
| Initial value | 1 | 0 | 0 | 0 | 0 | 0 | 0 | 0 |
| Read/Write | — | R/W | R/W | R/W | R/W | R/W | R/W | R/W |

LCR is an 8-bit read/write register which performs LCD drive power supply on/off control and display data control, and selects the frame frequency.

LCR is initialized to H'80 upon reset.

Bit 7: Reserved bit

Bit 7 is reserved; it is always read as 1 and cannot be modified.

Bit 6: LCD drive power supply on/off control (PSW)

Bit 6 can be used to turn the LCD drive power supply off when LCD display is not required in a power-down mode, or when an external power supply is used. When the ACT bit is cleared to 0, or in standby mode, the LCD drive power supply is turned off regardless of the setting of this bit.

Bit 6

PSW

Description

| | | |
|---|----------------------------|-----------------|
| 0 | LCD drive power supply off | (initial value) |
| 1 | LCD drive power supply on | |

Bit 5: Display function activate (ACT)

Bit 5 specifies whether or not the LCD controller/driver is used. Clearing this bit to 0 halts operation of the LCD controller/driver. The LCD drive power supply is also turned off, regardless of the setting of the PSW bit. However, register contents are retained.

Bit 5

ACT

Description

| | | |
|---|--|-----------------|
| 0 | LCD controller/driver operation halted | (initial value) |
| 1 | LCD controller/driver operates | |

Bit 4: Display data control (DISP)

Bit 4 specifies whether the LCD RAM contents are displayed or blank data is displayed regardless of the LCD RAM contents.

Bit 4

| DISP | Description |
|------|---|
| 0 | Blank data is displayed (initial value) |
| 1 | LCD RAM data is display |

Bits 3 to 0: Frame frequency select 3 to 0 (CKS3 to CKS0)

Bits 3 to 0 select the operating clock and the frame frequency. In subactive mode, watch mode, and subsleep mode, the system clock (ϕ) is halted, and therefore display operations are not performed if one of the clocks from $\phi/2$ to $\phi/256$ is selected. If LCD display is required in these modes, ϕw , $\phi w/2$, or $\phi w/4$ must be selected as the operating clock.

| Bit 3 CKS3 | Bit 2 CKS2 | Bit 1 CKS1 | Bit 0 CKS0 | Operating Clock | Frame Frequency* ² | |
|---------------|---------------|---------------|---------------|-----------------|--------------------------------------|--------------------------------|
| | | | | | $\phi = 2$ MHz | $\phi = 250$ kHz* ¹ |
| 0 | * | 0 | 0 | ϕw | 128 Hz* ³ (initial value) | |
| 0 | * | 0 | 1 | $\phi w/2$ | 64 Hz* ³ | |
| 0 | * | 1 | * | $\phi w/4$ | 32 Hz* ³ | |
| 1 | 0 | 0 | 0 | $\phi/2$ | — | 244 Hz |
| 1 | 0 | 0 | 1 | $\phi/4$ | 977 Hz | 122 Hz |
| 1 | 0 | 1 | 0 | $\phi/8$ | 488 Hz | 61 Hz |
| 1 | 0 | 1 | 1 | $\phi/16$ | 244 Hz | 30.5 Hz |
| 1 | 1 | 0 | 0 | $\phi/32$ | 122 Hz | — |
| 1 | 1 | 0 | 1 | $\phi/64$ | 61 Hz | — |
| 1 | 1 | 1 | 0 | $\phi/128$ | 30.5 Hz | — |
| 1 | 1 | 1 | 1 | $\phi/256$ | — | — |

*: Don't care

- Notes: 1. This is the frame frequency in active (medium-speed, $\phi_{osc}/16$) mode when $\phi = 2$ MHz.
 2. When 1/3 duty is selected, the frame frequency is 4/3 times the value shown.
 3. This is the frame frequency when $\phi w = 32.768$ kHz.

13.2.3 LCD Control Register 2 (LCR2)

| | | | | | | | | |
|---------------|-------|---|---|------|------|------|------|------|
| Bit | 7 | 6 | 5 | 4 | 3 | 2 | 1 | 0 |
| | LCDAB | — | — | SUPS | CDS3 | CDS2 | CDS1 | CDS0 |
| Initial value | 0 | 1 | 1 | 0 | 0 | 0 | 0 | 0 |
| Read/Write | R/W | — | — | R/W | R/W | R/W | R/W | R/W |

LCR2 is an 8-bit read/write register which controls switching between the A waveform and B waveform, selects the drive power supply, controls the step-up constant-voltage (5 V) power supply, and selects the duty cycle of the charge/discharge pulses which control disconnection of the power supply split-resistance from the power supply circuit.

LCR2 is initialized to H'60 upon reset.

Bit 7: A waveform/B waveform switching control (LCDAB)

Bit 7 specifies whether the A waveform or B waveform is used as the LCD drive waveform.

Bit 7

| LCDAB | Description |
|-------|--|
| 0 | Drive using A waveform (initial value) |
| 1 | Drive using B waveform |

Bits 6 and 5: Reserved bits

Bits 6 and 5 are reserved; they are always read as 1 and cannot be modified.

Bit 4: Drive power supply select, step-up constant-voltage (5 V) power supply control (SUPS) (Applies to the H8/3867 Series only)

When V_{CC} is selected as the drive power supply, the step-up constant-voltage (5 V) power supply simultaneously stops operating; when 5 V is selected as the drive power supply, the step-up constant-voltage (5 V) power supply simultaneously operates.

Bit 4

| SUPS | Description |
|------|--|
| 0 | Drive power supply is V_{CC} , step-up constant-voltage (5 V) power supply halts (Initial value) |
| 1 | Drive power supply is 5 V, step-up constant-voltage (5 V) power supply operates |

Bits 3 to 0: Charge/discharge pulse duty cycle select (CDS3 to CDS0)

| Bit 3 CDS3 | Bit 2 CDS2 | Bit 1 CDS1 | Bit 0 CDS0 | Duty Cycle | Notes |
|---------------|---------------|---------------|---------------|------------|----------------------------|
| 0 | 0 | 0 | 0 | 1 | Fixed high (initial value) |
| 0 | 0 | 0 | 1 | 1/8 | |
| 0 | 0 | 1 | 0 | 2/8 | |
| 0 | 0 | 1 | 1 | 3/8 | |
| 0 | 1 | 0 | 0 | 4/8 | |
| 0 | 1 | 0 | 1 | 5/8 | |
| 0 | 1 | 1 | 0 | 6/8 | |
| 0 | 1 | 1 | 1 | 0 | Fixed low |
| 1 | 0 | * | * | 1/16 | |
| 1 | 1 | * | * | 1/32 | |

*: Don't care

Bits 3 to 0 select the duty cycle while the power supply split-resistance is connected to the power supply circuit.

When a 0 duty cycle is selected, the power supply split-resistance is permanently disconnected from the power supply circuit, so power should be supplied to pins V1, V2, and V3 by an external circuit.

Figure 13.2 shows the waveform of the charge/discharge pulses. The duty cycle is T_c/T_w .

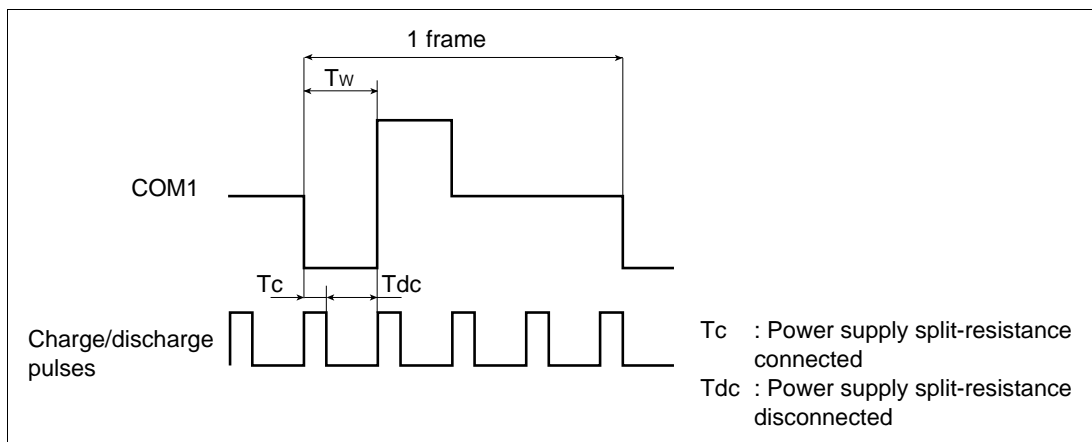

Figure 13.2 Example of A Waveform with 1/2 Duty and 1/2 Bias

13.2.4 Clock Stop Register 2 (CKSTPR2)

| | | | | | | | | |
|---------------|---|---|---|---|---------|---------|---------|---------|
| Bit | 7 | 6 | 5 | 4 | 3 | 2 | 1 | 0 |
| | — | — | — | — | AECKSTP | WDCKSTP | PWCKSTP | LDCKSTP |
| Initial value | 1 | 1 | 1 | 1 | 1 | 1 | 1 | 1 |
| Read/Write | — | — | — | — | R/W | R/W | R/W | R/W |

CKSTPR2 is an 8-bit read/write register that performs module standby mode control for peripheral modules. Only the bit relating to the LCD controller/driver is described here. For details of the other bits, see the sections on the relevant modules.

Bit 0: LCD controller/driver module standby mode control (LDCKSTP)

Bit 0 controls setting and clearing of module standby mode for the LCD controller/driver.

Bit 0

| LDCKSTP | Description |
|---------|-------------|
|---------|-------------|

| | |
|---|--|
| 0 | LCD controller/driver is set to module standby mode |
| 1 | LCD controller/driver module standby mode is cleared (initial value) |

13.3 Operation

13.3.1 Settings up to LCD Display

To perform LCD display, the hardware and software related items described below must first be determined.

1. Hardware settings

a. Using 1/2 duty

When 1/2 duty is used, interconnect pins V_2 and V_3 as shown in figure 13.3.

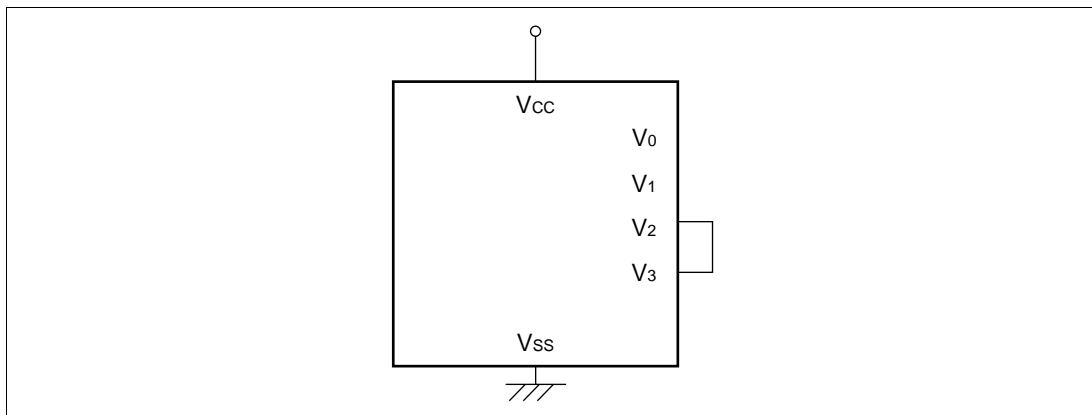

Figure 13.3 Handling of LCD Drive Power Supply when Using 1/2 Duty

b. Large-panel display

As the impedance of the built-in power supply split-resistance is large, it may not be suitable for driving a large panel. If the display lacks sharpness when using a large panel, refer to section 13.3.7, Boosting the LCD Drive Power Supply. When static or 1/2 duty is selected, the common output drive capability can be increased. Set CMX to 1 when selecting the duty cycle. In this mode, with a static duty cycle pins COM₄ to COM₁ output the same waveform, and with 1/2 duty the COM₁ waveform is output from pins COM₂ and COM₁, and the COM₂ waveform is output from pins COM₄ and COM₃.

c. Luminance adjustment function (V_0 pin)

Connecting a resistance between the V_0 and V_1 pins enables the luminance to be adjusted. For details, see 13.3.3, Luminance Adjustment Function (V_0 Pin).

d. LCD drive power supply setting

With the H8/3867 Series, there are two ways of providing LCD power: by using the on-chip power supply circuit, or by using an external circuit. With the H8/3867 Series, the on-chip power supply circuit allows the selection of either the power supply voltage (V_{CC}) or a step-up constant voltage (5 V). For details of the step-up constant-voltage power supply, see 13.3.4, Step-Up Constant-Voltage (5 V) Power Supply.

When the on-chip power supply circuit is used for the LCD drive power supply, the V_0 and V_1 pins should be interconnected externally, as shown in figure 13.4 (a).

When an external power supply circuit is used for the LCD drive power supply, connect the external power supply to the V_1 pin, and short the V_0 pin to V_{CC} externally, as shown in figure 13.4 (b).

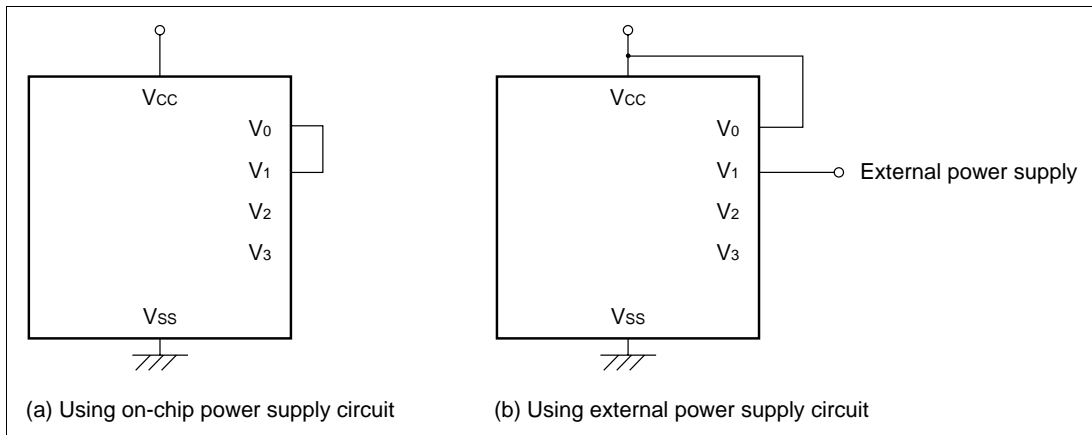

Figure 13.4 Examples of LCD Power Supply Pin Connections

e. Low-power-consumption LCD drive system

Use of a low-power-consumption LCD drive system enables the power consumption required for LCD drive to be optimized. For details, see 13.3.5, Low-Power-Consumption LCD Drive System.

f. Segment external expansion

The number of segments can be increased by connecting an HD66100 externally. For details, see section 13.3.8, Connection to HD66100.

2. Software settings

a. Duty selection

Any of four duty cycles—static, 1/2 duty, 1/3 duty, or 1/4 duty—can be selected with bits DTS1 and DTS0.

b. Segment selection

The segment drivers to be used can be selected with bits SGS₃ to SGS₀.

c. Frame frequency selection

The frame frequency can be selected by setting bits CKS₃ to CKS₀. The frame frequency should be selected in accordance with the LCD panel specification. For the clock selection method in watch mode, subactive mode, and subsleep mode, see 13.3.6, Operation in Power-Down Modes.

d. A or B waveform selection

Either the A or B waveform can be selected as the LCD waveform to be used by means of LCDAB.

e. LCD drive power supply selection

When the on-chip power supply circuit is used, the power supply to be used can be selected with the SUPS bit. When an external power supply circuit is used, select V_{CC} with the SUPS bit and turn the LCD drive power supply off with the PSW bit.

13.3.2 Relationship between LCD RAM and Display

The relationship between the LCD RAM and the display segments differs according to the duty cycle. LCD RAM maps for the different duty cycles when segment external expansion is not used are shown in figures 13.5 to 13.8, and LCD RAM maps when segment external expansion is used in figures 13.9 to 13.12.

After setting the registers required for display, data is written to the part corresponding to the duty cycle using the same kind of instruction as for ordinary RAM, and display is started automatically when turned on. Word- or byte-access instructions can be used for RAM setting.

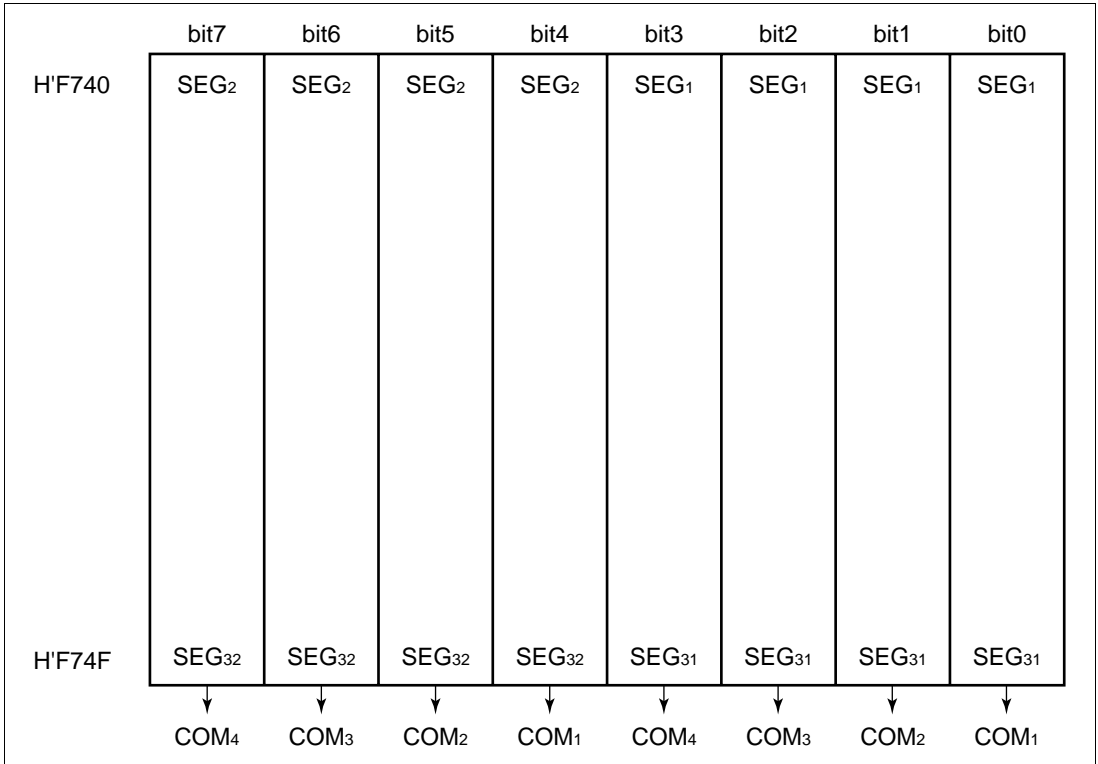

Figure 13.5 LCD RAM Map when Not Using Segment External Expansion (1/4 Duty)

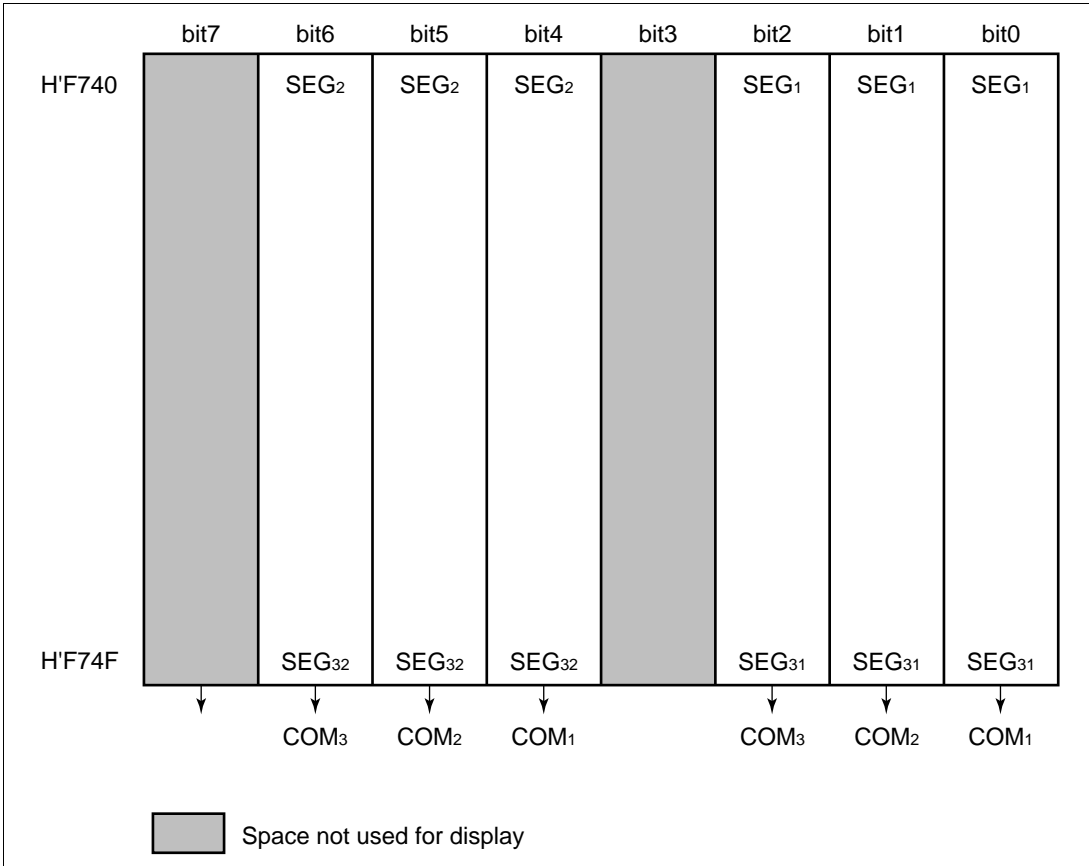

Figure 13.6 LCD RAM Map when Not Using Segment External Expansion (1/3 Duty)

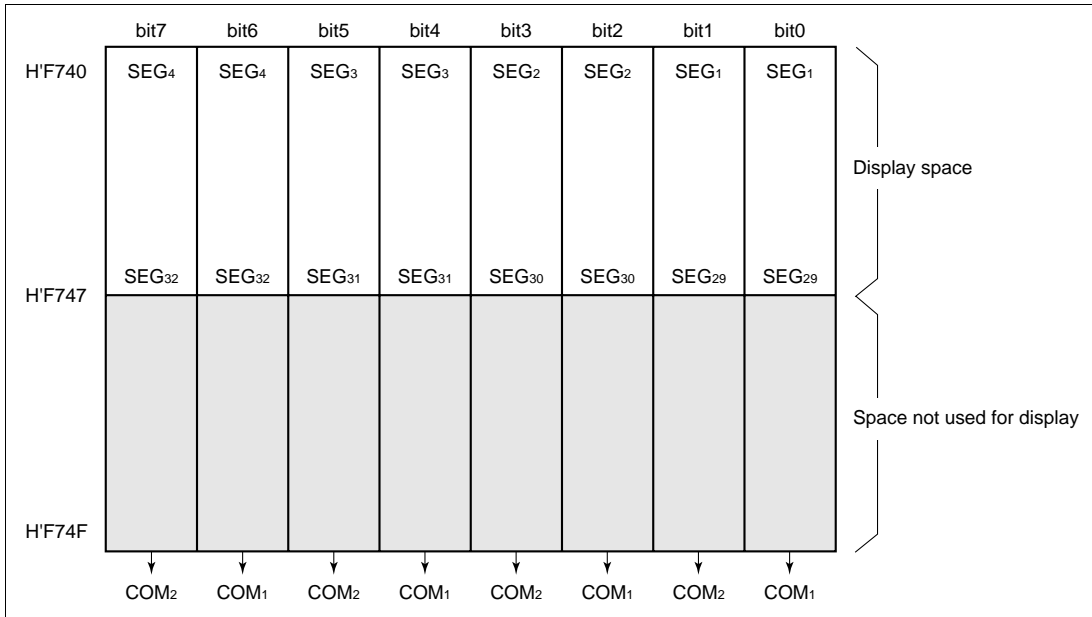

Figure 13.7 LCD RAM Map when Not Using Segment External Expansion (1/2 Duty)

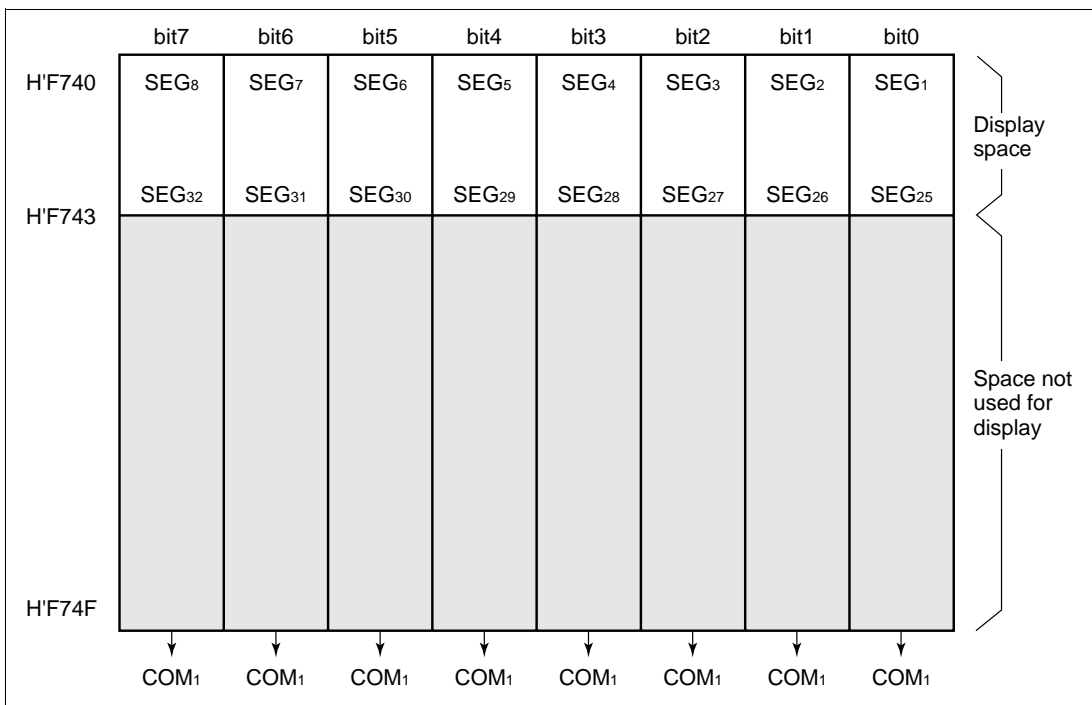

Figure 13.8 LCD RAM Map when Not Using Segment External Expansion (Static Mode)

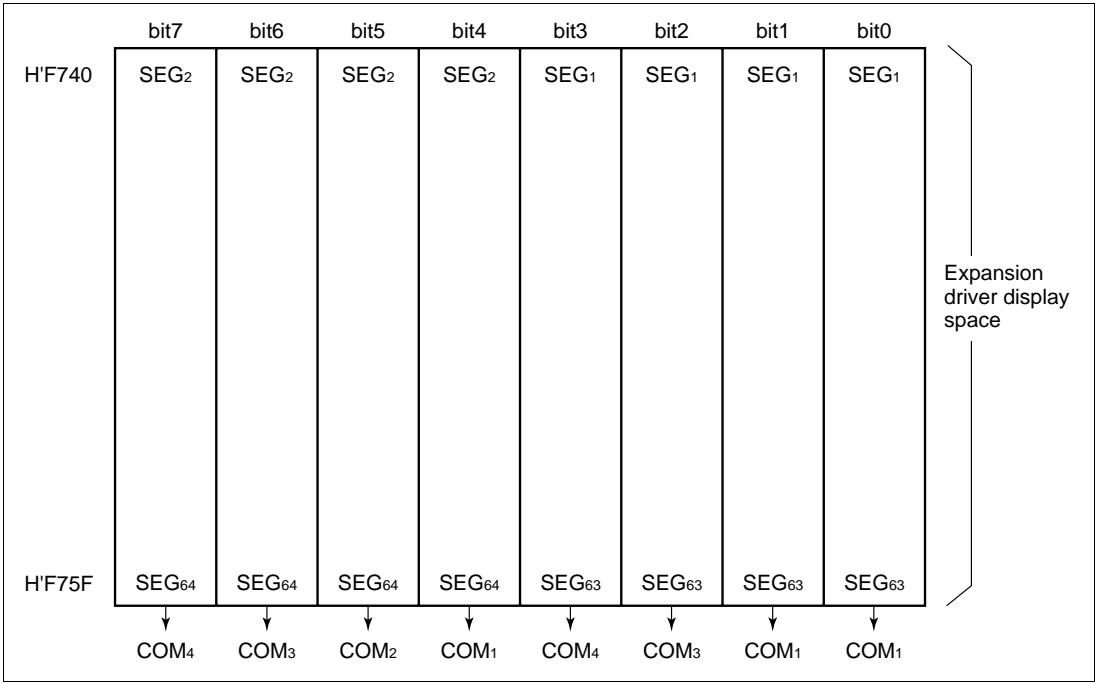

Figure 13.9 LCD RAM Map when Using Segment External Expansion (SGX = "1", SGS3 to SGS0 = "0000" 1/4 Duty)

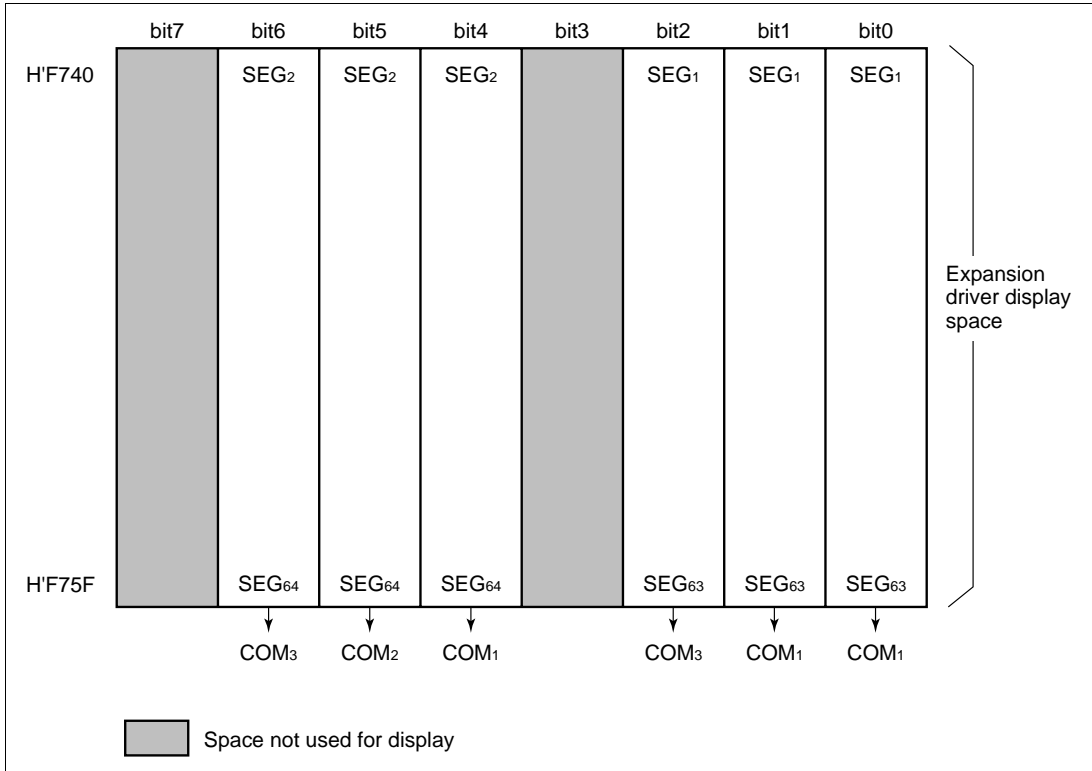

Figure 13.10 LCD RAM Map when Using Segment External Expansion (SGX = "1", SGS3 to SGS0 = "0000" 1/3 Duty)

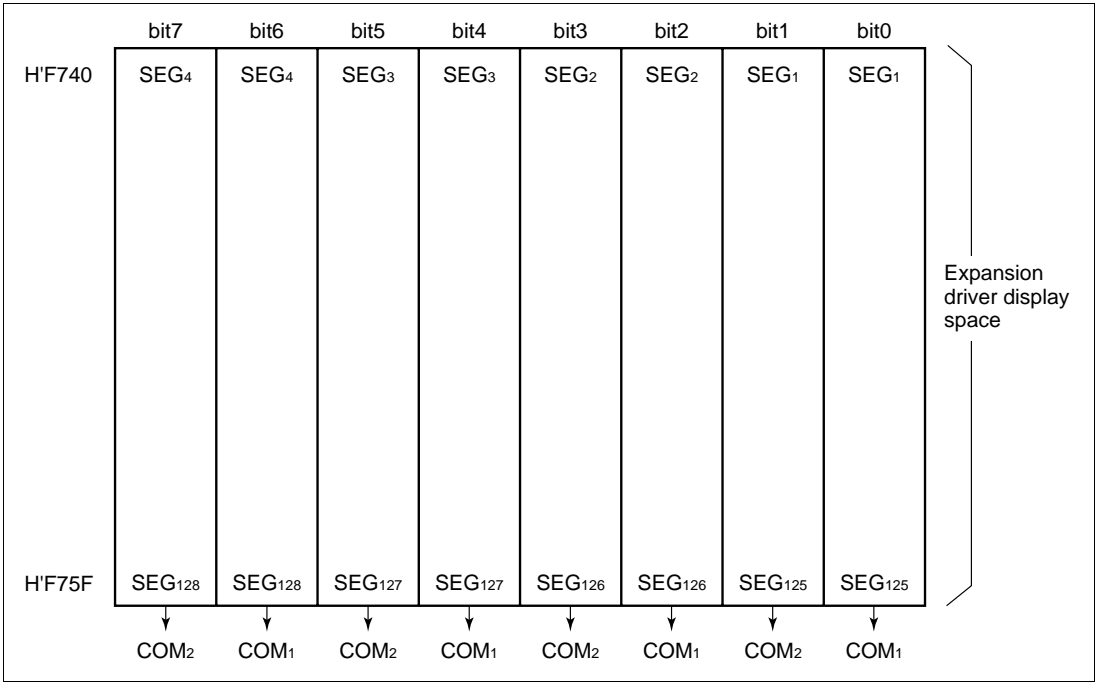

Figure 13.11 LCD RAM Map when Using Segment External Expansion (SGX = "1", SGS3 to SGS0 = "0000" 1/2 Duty)

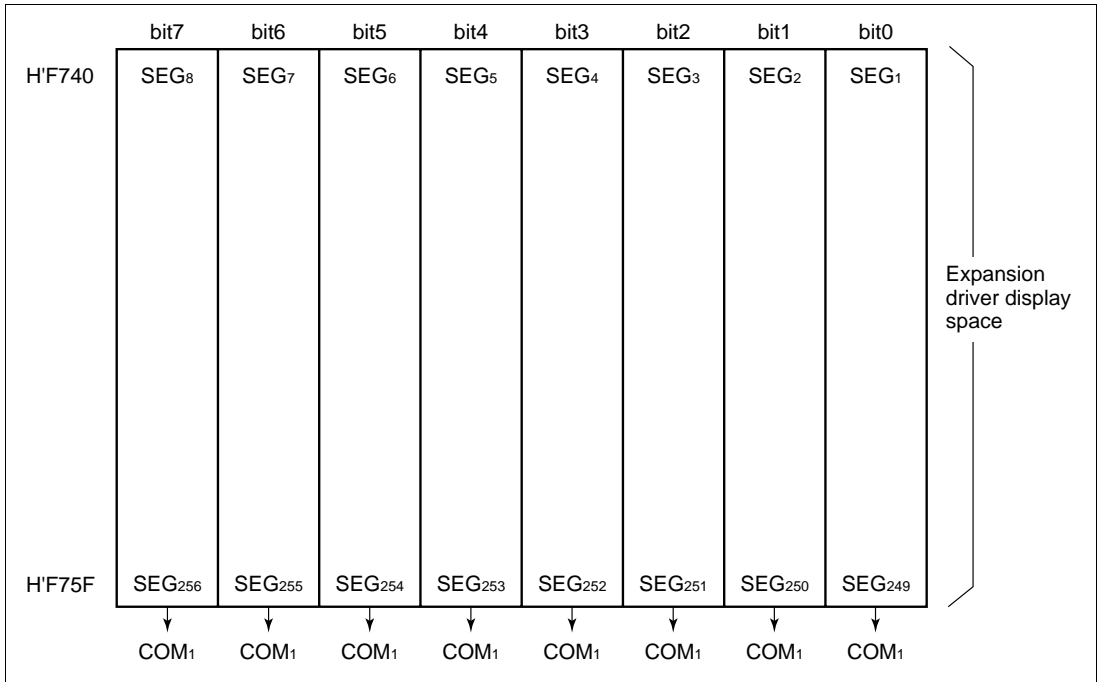

Figure 13.12 LCD RAM Map when Using Segment External Expansion (SGX = "1", SGS3 to SGS0 = "0000" Static)

13.3.3 Luminance Adjustment Function (V0 Pin)

Figure 13.13 shows a detailed block diagram of the LCD drive power supply unit.

The voltage output to the V_0 pin is either V_{CC} or the 5 V output from the step-up conversion power supply circuit. When either of these voltages is used directly as the LCD drive power supply, the V_0 and V_1 pins should be shorted. Also, connecting a variable resistance, R , between the V_0 and V_1 pins makes it possible to adjust the voltage applied to the V_1 pin, and so to provide luminance adjustment for the LCD panel.

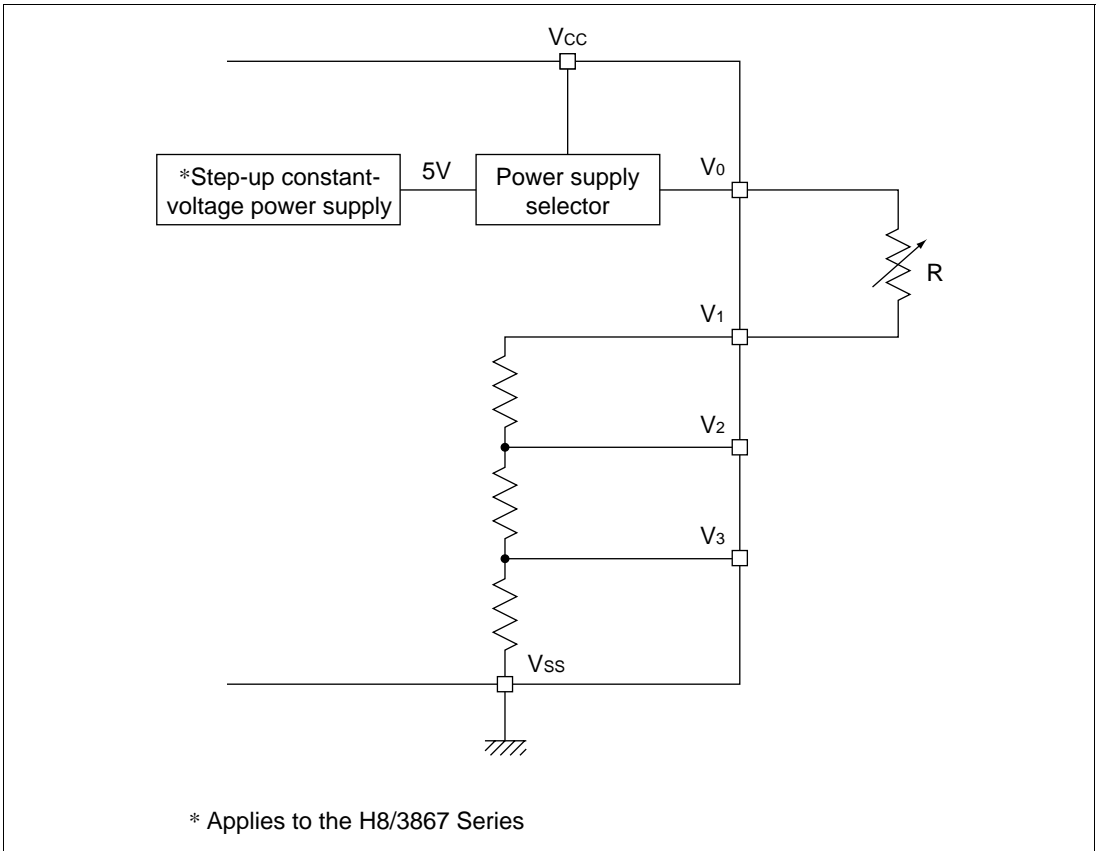

Figure 13.13 LCD Drive Power Supply Unit

13.3.4 Step-Up Constant-Voltage (5 V) Power Supply

The H8/3867 Series has an on-chip step-up constant-voltage (5 V) power supply which enables a 5 V constant voltage to be obtained independently of V_{CC} . This feature is not provided in the H8/3827 Series.

When the SUPS bit is set to 1 in LCD control register 2 (LCR2), the step-up constant-voltage (5 V) power supply operates, and a 5 V constant voltage is output from the V_0 pin. Either short the V_0 and V_1 pins or connect a resistance to divide the voltage.

Note: The step-up constant-voltage (5 V) power supply must not be used for any purpose other than the H8/3864 Series' LCD drive power supply. When a large panel is driven, the power supply capacity may be insufficient. In this case, either use V_{CC} as the power supply or use an external power supply circuit.

13.3.5 Low-Power-Consumption LCD Drive System

The use of the built-in split-resistance is normally the easiest method for implementing the LCD power supply circuit, but since the built-in resistance is fixed, a certain direct current flows constantly from the built-in resistance's V_{CC} to V_{SS} . As this current does not depend on the current dissipation of the LCD panel, if an LCD panel with a small current dissipation is used, a wasteful amount of power will be consumed. The H8/3864 Series is equipped with a function to minimize this waste of power. Use of this function makes it possible to achieve the optimum power supply circuit for the LCD panel's current dissipation.

1. Principles

- a. Capacitors are connected as external circuits to LCD power supply pins V_1 , V_2 , and V_3 , as shown in figure 13.14.
- b. The capacitors connected to V_1 , V_2 , and V_3 are repeatedly charged and discharged in the cycle shown in figure 13.14, maintaining the potentials.
- c. At this time, the charged potential is a potential corresponding to the V_1 , V_2 , and V_3 pins, respectively. (For example, with 1/3 bias drive, the charge for V_2 is 2/3 that of V_1 , and that for V_3 is 1/3 that of V_1 .)
- d. Power is supplied to the LCD panel by means of the charges accumulated in these capacitors.
- e. The capacitances and charging/discharging periods of these capacitors are therefore determined by the current dissipation of the LCD panel.
- f. The charging and discharging periods can be selected by software.

2. Example of operation (with 1/3 bias drive)

- a. During charging period T_c in the figure, the potential is divided among pins V1, V2, and V3 by the built-in split-resistance (the potential of V2 being $2/3$ that of V1, and that of V3 being $1/3$ that of V1), as shown in figure 13.14, and external capacitors C1, C2, and C3 are charged. The LCD panel is continues to be driven during this time.
- b. In the following discharging period, T_{dc} , charging is halted and the charge accumulated in each capacitor is discharged, driving the LCD panel.
- c. At this time, a slight voltage drop occurs due to the discharging; optimum values must be selected for the charging period and the capacitor capacitances to ensure that this does not affect the driving of the LCD panel.
- d. In this way, the capacitors connected to V1, V2, and V3 are repeatedly charged and discharged in the cycle shown in figure 13.14, maintaining the potentials and continuously driving the LCD panel.
- e. As can be seen from the above description, the capacitances and charging/discharging periods of the capacitors are determined by the current dissipation of the LCD panel used. The charging/discharging periods can be selected with bits CDS3 to CDS0.
- f. The actual capacitor capacitances and charging/discharging periods must be determined experimentally in accordance with the current dissipation requirements of the LCD panel. An optimum current value can be selected, in contrast to the case in which a direct current flows constantly in the built-in split-resistance.

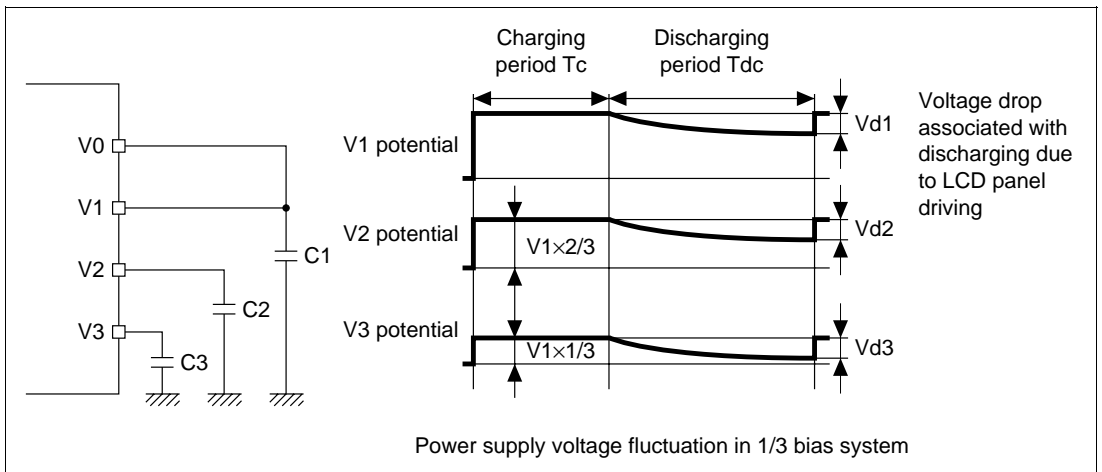

Figure 13.14 Example of Low-Power-Consumption LCD Drive Operation

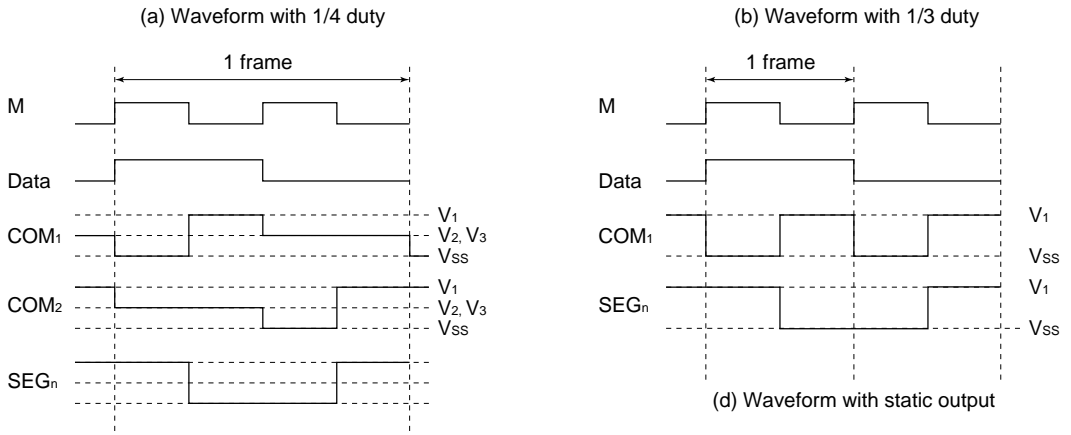
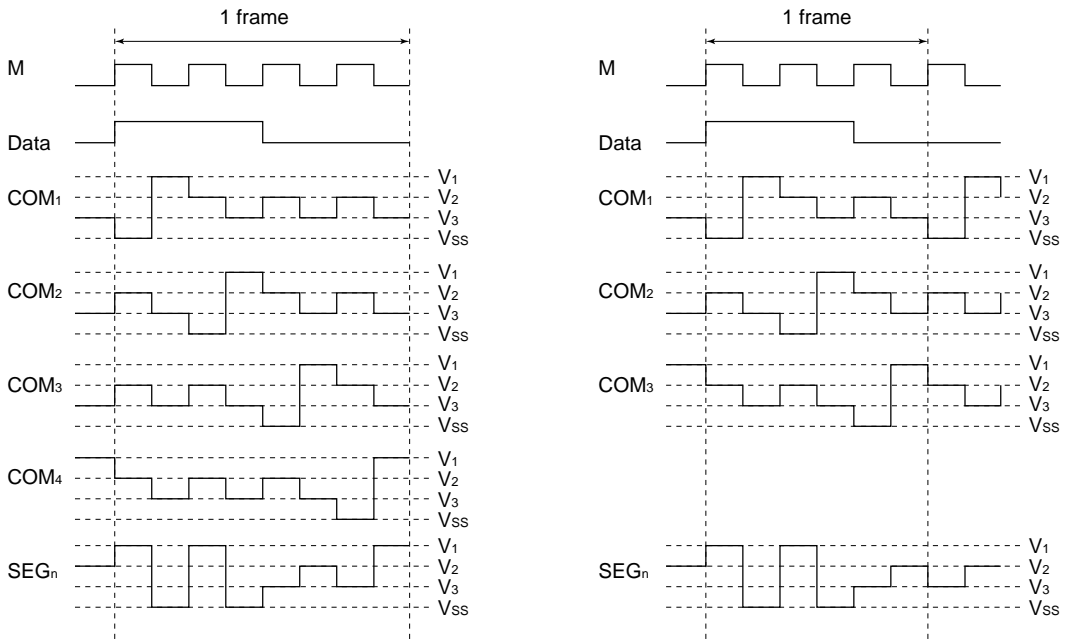
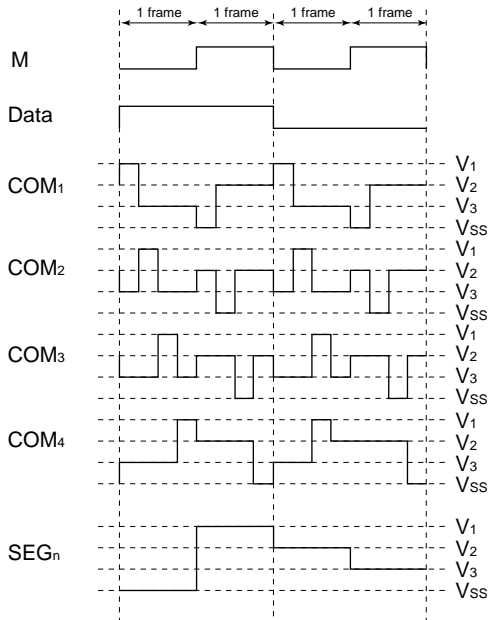
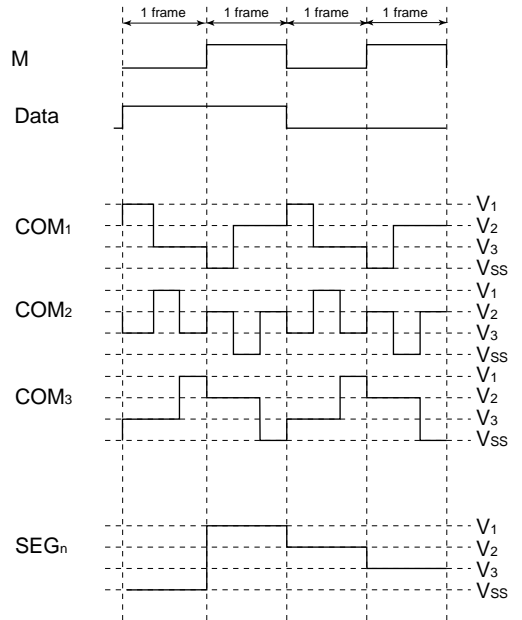

Figure 13.15 Output Waveforms for Each Duty Cycle (A Waveform)



(a) Waveform with 1/4 duty



(b) Waveform with 1/3 duty

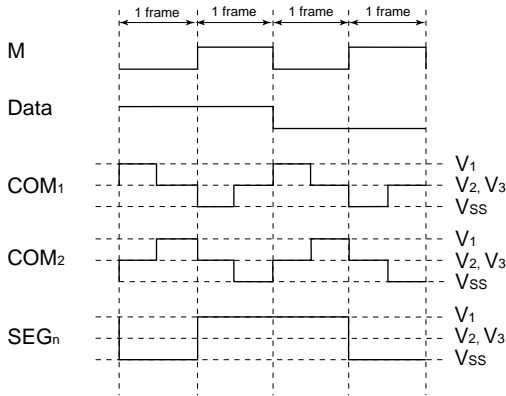

(c) Waveform with 1/2 duty

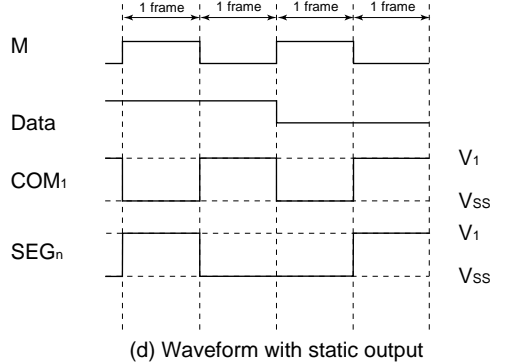

(d) Waveform with static output

Figure 13.16 Output Waveforms for Each Duty Cycle (B Waveform)

Table 13.3 Output Levels

| Data | | 0 | 0 | 1 | 1 |
|----------|----------------|------------|------------|----------|----------|
| M | | 0 | 1 | 0 | 1 |
| Static | Common output | V_1 | V_{SS} | V_1 | V_{SS} |
| | Segment output | V_1 | V_{SS} | V_{SS} | V_1 |
| 1/2 duty | Common output | V_2, V_3 | V_2, V_3 | V_1 | V_{SS} |
| | Segment output | V_1 | V_{SS} | V_{SS} | V_1 |
| 1/3 duty | Common output | V_3 | V_2 | V_1 | V_{SS} |
| | Segment output | V_2 | V_3 | V_{SS} | V_1 |
| 1/4 duty | Common output | V_3 | V_2 | V_1 | V_{SS} |
| | Segment output | V_2 | V_3 | V_{SS} | V_1 |

13.3.6 Operation in Power-Down Modes

In the H8/3867 Series, the LCD controller/driver can be operated even in the power-down modes. The operating state of the LCD controller/driver in the power-down modes is summarized in table 13.4.

In subactive mode, watch mode, and subsleep mode, the system clock oscillator stops, and therefore, unless ϕw , $\phi w/2$, or $\phi w/4$ has been selected by bits CKS3 to CKS0, the clock will not be supplied and display will halt. Since there is a possibility that a direct current will be applied to the LCD panel in this case, it is essential to ensure that ϕw , $\phi w/2$, or $\phi w/4$ is selected. In active (medium-speed) mode, the system clock is switched, and therefore CKS3 to CKS0 must be modified to ensure that the frame frequency does not change.

Table 13.4 Power-Down Modes and Display Operation

| Mode | | Reset | Active | Sleep | Watch | Sub-active | Sub-sleep | Standby | Module Standby |
|-------------------|-----------|-------|-----------|-----------|-------------------------|-------------------------|-------------------------|---------------------|---------------------|
| Clock | ϕ | Runs | Runs | Runs | Stops | Stops | Stops | Stops | Stops ^{*4} |
| | ϕw | Runs | Runs | Runs | Runs | Runs | Runs | Stops ^{*1} | Stops ^{*4} |
| Display operation | ACT = "0" | Stops | Stops | Stops | Stops | Stops | Stops | Stops ^{*2} | Stops |
| | ACT = "1" | Stops | Functions | Functions | Functions ^{*3} | Functions ^{*3} | Functions ^{*3} | Stops ^{*2} | Stops |

Notes: 1. The subclock oscillator does not stop, but clock supply is halted.

2. The LCD drive power supply is turned off regardless of the setting of the PSW bit.

3. Display operation is performed only if ϕw , $\phi w/2$, or $\phi w/4$ is selected as the operating clock.

4. The clock supplied to the LCD stops.

13.3.7 Boosting the LCD Drive Power Supply

When a large panel is driven, the on-chip power supply capacity may be insufficient. If the power supply capacity is insufficient when using the step-up constant power supply (5 V), either use V_{CC} as the power supply or use an external power supply circuit. If the power supply capacity is insufficient when V_{CC} is used as the power supply, the power supply impedance must be reduced. This can be done by connecting bypass capacitors of around 0.1 to 0.3 μF to pins V_1 to V_3 , as shown in figure 13.17, or by adding a split-resistance externally.

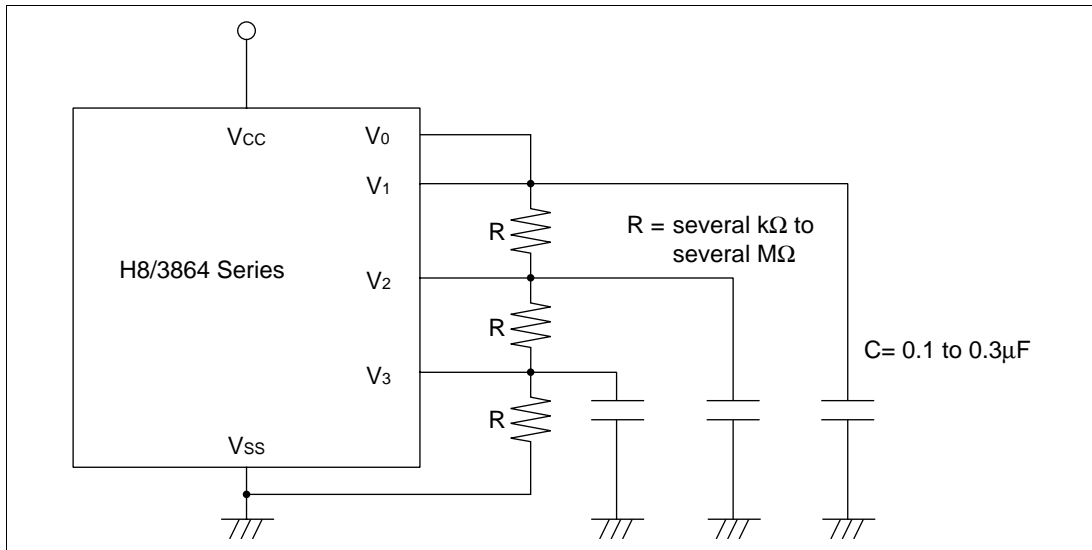

Figure 13.17 Connection of External Split-Resistance

13.3.8 Connection to HD66100

If the segments are to be expanded externally, an HD66100 should be connected. Connecting one HD66100 provides 80-segment expansion. When carrying out external expansion, select the external expansion signal function of pins SEG₃₂ to SEG₂₉ with the SGX bit in LPCR, and set bits SGS3 to SGS0 to 0000 or 0001. Data is output externally from SEG₁ of the LCD RAM. SEG₂₈ to SEG₁ function as ports.

Figure 13.18 shows examples of connection to an HD66100. The output level is determined by a combination of the data and the M pin output, but these combinations differ from those in the HD66100. Table 13.3 shows the output levels of the LCD drive power supply, and figures 13.15 and 13.16 show the common and segment waveforms for each duty cycle.

When ACT is cleared to 0, operation stops with CL₂ = 0, CL₁ = 0, M = 0, and DO at the data value (1 or 0) being output at that instant. In standby mode, the expansion pins go to the high-impedance (floating) state.

When external expansion is implemented, the load in the LCD panel increases and the on-chip power supply may not provide sufficient current capacity. In this case, measures should be taken as described in section 13.3.7, Boosting the LCD Drive Power Supply.

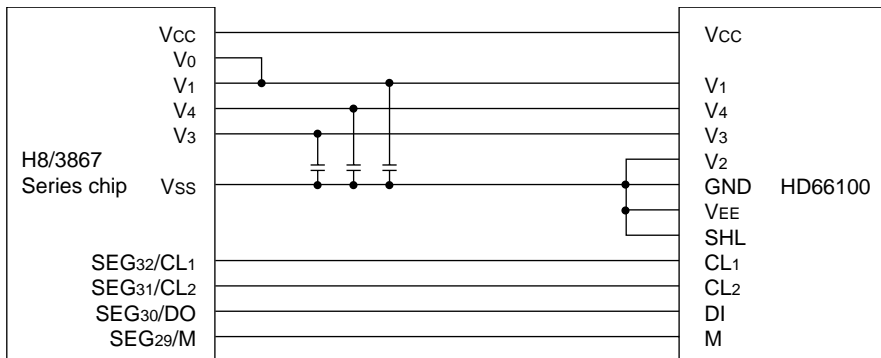

(a) 1/3 bias, 1/4 or 1/3 duty

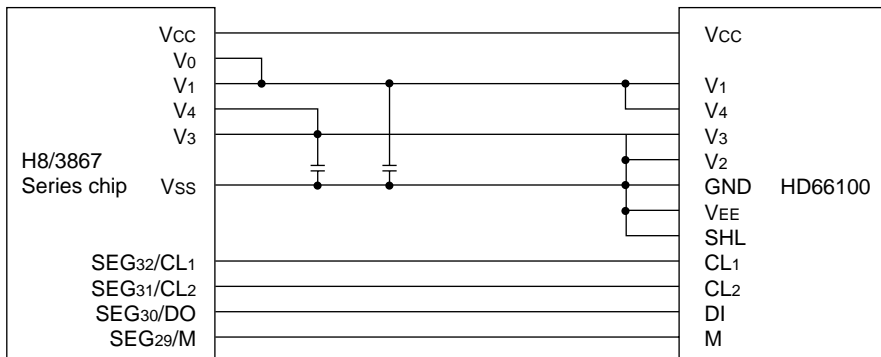

(b) 1/2 duty

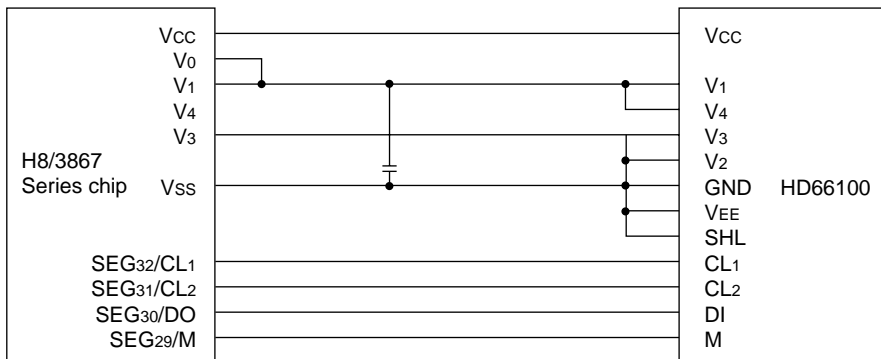

(c) Static mode

Figure 13.18 Connection to HD66100

Section 14 Power Supply Circuit

14.1 Overview

The H8/3867 Series incorporates an internal power supply step-down circuit. Use of this circuit enables the internal power supply to be fixed at a constant level of approximately 1.5 V, independently of the voltage of the power supply connected to the external V_{CC} pin. As a result, the current consumed when an external power supply is used at 1.8 V or above can be held down to virtually the same low level as when used at approximately 1.5 V. It is, of course, also possible to use the same level of external power supply voltage and internal power supply voltage without using the internal power supply step-down circuit.

14.2 When Using the Internal Power Supply Step-Down Circuit

Connect the external power supply to the V_{CC} pin, and connect a capacitance of approximately 0.1 μF between CV_{CC} and V_{SS} , as shown in figure 14.1. The internal step-down circuit is made effective simply by adding this external circuit.

- Notes:
1. In the external circuit interface, the external power supply voltage connected to V_{CC} and the GND potential connected to V_{SS} are the reference levels. For example, for port input/output levels, the V_{CC} level is the reference for the high level, and the V_{SS} level is that for the low level.
 2. When the internal power supply step-down circuit is used, operating frequency f_{osc} is 0.4 MHz to 2 MHz when $V_{CC} = 2.2 \text{ V}$ to 5.5 V, and 0.4 MHz to 1 MHz otherwise.
 3. The LCD power supply and A/D converter analog power supply are not affected by internal step-down processing.

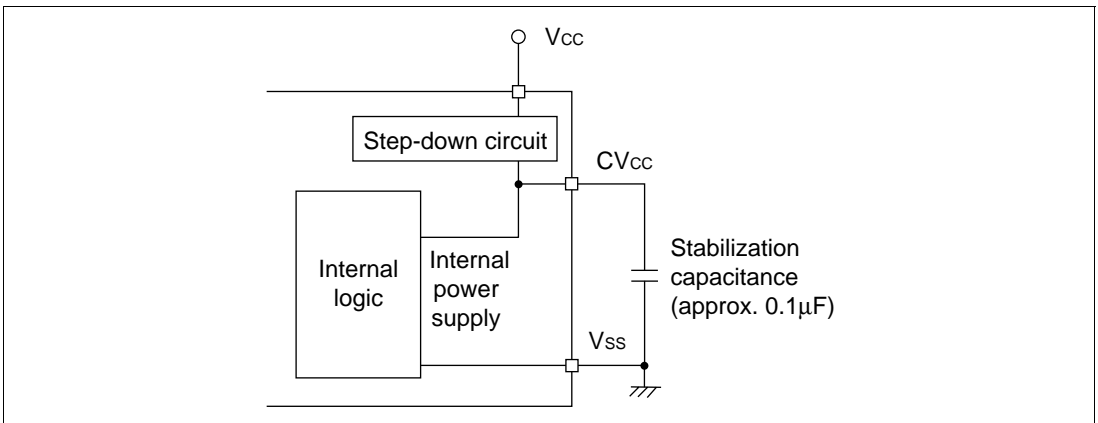

Figure 14.1 Power Supply Connection when Internal Step-Down Circuit Is Used

14.3 When Not Using the Internal Power Supply Step-Down Circuit

When the internal power supply step-down circuit is not used, connect the external power supply to the V_{CC} pin and CV_{CC} pin, as shown in figure 14.2. The external power supply is then input directly to the internal power supply.

Note: The permissible range for the power supply voltage is 1.8 V to 5.5 V. Operation cannot be guaranteed if a voltage outside this range (less than 1.8 V or more than 5.5 V) is input.

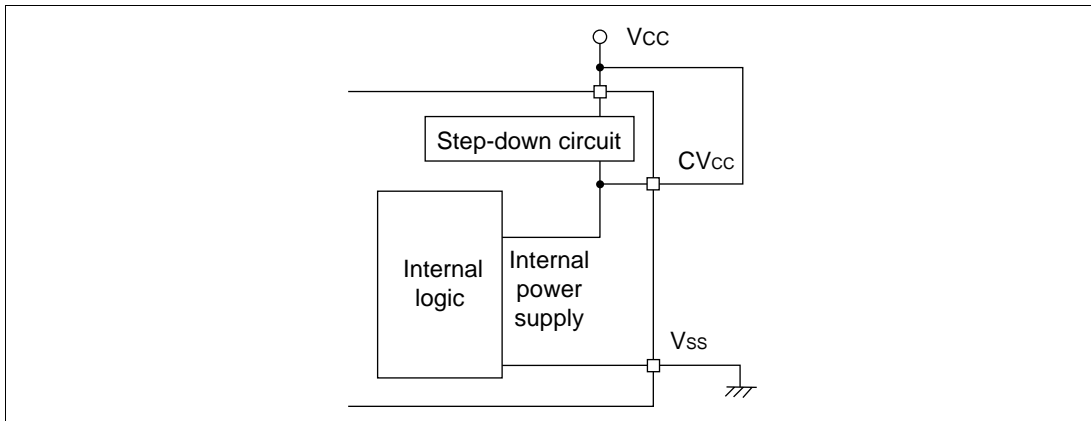

Figure 14.2 Power Supply Connection when Internal Step-Down Circuit Is Not Used

15.1 H8/3867 Series and H8/3827 Series Absolute Maximum Ratings

Table 15.1 lists the absolute maximum ratings.

Table 15.1 Absolute Maximum Ratings

| Item | | Symbol | Value | Unit |
|-----------------------------|-------------------------|-------------------|-------------------------|------|
| Power supply voltage | | V_{CC}, CV_{CC} | -0.3 to +7.0 | V |
| Analog power supply voltage | | AV_{CC} | -0.3 to +7.0 | V |
| Programming voltage | | V_{PP} | -0.3 to +13.0 | V |
| Input voltage | Ports other than Port B | V_{in} | -0.3 to $V_{CC} + 0.3$ | V |
| | Port B | AV_{in} | -0.3 to $AV_{CC} + 0.3$ | V |
| Operating temperature | | T_{opr} | -20 to +75 | °C |
| Storage temperature | | T_{stg} | -55 to +125 | °C |

Note: Permanent damage may occur to the chip if maximum ratings are exceeded. Normal operation should be under the conditions specified in Electrical Characteristics. Exceeding these values can result in incorrect operation and reduced reliability.

15.2 H8/3867 Series and H8/3827 Series Electrical Characteristics

15.2.1 Power Supply Voltage and Operating Range

The power supply voltage and operating range are indicated by the shaded region in the figures.

1. Power supply voltage and oscillator frequency range

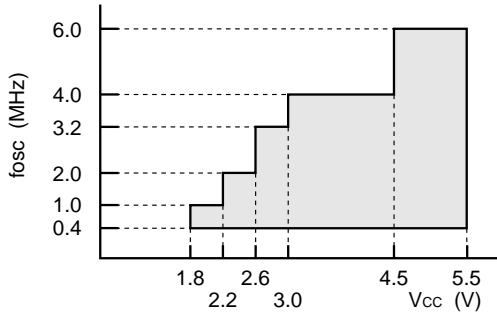

- Active (high-speed) mode
- Sleep (high-speed) mode
- Internal power supply step-down circuit not used

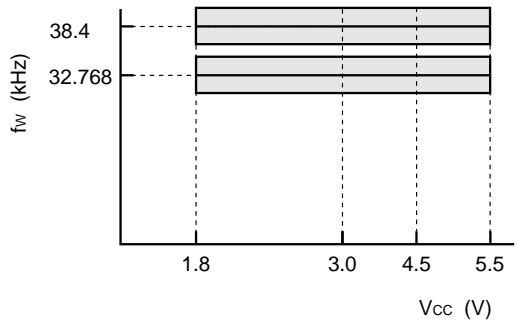

- All operating modes

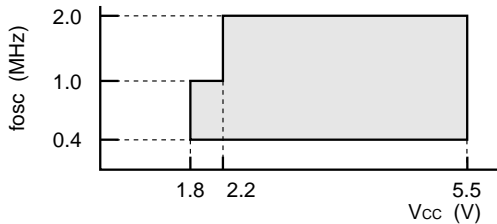

- Active (high-speed) mode
- Sleep (high-speed) mode
- Internal power supply step-down circuit used

2. Power supply voltage and operating frequency range

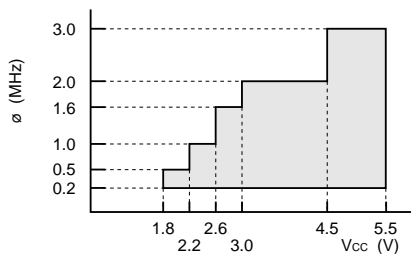

- Active (high-speed) mode
- Sleep (high-speed) mode (except CPU)
- Internal power supply step-down circuit not used

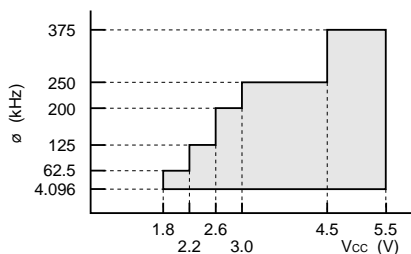

- Active (medium-speed) mode (except A/D converter and PWM)
- Sleep (medium-speed) mode (except A/D converter and PWM)
- Internal power supply step-down circuit not used

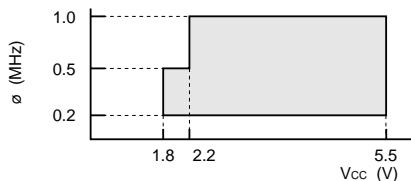

- Active (high-speed) mode
- Sleep (high-speed) mode (except CPU)
- Internal power supply step-down circuit used

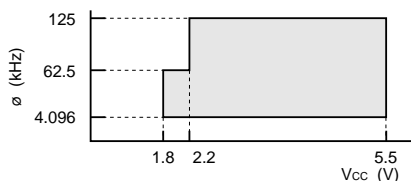

- Active (medium-speed) mode (except A/D converter and PWM)
- Sleep (medium-speed) mode (except A/D converter and PWM)
- Internal power supply step-down circuit used

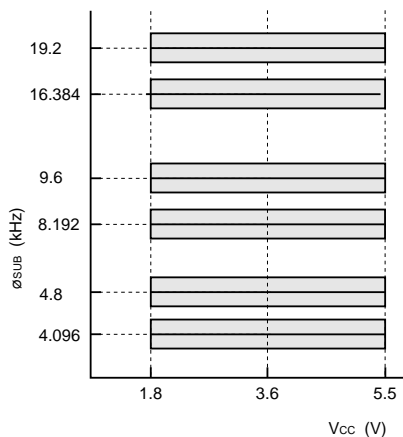

- Subactive mode
- Subsleep mode (except CPU)
- Watch mode (except CPU)

3. Analog power supply voltage and A/D converter operating range

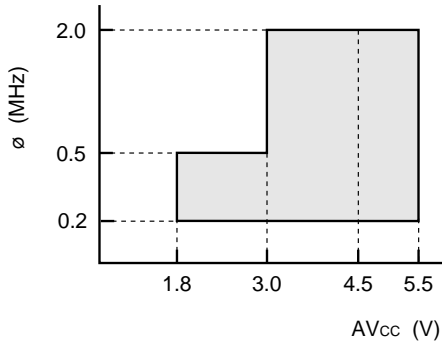

- Active (high-speed) mode
- Sleep (high-speed) mode
- Internal power supply step-down circuit not used

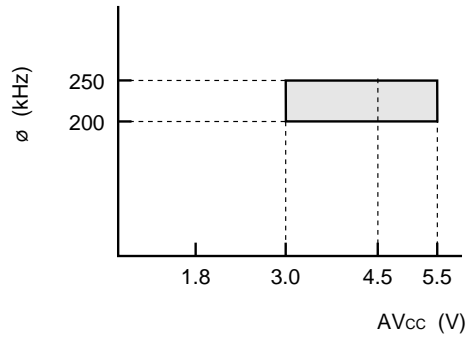

- Active (medium-speed) mode
- Sleep (medium-speed) mode
- Internal power supply step-down circuit not used

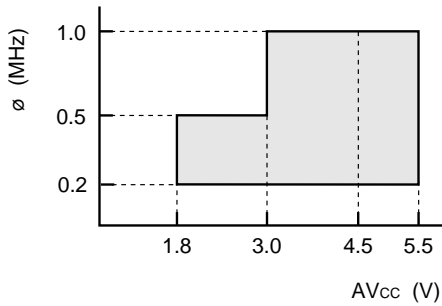

- Active (high-speed) mode
- Sleep (high-speed) mode
- Internal power supply step-down circuit used

15.2.2 DC Characteristics

Table 15.2 lists the DC characteristics of the H8/3864.

Table 15.2 DC Characteristics

$V_{CC} = 1.8\text{ V to }5.5\text{ V}$, $AV_{CC} = 1.8\text{ V to }5.5\text{ V}$, $V_{SS} = AV_{SS} = 0.0\text{ V}$, $T_a = -20^\circ\text{C to }+75^\circ\text{C}$
(including subactive mode) unless otherwise indicated.

| Item | Symbol | Applicable Pins | Values | | | Unit | Test Condition | Notes |
|--------------------|----------|--|-----------------|-----|------------------|------|---|-------|
| | | | Min | Typ | Max | | | |
| Input high voltage | V_{IH} | \overline{RES} , | $0.8 V_{CC}$ | — | $V_{CC} + 0.3$ | V | $V_{CC} = 4.0\text{ to }5.5\text{ V}$ | |
| | | \overline{WKP}_0 to \overline{WKP}_7 , \overline{IRQ}_0 to \overline{IRQ}_4 , AEVL, AEVH, TMIC, TMIF, TMIG SCK_{31} , SCK_{32} , ADTRG | $0.9 V_{CC}$ | — | $V_{CC} + 0.3$ | | Except the above | |
| | | RXD_{31} , RXD_{32} , | $0.7 V_{CC}$ | — | $V_{CC} + 0.3$ | V | $V_{CC} = 4.0\text{ to }5.5\text{ V}$ | |
| | | UD | $0.8 V_{CC}$ | — | $V_{CC} + 0.3$ | | Except the above | |
| | | OSC_1 | $0.8 V_{CC}$ | — | $V_{CC} + 0.3$ | V | $V_{CC} = 4.0\text{ to }5.5\text{ V}$ | |
| | | | $0.9 V_{CC}$ | — | $V_{CC} + 0.3$ | | Except the above | |
| | | X_1 | $0.9 V_{CC}$ | — | $V_{CC} + 0.3$ | V | $V_{CC} = 1.8\text{ V to }5.5\text{ V}$ | |
| | | $P1_0$ to $P1_7$, | $0.7 V_{CC}$ | — | $V_{CC} + 0.3$ | V | $V_{CC} = 4.0\text{ V to }5.5\text{ V}$ | |
| | | $P3_0$ to $P3_7$, $P4_0$ to $P4_3$, $P5_0$ to $P5_7$, $P6_0$ to $P6_7$, $P7_0$ to $P7_7$, $P8_0$ to $P8_7$, PA_0 to PA_3 | $0.8 V_{CC}$ | — | $V_{CC} + 0.3$ | | Except the above | |
| | | PB_0 to PB_7 | $0.7 V_{CC}$ | — | $AV_{CC} + 0.3$ | | $V_{CC} = 4.0\text{ V to }5.5\text{ V}$ | |
| $0.8 V_{CC}$ | — | | $AV_{CC} + 0.3$ | | Except the above | | | |

Note: Connect the TEST pin to V_{SS} .

Table 15.2 DC Characteristics (cont)

$V_{CC} = 1.8\text{ V to }5.5\text{ V}$, $AV_{CC} = 1.8\text{ V to }5.5\text{ V}$, $V_{SS} = AV_{SS} = 0.0\text{ V}$, $T_a = -20^\circ\text{C to }+75^\circ\text{C}$
(including subactive mode) unless otherwise indicated.

| Item | Symbol | Applicable Pins | Values | | | Unit | Test Condition | Notes |
|---------------------|----------|---|----------------|-----|--------------|------|--|-------|
| | | | Min | Typ | Max | | | |
| Input low voltage | V_{IL} | \overline{RES} , | -0.3 | — | $0.2 V_{CC}$ | V | $V_{CC} = 4.0\text{ to }5.5\text{ V}$ | |
| | | \overline{WKP}_0 to \overline{WKP}_7 , \overline{IRQ}_0 to \overline{IRQ}_4 , AEVL, AEVH, TMIC, TMIF, TMIG SCK_{31} , SCK_{32} , \overline{ADTRG} | -0.3 | — | $0.1 V_{CC}$ | | Except the above | |
| | | RXD_{31} , RXD_{32} , | -0.3 | — | $0.3 V_{CC}$ | V | $V_{CC} = 4.0\text{ to }5.5\text{ V}$ | |
| | | UD | -0.3 | — | $0.2 V_{CC}$ | | Except the above | |
| | | OSC_1 | -0.3 | — | 0.2 | | When internal step-down circuit is used. | |
| | | | -0.3 | — | $0.2 V_{CC}$ | V | $V_{CC} = 4.0\text{ to }5.5\text{ V}$ | |
| | | | -0.3 | — | $0.1 V_{CC}$ | | Except the above | |
| | | X_1 | -0.3 | — | $0.1 V_{CC}$ | V | $V_{CC} = 1.8\text{ V to }5.5\text{ V}$ | |
| | | $P1_0$ to $P1_7$, | -0.3 | — | $0.3 V_{CC}$ | V | $V_{CC} = 4.0\text{ V to }5.5\text{ V}$ | |
| | | $P3_0$ to $P3_7$, $P4_0$ to $P4_3$, $P5_0$ to $P5_7$, $P6_0$ to $P6_7$, $P7_0$ to $P7_7$, $P8_0$ to $P8_7$, PA_0 to PA_3 , PB_0 to PB_7 | -0.3 | — | $0.2 V_{CC}$ | | Except the above | |
| Output high voltage | V_{OH} | $P1_0$ to $P1_7$, $P3_0$ to $P3_7$, | $V_{CC} - 1.0$ | — | — | V | $V_{CC} = 4.0\text{ V to }5.5\text{ V}$ $-I_{OH} = 1.0\text{ mA}$ | |
| | | $P4_0$ to $P4_2$, $P5_0$ to $P5_7$, | $V_{CC} - 0.5$ | — | — | | $V_{CC} = 4.0\text{ V to }5.5\text{ V}$ $-I_{OH} = 0.5\text{ mA}$ | |
| | | $P6_0$ to $P6_7$, $P7_0$ to $P7_7$, $P8_0$ to $P8_7$, PA_0 to PA_3 | $V_{CC} - 0.3$ | — | — | | $-I_{OH} = 0.1\text{ mA}$ | |
| | | | | | | | | |

Table 15.2 DC Characteristics (cont)

$V_{CC} = 1.8\text{ V to }5.5\text{ V}$, $AV_{CC} = 1.8\text{ V to }5.5\text{ V}$, $V_{SS} = AV_{SS} = 0.0\text{ V}$, $T_a = -20^\circ\text{C to }+75^\circ\text{C}$
(including subactive mode) unless otherwise indicated.

| Item | Symbol | Applicable Pins | Values | | | Unit | Test Condition | Notes |
|------------------------------|------------|---|------------------------------------|------|-------|--------------------------|---|-----------------|
| | | | Min | Typ | Max | | | |
| Output low voltage | V_{OL} | P1 ₀ to P1 ₇ , P4 ₀ to P4 ₂ | — | — | 0.6 | V | $V_{CC} = 4.0\text{ V to }5.5\text{ V}$ $I_{OL} = 1.6\text{ mA}$ | |
| | | | — | — | 0.5 | | $I_{OL} = 0.4\text{ mA}$ | |
| | | P5 ₀ to P5 ₇ , P6 ₀ to P6 ₇ , P7 ₀ to P7 ₇ , P8 ₀ to P8 ₇ , PA ₀ to PA ₃ | — | — | 0.5 | $I_{OL} = 0.4\text{ mA}$ | | |
| | | | P3 ₀ to P3 ₇ | — | — | 1.5 | $V_{CC} = 4.0\text{ V to }5.5\text{ V}$ $I_{OL} = 10\text{ mA}$ | |
| | | | | — | — | 0.6 | $V_{CC} = 4.0\text{ V to }5.5\text{ V}$ $I_{OL} = 1.6\text{ mA}$ | |
| — | — | 0.5 | $I_{OL} = 0.4\text{ mA}$ | | | | | |
| Input/output leakage current | $ I_{IL} $ | \overline{RES} , P4 ₃ | — | — | 20.0 | μA | $V_{IN} = 0.5\text{ V to }V_{CC} - 0.5\text{ V}$ | *2 |
| | | | — | — | 1.0 | | $V_{CC} - 0.5\text{ V}$ | *1 |
| | | OSC ₁ , X ₁ , P1 ₀ to P1 ₇ , P3 ₀ to P3 ₇ , P4 ₀ to P4 ₂ , P5 ₀ to P5 ₇ , P6 ₀ to P6 ₇ , P7 ₀ to P7 ₇ , P8 ₀ to P8 ₇ , PA ₀ to PA ₃ | — | — | 1.0 | μA | $V_{IN} = 0.5\text{ V to }V_{CC} - 0.5\text{ V}$ | |
| | | PB ₀ to PB ₇ | — | — | 1.0 | μA | $V_{IN} = 0.5\text{ V to }AV_{CC} - 0.5\text{ V}$ | |
| Pull-up MOS current | $-I_p$ | P1 ₀ to P1 ₇ , P3 ₀ to P3 ₇ , | 50.0 | — | 300.0 | μA | $V_{CC} = 5\text{ V}$, $V_{IN} = 0\text{ V}$ | Reference value |
| | | P5 ₀ to P5 ₇ , P6 ₀ to P6 ₇ | — | 35.0 | — | | $V_{CC} = 2.7\text{ V}$, $V_{IN} = 0\text{ V}$ | |

Table 15.2 DC Characteristics (cont)

$V_{CC} = 1.8\text{ V to }5.5\text{ V}$, $AV_{CC} = 1.8\text{ V to }5.5\text{ V}$, $V_{SS} = AV_{SS} = 0.0\text{ V}$, $T_a = -20^\circ\text{C to }+75^\circ\text{C}$
(including subactive mode) unless otherwise indicated.

| Item | Symbol | Applicable Pins | Values | | | Unit | Test Condition | Notes |
|------------------------------------|-------------|---|--------|-----|------|---------------|---|-----------------------------------|
| | | | Min | Typ | Max | | | |
| Input capacitance | C_{IN} | All input pins except power supply, RES, P4 ₃ , PB ₀ to PB ₇ | — | — | 15.0 | pF | $f = 1\text{ MHz}$, $V_{IN} = 0\text{ V}$, $T_a = 25^\circ\text{C}$ | |
| | | | — | — | 80.0 | | | *2 |
| | | | — | — | 15.0 | | | *1 |
| | | | — | — | 50.0 | | | *2 |
| | | | — | — | 15.0 | | | *1 |
| Active mode current | I_{OPE1} | V_{CC} | — | 0.7 | 1.0 | mA | Active (high-speed) mode $V_{CC} = 5\text{ V}$, $f_{OSC} = 2\text{ MHz}$ | *3 *4 *5 |
| dissipation | I_{OPE2} | V_{CC} | — | 0.3 | 0.5 | mA | Active (medium-speed) mode $V_{CC} = 5\text{ V}$, $f_{OSC} = 2\text{ MHz}$ Divided by 128 | *3 *4 *5 |
| Sleep mode current dissipation | I_{SLEEP} | V_{CC} | — | 0.4 | 0.6 | mA | $V_{CC} = 5\text{ V}$, $f_{OSC} = 2\text{ MHz}$ | *3 *4 *5 |
| Subactive mode current dissipation | I_{SUB} | V_{CC} | — | 15 | 30 | μA | $V_{CC} = 2.7\text{ V}$, LCD on 32-kHz crystal oscillator ($\phi_{SUB} = \phi_w/2$) | *3 *4 *5 |
| | | | — | 8 | — | μA | $V_{CC} = 2.7\text{ V}$, LCD on 32-kHz crystal oscillator ($\phi_{SUB} = \phi_w/8$) | *3 *4 Reference value *5 |
| Subsleep mode current dissipation | I_{SUBSP} | V_{CC} | — | 7.5 | 16 | μA | $V_{CC} = 2.7\text{ V}$, LCD on 32-kHz crystal oscillator ($\phi_{SUB} = \phi_w/2$) | *3 *4 *5 |

Table 15.2 DC Characteristics (cont)

$V_{CC} = 1.8\text{ V to }5.5\text{ V}$, $AV_{CC} = 1.8\text{ V to }5.5\text{ V}$, $V_{SS} = AV_{SS} = 0.0\text{ V}$, $T_a = -20^\circ\text{C to }+75^\circ\text{C}$
(including subactive mode) unless otherwise indicated.

| Item | Symbol | Applicable Pins | Values | | | Unit | Test Condition | Notes |
|----------------------------------|-------------|-----------------|--------|-----|-----|---------------|---|----------------|
| | | | Min | Typ | Max | | | |
| Watch mode current dissipation | I_{WATCH} | V_{CC} | — | 2.8 | 6 | μA | $V_{CC} = 2.7\text{ V}$ 3 2-kHz crystal oscillator LCD not used | *3 *4 *5 |
| Standby mode current dissipation | I_{STBY} | V_{CC} | — | 1.0 | 5.0 | μA | 32-kHz crystal oscillator not used | *3 *4 |
| RAM data retaining voltage | V_{RAM} | V_{CC} | 1.5 | — | — | V | | *3 *4 |

- Notes: 1. Applies to the Mask ROM products.
2. Applies to the HD6473867 and HD6473827.
3. Pin states during current measurement.

| Mode | \overline{RES} Pin | Internal State | Other Pins | LCD Power Supply | Oscillator Pins |
|---|----------------------|------------------------------------|------------|------------------|--|
| Active (high-speed) mode (I_{OPE1}) | V_{CC} | Operates | V_{CC} | Halted | System clock oscillator: crystal |
| Active (medium-speed) mode (I_{OPE2}) | | | | | Subclock oscillator: Pin $X_1 = \text{GND}$ |
| Sleep mode | V_{CC} | Only timers operate | V_{CC} | Halted | |
| Subactive mode | V_{CC} | Operates | V_{CC} | Halted | System clock oscillator: |
| Subsleep mode | V_{CC} | Only timers operate, CPU stops | V_{CC} | Halted | crystal Subclock oscillator: |
| Watch mode | V_{CC} | Only time base operates, CPU stops | V_{CC} | Halted | crystal |
| Standby mode | V_{CC} | CPU and timers both stop | V_{CC} | Halted | System clock oscillator: crystal Subclock oscillator: Pin $X_1 = \text{GND}$ |

4. Excludes current in pull-up MOS transistors and output buffers.
5. When internal step-down circuit is used.

Table 15.2 DC Characteristics (cont)

$V_{CC} = 1.8 \text{ V to } 5.5 \text{ V}$, $AV_{CC} = 1.8 \text{ V to } 5.5 \text{ V}$, $V_{SS} = AV_{SS} = 0.0 \text{ V}$, $T_a = -20^\circ\text{C to } +75^\circ\text{C}$
(including subactive mode) unless otherwise indicated.

| Item | Symbol | Applicable Pins | Values | | | Unit | Test Condition | Notes |
|---|-----------|---------------------------|--------|-----|------|------|--|-------|
| | | | Min | Typ | Max | | | |
| Allowable output low current (per pin) | I_{OL} | Output pins except port 3 | — | — | 2.0 | mA | $V_{CC} = 4.0 \text{ V to } 5.5 \text{ V}$ | |
| | | Port 3 | — | — | 10.0 | | $V_{CC} = 4.0 \text{ V to } 5.5 \text{ V}$ | |
| | | All output pins | — | — | 0.5 | | | |
| Allowable output low current (total) | I_{OL} | Output pins except port 3 | — | — | 40.0 | mA | $V_{CC} = 4.0 \text{ V to } 5.5 \text{ V}$ | |
| | | Port 3 | — | — | 80.0 | | $V_{CC} = 4.0 \text{ V to } 5.5 \text{ V}$ | |
| | | All output pins | — | — | 20.0 | | | |
| Allowable output high current (per pin) | $-I_{OH}$ | All output pins | — | — | 2.0 | mA | $V_{CC} = 4.0 \text{ V to } 5.5 \text{ V}$ | |
| | | | — | — | 0.2 | | Except the above | |
| Allowable output high | $-I_{OH}$ | All output pins | — | — | 15.0 | mA | $V_{CC} = 4.0 \text{ V to } 5.5 \text{ V}$ | |
| | | | — | — | 10.0 | | Except the above | |

15.2.3 AC Characteristics

Table 15.3 lists the control signal timing, and tables 15.4 lists the serial interface timing of the H8/3864.

Table 15.3 Control Signal Timing

$V_{CC} = 1.8\text{ V to }5.5\text{ V}$, $AV_{CC} = 1.8\text{ V to }5.5\text{ V}$, $V_{SS} = AV_{SS} = 0.0\text{ V}$, $T_a = -20^\circ\text{C to }+75^\circ\text{C}$ (including subactive mode) unless otherwise indicated.

| Item | Symbol | Applicable Pins | Values | | | Unit | Test Condition | Reference |
|--|--------------|-------------------------------------|--------|----------------|-------|---------------------------|---|-------------|
| | | | Min | Typ | Max | | | Figure |
| System clock oscillation frequency | f_{OSC} | OSC ₁ , OSC ₂ | 0.4 | — | 6 | MHz | $V_{CC} = 4.5\text{ V to }5.5\text{ V}$ *2 | |
| | | | 0.4 | — | 4 | | | |
| | | | 0.4 | — | 3.2 | | | |
| | | | 0.4 | — | 2 | | | |
| | | | 0.4 | — | 1 | | | |
| OSC clock (\emptyset_{OSC}) cycle time | t_{OSC} | OSC ₁ , OSC ₂ | 167 | — | 2500 | ns | $V_{CC} = 4.5\text{ V to }5.5\text{ V}$ | Figure 15.1 |
| | | | 250 | — | 2500 | | | |
| | | | 313 | — | 2500 | | | |
| | | | 500 | — | 2500 | | | |
| | | | 1000 | — | 2500 | | | |
| System clock (\emptyset) cycle time | t_{cyc} | | 2 | — | 128 | t_{OSC} | | |
| | | | — | — | 244.1 | | | |
| Subclock oscillation frequency | f_W | X ₁ , X ₂ | — | 32.768 or 38.4 | — | kHz | | |
| Watch clock (\emptyset_W) cycle time | t_W | X ₁ , X ₂ | — | 30.5 or 26.0 | — | μs | Figure 15.1 | |
| Subclock (\emptyset_{SUB}) cycle time | t_{subcyc} | | 2 | — | 8 | t_W | *1 | |
| Instruction cycle time | | | 2 | — | — | t_{cyc} t_{subcyc} | | |
| Oscillation stabilization time | t_{rc} | OSC ₁ , OSC ₂ | — | 20 | 45 | μs | Figure 15.9 $V_{CC} = 2.2\text{ V to }5.5\text{ V}$ *2 | Figure 15.9 |
| | | | — | 0.1 | 8 | | | |
| | | | — | — | 50 | | | |
| | | | | | | ms | Figure 15.9 $V_{CC} = 2.2\text{ V to }5.5\text{ V}$ | |
| | | | | | | ms | Except the above | |

Table 15.3 Control Signal Timing (cont)

$V_{CC} = 1.8\text{ V to }5.5\text{ V}$, $AV_{CC} = 1.8\text{ V to }5.5\text{ V}$, $V_{SS} = AV_{SS} = 0.0\text{ V}$, $T_a = -20^\circ\text{C to }+75^\circ\text{C}$
(including subactive mode) unless otherwise indicated.

| Item | Symbol | Applicable Pins | Values | | | Unit | Test Condition | Reference Figure | |
|---------------------------------------|-----------|-------------------------|--------|----------------------|-----|---------------|--|---------------------|-------------|
| | | | Min | Typ | Max | | | | |
| Oscillation stabilization time | t_{rc} | X_1, X_2 | — | — | 2.0 | s | | | |
| External clock high width | t_{CPH} | OSC_1 | 70 | — | — | ns | $V_{CC} = 4.5\text{ V to }5.5\text{ V}$ | Figure 15.1 | |
| | | | 100 | — | — | | $V_{CC} = 3.0\text{ V to }5.5\text{ V}^{*2}$ | | |
| | | | 140 | — | — | | $V_{CC} = 2.6\text{ V to }5.5\text{ V}$ | | |
| | | | 200 | — | — | | $V_{CC} = 2.2\text{ V to }5.5\text{ V}$ | | Figure 15.1 |
| | | | 400 | — | — | | Except the above | | |
| | | X_1 | — | 15.26 or 13.02 | — | μs | | | |
| External clock low width | t_{CPL} | OSC_1 | 70 | — | — | ns | $V_{CC} = 4.5\text{ V to }5.5\text{ V}$ | Figure 15.1 | |
| | | | 100 | — | — | | $V_{CC} = 3.0\text{ V to }5.5\text{ V}^{*2}$ | | |
| | | | 140 | — | — | | $V_{CC} = 2.6\text{ V to }5.5\text{ V}$ | | |
| | | | 200 | — | — | | $V_{CC} = 2.2\text{ V to }5.5\text{ V}$ | | Figure 15.1 |
| | | | 400 | — | — | | Except the above | | |
| | | X_1 | — | 15.26 or 13.02 | — | μs | | | |
| External clock rise time | t_{CPr} | OSC_1 | — | — | 20 | ns | $V_{CC} = 4.5\text{ V to }5.5\text{ V}$ | Figure 15.1 | |
| | | | — | — | 30 | | $V_{CC} = 2.6\text{ V to }5.5\text{ V}^{*2}$ | | |
| | | | — | — | 55 | | Except the above | | Figure 15.1 |
| | | | X_1 | — | — | | 55.0 | | ns |
| External clock fall time | t_{CPf} | OSC_1 | — | — | 20 | ns | $V_{CC} = 4.5\text{ V to }5.5\text{ V}$ | Figure 15.1 | |
| | | | — | — | 30 | | $V_{CC} = 2.6\text{ V to }5.5\text{ V}^{*2}$ | | |
| | | | — | — | 55 | | Except the above | | Figure 15.1 |
| | | | X_1 | — | — | | 55.0 | | ns |
| Pin $\overline{\text{RES}}$ low width | t_{REL} | $\overline{\text{RES}}$ | 10 | — | — | t_{cyc} | | Figure 15.2 | |

Table 15.3 Control Signal Timing (cont)

$V_{CC} = 1.8\text{ V to }5.5\text{ V}$, $AV_{CC} = 1.8\text{ V to }5.5\text{ V}$, $V_{SS} = AV_{SS} = 0.0\text{ V}$, $T_a = -20^\circ\text{C to }+75^\circ\text{C}$
(including subactive mode) unless otherwise indicated.

| Item | Symbol | Applicable Pins | Values | | | Unit | Test Condition | Reference |
|---------------------------------|------------------------|---|--------|-----|-----|---------------------------|----------------|-------------|
| | | | Min | Typ | Max | | | Figure |
| Input pin high width | t_{IH} | \overline{IRQ}_0 to \overline{IRQ}_4 , \overline{WKP}_0 to \overline{WKP}_7 , \overline{ADTRG} , TMIC, TMIF, TMIG, AEVL, AEVH | 2 | — | — | t_{cyc} t_{subcyc} | | Figure 15.3 |
| Input pin low width | t_{IL} | \overline{IRQ}_0 to \overline{IRQ}_4 , \overline{WKP}_0 to \overline{WKP}_7 , \overline{ADTRG} , TMIC, TMIF, TMIG, AEVL, AEVH | 2 | — | — | t_{cyc} t_{subcyc} | | Figure 15.3 |
| UD pin minimum modulation width | t_{UDH} t_{UDL} | UD | 4 | — | — | t_{cyc} t_{subcyc} | | Figure 15.4 |

Notes: 1. Selected with SA1 and SA0 of system clock control register 2 (SYSCR2).
2. Internal power supply step-down circuit not used

Table 15.4 Serial Interface (SCI3-1, SCI3-2) Timing

$V_{CC} = 1.8\text{ V to }5.5\text{ V}$, $AV_{CC} = 1.8\text{ V to }5.5\text{ V}$, $V_{SS} = AV_{SS} = 0.0\text{ V}$, $T_a = -20^\circ\text{C to }+75^\circ\text{C}$
(including subactive mode) unless otherwise indicated.

| Item | Symbol | Values | | | Unit | Test Conditions | Reference | |
|--|--------------|------------|-------|-----|------------|-----------------|---|------------------|
| | | Min | Typ | Max | | | Figure | |
| Input clock cycle | Asynchronous | t_{scyc} | 4 | — | — | t_{cyc} or | Figure 15.5 | |
| | Synchronous | | 6 | — | — | t_{subcyc} | | |
| Input clock pulse width | t_{SCKW} | 0.4 | — | 0.6 | t_{scyc} | | Figure 15.5 | |
| Transmit data delay time (synchronous) | t_{TXD} | | — | — | 1 | t_{cyc} or | $V_{CC} = 4.0\text{ V to }5.5\text{ V}$ | Figure 15.6 |
| | | | — | — | 1 | t_{subcyc} | Except the above | |
| Receive data setup time (synchronous) | t_{RXS} | | 200.0 | — | — | ns | $V_{CC} = 4.0\text{ V to }5.5\text{ V}$ | Figure 15.6 *1 |
| | | | 400.0 | — | — | | | Except the above |
| Receive data hold time (synchronous) | t_{RXH} | | 200.0 | — | — | ns | $V_{CC} = 4.0\text{ V to }5.5\text{ V}$ | Figure 15.6 *1 |
| | | | 400.0 | — | — | | | Except the above |

Note: 1. When internal step-down circuit is not used.

15.2.4 A/D Converter Characteristics

Table 15.5 shows the A/D converter characteristics of the H8/3864.

Table 15.5 A/D Converter Characteristics

$V_{CC} = 1.8 \text{ V to } 5.5 \text{ V}$, $V_{SS} = AV_{SS} = 0.0 \text{ V}$, $T_a = -20^\circ\text{C to } +75^\circ\text{C}$ (including subactive mode) unless otherwise indicated.

| Item | Symbol | Applicable Pins | Values | | | Unit | Test Condition | Reference |
|-----------------------------------|--------------|------------------|--------|-----|-----------------|---------------|---|-----------------------|
| | | | Min | Typ | Max | | | Figure |
| Analog power supply voltage | AV_{CC} | AV_{CC} | 1.8 | — | 5.5 | V | | *1 |
| Analog input voltage | AV_{IN} | AN_0 to AN_7 | -0.3 | — | $AV_{CC} + 0.3$ | V | | |
| Analog power supply current | AI_{OPE} | AV_{CC} | — | — | 1.5 | mA | $AV_{CC} = 5 \text{ V}$ | |
| | AI_{STOP1} | AV_{CC} | — | 600 | — | μA | | *2 Reference value |
| | AI_{STOP2} | AV_{CC} | — | — | 5 | μA | | *3 |
| Analog input capacitance | C_{AIN} | AN_0 to AN_7 | — | — | 15.0 | pF | | |
| Allowable signal source impedance | R_{AIN} | | — | — | 10.0 | k | | |
| Resolution (data length) | | | — | — | 10 | bit | | |
| Nonlinearity error | | | — | — | ± 2.5 | LSB | $AV_{CC} = 3.0 \text{ V to } 5.5 \text{ V}$ $V_{CC} = 3.0 \text{ V to } 5.5 \text{ V}$ | *4 |
| | | | — | — | ± 5.5 | | $AV_{CC} = 2.0 \text{ V to } 5.5 \text{ V}$ $V_{CC} = 2.0 \text{ V to } 5.5 \text{ V}$ | |
| | | | — | — | ± 7.5 | | Except the above | *5 |
| Quantization error | | | — | — | ± 0.5 | LSB | | |

Table 15.5 A/D Converter Characteristics (cont)

$V_{CC} = 1.8\text{ V to }5.5\text{ V}$, $V_{SS} = AV_{SS} = 0.0\text{ V}$, $T_a = -20^{\circ}\text{C to }+75^{\circ}\text{C}$ (including subactive mode) unless otherwise indicated.

| Item | Symbol | Applicable Pins | Values | | | Unit | Test Condition | Reference Figure |
|-------------------|--------|-----------------|--------|-----|-----------|---------------|---|------------------|
| | | | Min | Typ | Max | | | |
| Absolute accuracy | | | — | — | ± 3.0 | LSB | $AV_{CC} = 3.0\text{ V to }5.5\text{ V}$ $V_{CC} = 3.0\text{ V to }5.5\text{ V}$ | *4 |
| | | | — | — | ± 6.0 | | $AV_{CC} = 2.0\text{ V to }5.5\text{ V}$ $V_{CC} = 2.0\text{ V to }5.5\text{ V}$ | |
| | | | — | — | ± 8.0 | | Except the above | |
| Conversion time | | | 15.5 | — | 155 | μs | $AV_{CC} = 3.0\text{ V to }5.5\text{ V}$ $V_{CC} = 3.0\text{ V to }5.5\text{ V}$ | *4 |
| | | | 62 | — | 155 | | Except the above | |

- Notes:
1. Set $AV_{CC} = V_{CC}$ when the A/D converter is not used.
 2. AI_{STOP1} is the current in active and sleep modes while the A/D converter is idle.
 3. AI_{STOP2} is the current at reset and in standby, watch, subactive, and subsleep modes while the A/D converter is idle.
 4. When internal step-down circuit is not used.
 5. Conversion time 124 μs

15.2.5 LCD Characteristics

Table 15.6 shows the LCD characteristics.

Table 15.6 LCD Characteristics

$V_{CC} = 1.8 \text{ V to } 5.5 \text{ V}$, $AV_{CC} = 1.8 \text{ V to } 5.5 \text{ V}$, $V_{SS} = AV_{SS} = 0.0 \text{ V}$, $T_a = -20^\circ\text{C to } +75^\circ\text{C}$
(including subactive mode) unless otherwise specified.

| Item | Symbol | Applicable Pins | Test Conditions | Values | | | Unit | Reference Figure |
|---|-----------|---------------------------------------|--|--------|-----|-----|------|-----------------------|
| | | | | Min | Typ | Max | | |
| Segment driver drop voltage | V_{DS} | SEG ₁ to SEG ₃₂ | $I_D = 2 \mu\text{A}$ $V_1 = 2.7 \text{ to } 5.5 \text{ V}$ | — | — | 0.6 | V | *1 |
| Common driver drop voltage | V_{DC} | COM ₁ to COM ₄ | $I_D = 2 \mu\text{A}$ $V_1 = 2.7 \text{ to } 5.5 \text{ V}$ | — | — | 0.3 | V | *1 |
| LCD power supply split-resistance | R_{LCD} | | Between V_1 and V_{SS} | 0.5 | 3.0 | 9.0 | M | |
| On-chip liquid crystal display power supply voltage | V_{LP} | V_0 | | — | 5.0 | — | V | *2 Reference value |
| Liquid crystal display voltage | V_{LCD} | V_1 | | 2.2 | — | 5.5 | V | *3 |

- Notes: 1. The voltage drop from power supply pins V_1 , V_2 , V_3 , and V_{SS} to each segment pin or common pin.
 2. The output voltage in step-up constant-voltage power supply operation (unloaded).
 3. When the liquid crystal display voltage is supplied from an external power source, ensure that the following relationship is maintained: $V_1 \geq V_2 \geq V_3 \geq V_{SS}$.

Table 15.7 AC Characteristics for External Segment Expansion

$V_{CC} = 1.8 \text{ V to } 5.5 \text{ V}$, $V_{SS} = 0.0 \text{ V}$, $T_a = -20^\circ\text{C to } +75^\circ\text{C}$ (including subactive mode) unless otherwise specified.

| Item | Symbol | Applicable Pins | Test Conditions | Values | | | Unit | Reference |
|---------------------------|-----------|-----------------------------------|-----------------|--------|-----|------|------|-------------|
| | | | | Min | Typ | Max | | |
| Clock high width | t_{CWH} | CL ₁ , CL ₂ | *1 | 800 | — | — | ns | Figure 15.9 |
| Clock low width | t_{CWL} | CL ₂ | *1 | 800 | — | — | ns | Figure 15.9 |
| Clock setup time | t_{CSU} | CL ₁ , CL ₂ | *1 | 500 | — | — | ns | Figure 15.9 |
| Data setup time | t_{SU} | DO | *1 | 300 | — | — | ns | Figure 15.9 |
| Data hold time | t_{DH} | DO | *1 | 300 | — | — | ns | Figure 15.9 |
| M delay time | t_{DM} | M | | -1000 | — | 1000 | ns | Figure 15.9 |
| Clock rise and fall times | t_{CT} | CL ₁ , CL ₂ | | — | — | 170 | ns | Figure 15.9 |

Note: 1. Value when the frame frequency is set to between 30.5 Hz and 488 Hz.

15.3 Operation Timing

Figures 15.1 to 15.6 show timing diagrams.

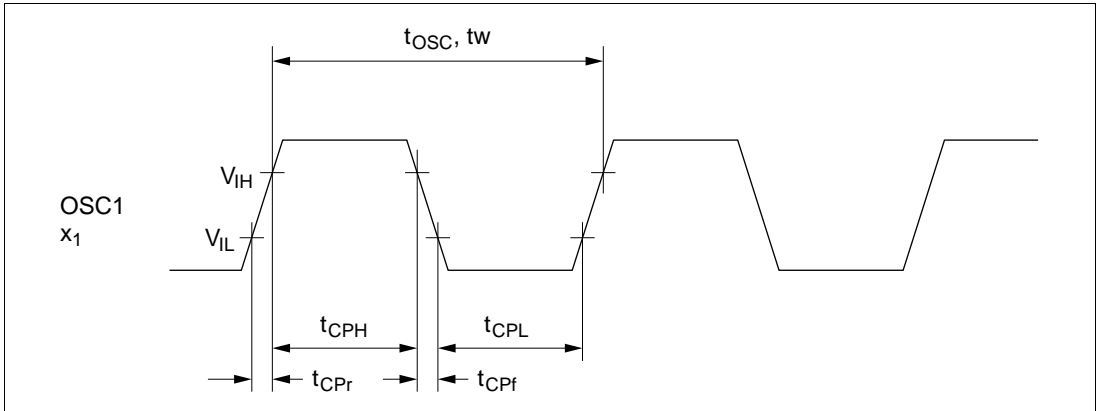

Figure 15.1 Clock Input Timing

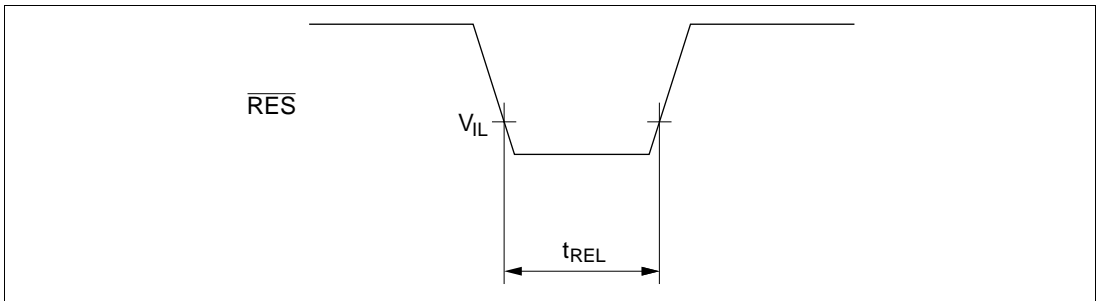

Figure 15.2 RES Low Width

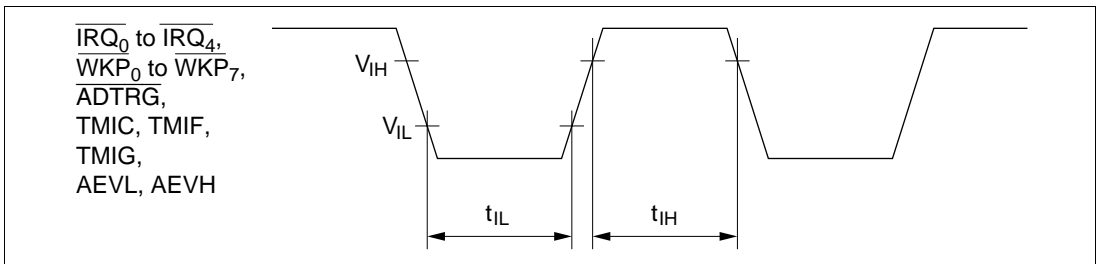

Figure 15.3 Input Timing

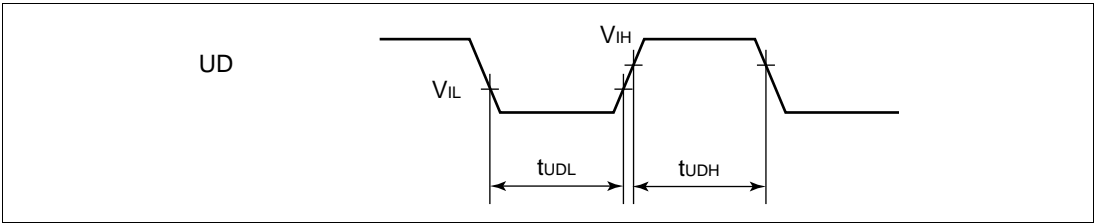

Figure 15.4 UD Pin Minimum Modulation Width Timing

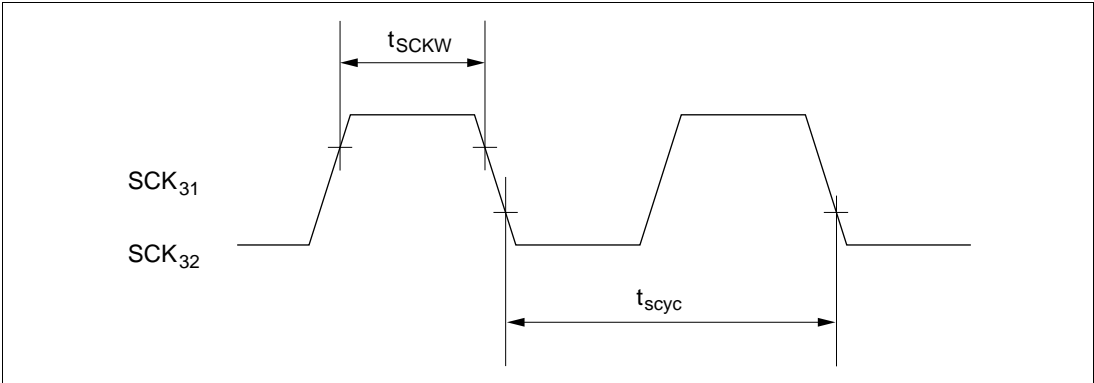
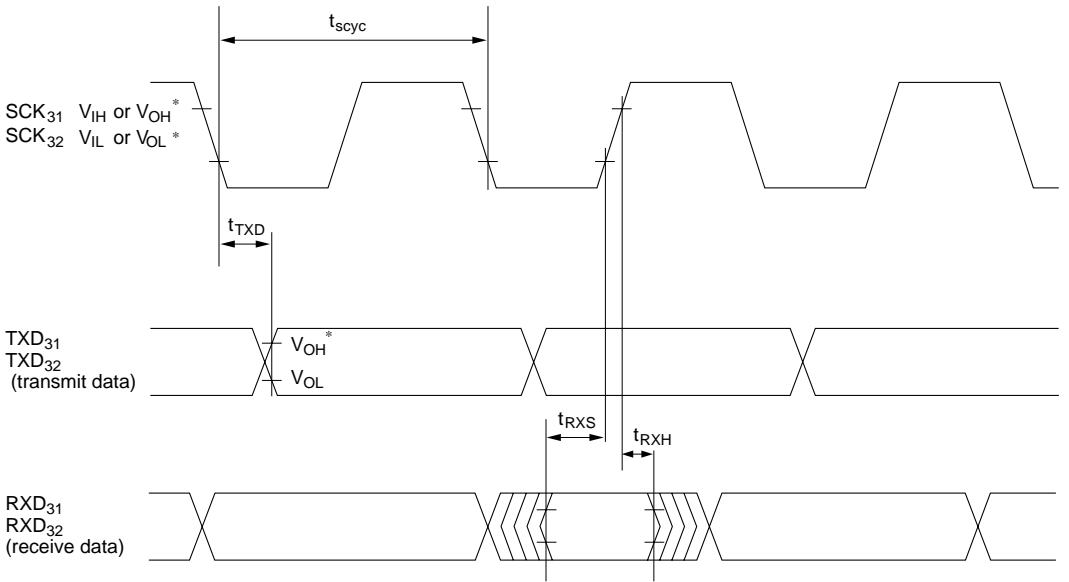

Figure 15.5 SCK3 Input Clock Timing



Note: * Output timing reference levels

| | |
|-------------|------------------------------|
| Output high | $V_{OH} = 1/2V_{CC} + 0.2 V$ |
|-------------|------------------------------|

| | |
|------------|------------------|
| Output low | $V_{OL} = 0.8 V$ |
|------------|------------------|

Load conditions are shown in figure 15-8.

Figure 15.6 SCI3 Synchronous Mode Input/Output Timing

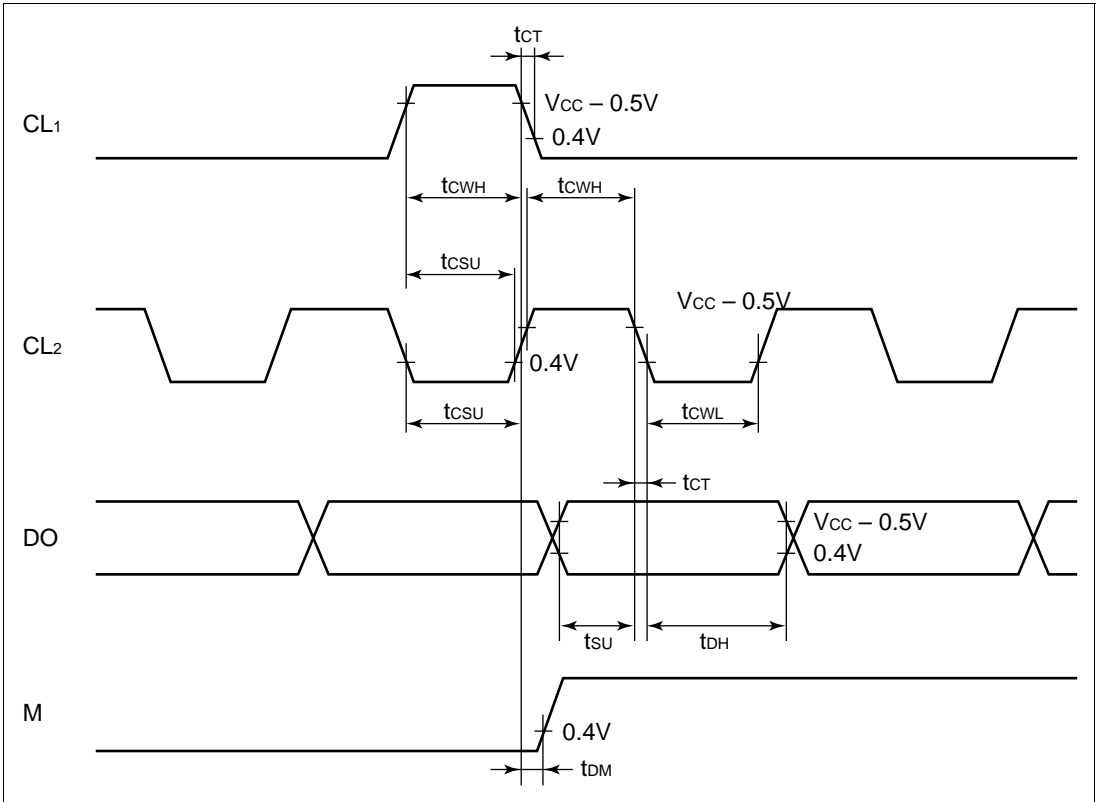

Figure 15.7 Segment Expansion Signal Timing

15.4 Output Load Circuit

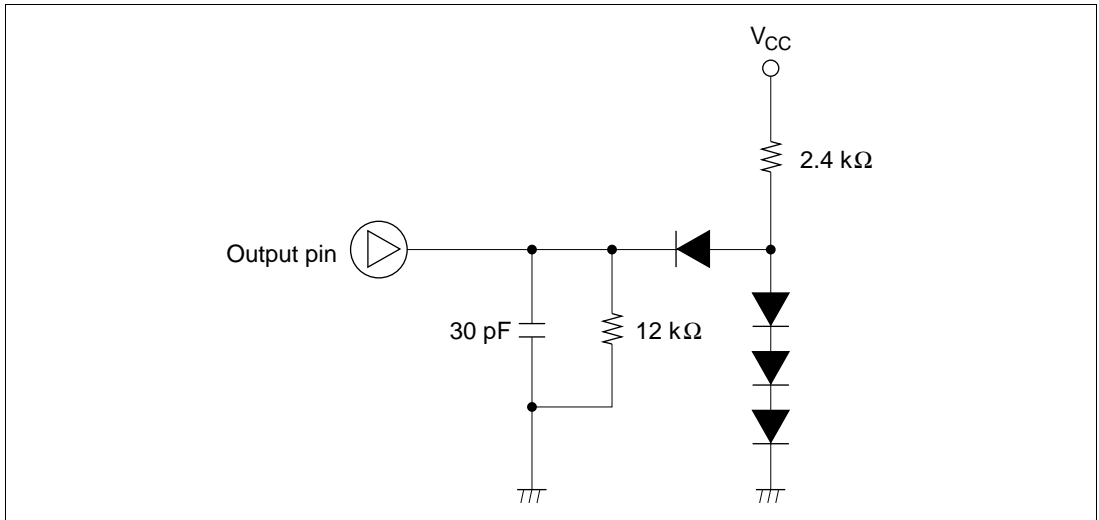

Figure 15.8 Output Load Condition

15.5 Resonator Equivalent Circuit

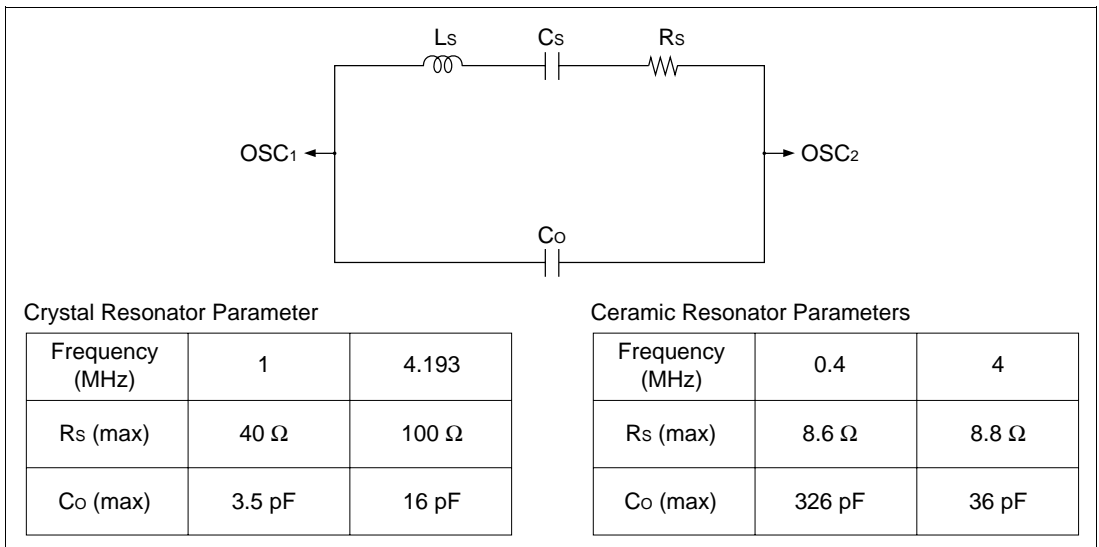

Figure 15.9 Resonator Equivalent Circuit

Appendix A CPU Instruction Set

A.1 Instructions

Operation Notation

| | |
|-------------|---|
| Rd8/16 | General register (destination) (8 or 16 bits) |
| Rs8/16 | General register (source) (8 or 16 bits) |
| Rn8/16 | General register (8 or 16 bits) |
| CCR | Condition code register |
| N | N (negative) flag in CCR |
| Z | Z (zero) flag in CCR |
| V | V (overflow) flag in CCR |
| C | C (carry) flag in CCR |
| PC | Program counter |
| SP | Stack pointer |
| #xx: 3/8/16 | Immediate data (3, 8, or 16 bits) |
| d: 8/16 | Displacement (8 or 16 bits) |
| @aa: 8/16 | Absolute address (8 or 16 bits) |
| + | Addition |
| − | Subtraction |
| × | Multiplication |
| ÷ | Division |
| ^ | Logical AND |
| ∨ | Logical OR |
| ⊕ | Exclusive logical OR |
| → | Move |
| — | Logical complement |

Condition Code Notation

Symbol

| | |
|--------|--|
| ↑ ↓ | Modified according to the instruction result |
| * | Not fixed (value not guaranteed) |
| 0 | Always cleared to 0 |
| — | Not affected by the instruction execution result |

Table A.1 Instruction Set

| Mnemonic | Operand Size | Operation | Addressing Mode/ Instruction Length (bytes) | | | | | | | | Condition Code | | | | | | No. of States | |
|-----------------------|--------------|-------------------------------|--|----|-------------|-------------|-----------|-----------|------------|-----|----------------|---|---|---|---|---|---------------|---|
| | | | #xx: 8/16 | Rn | @Rn | @(d:16, Rn) | @-Rn/@Rn+ | @aa: 8/16 | @(d:8, PC) | @aa | Implied | I | H | N | Z | V | | C |
| | | | MOV.B #xx:8, Rd | B | #xx:8 → Rd8 | 2 | | | | | | | | | — | — | | ↑ |
| MOV.B Rs, Rd | B | Rs8 → Rd8 | | 2 | | | | | | | | — | — | ↑ | ↓ | 0 | — | 2 |
| MOV.B @Rs, Rd | B | @Rs16 → Rd8 | | | 2 | | | | | | | — | — | ↑ | ↓ | 0 | — | 4 |
| MOV.B @(d:16, Rs), Rd | B | @(d:16, Rs16) → Rd8 | | | | 4 | | | | | | — | — | ↑ | ↓ | 0 | — | 6 |
| MOV.B @Rs+, Rd | B | @Rs16 → Rd8 Rs16+1 → Rs16 | | | | | 2 | | | | | — | — | ↑ | ↓ | 0 | — | 6 |
| MOV.B @aa:8, Rd | B | @aa:8 → Rd8 | | | | | | 2 | | | | — | — | ↑ | ↓ | 0 | — | 4 |
| MOV.B @aa:16, Rd | B | @aa:16 → Rd8 | | | | | | 4 | | | | — | — | ↑ | ↓ | 0 | — | 6 |
| MOV.B Rs, @Rd | B | Rs8 → @Rd16 | | | 2 | | | | | | | — | — | ↑ | ↓ | 0 | — | 4 |
| MOV.B Rs, @(d:16, Rd) | B | Rs8 → @(d:16, Rd16) | | | | 4 | | | | | | — | — | ↑ | ↓ | 0 | — | 6 |
| MOV.B Rs, @-Rd | B | Rd16-1 → Rd16 Rs8 → @Rd16 | | | | | 2 | | | | | — | — | ↑ | ↓ | 0 | — | 6 |
| MOV.B Rs, @aa:8 | B | Rs8 → @aa:8 | | | | | | 2 | | | | — | — | ↑ | ↓ | 0 | — | 4 |
| MOV.B Rs, @aa:16 | B | Rs8 → @aa:16 | | | | | | 4 | | | | — | — | ↑ | ↓ | 0 | — | 6 |
| MOV.W #xx:16, Rd | W | #xx:16 → Rd | 4 | | | | | | | | | — | — | ↑ | ↓ | 0 | — | 4 |
| MOV.W Rs, Rd | W | Rs16 → Rd16 | | 2 | | | | | | | | — | — | ↑ | ↓ | 0 | — | 2 |
| MOV.W @Rs, Rd | W | @Rs16 → Rd16 | | | 2 | | | | | | | — | — | ↑ | ↓ | 0 | — | 4 |
| MOV.W @(d:16, Rs), Rd | W | @(d:16, Rs16) → Rd16 | | | | 4 | | | | | | — | — | ↑ | ↓ | 0 | — | 6 |
| MOV.W @Rs+, Rd | W | @Rs16 → Rd16 Rs16+2 → Rs16 | | | | | 2 | | | | | — | — | ↑ | ↓ | 0 | — | 6 |
| MOV.W @aa:16, Rd | W | @aa:16 → Rd16 | | | | | | 4 | | | | — | — | ↑ | ↓ | 0 | — | 6 |
| MOV.W Rs, @Rd | W | Rs16 → @Rd16 | | | 2 | | | | | | | — | — | ↑ | ↓ | 0 | — | 4 |
| MOV.W Rs, @(d:16, Rd) | W | Rs16 → @(d:16, Rd16) | | | | 4 | | | | | | — | — | ↑ | ↓ | 0 | — | 6 |
| MOV.W Rs, @-Rd | W | Rd16-2 → Rd16 Rs16 → @Rd16 | | | | | 2 | | | | | — | — | ↑ | ↓ | 0 | — | 6 |
| MOV.W Rs, @aa:16 | W | Rs16 → @aa:16 | | | | | | 4 | | | | — | — | ↑ | ↓ | 0 | — | 6 |
| POP Rd | W | @SP → Rd16 SP+2 → SP | | | | | 2 | | | | | — | — | ↑ | ↓ | 0 | — | 6 |
| PUSH Rs | W | SP-2 → SP Rs16 → @SP | | | | | 2 | | | | | — | — | ↑ | ↓ | 0 | — | 6 |

Table A.1 Instruction Set (cont)

| Mnemonic | Operand Size | Operation | Addressing Mode/ Instruction Length (bytes) | | | | | | | | Condition Code | | | | | | No. of States | |
|------------------|--------------|--------------------------|--|----|-----|-------------|-----------|-----------|------------|------|----------------|---|---|---|---|---|-------------------|---|
| | | | #xx: 8/16 | Rn | @Rn | @(d:16, Rn) | @-Rn/@Rn+ | @aa: 8/16 | @(d:8, PC) | @@aa | Implied | I | H | N | Z | V | | C |
| | | | | | | | | | | | | | | | | | | |
| ADD.B #xx:8, Rd | B | Rd8+#xx:8 → Rd8 | 2 | | | | | | | | | | | | | | — ↓ ↓ ↓ ↓ ↓ 2 | |
| ADD.B Rs, Rd | B | Rd8+Rs8 → Rd8 | | 2 | | | | | | | | | | | | | — ↓ ↓ ↓ ↓ ↓ 2 | |
| ADD.W Rs, Rd | W | Rd16+Rs16 → Rd16 | | 2 | | | | | | | | | | | | | — (1) ↓ ↓ ↓ ↓ ↓ 2 | |
| ADDX.B #xx:8, Rd | B | Rd8+#xx:8 +C → Rd8 | 2 | | | | | | | | | | | | | | — ↓ ↓ ↓ (2) ↓ ↓ 2 | |
| ADDX.B Rs, Rd | B | Rd8+Rs8 +C → Rd8 | | 2 | | | | | | | | | | | | | — ↓ ↓ ↓ (2) ↓ ↓ 2 | |
| ADDS.W #1, Rd | W | Rd16+1 → Rd16 | | 2 | | | | | | | | | | | | | — — — — — 2 | |
| ADDS.W #2, Rd | W | Rd16+2 → Rd16 | | 2 | | | | | | | | | | | | | — — — — — 2 | |
| INC.B Rd | B | Rd8+1 → Rd8 | | 2 | | | | | | | | | | | | | — — ↓ ↓ ↓ — 2 | |
| DAA.B Rd | B | Rd8 decimal adjust → Rd8 | | 2 | | | | | | | | | | | | | — * ↓ ↓ ↓ * (3) 2 | |
| SUB.B Rs, Rd | B | Rd8-Rs8 → Rd8 | | 2 | | | | | | | | | | | | | — ↓ ↓ ↓ ↓ ↓ 2 | |
| SUB.W Rs, Rd | W | Rd16-Rs16 → Rd16 | | 2 | | | | | | | | | | | | | — (1) ↓ ↓ ↓ ↓ ↓ 2 | |
| SUBX.B #xx:8, Rd | B | Rd8-#xx:8 -C → Rd8 | 2 | | | | | | | | | | | | | | — ↓ ↓ ↓ (2) ↓ ↓ 2 | |
| SUBX.B Rs, Rd | B | Rd8-Rs8 -C → Rd8 | | 2 | | | | | | | | | | | | | — ↓ ↓ ↓ (2) ↓ ↓ 2 | |
| SUBS.W #1, Rd | W | Rd16-1 → Rd16 | | 2 | | | | | | | | | | | | | — — — — — 2 | |
| SUBS.W #2, Rd | W | Rd16-2 → Rd16 | | 2 | | | | | | | | | | | | | — — — — — 2 | |
| DEC.B Rd | B | Rd8-1 → Rd8 | | 2 | | | | | | | | | | | | | — — ↓ ↓ ↓ — 2 | |
| DAS.B Rd | B | Rd8 decimal adjust → Rd8 | | 2 | | | | | | | | | | | | | — * ↓ ↓ ↓ * — 2 | |
| NEG.B Rd | B | 0-Rd → Rd | | 2 | | | | | | | | | | | | | — ↓ ↓ ↓ ↓ ↓ 2 | |
| CMP.B #xx:8, Rd | B | Rd8-#xx:8 | 2 | | | | | | | | | | | | | | — ↓ ↓ ↓ ↓ ↓ 2 | |
| CMP.B Rs, Rd | B | Rd8-Rs8 | | 2 | | | | | | | | | | | | | — ↓ ↓ ↓ ↓ ↓ 2 | |
| CMP.W Rs, Rd | W | Rd16-Rs16 | | 2 | | | | | | | | | | | | | — (1) ↓ ↓ ↓ ↓ ↓ 2 | |

Table A.1 Instruction Set (cont)

| Mnemonic | Operand Size | Operation | Addressing Mode/ Instruction Length (bytes) | | | | | | | | Condition Code | | | | | | No. of States | | |
|-----------------|--------------|---|--|----|-----|-------------|-----------|-----------|------------|------|----------------|---|---|---|-----|-----|---------------|---|----|
| | | | #xx: 8/16 | Rn | @Rn | @(d:16, Rn) | @-Rn/@Rn+ | @aa: 8/16 | @(d:8, PC) | @@aa | Implied | I | H | N | Z | V | | C | |
| | | | | | | | | | | | | | | | | | | | |
| MULXU.B Rs, Rd | B | $Rd8 \times Rs8 \rightarrow Rd16$ | | 2 | | | | | | | | | — | — | — | — | — | — | 14 |
| DIVXU.B Rs, Rd | B | $Rd16 \div Rs8 \rightarrow Rd16$ (RdH: remainder, RdL: quotient) | | 2 | | | | | | | | | — | — | (5) | (6) | — | — | 14 |
| AND.B #xx:8, Rd | B | $Rd8 \wedge \#xx:8 \rightarrow Rd8$ | 2 | | | | | | | | | | — | — | ↑ | ↓ | 0 | — | 2 |
| AND.B Rs, Rd | B | $Rd8 \wedge Rs8 \rightarrow Rd8$ | 2 | | | | | | | | | | — | — | ↑ | ↓ | 0 | — | 2 |
| OR.B #xx:8, Rd | B | $Rd8 \vee \#xx:8 \rightarrow Rd8$ | 2 | | | | | | | | | | — | — | ↑ | ↓ | 0 | — | 2 |
| OR.B Rs, Rd | B | $Rd8 \vee Rs8 \rightarrow Rd8$ | 2 | | | | | | | | | | — | — | ↑ | ↓ | 0 | — | 2 |
| XOR.B #xx:8, Rd | B | $Rd8 \oplus \#xx:8 \rightarrow Rd8$ | 2 | | | | | | | | | | — | — | ↑ | ↓ | 0 | — | 2 |
| XOR.B Rs, Rd | B | $Rd8 \oplus Rs8 \rightarrow Rd8$ | 2 | | | | | | | | | | — | — | ↑ | ↓ | 0 | — | 2 |
| NOT.B Rd | B | $\overline{Rd} \rightarrow Rd$ | 2 | | | | | | | | | | — | — | ↑ | ↓ | 0 | — | 2 |
| SHAL.B Rd | B |  | 2 | | | | | | | | | | — | — | ↑ | ↓ | ↑ | ↓ | 2 |
| SHAR.B Rd | B |  | 2 | | | | | | | | | | — | — | ↑ | ↓ | 0 | ↑ | 2 |
| SHLL.B Rd | B |  | 2 | | | | | | | | | | — | — | ↑ | ↓ | 0 | ↑ | 2 |
| SHLR.B Rd | B |  | 2 | | | | | | | | | | — | — | 0 | ↑ | 0 | ↑ | 2 |
| ROTXL.B Rd | B |  | 2 | | | | | | | | | | — | — | ↑ | ↓ | 0 | ↑ | 2 |
| ROTXR.B Rd | B |  | 2 | | | | | | | | | | — | — | ↑ | ↓ | 0 | ↑ | 2 |

Table A.1 Instruction Set (cont)

| Mnemonic | Operand Size | Operation | | Addressing Mode/ Instruction Length (bytes) | | | | | | | Condition Code | | | | | | No. of States | | | |
|--------------------|--------------|--|---------------------------|--|-----------|----|-----|--------------|------------|------------|----------------|-------|---------|---|---|---|---------------|---|---|---|
| | | | | Branching Condition | #xx: 8/16 | Rn | @Rn | @ (d:16, Rn) | @ -Rn/@Rn+ | @ aa: 8/16 | @ (d:8, PC) | @ @aa | Implied | I | H | N | | Z | V | C |
| | | | | | | | | | | | | | | | | | | | | |
| BIOR #xx:3, @aa:8 | B | $C \vee (\#xx:3 \text{ of } @aa:8) \rightarrow C$ | | | | | | 4 | | | | — | — | — | — | — | — | ↕ | 6 | |
| BXOR #xx:3, Rd | B | $C \oplus (\#xx:3 \text{ of } Rd8) \rightarrow C$ | | 2 | | | | | | | | — | — | — | — | — | — | ↕ | 2 | |
| BXOR #xx:3, @Rd | B | $C \oplus (\#xx:3 \text{ of } @Rd16) \rightarrow C$ | | | 4 | | | | | | | — | — | — | — | — | — | ↕ | 6 | |
| BXOR #xx:3, @aa:8 | B | $C \oplus (\#xx:3 \text{ of } @aa:8) \rightarrow C$ | | | | | | 4 | | | | — | — | — | — | — | — | ↕ | 6 | |
| BIXOR #xx:3, Rd | B | $C \oplus (\#xx:3 \text{ of } Rd8) \rightarrow C$ | | 2 | | | | | | | | — | — | — | — | — | — | ↕ | 2 | |
| BIXOR #xx:3, @Rd | B | $C \oplus (\#xx:3 \text{ of } @Rd16) \rightarrow C$ | | | 4 | | | | | | | — | — | — | — | — | — | ↕ | 6 | |
| BIXOR #xx:3, @aa:8 | B | $C \oplus (\#xx:3 \text{ of } @aa:8) \rightarrow C$ | | | | | | 4 | | | | — | — | — | — | — | — | ↕ | 6 | |
| BRA d:8 (BT d:8) | — | $PC \leftarrow PC+d:8$ | | | | | | | 2 | | | — | — | — | — | — | — | — | 4 | |
| BRN d:8 (BF d:8) | — | $PC \leftarrow PC+2$ | | | | | | | 2 | | | — | — | — | — | — | — | — | 4 | |
| BHI d:8 | — | If condition is true then PC ← PC+d:8 else next; | $C \vee Z = 0$ | | | | | | 2 | | | — | — | — | — | — | — | — | 4 | |
| BLS d:8 | — | | $C \vee Z = 1$ | | | | | | | 2 | | | — | — | — | — | — | — | 4 | |
| BCC d:8 (BHS d:8) | — | | $C = 0$ | | | | | | | 2 | | | — | — | — | — | — | — | 4 | |
| BCS d:8 (BLO d:8) | — | | $C = 1$ | | | | | | | 2 | | | — | — | — | — | — | — | 4 | |
| BNE d:8 | — | | $Z = 0$ | | | | | | | 2 | | | — | — | — | — | — | — | 4 | |
| BEQ d:8 | — | | $Z = 1$ | | | | | | | 2 | | | — | — | — | — | — | — | 4 | |
| BVC d:8 | — | | $V = 0$ | | | | | | | 2 | | | — | — | — | — | — | — | 4 | |
| BVS d:8 | — | | $V = 1$ | | | | | | | 2 | | | — | — | — | — | — | — | 4 | |
| BPL d:8 | — | | $N = 0$ | | | | | | | 2 | | | — | — | — | — | — | — | 4 | |
| BMI d:8 | — | | $N = 1$ | | | | | | | 2 | | | — | — | — | — | — | — | 4 | |
| BGE d:8 | — | | $N \oplus V = 0$ | | | | | | | 2 | | | — | — | — | — | — | — | 4 | |
| BLT d:8 | — | | $N \oplus V = 1$ | | | | | | | 2 | | | — | — | — | — | — | — | 4 | |
| BGT d:8 | — | | $Z \vee (N \oplus V) = 0$ | | | | | | | 2 | | | — | — | — | — | — | — | 4 | |
| BLE d:8 | — | | $Z \vee (N \oplus V) = 1$ | | | | | | | 2 | | | — | — | — | — | — | — | 4 | |
| JMP @Rn | — | $PC \leftarrow Rn16$ | | | 2 | | | | | | | — | — | — | — | — | — | — | 4 | |
| JMP @aa:16 | — | $PC \leftarrow aa:16$ | | | | | | | 4 | | | — | — | — | — | — | — | — | 6 | |
| JMP @@aa:8 | — | $PC \leftarrow @aa:8$ | | | | | | | | 2 | | — | — | — | — | — | — | — | 8 | |
| BSR d:8 | — | SP-2 → SP PC → @SP PC ← PC+d:8 | | | | | | | 2 | | | — | — | — | — | — | — | — | 6 | |

Table A.1 Instruction Set (cont)

| Mnemonic | Operand Size | Operation | Addressing Mode/ Instruction Length (bytes) | | | | | | | | Condition Code | | | | | | No. of States | |
|-----------------|--------------|--|--|----|-----|--------------|-----------|-----------|-------------|------|----------------|---|---|---|---|---|---------------|---|
| | | | #xx: 8/16 | Rn | @Rn | @ (d:16, Rn) | @-Rn/@Rn+ | @aa: 8/16 | @ (d:8, PC) | @@aa | Implied | I | H | N | Z | V | | C |
| | | | | | | | | | | | | | | | | | | |
| JSR @Rn | — | SP-2 → SP PC → @SP PC ← Rn16 | | | 2 | | | | | | | | | | | | 6 | |
| JSR @aa:16 | — | SP-2 → SP PC → @SP PC ← aa:16 | | | | | | 4 | | | | | | | | | 8 | |
| JSR @@aa:8 | — | SP-2 → SP PC → @SP PC ← @aa:8 | | | | | | | | 2 | | | | | | | 8 | |
| RTS | — | PC ← @SP SP+2 → SP | | | | | | | | 2 | | | | | | | 8 | |
| RTE | — | CCR ← @SP SP+2 → SP PC ← @SP SP+2 → SP | | | | | | | | 2 | ↓ | ↓ | ↓ | ↓ | ↓ | ↓ | 10 | |
| SLEEP | — | Transit to sleep mode. | | | | | | | | 2 | — | — | — | — | — | — | 2 | |
| LDC #xx:8, CCR | B | #xx:8 → CCR | 2 | | | | | | | | ↓ | ↓ | ↓ | ↓ | ↓ | ↓ | 2 | |
| LDC Rs, CCR | B | Rs8 → CCR | | 2 | | | | | | | ↓ | ↓ | ↓ | ↓ | ↓ | ↓ | 2 | |
| STC CCR, Rd | B | CCR → Rd8 | | 2 | | | | | | | — | — | — | — | — | — | 2 | |
| ANDC #xx:8, CCR | B | CCR^#xx:8 → CCR | 2 | | | | | | | | ↓ | ↓ | ↓ | ↓ | ↓ | ↓ | 2 | |
| ORC #xx:8, CCR | B | CCRv#xx:8 → CCR | 2 | | | | | | | | ↓ | ↓ | ↓ | ↓ | ↓ | ↓ | 2 | |
| XORC #xx:8, CCR | B | CCR@#xx:8 → CCR | 2 | | | | | | | | ↓ | ↓ | ↓ | ↓ | ↓ | ↓ | 2 | |
| NOP | — | PC ← PC+2 | | | | | | | | 2 | — | — | — | — | — | — | 2 | |
| EEMOV | — | if R4L≠0 Repeat @R5 → @R6 R5+1 → R5 R6+1 → R6 R4L-1 → R4L Until R4L=0 else next; | | | | | | | | 4 | — | — | — | — | — | — | (4) | |

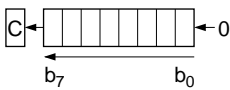
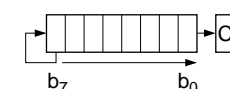
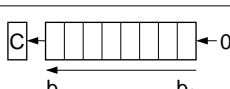
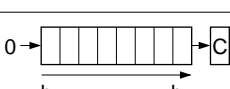
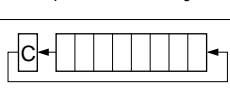
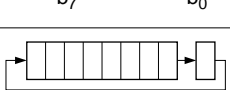
- Notes: (1) Set to 1 when there is a carry or borrow from bit 11; otherwise cleared to 0.
(2) If the result is zero, the previous value of the flag is retained; otherwise the flag is cleared to 0.
(3) Set to 1 if decimal adjustment produces a carry; otherwise retains value prior to arithmetic operation.
(4) The number of states required for execution is 4n + 9 (n = value of R4L).
(5) Set to 1 if the divisor is negative; otherwise cleared to 0.
(6) Set to 1 if the divisor is zero; otherwise cleared to 0.

A.2 Operation Code Map

Table A.2 is an operation code map. It shows the operation codes contained in the first byte of the instruction code (bits 15 to 8 of the first instruction word).

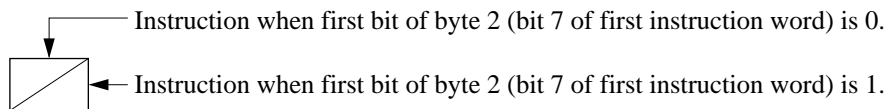

Table A.2 Operation Code Map

| Low High | 0 | 1 | 2 | 3 | 4 | 5 | 6 | 7 | 8 | 9 | A | B | C | D | E | F |
|-------------|--------------|--------------|---------------|---------------|-----|------|------|------------|------|------|------|------|-------|-------------------------------|------|-----|
| 0 | NOP | SLEEP | STC | LDC | ORC | XORC | ANDC | LDC | ADD | | INC | ADDS | MOV | | ADDX | DAA |
| 1 | SHLL SHAL | SHLR SHAR | ROTXL ROTL | ROTXR ROTR | OR | XOR | AND | NOT NEG | SUB | | DEC | SUBS | CMP | | SUBX | DAS |
| 2 | MOV | | | | | | | | | | | | | | | |
| 3 | MOV | | | | | | | | | | | | | | | |
| 4 | BRA | BRN | BHI | BLS | BCC | BCS | BNE | BEQ | BVC | BVS | BPL | BMI | BGE | BLT | BGT | BLE |
| 5 | MULXU | DIVXU | RTS | | RTE | BSR | JMP | JMP | | JMP | | JMP | | JSR | | |
| 6 | MOV* | | | | | | | | | | | | | | | |
| 7 | BSET | BNOT | BCLR | BTST | BOR | BXOR | BAND | BST | BBLD | BBLD | BBLD | BBLD | EEMOV | Bit-manipulation instructions | | |
| 8 | ADD | | | | | | | | | | | | | | | |
| 9 | ADDX | | | | | | | | | | | | | | | |
| A | CMP | | | | | | | | | | | | | | | |
| B | SUBX | | | | | | | | | | | | | | | |
| C | OR | | | | | | | | | | | | | | | |
| D | XOR | | | | | | | | | | | | | | | |
| E | AND | | | | | | | | | | | | | | | |
| F | MOV | | | | | | | | | | | | | | | |

Note: * The PUSH and POP instructions are identical in machine language to MOV instructions.

A.3 Number of Execution States

The tables here can be used to calculate the number of states required for instruction execution. Table A.4 indicates the number of states required for each cycle (instruction fetch, read/write, etc.), and table A.3 indicates the number of cycles of each type occurring in each instruction. The total number of states required for execution of an instruction can be calculated from these two tables as follows:

$$\text{Execution states} = I \times S_I + J \times S_J + K \times S_K + L \times S_L + M \times S_M + N \times S_N$$

Examples: When instruction is fetched from on-chip ROM, and an on-chip RAM is accessed.

BSET #0, @FF00

From table A.4:

$$I = L = 2, \quad J = K = M = N = 0$$

From table A.3:

$$S_I = 2, \quad S_L = 2$$

$$\text{Number of states required for execution} = 2 \times 2 + 2 \times 2 = 8$$

When instruction is fetched from on-chip ROM, branch address is read from on-chip ROM, and on-chip RAM is used for stack area.

JSR @@ 30

From table A.4:

$$I = 2, \quad J = K = 1, \quad L = M = N = 0$$

From table A.3:

$$S_I = S_J = S_K = 2$$

$$\text{Number of states required for execution} = 2 \times 2 + 1 \times 2 + 1 \times 2 = 8$$

Table A.3 Number of Cycles in Each Instruction

| Execution Status (instruction cycle) | | Access Location | |
|---|-------|------------------------|----------------------------------|
| | | On-Chip Memory | On-Chip Peripheral Module |
| Instruction fetch | S_I | 2 | — |
| Branch address read | S_J | | |
| Stack operation | S_K | | |
| Byte data access | S_L | | 2 or 3* |
| Word data access | S_M | | — |
| Internal operation | S_N | 1 | |

Note: * Depends on which on-chip module is accessed. See 2.9.1, Notes on Data Access for details.

Table A.4 Number of Cycles in Each Instruction

| Instruction | Mnemonic | Instruction Fetch I | Branch Addr. Read J | Stack Operation K | Byte Data Access L | Word Data Access M | Internal Operation N |
|-------------|--------------------|---------------------------|---------------------------|-------------------------|--------------------------|--------------------------|----------------------------|
| ADD | ADD.B #xx:8, Rd | 1 | | | | | |
| | ADD.B Rs, Rd | 1 | | | | | |
| | ADD.W Rs, Rd | 1 | | | | | |
| ADDS | ADDS.W #1, Rd | 1 | | | | | |
| | ADDS.W #2, Rd | 1 | | | | | |
| ADDX | ADDX.B #xx:8, Rd | 1 | | | | | |
| | ADDX.B Rs, Rd | 1 | | | | | |
| AND | AND.B #xx:8, Rd | 1 | | | | | |
| | AND.B Rs, Rd | 1 | | | | | |
| ANDC | ANDC #xx:8, CCR | 1 | | | | | |
| BAND | BAND #xx:3, Rd | 1 | | | | | |
| | BAND #xx:3, @Rd | 2 | | | 1 | | |
| | BAND #xx:3, @aa:8 | 2 | | | 1 | | |
| Bcc | BRA d:8 (BT d:8) | 2 | | | | | |
| | BRN d:8 (BF d:8) | 2 | | | | | |
| | BHI d:8 | 2 | | | | | |
| | BLS d:8 | 2 | | | | | |
| | BCC d:8 (BHS d:8) | 2 | | | | | |
| | BCS d:8 (BLO d:8) | 2 | | | | | |
| | BNE d:8 | 2 | | | | | |
| | BEQ d:8 | 2 | | | | | |
| | BVC d:8 | 2 | | | | | |
| | BVS d:8 | 2 | | | | | |
| | BPL d:8 | 2 | | | | | |
| | BMI d:8 | 2 | | | | | |
| | BGE d:8 | 2 | | | | | |
| | BLT d:8 | 2 | | | | | |
| | BGT d:8 | 2 | | | | | |
| BLE d:8 | 2 | | | | | | |
| BCLR | BCLR #xx:3, Rd | 1 | | | | | |
| | BCLR #xx:3, @Rd | 2 | | | 2 | | |
| | BCLR #xx:3, @aa:8 | 2 | | | 2 | | |
| | BCLR Rn, Rd | 1 | | | | | |
| | BCLR Rn, @Rd | 2 | | | 2 | | |
| | BCLR Rn, @aa:8 | 2 | | | 2 | | |
| BIAND | BIAND #xx:3, Rd | 1 | | | | | |
| | BIAND #xx:3, @Rd | 2 | | | 1 | | |
| | BIAND #xx:3, @aa:8 | 2 | | | 1 | | |

Table A.4 Number of Cycles in Each Instruction (cont)

| Instruction | Mnemonic | Instruction | Branch | Stack | Byte Data | Word Data | Internal |
|-------------|--------------------|-------------|-----------------|----------------|-------------|-------------|----------------|
| | | Fetch I | Addr. Read J | Operation K | Access L | Access M | Operation N |
| BILD | BILD #xx:3, Rd | 1 | | | | | |
| | BILD #xx:3, @Rd | 2 | | | 1 | | |
| | BILD #xx:3, @aa:8 | 2 | | | 1 | | |
| BIOR | BIOR #xx:3, Rd | 1 | | | | | |
| | BIOR #xx:3, @Rd | 2 | | | 1 | | |
| | BIOR #xx:3, @aa:8 | 2 | | | 1 | | |
| BIST | BIST #xx:3, Rd | 1 | | | | | |
| | BIST #xx:3, @Rd | 2 | | | 2 | | |
| | BIST #xx:3, @aa:8 | 2 | | | 2 | | |
| BIXOR | BIXOR #xx:3, Rd | 1 | | | | | |
| | BIXOR #xx:3, @Rd | 2 | | | 1 | | |
| | BIXOR #xx:3, @aa:8 | 2 | | | 1 | | |
| BLD | BLD #xx:3, Rd | 1 | | | | | |
| | BLD #xx:3, @Rd | 2 | | | 1 | | |
| | BLD #xx:3, @aa:8 | 2 | | | 1 | | |
| BNOT | BNOT #xx:3, Rd | 1 | | | | | |
| | BNOT #xx:3, @Rd | 2 | | | 2 | | |
| | BNOT #xx:3, @aa:8 | 2 | | | 2 | | |
| | BNOT Rn, Rd | 1 | | | | | |
| | BNOT Rn, @Rd | 2 | | | 2 | | |
| | BNOT Rn, @aa:8 | 2 | | | 2 | | |
| BOR | BOR #xx:3, Rd | 1 | | | | | |
| | BOR #xx:3, @Rd | 2 | | | 1 | | |
| | BOR #xx:3, @aa:8 | 2 | | | 1 | | |
| BSET | BSET #xx:3, Rd | 1 | | | | | |
| | BSET #xx:3, @Rd | 2 | | | 2 | | |
| | BSET #xx:3, @aa:8 | 2 | | | 2 | | |
| | BSET Rn, Rd | 1 | | | | | |
| | BSET Rn, @Rd | 2 | | | 2 | | |
| | BSET Rn, @aa:8 | 2 | | | 2 | | |
| BSR | BSR d:8 | 2 | | 1 | | | |
| BST | BST #xx:3, Rd | 1 | | | | | |
| | BST #xx:3, @Rd | 2 | | | 2 | | |
| | BST #xx:3, @aa:8 | 2 | | | 2 | | |
| BTST | BTST #xx:3, Rd | 1 | | | | | |
| | BTST #xx:3, @Rd | 2 | | | 1 | | |
| | BTST #xx:3, @aa:8 | 2 | | | 1 | | |
| | BTST Rn, Rd | 1 | | | | | |
| | BTST Rn, @Rd | 2 | | | 1 | | |

Table A.4 Number of Cycles in Each Instruction (cont)

| Instruction | Mnemonic | Instruction Fetch I | Branch Addr. Read J | Stack Operation K | Byte Data Access L | Word Data Access M | Internal Operation N |
|------------------|-----------------------|---------------------------|---------------------------|-------------------------|--------------------------|--------------------------|----------------------------|
| BTST | BTST Rn, @aa:8 | 2 | | | 1 | | |
| BXOR | BXOR #xx:3, Rd | 1 | | | | | |
| | BXOR #xx:3, @Rd | 2 | | | 1 | | |
| | BXOR #xx:3, @aa:8 | 2 | | | 1 | | |
| CMP | CMP. B #xx:8, Rd | 1 | | | | | |
| | CMP. B Rs, Rd | 1 | | | | | |
| | CMP.W Rs, Rd | 1 | | | | | |
| DAA | DAA.B Rd | 1 | | | | | |
| DAS | DAS.B Rd | 1 | | | | | |
| DEC | DEC.B Rd | 1 | | | | | |
| DIVXU | DIVXU.B Rs, Rd | 1 | | | | | 12 |
| EEPMOV | EEPMOV | 2 | | | 2n+2* | | 1 |
| INC | INC.B Rd | 1 | | | | | |
| JMP | JMP @Rn | 2 | | | | | |
| | JMP @aa:16 | 2 | | | | | 2 |
| | JMP @@aa:8 | 2 | 1 | | | | 2 |
| JSR | JSR @Rn | 2 | | 1 | | | |
| | JSR @aa:16 | 2 | | 1 | | | 2 |
| | JSR @@aa:8 | 2 | 1 | 1 | | | |
| LDC | LDC #xx:8, CCR | 1 | | | | | |
| | LDC Rs, CCR | 1 | | | | | |
| MOV | MOV.B #xx:8, Rd | 1 | | | | | |
| | MOV.B Rs, Rd | 1 | | | | | |
| | MOV.B @Rs, Rd | 1 | | | 1 | | |
| | MOV.B @(d:16, Rs), Rd | 2 | | | 1 | | |
| | MOV.B @Rs+, Rd | 1 | | | 1 | | 2 |
| | MOV.B @aa:8, Rd | 1 | | | 1 | | |
| | MOV.B @aa:16, Rd | 2 | | | 1 | | |
| | MOV.B Rs, @Rd | 1 | | | 1 | | |
| | MOV.B Rs, @(d:16, Rd) | 2 | | | 1 | | |
| | MOV.B Rs, @-Rd | 1 | | | 1 | | 2 |
| | MOV.B Rs, @aa:8 | 1 | | | 1 | | |
| | MOV.B Rs, @aa:16 | 2 | | | 1 | | |
| | MOV.W #xx:16, Rd | 2 | | | | | |
| | MOV.W Rs, Rd | 1 | | | | | |
| | MOV.W @Rs, Rd | 1 | | | | 1 | |
| | MOV.W @(d:16, Rs), Rd | 2 | | | | 1 | |
| | MOV.W @Rs+, Rd | 1 | | | | 1 | 2 |
| MOV.W @aa:16, Rd | 2 | | | | 1 | | |

Note: n: Initial value in R4L. The source and destination operands are accessed n + 1 times each.

Table A.4 Number of Cycles in Each Instruction (cont)

| Instruction | Mnemonic | Instruction Fetch I | Branch Addr. Read J | Stack Operation K | Byte Data Access L | Word Data Access M | Internal Operation N |
|-------------|-----------------------|---------------------------|---------------------------|-------------------------|--------------------------|--------------------------|----------------------------|
| MOV | MOV.W Rs, @Rd | 1 | | | | 1 | |
| | MOV.W Rs, @(d:16, Rd) | 2 | | | | 1 | |
| | MOV.W Rs, @-Rd | 1 | | | | 1 | 2 |
| | MOV.W Rs, @aa:16 | 2 | | | | 1 | |
| MULXU | MULXU.B Rs, Rd | 1 | | | | | 12 |
| NEG | NEG.B Rd | 1 | | | | | |
| NOP | NOP | 1 | | | | | |
| NOT | NOT.B Rd | 1 | | | | | |
| OR | OR.B #xx:8, Rd | 1 | | | | | |
| | OR.B Rs, Rd | 1 | | | | | |
| ORC | ORC #xx:8, CCR | 1 | | | | | |
| ROTL | ROTL.B Rd | 1 | | | | | |
| ROTR | ROTR.B Rd | 1 | | | | | |
| ROTXL | ROTXL.B Rd | 1 | | | | | |
| ROTXR | ROTXR.B Rd | 1 | | | | | |
| RTE | RTE | 2 | | 2 | | | 2 |
| RTS | RTS | 2 | | 1 | | | 2 |
| SHAL | SHAL.B Rd | 1 | | | | | |
| SHAR | SHAR.B Rd | 1 | | | | | |
| SHLL | SHLL.B Rd | 1 | | | | | |
| SHLR | SHLR.B Rd | 1 | | | | | |
| SLEEP | SLEEP | 1 | | | | | |
| STC | STC CCR, Rd | 1 | | | | | |
| SUB | SUB.B Rs, Rd | 1 | | | | | |
| | SUB.W Rs, Rd | 1 | | | | | |
| SUBS | SUBS.W #1, Rd | 1 | | | | | |
| | SUBS.W #2, Rd | 1 | | | | | |
| POP | POP Rd | 1 | | 1 | | | 2 |
| PUSH | PUSH Rs | 1 | | 1 | | | 2 |
| SUBX | SUBX.B #xx:8, Rd | 1 | | | | | |
| | SUBX.B Rs, Rd | 1 | | | | | |
| XOR | XOR.B #xx:8, Rd | 1 | | | | | |
| | XOR.B Rs, Rd | 1 | | | | | |
| XORC | XORC #xx:8, CCR | 1 | | | | | |

Appendix B Internal I/O Registers

B.1 Addresses

| Lower Address | Register Name | Bit Names | | | | | | | | Module Name |
|---------------|---------------|-----------|--------|--------|--------|--------|--------|--------|--------|----------------|
| | | Bit 7 | Bit 6 | Bit 5 | Bit 4 | Bit 3 | Bit 2 | Bit 1 | Bit 0 | |
| H'90 | WEGR | WKEGS7 | WKEGS6 | WKEGS5 | WKEGS4 | WKEGS3 | WKEGS2 | WKEGS1 | WKEGS0 | System control |
| H'91 | SPCR | — | — | SPC32 | SPC31 | SCINV3 | SCINV2 | SCINV1 | SCINV0 | SCI |
| H'92 | CWOSR | — | — | — | — | — | — | — | CWOS | Timer A |
| H'93 | | | | | | | | | | |
| H'94 | | | | | | | | | | |
| H'95 | ECCSR | OVH | OVL | — | CH2 | CUEH | CUEL | CRCH | CRCL | Asynchro- |
| H'96 | ECH | ECH7 | ECH6 | ECH5 | ECH4 | ECH3 | ECH2 | ECH1 | ECH0 | nous event |
| H'97 | ECL | ECL7 | ECL6 | ECL5 | ECL4 | ECL3 | ECL2 | ECL1 | ECL0 | counter |
| H'98 | SMR31 | COM31 | CHR31 | PE31 | PM31 | STOP31 | MP31 | CKS311 | CKS310 | SCI31 |
| H'99 | BRR31 | BRR317 | BRR316 | BRR315 | BRR314 | BRR313 | BRR312 | BRR311 | BRR310 | |
| H'9A | SCR31 | TIE31 | RIE31 | TE31 | RE31 | MPIE31 | TEIE31 | CKE31 | CKE310 | |
| H'9B | TDR31 | TDR317 | TDR316 | TDR315 | TDR314 | TDR313 | TDR312 | TDR311 | TDR310 | |
| H'9C | SSR31 | TDRE31 | RDRF31 | OER31 | FER31 | PER31 | TEND31 | MPBR31 | MPBT31 | |
| H'9D | RDR31 | RDR317 | RDR316 | RDR315 | RDR314 | RDR313 | RDR312 | RDR311 | RDR310 | |
| H'9E | | | | | | | | | | |
| H'9F | | | | | | | | | | |
| H'A0 | | | | | | | | | | |
| H'A1 | | | | | | | | | | |
| H'A2 | | | | | | | | | | |
| H'A3 | | | | | | | | | | |
| H'A4 | | | | | | | | | | |
| H'A5 | | | | | | | | | | |
| H'A6 | | | | | | | | | | |
| H'A7 | | | | | | | | | | |
| H'A8 | SMR32 | COM32 | CHR32 | PE32 | PM32 | STOP32 | MP32 | CKS321 | CKS320 | SCI32 |
| H'A9 | BRR32 | BRR327 | BRR326 | BRR325 | BRR324 | BR323 | BRR322 | BRR321 | BRR320 | |
| H'AA | SCR32 | TIE32 | RIE32 | TE32 | RE32 | MPIE32 | TEIE32 | CKE321 | CKE320 | |
| H'AB | TDR32 | TDR327 | TDR326 | TDR325 | TDR324 | TDR323 | TDR322 | TDR321 | TDR320 | |
| H'AC | SSR32 | TDRE32 | RDRF32 | OER32 | FER32 | PER32 | TEND32 | MPBR32 | MPBT32 | |
| H'AD | RDR32 | RDR327 | RDR326 | RDR325 | RDR324 | RDR323 | RDR322 | RDR321 | RDR320 | |
| H'AE | | | | | | | | | | |
| H'AF | | | | | | | | | | |
| H'B0 | TMA | TMA7 | TMA6 | TMA5 | — | TMA3 | TMA2 | TMA1 | TMA0 | Timer A |

| Lower Address | Register Name | Bit Names | | | | | | | | Module Name |
|---------------|---------------|--------------|---------------|---------------|---------------|---------------|---------------|---------------|---------------|---------------------------|
| | | Bit 7 | Bit 6 | Bit 5 | Bit 4 | Bit 3 | Bit 2 | Bit 1 | Bit 0 | |
| H'B1 | TCA | TCA7 | TCA6 | TCA5 | TCA4 | TCA3 | TCA2 | TCA1 | TCA0 | Timer A |
| H'B2 | TCSRW | B6WI | TCWE | B4WI | TCSRWE | B2WI | WDON | BOW1 | WRST | Watchdog timer |
| H'B3 | TCW | TCW7 | TCW6 | TCW5 | TCW4 | TCW3 | TCW2 | TCW1 | TCW0 | |
| H'B4 | TMC | TMC7 | TMC6 | TMC5 | — | — | TMC2 | TMC1 | TMC0 | Timer C |
| H'B5 | TCC/TLC | TCC/ TLC7 | TCC6/ TLC6 | TCC5/ TLC5 | TCC4/ TLC4 | TCC3/ TLC3 | TCC2/ TLC2 | TCC1/ TLC1 | TCC0/ TLC0 | |
| H'B6 | TCRF | TOLH | CKSH2 | CKSH1 | CKSH0 | TOLL | CKSL2 | CKSL1 | CKSL0 | Timer F |
| H'B7 | TCSRF | OVFH | CMFH | OVIEH | CCLRH | OVFL | CMFL | OVIEL | CCLRL | |
| H'B8 | TCFH | TCFH7 | TCFH6 | TCFH5 | TCFH4 | TCFH3 | TCFH2 | TCFH1 | TCFH0 | |
| H'B9 | TCFL | TCFL7 | TCFL6 | TCFL5 | TCFL4 | TCFL3 | TCFL2 | TCFL1 | TCFL0 | |
| H'BA | OCRFH | OCRFH7 | OCRFH6 | OCRFH5 | OCRFH4 | OCRFH3 | OCRFH2 | OCRFH1 | OCRFH0 | |
| H'BB | OCRFL | OCRFL7 | OCRFL6 | OCRFL5 | OCRFL4 | OCRFL3 | OCRFL2 | OCRFL1 | OCRFL0 | |
| H'BC | TMG | OVFH | OVFL | OVIE | IIEGS | CCLR1 | CCLR0 | CKS1 | CKS0 | Timer G |
| H'BD | ICRGF | ICRGF7 | ICRGF6 | ICRGF5 | ICRGF4 | ICRGF3 | ICRGF2 | ICRGF1 | ICRGF0 | |
| H'BE | ICRGR | ICRGR7 | ICRGR6 | ICRGR5 | ICRGR4 | ICRGR3 | ICRGR2 | ICRGR1 | ICRGR0 | |
| H'BF | | | | | | | | | | |
| H'C0 | LPCR | DTS1 | DTS0 | CMX | SGX | SGS3 | SGS2 | SGS1 | SGS0 | LCD |
| H'C1 | LCR | — | PSW | ACT | DISP | CKS3 | CKS2 | CKS1 | CKS0 | LCD controller/ driver |
| H'C2 | LCR2 | LCDAB | — | — | SUPS | CDS3 | CDS2 | CDS1 | CDS0 | |
| H'C3 | | | | | | | | | | |
| H'C4 | ADRRH | ADR9 | ADR8 | ADR7 | ADR6 | ADR5 | ADR4 | ADR3 | ADR2 | A/D converter |
| H'C5 | ADRRL | ADR1 | ADR0 | — | — | — | — | — | — | |
| H'C6 | AMR | CKS | TRGE | — | — | CH3 | CH2 | CH1 | CH0 | |
| H'C7 | ADSR | ADSF | — | — | — | — | — | — | — | |
| H'C8 | PMR1 | IRQ3 | IRQ2 | IRQ1 | IRQ4 | TMIG | TMOFH | TMOFL | TMOW | I/O port |
| H'C9 | | | | | | | | | | |
| H'CA | PMR3 | AEVL | AEVH | WDCKS | NCS | IRQ0 | RESO | UD | PWM | |
| H'CB | | | | | | | | | | |
| H'CC | PMR5 | WKP7 | WKP6 | WKP5 | WKP4 | WKP3 | WKP2 | WKP1 | WKP0 | |
| H'CD | | | | | | | | | | |
| H'CE | | | | | | | | | | |
| H'CF | | | | | | | | | | |
| H'D0 | PWCR | — | — | — | — | — | — | PWCR1 | PWCR0 | Bit 14 |
| H'D1 | PWDRU | — | — | PWDRU5 | PWDRU4 | PWDRU3 | PWDRU2 | PWDRU1 | PWDRU0 | PWM |
| H'D2 | PWDRL | PWDRL7 | PWDRL6 | PWDRL5 | PWDRL4 | PWDRL3 | PWDRL2 | PWDRL1 | PWDRL0 | |
| H'D3 | | | | | | | | | | |
| H'D4 | PDR1 | P17 | P16 | P15 | P14 | P13 | P12 | P11 | P10 | I/O Port |

| Lower Address | Register Name | Bit Names | | | | | | | | Module Name |
|---------------|---------------|-----------|--------|--------|--------|--------|--------|--------|--------|----------------|
| | | Bit 7 | Bit 6 | Bit 5 | Bit 4 | Bit 3 | Bit 2 | Bit 1 | Bit 0 | |
| H'D5 | | | | | | | | | | I/O Port |
| H'D6 | PDR3 | P37 | P36 | P35 | P34 | P33 | P32 | P31 | P30 | |
| H'D7 | PDR4 | — | — | — | — | P43 | P42 | P41 | P40 | |
| H'D8 | PDR5 | P57 | P56 | P55 | P54 | P53 | P52 | P51 | P50 | |
| H'D9 | PDR6 | P67 | P66 | P65 | P64 | P63 | P62 | P61 | P60 | |
| H'DA | PDR7 | P77 | P76 | P75 | P74 | P73 | P72 | P71 | P70 | |
| H'DB | PDR8 | P87 | P86 | P85 | P84 | P83 | P82 | P81 | P80 | |
| H'DC | | | | | | | | | | |
| H'DD | PDRA | — | — | — | — | PA3 | PA2 | PA1 | PA0 | |
| H'DE | PDRB | PB7 | PB6 | PB5 | PB4 | PB3 | PB2 | PB1 | PB0 | |
| H'DF | | | | | | | | | | |
| H'E0 | PUCR1 | PUCR17 | PUCR16 | PUCR15 | PUCR14 | PUCR13 | PUCR12 | PUCR11 | PUCR10 | I/O Port |
| H'E1 | PUCR3 | PUCR37 | PUCR36 | PUCR35 | PUCR34 | PUCR33 | PUCR32 | PUCR31 | PUCR30 | |
| H'E2 | PUCR5 | PUCR57 | PUCR56 | PUCR55 | PUCR54 | PUCR53 | PUCR52 | PUCR51 | PUCR50 | |
| H'E3 | PUCR6 | PUCR67 | PUCR66 | PUCR65 | PUCR64 | PUCR63 | PUCR62 | PUCR61 | PUCR60 | |
| H'E4 | PCR1 | PCR17 | PCR16 | PCR15 | PCR14 | PCR13 | PCR12 | PCR11 | PCR10 | |
| H'E5 | | | | | | | | | | |
| H'E6 | PCR3 | PCR37 | PCR36 | PCR35 | PCR34 | PCR33 | PCR32 | PCR31 | PCR30 | |
| H'E7 | PCR4 | — | — | — | — | — | PCR42 | PCR41 | PCR40 | |
| H'E8 | PCR5 | PCR57 | PCR56 | PCR55 | PCR54 | PCR53 | PCR52 | PCR51 | PCR50 | |
| H'E9 | PCR6 | PCR67 | PCR66 | PCR65 | PCR64 | PCR63 | PCR62 | PCR61 | PCR60 | |
| H'EA | PCR7 | PCR77 | PCR76 | PCR75 | PCR74 | PCR73 | PCR72 | PCR71 | PCR70 | |
| H'EB | PCR8 | PCR87 | PCR86 | PCR85 | PCR84 | PCR83 | PCR82 | PCR81 | PCR80 | |
| H'EC | | | | | | | | | | |
| H'ED | PCRA | — | — | — | — | PCRA3 | PCRA2 | PCRA1 | PCRA0 | |
| H'EE | | | | | | | | | | |
| H'EF | | | | | | | | | | |
| H'F0 | SYSCR1 | SSBY | STS2 | STS1 | STS0 | LSON | — | MA1 | MA0 | System control |
| H'F1 | SYSCR2 | — | — | — | NESEL | DTON | MSON | SA1 | SA0 | |
| H'F2 | IEGR | — | — | — | IEG4 | IEG3 | IEG2 | IEG1 | IEG0 | |
| H'F3 | IENR1 | IENTA | — | IENWP | IEN4 | IEN3 | IEN2 | IEN1 | IEN0 | |
| H'F4 | IENR2 | IENDT | IENAD | — | IENTG | IENTFH | IENTFL | IENTC | IENEC | |
| H'F5 | | | | | | | | | | |
| H'F6 | IRR1 | IRRTA | — | — | IRRI4 | IRRI3 | IRRI2 | IRRI1 | IRRI0 | |
| H'F7 | IRR2 | IRRDT | IRRAD | — | IRRTG | IRRTFH | IRRTFL | IRRTC | IRREC | |
| H'F8 | | | | | | | | | | |

| Lower Address | Register Name | Bit Names | | | | | | | | Module Name |
|---------------|---------------|-----------|----------|----------|---------|---------|---------|---------|---------|-------------|
| | | Bit 7 | Bit 6 | Bit 5 | Bit 4 | Bit 3 | Bit 2 | Bit 1 | Bit 0 | |
| H'F9 | IWPR | IWPF7 | IWPF6 | IWPF5 | IWPF4 | IWPF3 | IWPF2 | IWPF1 | IWPF0 | System |
| H'FA | CKSTPR1 | — | S31CKSTP | S32CKSTP | ADCKSTP | TGCKSTP | TFCKSTP | TCCKSTP | TACKSTP | control |
| H'FB | CKSTPR2 | — | — | — | — | AECKSTP | WDCKSTP | PWCKSTP | LDCKSTP | |
| H'FC | | | | | | | | | | |
| H'FD | | | | | | | | | | |
| H'FE | | | | | | | | | | |
| H'FF | | | | | | | | | | |

Legend

SCI: Serial Communication Interface

| | | | | | | | | |
|---------------|--------|--------|--------|--------|--------|--------|--------|--------|
| Bit | 7 | 6 | 5 | 4 | 3 | 2 | 1 | 0 |
| | WKEGS7 | WKEGS6 | WKEGS5 | WKEGS4 | WKEGS3 | WKEGS2 | WKEGS1 | WKEGS0 |
| Initial value | 0 | 0 | 0 | 0 | 0 | 0 | 0 | 0 |
| Read/Write | R/W | R/W | R/W | R/W | R/W | R/W | R/W | R/W |

WKPN edge selected

| | |
|---|--------------------------------|
| 0 | WKPN pin falling edge detected |
| 1 | WKPN pin rising edge detected |

(n = 0 to 7)

| | | | | | | | | |
|---------------|---|---|-------|-------|--------|--------|--------|--------|
| Bit | 7 | 6 | 5 | 4 | 3 | 2 | 1 | 0 |
| | — | — | SPC32 | SPC31 | SCINV3 | SCINV2 | SCINV1 | SCINV0 |
| Initial value | 1 | 1 | 0 | 0 | 0 | 0 | 0 | 0 |
| Read/Write | — | — | R/W | R/W | R/W | R/W | R/W | R/W |

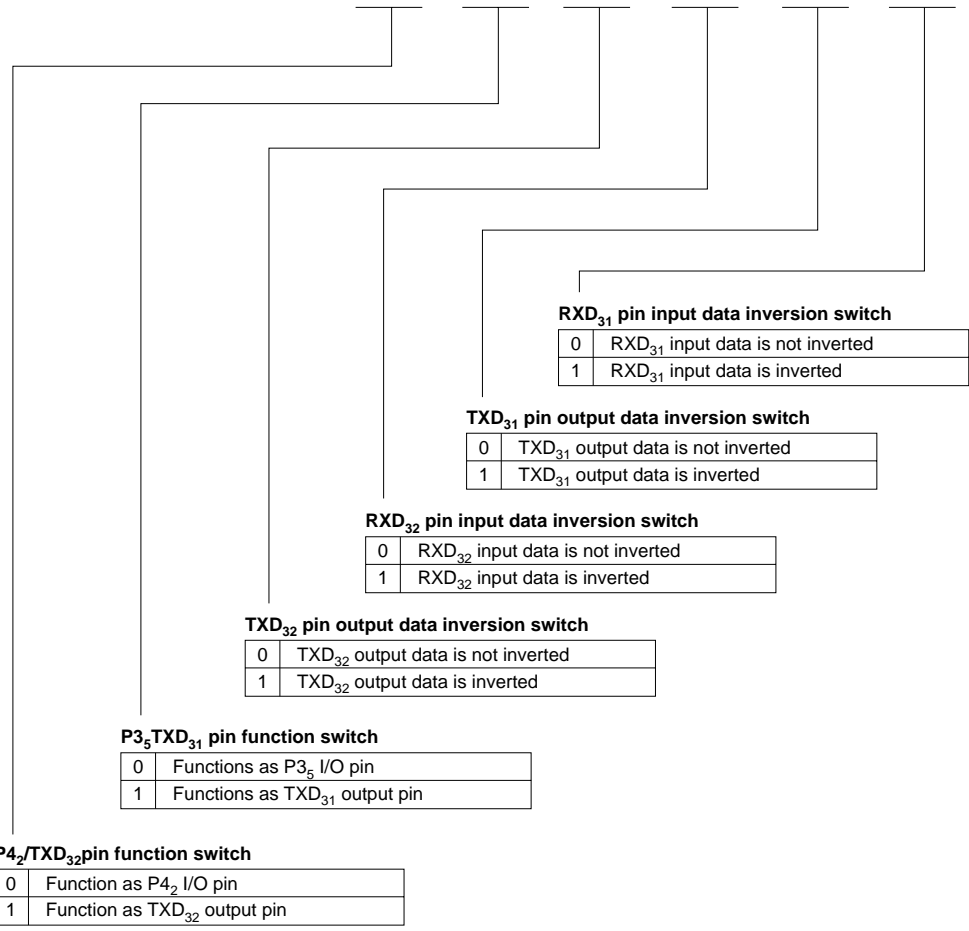

| | | | | | | | | |
|---------------|---|---|---|---|---|---|---|------|
| Bit | 7 | 6 | 5 | 4 | 3 | 2 | 1 | 0 |
| | — | — | — | — | — | — | — | CWOS |
| Initial value | 1 | 1 | 1 | 1 | 1 | 1 | 1 | 0 |
| Read/Write | R | R | R | R | R | R | R | R/W |

TMOW pin clock select

| | |
|---|---------------------------------|
| 0 | Clock output from TMA is output |
| 1 | ϕ_W is output |

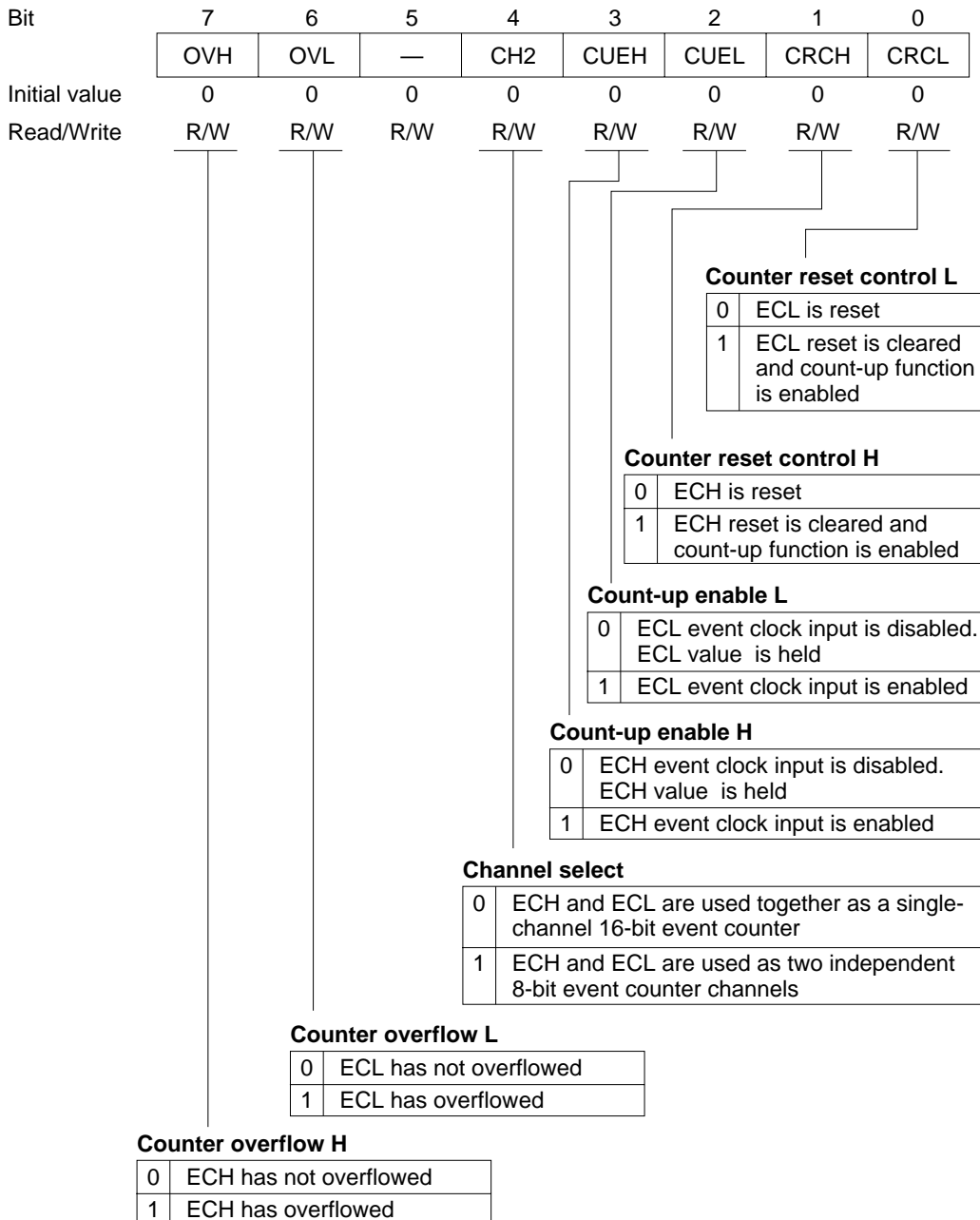

ECH—Event counter H**H'96****AEC**

| Bit | 7 | 6 | 5 | 4 | 3 | 2 | 1 | 0 |
|---------------|------|------|------|------|------|------|------|------|
| | ECH7 | ECH6 | ECH5 | ECH4 | ECH3 | ECH2 | ECH1 | ECH0 |
| Initial value | 0 | 0 | 0 | 0 | 0 | 0 | 0 | 0 |
| Read/Write | R | R | R | R | R | R | R | R |

ECL—Event counter L**H'97****AEC**

| Bit | 7 | 6 | 5 | 4 | 3 | 2 | 1 | 0 |
|---------------|------|------|------|------|------|------|------|------|
| | ECL7 | ECL6 | ECL5 | ECL4 | ECL3 | ECL2 | ECL1 | ECL0 |
| Initial value | 0 | 0 | 0 | 0 | 0 | 0 | 0 | 0 |
| Read/Write | R | R | R | R | R | R | R | R |

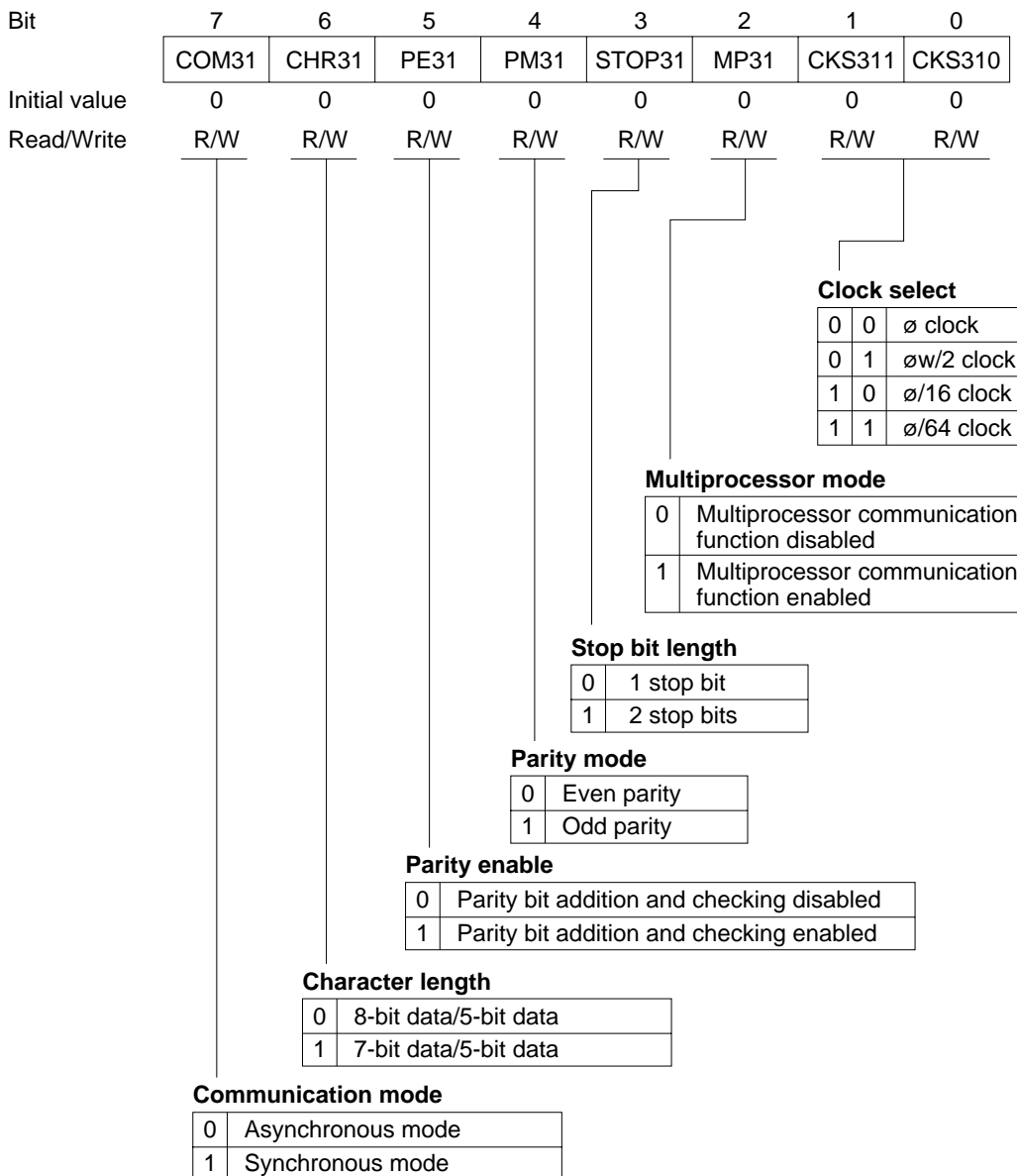

| Bit | 7 | 6 | 5 | 4 | 3 | 2 | 1 | 0 |
|---------------|--------|--------|--------|--------|--------|--------|--------|--------|
| | BRR317 | BRR316 | BRR315 | BRR314 | BRR313 | BRR312 | BRR311 | BRR310 |
| Initial value | 1 | 1 | 1 | 1 | 1 | 1 | 1 | 1 |
| Read/Write | R/W | R/W | R/W | R/W | R/W | R/W | R/W | R/W |

| | | | | | | | | |
|---------------|-------|-------|------|------|--------|--------|--------|--------|
| Bit | 7 | 6 | 5 | 4 | 3 | 2 | 1 | 0 |
| | TIE31 | RIE31 | TE31 | RE31 | MPIE31 | TEIE31 | CKE311 | CKE310 |
| Initial value | 0 | 0 | 0 | 0 | 0 | 0 | 0 | 0 |
| Read/Write | R/W | R/W | R/W | R/W | R/W | R/W | R/W | R/W |

Clock enable

| Bit 1 | Bit 0 | Description | | |
|-------|-------|--------------|--|---------------------|
| 0 | 0 | Asynchronous | Internal clock | I/O port |
| | | Synchronous | Internal clock | Serial clock output |
| 0 | 1 | Asynchronous | Internal clock | Clock output |
| | | Synchronous | Reserved (Do not specify this combination) | |
| 1 | 0 | Asynchronous | External clock | Clock input |
| | | Synchronous | External clock | Serial clock input |
| 1 | 1 | Asynchronous | Reserved (Do not specify this combination) | |
| | | Synchronous | Reserved (Do not specify this combination) | |

Transmit end interrupt enable

| | |
|---|---|
| 0 | Transmit end interrupt request (TEI) disabled |
| 1 | Transmit end interrupt request (TEI) enabled |

Multiprocessor interrupt enable

| | |
|---|--|
| 0 | Multiprocessor interrupt request disabled (normal receive operation) [Clearing conditions] When data is received in which the multiprocessor bit is set to 1 |
| 1 | Multiprocessor interrupt request enabled The receive interrupt request (RXI), receive error interrupt request (ERI), and setting of the RDRF, FER, and OER flags in the serial status register (SSR), are disabled until data with the multiprocessor bit set to 1 is received. |

Receive enable

| | |
|---|---|
| 0 | Receive operation disabled (RXD pin is I/O port) |
| 1 | Receive operation enabled (RXD pin is receive data pin) |

Transmit enable

| | |
|---|--|
| 0 | Transmit operation disabled (TXD pin is transmit data pin) |
| 1 | Transmit operation enabled (TXD pin is transmit data pin) |

Receive interrupt enable

| | |
|---|--|
| 0 | Receive data full interrupt request (RXI) and receive error interrupt request (ERI) disabled |
| 1 | Receive data full interrupt request (RXI) and receive error interrupt request (ERI) enabled |

Transmit interrupt enable

| | |
|---|--|
| 0 | Transmit data empty interrupt request (TXI) disabled |
| 1 | Transmit data empty interrupt request (TXI) enabled |

| | | | | | | | | |
|---------------|--------|--------|--------|--------|--------|--------|--------|--------|
| Bit | 7 | 6 | 5 | 4 | 3 | 2 | 1 | 0 |
| | TDR317 | TDR316 | TDR315 | TDR314 | TDR313 | TDR312 | TDR311 | TDR310 |
| Initial value | 1 | 1 | 1 | 1 | 1 | 1 | 1 | 1 |
| Read/Write | R/W | R/W | R/W | R/W | R/W | R/W | R/W | R/W |

Data for transfer to TSR

| Bit | 7 | 6 | 5 | 4 | 3 | 2 | 1 | 0 |
|---------------|--------|--------|--------|--------|--------|--------|--------|--------|
| | TDRE31 | RDRF31 | OER31 | FER31 | PER31 | TEND31 | MPBR31 | MPBT31 |
| Initial value | 1 | 0 | 0 | 0 | 0 | 1 | 0 | 0 |
| Read/Write | R/(W)* | R/(W)* | R/(W)* | R/(W)* | R/(W)* | R | R | R/W |

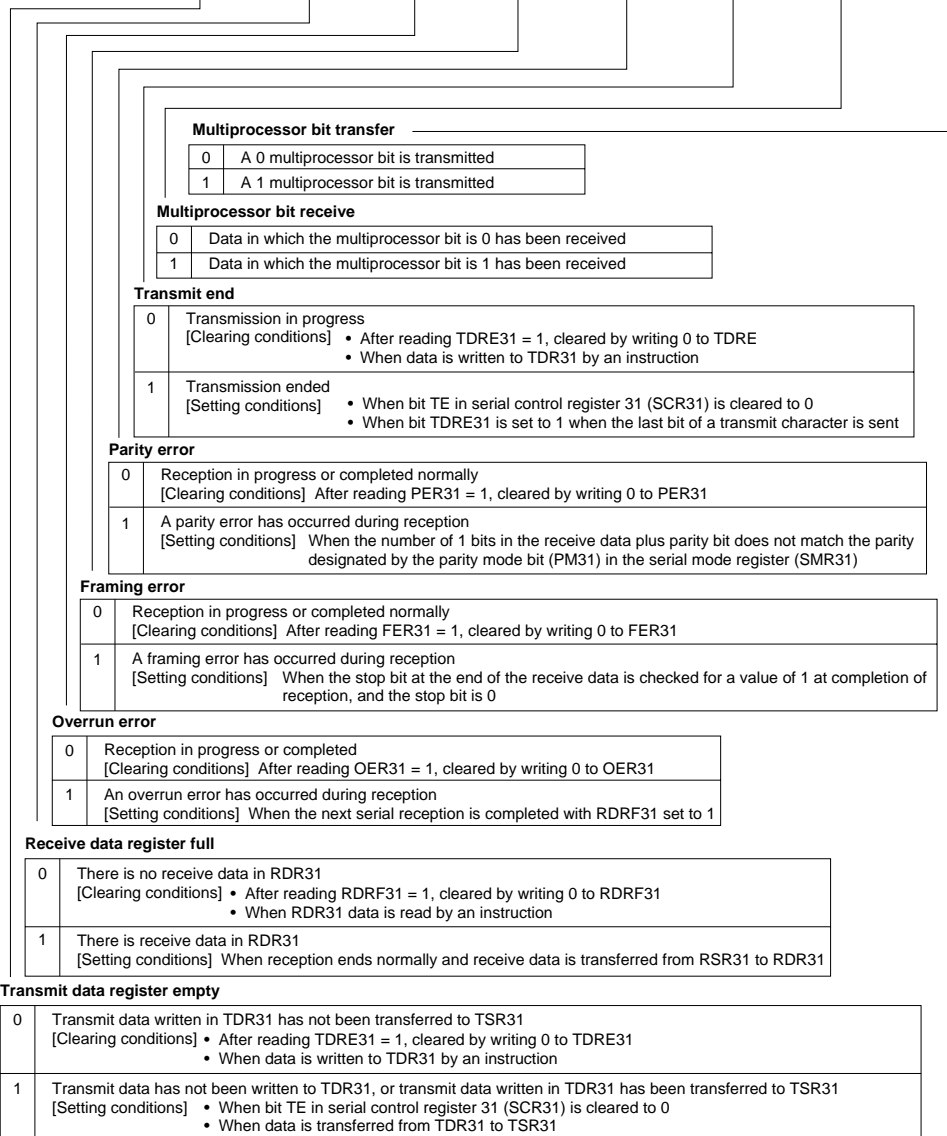

Note: * Only a write of 0 for flag clearing is possible.

| Bit | 7 | 6 | 5 | 4 | 3 | 2 | 1 | 0 |
|---------------|--------|--------|--------|--------|--------|--------|--------|--------|
| | RDR317 | RDR316 | RDR315 | RDR314 | RDR313 | RDR312 | RDR311 | RDR310 |
| Initial value | 0 | 0 | 0 | 0 | 0 | 0 | 0 | 0 |
| Read/Write | R | R | R | R | R | R | R | R |

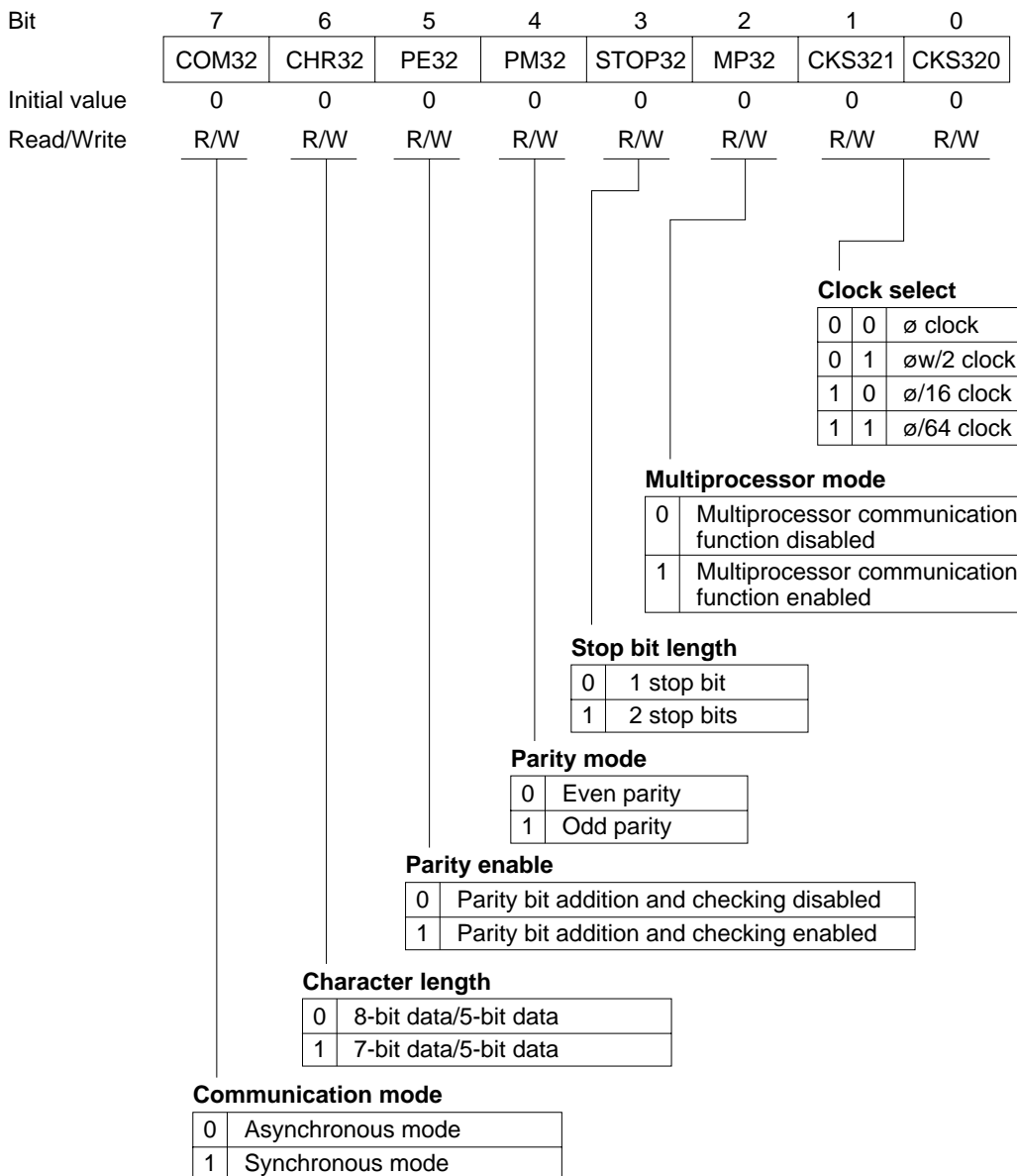

| Bit | 7 | 6 | 5 | 4 | 3 | 2 | 1 | 0 |
|---------------|--------|--------|--------|--------|--------|--------|--------|---------|
| | BRR327 | BRR326 | BRR325 | BRR324 | BRR323 | BRR322 | BRR321 | BRR3120 |
| Initial value | 1 | 1 | 1 | 1 | 1 | 1 | 1 | 1 |
| Read/Write | R/W | R/W | R/W | R/W | R/W | R/W | R/W | R/W |

| | | | | | | | | |
|---------------|-------|-------|------|------|--------|--------|--------|--------|
| Bit | 7 | 6 | 5 | 4 | 3 | 2 | 1 | 0 |
| | TIE32 | RIE32 | TE32 | RE32 | MPIE32 | TEIE32 | CKE321 | CKE320 |
| Initial value | 0 | 0 | 0 | 0 | 0 | 0 | 0 | 0 |
| Read/Write | R/W | R/W | R/W | R/W | R/W | R/W | R/W | R/W |

Clock enable

| Bit 1 | Bit 0 | Description | | |
|-------|-------|--------------|--|---------------------|
| 0 | 0 | Asynchronous | Internal clock | I/O port |
| | | Synchronous | Internal clock | Serial clock output |
| 0 | 1 | Asynchronous | Internal clock | Clock output |
| | | Synchronous | Reserved (Do not specify this combination) | |
| 1 | 0 | Asynchronous | External clock | Clock input |
| | | Synchronous | External clock | Serial clock input |
| 1 | 1 | Asynchronous | Reserved (Do not specify this combination) | |
| | | Synchronous | Reserved (Do not specify this combination) | |

Transmit end interrupt enable

| | |
|---|---|
| 0 | Transmit end interrupt request (TEI) disabled |
| 1 | Transmit end interrupt request (TEI) enabled |

Multiprocessor interrupt enable

| | |
|---|--|
| 0 | Multiprocessor interrupt request disabled (normal receive operation) [Clearing conditions] When data is received in which the multiprocessor bit is set to 1 |
| 1 | Multiprocessor interrupt request enabled The receive interrupt request (RXI), receive error interrupt request (ERI), and setting of the RDRF, FER, and OER flags in the serial status register (SSR), are disabled until data with the multiprocessor bit set to 1 is received. |

Receive enable

| | |
|---|---|
| 0 | Receive operation disabled (RXD pin is I/O port) |
| 1 | Receive operation enabled (RXD pin is receive data pin) |

Transmit enable

| | |
|---|--|
| 0 | Transmit operation disabled (TXD pin is transmit data pin) |
| 1 | Transmit operation enabled (TXD pin is transmit data pin) |

Receive interrupt enable

| | |
|---|--|
| 0 | Receive data full interrupt request (RXI) and receive error interrupt request (ERI) disabled |
| 1 | Receive data full interrupt request (RXI) and receive error interrupt request (ERI) enabled |

Transmit interrupt enable

| | |
|---|--|
| 0 | Transmit data empty interrupt request (TXI) disabled |
| 1 | Transmit data empty interrupt request (TXI) enabled |

| Bit | 7 | 6 | 5 | 4 | 3 | 2 | 1 | 0 |
|---------------|--------|--------|--------|--------|--------|--------|--------|--------|
| | TDR327 | TDR326 | TDR325 | TDR324 | TDR323 | TDR322 | TDR321 | TDR320 |
| Initial value | 1 | 1 | 1 | 1 | 1 | 1 | 1 | 1 |
| Read/Write | R/W | R/W | R/W | R/W | R/W | R/W | R/W | R/W |

Data for transfer to TSR

| Bit | 7 | 6 | 5 | 4 | 3 | 2 | 1 | 0 |
|---------------|--------|--------|--------|--------|--------|--------|--------|--------|
| | TDRE32 | RDRF32 | OER32 | FER32 | PER32 | TEND32 | MPBR32 | MPBT32 |
| Initial value | 1 | 0 | 0 | 0 | 0 | 1 | 0 | 0 |
| Read/Write | R/(W)* | R/(W)* | R/(W)* | R/(W)* | R/(W)* | R | R | R/W |

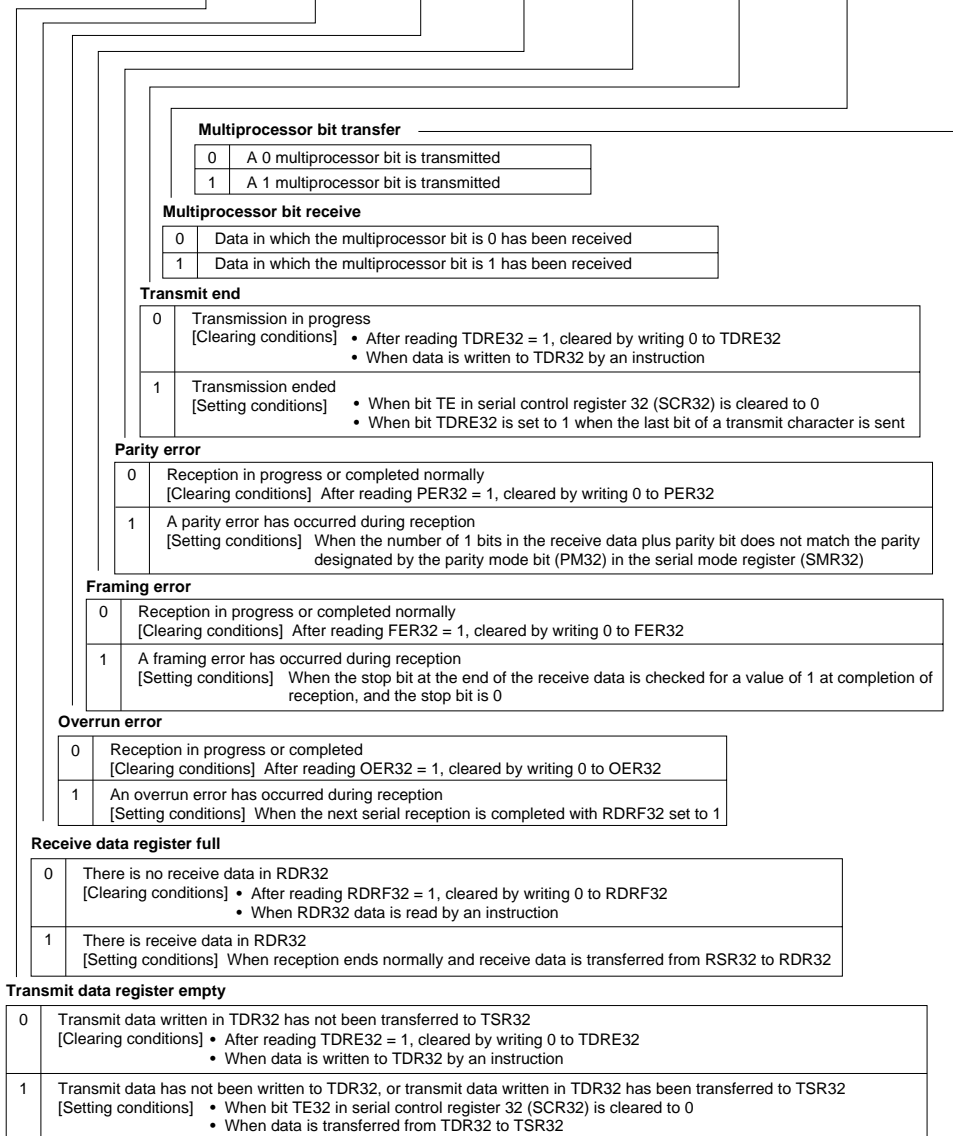

Note: * Only a write of 0 for flag clearing is possible.

| | | | | | | | | |
|---------------|--------|--------|--------|--------|--------|--------|--------|--------|
| Bit | 7 | 6 | 5 | 4 | 3 | 2 | 1 | 0 |
| | RDR327 | RDR326 | RDR325 | RDR324 | RDR323 | RDR322 | RDR321 | RDR320 |
| Initial value | 0 | 0 | 0 | 0 | 0 | 0 | 0 | 0 |
| Read/Write | R | R | R | R | R | R | R | R |

TMA—Timer mode register A

H'B0

Timer A

| | | | | | | | | |
|---------------|------|------|------|---|------|------|------|------|
| Bit | 7 | 6 | 5 | 4 | 3 | 2 | 1 | 0 |
| | TMA7 | TMA6 | TMA5 | — | TMA3 | TMA2 | TMA1 | TMA0 |
| Initial value | 0 | 0 | 0 | 1 | 0 | 0 | 0 | 0 |
| Read/Write | R/W | R/W | R/W | — | R/W | R/W | R/W | R/W |

Clock output select

| | | | |
|---|---|---|---------------------------|
| 0 | 0 | 0 | $\emptyset/32$ |
| | | 1 | $\emptyset/16$ |
| | 1 | 0 | $\emptyset/8$ |
| | | 1 | $\emptyset/4$ |
| 1 | 0 | 0 | $\emptyset_{\text{W}}/32$ |
| | | 1 | $\emptyset_{\text{W}}/16$ |
| | 1 | 0 | $\emptyset_{\text{W}}/8$ |
| | | 1 | $\emptyset_{\text{W}}/4$ |

Internal clock select

| TMA3 | TMA2 | TMA1 | TMA0 | Prescaler and Divider Ratio or Overflow Period | Function |
|------|------|------|------|--|-----------------------------------|
| 0 | 0 | 0 | 0 | PSS $\emptyset/8192$ | Interval timer |
| | | | 1 | PSS $\emptyset/4096$ | |
| | | 1 | 0 | PSS $\emptyset/2048$ | |
| | | | 1 | PSS $\emptyset/512$ | |
| | 1 | 0 | 0 | PSS $\emptyset/256$ | |
| | | | 1 | PSS $\emptyset/128$ | |
| | | 1 | 0 | PSS $\emptyset/32$ | |
| | | | 1 | PSS $\emptyset/8$ | |
| 1 | 0 | 0 | 0 | PSW 1 s | Time base (when using 32.768 kHz) |
| | | | 1 | PSW 0.5 s | |
| | | 1 | 0 | PSW 0.25 s | |
| | | | 1 | PSW 0.03125 s | |
| | 1 | 0 | 0 | PSW and TCA are reset | |
| | | | 1 | | |
| | | 1 | 0 | | |

| Bit | 7 | 6 | 5 | 4 | 3 | 2 | 1 | 0 |
|---------------|------|------|------|------|------|------|------|------|
| | TCA7 | TCA6 | TCA5 | TCA4 | TCA3 | TCA2 | TCA1 | TCA0 |
| Initial value | 0 | 0 | 0 | 0 | 0 | 0 | 0 | 0 |
| Read/Write | R | R | R | R | R | R | R | R |

|
Count value

| Bit | 7 | 6 | 5 | 4 | 3 | 2 | 1 | 0 |
|---------------|------|--------|------|--------|------|--------|------|--------|
| | B6WI | TCWE | B4WI | TCSRWE | B2WI | WDON | B0WI | WRST |
| Initial value | 1 | 0 | 1 | 0 | 1 | 0 | 1 | 0 |
| Read/Write | R | R/(W)* | R | R/(W)* | R | R/(W)* | R | R/(W)* |

Watchdog timer reset

| | |
|---|--|
| 0 | [Clearing conditions] • Reset by $\overline{\text{RES}}$ pin • When TCSRWE = 1, and 0 is written in both B0WI and WRST |
| 1 | [Setting condition] When TCW overflows and a reset signal is generated |

Bit 0 write inhibit

| | |
|---|--------------------------|
| 0 | Bit 0 is write-enabled |
| 1 | Bit 0 is write-protected |

Watchdog timer on

| | |
|---|--------------------------------------|
| 0 | Watchdog timer operation is disabled |
| 1 | Watchdog timer operation is enabled |

Bit 2 write inhibit

| | |
|---|--------------------------|
| 0 | Bit 2 is write-enabled |
| 1 | Bit 2 is write-protected |

Timer control/status register W write enable

| | |
|---|--|
| 0 | Data cannot be written to bits 2 and 0 |
| 1 | Data can be written to bits 2 and 0 |

Bit 4 write inhibit

| | |
|---|--------------------------|
| 0 | Bit 4 is write-enabled |
| 1 | Bit 4 is write-protected |

Timer counter W write enable

| | |
|---|-------------------------------|
| 0 | Data cannot be written to TCW |
| 1 | Data can be written to TCW |

Bit 6 write inhibit

| | |
|---|--------------------------|
| 0 | Bit 6 is write-enabled |
| 1 | Bit 6 is write-protected |

Note: * Write is permitted only under certain conditions.

TCW—Timer counter W

H'B3

Watchdog timer

| Bit | 7 | 6 | 5 | 4 | 3 | 2 | 1 | 0 |
|---------------|------|------|------|------|------|------|------|------|
| | TCW7 | TCW6 | TCW5 | TCW4 | TCW3 | TCW2 | TCW1 | TCW0 |
| Initial value | 0 | 0 | 0 | 0 | 0 | 0 | 0 | 0 |
| Read/Write | R/W | R/W | R/W | R/W | R/W | R/W | R/W | R/W |

Count value

TMC—Timer mode register C

H'B4

Timer C

| Bit | 7 | 6 | 5 | 4 | 3 | 2 | 1 | 0 |
|---------------|------|------|------|---|---|------|------|------|
| | TMC7 | TMC6 | TMC5 | — | — | TMC2 | TMC1 | TMC0 |
| Initial value | 0 | 0 | 0 | 1 | 1 | 0 | 0 | 0 |
| Read/Write | R/W | R/W | R/W | — | — | R/W | R/W | R/W |

Clock select

| | | | |
|---|---|---|---|
| 0 | 0 | 0 | Internal clock: $\phi/8192$ |
| 0 | 0 | 1 | Internal clock: $\phi/2048$ |
| 0 | 1 | 0 | Internal clock: $\phi/512$ |
| 0 | 1 | 1 | Internal clock: $\phi/64$ |
| 1 | 0 | 0 | Internal clock: $\phi/16$ |
| 1 | 0 | 1 | Internal clock: $\phi/4$ |
| 1 | 1 | 0 | Internal clock: $\phi w/4$ |
| 1 | 1 | 1 | External event (TMIC): Counting on rising or falling edge |

Counter up/down control

| | | |
|---|---|--|
| 0 | 0 | TCC is an up-counter |
| 0 | 1 | TCC is a down-counter |
| 1 | * | Hardware control of TCC up/down operation by UD pin input UD pin input high: Down-counter UD pin input low: Up-counter |

Auto-reload function select

| | |
|---|----------------------------------|
| 0 | Interval timer function selected |
| 1 | Auto-reload function selected |

* : Don't care

TCC—Timer counter C**H'B5****Timer C**

| Bit | 7 | 6 | 5 | 4 | 3 | 2 | 1 | 0 |
|---------------|------|------|------|------|------|------|------|------|
| | TCC7 | TCC6 | TCC5 | TCC4 | TCC3 | TCC2 | TCC1 | TCC0 |
| Initial value | 0 | 0 | 0 | 0 | 0 | 0 | 0 | 0 |
| Read/Write | R | R | R | R | R | R | R | R |

|
Count value

TLC—Timer load register C**H'B5****Timer C**

| Bit | 7 | 6 | 5 | 4 | 3 | 2 | 1 | 0 |
|---------------|------|------|------|------|------|------|------|------|
| | TLC7 | TLC6 | TLC5 | TLC4 | TLC3 | TLC2 | TLC1 | TLC0 |
| Initial value | 0 | 0 | 0 | 0 | 0 | 0 | 0 | 0 |
| Read/Write | R/W | R/W | R/W | R/W | R/W | R/W | R/W | R/W |

|
Reload value

| | | | | | | | | |
|---------------|------|-------|-------|-------|------|-------|-------|-------|
| Bit | 7 | 6 | 5 | 4 | 3 | 2 | 1 | 0 |
| | TOLH | CKSH2 | CKSH1 | CKSH0 | TOLL | CKSL2 | CKSL1 | CKSL0 |
| Initial value | 0 | 0 | 0 | 0 | 0 | 0 | 0 | 0 |
| Read/Write | W | W | W | W | W | W | W | W |

Clock select L

| | | | |
|---|---|---|---|
| 0 | * | * | Counting on external event (TMIF) rising/falling edge |
| 1 | 0 | 0 | Internal clock $\phi/32$ |
| 1 | 0 | 1 | Internal clock $\phi/16$ |
| 1 | 1 | 0 | Internal clock $\phi/4$ |
| 1 | 1 | 1 | Internal clock $\phi_w/4$ |

Toggle output level L

| | |
|---|------------|
| 0 | Low level |
| 1 | High level |

Clock select H

| | | | |
|---|---|---|---|
| 0 | * | * | 16-bit mode, counting on TCFL overflow signal |
| 1 | 0 | 0 | Internal clock $\phi/32$ |
| 1 | 0 | 1 | Internal clock $\phi/16$ |
| 1 | 1 | 0 | Internal clock $\phi/4$ |
| 1 | 1 | 1 | Internal clock $\phi_w/4$ |

Toggle output level H

| | |
|---|------------|
| 0 | Low level |
| 1 | High level |

*: Don't care

| Bit | 7 | 6 | 5 | 4 | 3 | 2 | 1 | 0 |
|---------------|--------|--------|-------|-------|--------|------|-------|-------|
| | OVFH | CMFH | OVIEH | CCLRH | OVFL | CMFL | OVIEL | CCLRL |
| Initial value | 0 | 0 | 0 | 0 | 0 | 0 | 0 | 0 |
| Read/Write | R/(W)* | R/(W)* | R/(W) | R/(W) | R/(W)* | R/W* | R/W | R/W |

Counter clear L

| | |
|---|--|
| 0 | TCFL clearing by compare match is disabled |
| 1 | TCFL clearing by compare match is enabled |

Timer overflow interrupt enable L

| | |
|---|---|
| 0 | TCFL overflow interrupt request is disabled |
| 1 | TCFL overflow interrupt request is enabled |

Compare match flag L

| | |
|---|--|
| 0 | Clearing conditions: After reading CMFL = 1, cleared by writing 0 to CMFL |
| 1 | Setting conditions: Set when the TCFL value matches the OCRFL value |

Timer overflow flag L

| | |
|---|--|
| 0 | Clearing conditions: After reading OVFL = 1, cleared by writing 0 to OVFL |
| 1 | Setting conditions: Set when TCFL overflows from H'FF to H'00 |

Counter clear H

| | |
|---|--|
| 0 | 16-bit mode: TCF clearing by compare match is disabled 8-bit mode: TCFH clearing by compare match is disabled |
| 1 | 16-bit mode: TCF clearing by compare match is enabled 8-bit mode: TCFH clearing by compare match is enabled |

Timer overflow interrupt enable H

| | |
|---|---|
| 0 | TCFH overflow interrupt request is disabled |
| 1 | TCFH overflow interrupt request is enabled |

Compare match flag H

| | |
|---|--|
| 0 | Clearing conditions: After reading CMFH = 1, cleared by writing 0 to CMFH |
| 1 | Setting conditions: Set when the TCFH value matches the OCRFH value |

Timer overflow flag H

| | |
|---|--|
| 0 | Clearing conditions: After reading OVFH = 1, cleared by writing 0 to OVFH |
| 1 | Setting conditions: Set when TCFH overflows from H'FF to H'00 |

Note: * Bits 7, 6, 3, and 2 can only be written with 0, for flag clearing.

TCFH—8-bit timer counter FH**H'B8****Timer F**

| | | | | | | | | |
|---------------|-------|-------|-------|-------|-------|-------|-------|-------|
| Bit | 7 | 6 | 5 | 4 | 3 | 2 | 1 | 0 |
| | TCFH7 | TCFH6 | TCFH5 | TCFH4 | TCFH3 | TCFH2 | TCFH1 | TCFH0 |
| Initial value | 0 | 0 | 0 | 0 | 0 | 0 | 0 | 0 |
| Read/Write | R/W | R/W | R/W | R/W | R/W | R/W | R/W | R/W |

Count value

TCFL—8-bit timer counter FL**H'B9****Timer F**

| | | | | | | | | |
|---------------|-------|-------|-------|-------|-------|-------|-------|-------|
| Bit | 7 | 6 | 5 | 4 | 3 | 2 | 1 | 0 |
| | TCFL7 | TCFL6 | TCFL5 | TCFL4 | TCFL3 | TCFL2 | TCFL1 | TCFL0 |
| Initial value | 0 | 0 | 0 | 0 | 0 | 0 | 0 | 0 |
| Read/Write | R/W | R/W | R/W | R/W | R/W | R/W | R/W | R/W |

Count value

OCRFH—Output compare register FH**H'BA****Timer F**

| | | | | | | | | |
|---------------|--------|--------|--------|--------|--------|--------|--------|--------|
| Bit | 7 | 6 | 5 | 4 | 3 | 2 | 1 | 0 |
| | OCRFH7 | OCRFH6 | OCRFH5 | OCRFH4 | OCRFH3 | OCRFH2 | OCRFH1 | OCRFH0 |
| Initial value | 1 | 1 | 1 | 1 | 1 | 1 | 1 | 1 |
| Read/Write | R/W | R/W | R/W | R/W | R/W | R/W | R/W | R/W |

OCRFL—Output compare register FL**H'BB****Timer F**

| | | | | | | | | |
|---------------|--------|--------|--------|--------|--------|--------|--------|--------|
| Bit | 7 | 6 | 5 | 4 | 3 | 2 | 1 | 0 |
| | OCRFL7 | OCRFL6 | OCRFL5 | OCRFL4 | OCRFL3 | OCRFL2 | OCRFL1 | OCRFL0 |
| Initial value | 1 | 1 | 1 | 1 | 1 | 1 | 1 | 1 |
| Read/Write | R/W | R/W | R/W | R/W | R/W | R/W | R/W | R/W |

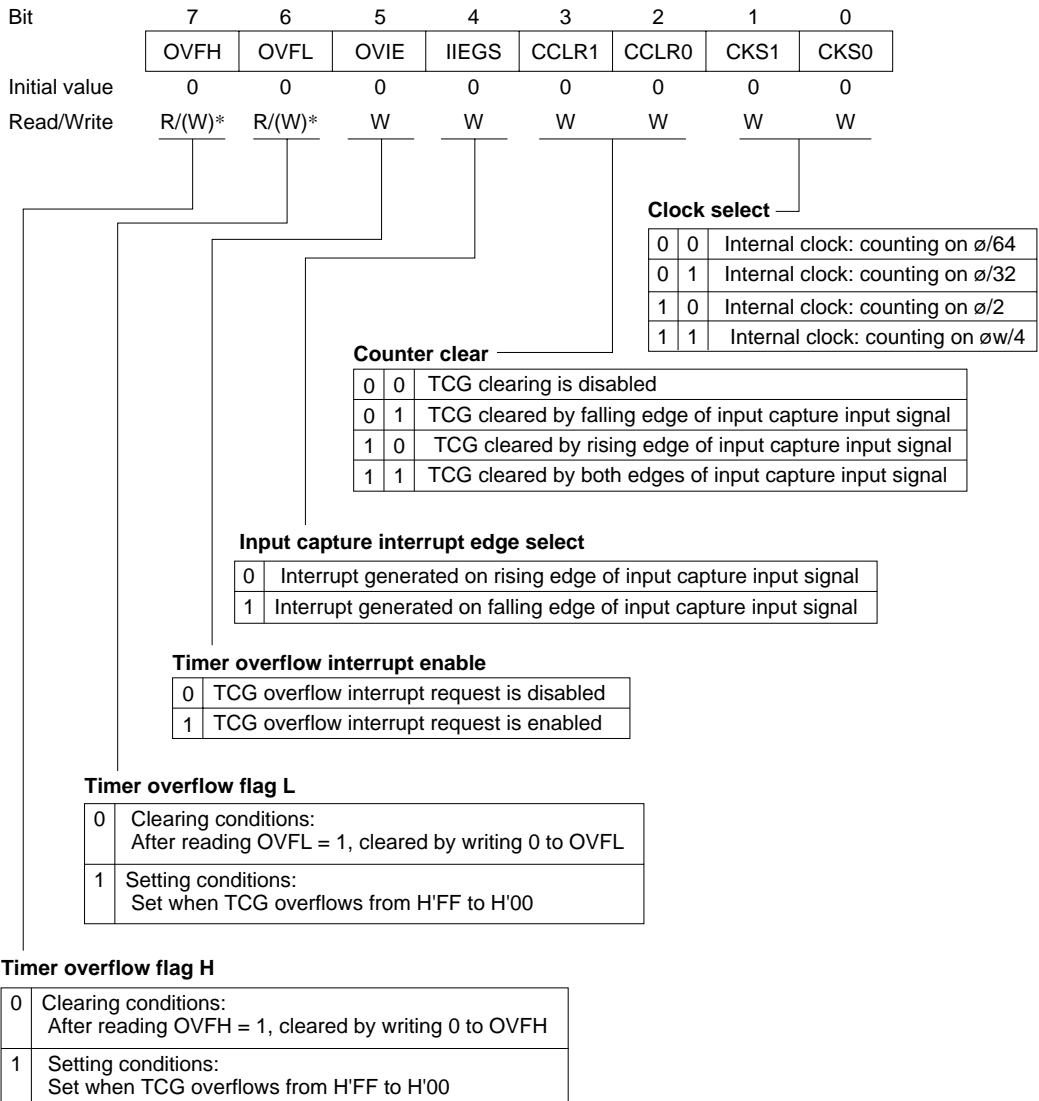

Note: * Bits 7 and 6 can only be written with 0, for flag clearing.

ICRGF—Input capture register GF**H'BD****Timer G**

| Bit | 7 | 6 | 5 | 4 | 3 | 2 | 1 | 0 |
|---------------|--------|--------|--------|--------|--------|--------|--------|--------|
| | ICRGF7 | ICRGF6 | ICRGF5 | ICRGF4 | ICRGF3 | ICRGF2 | ICRGF1 | ICRGF0 |
| Initial value | 0 | 0 | 0 | 0 | 0 | 0 | 0 | 0 |
| Read/Write | R | R | R | R | R | R | R | R |

ICRGR—Input capture register GR**H'BE****Timer G**

| Bit | 7 | 6 | 5 | 4 | 3 | 2 | 1 | 0 |
|---------------|--------|--------|--------|--------|--------|--------|--------|--------|
| | ICRGR7 | ICRGR6 | ICRGR5 | ICRGR4 | ICRGR3 | ICRGR2 | ICRGR1 | ICRGR0 |
| Initial value | 0 | 0 | 0 | 0 | 0 | 0 | 0 | 0 |
| Read/Write | R | R | R | R | R | R | R | R |

| | | | | | | | | |
|---------------|------|------|-----|-----|------|------|------|------|
| Bit | 7 | 6 | 5 | 4 | 3 | 2 | 1 | 0 |
| | DTS1 | DTS0 | CMX | SGX | SGS3 | SGS2 | SGS1 | SGS0 |
| Initial value | 0 | 0 | 0 | 0 | 0 | 0 | 0 | 0 |
| Read/Write | R/W | R/W | R/W | R/W | R/W | R/W | R/W | R/W |

Clock enable

| Bit 4 | Bit 3 | Bit 2 | Bit 1 | Bit 0 | Function of Pins SEG ₃₂ to SEG ₁ | | | | | | | | Notes |
|-------|-------|-------|-------|-------|--|--|--|--|--|---------------------------------------|--------------------------------------|--------------------------------------|-----------------|
| SGX | SGS3 | SGS2 | SGS1 | SGS0 | SEG ₃₂ to SEG ₂₉ | SEG ₂₈ to SEG ₂₅ | SEG ₂₄ to SEG ₂₁ | SEG ₂₀ to SEG ₁₇ | SEG ₁₆ to SEG ₁₃ | SEG ₁₂ to SEG ₉ | SEG ₈ to SEG ₅ | SEG ₄ to SEG ₁ | |
| 0 | 0 | 0 | 0 | 0 | Port | Port | Port | Port | Port | Port | Port | Port | (Initial value) |
| | 0 | 0 | 0 | 1 | Port | Port | Port | Port | Port | Port | Port | Port | |
| | 0 | 0 | 1 | * | SEG | SEG | Port | Port | Port | Port | Port | Port | |
| | 0 | 1 | 0 | * | SEG | SEG | SEG | SEG | Port | Port | Port | Port | |
| | 0 | 1 | 1 | * | SEG | SEG | SEG | SEG | SEG | SEG | Port | Port | |
| | 1 | * | * | * | SEG | SEG | SEG | SEG | SEG | SEG | SEG | SEG | SEG |
| 1 | 0 | 0 | 0 | 0 | Port* | Port | Port | Port | Port | Port | Port | Port | |
| | * | * | * | * | Use prohibited | | | | | | | | |

Note: * SEG32 to SEG29 are external expansion pins.

*: Don't care

| Bit 4 | Description |
|-------|---|
| SGX | |
| 0 | Pins SEG ₃₂ to SEG ₂₉ * (Initial value) |
| 1 | Pins CL ₁ , CL ₂ , DO, M |

Note: * These pins function as ports when the setting of SGS3 to SGS0 is 0000 or 0001.

Duty select, common function select

| Bit 7 | Bit 6 | Bit 5 | Duty Cycle | Common Drivers | Notes |
|-------|-------|-------|------------|--------------------------------------|---|
| DTS1 | DTS0 | CMX | | | |
| 0 | 0 | 0 | Static | COM ₁ | |
| | | 1 | | COM ₄ to COM ₁ | COM ₄ to COM ₂ output the same waveform as COM ₁ |
| 0 | 1 | 0 | 1/2 duty | COM ₂ to COM ₁ | |
| | | 1 | | COM ₄ to COM ₁ | COM ₄ outputs the same waveform as COM ₃ and COM ₂ outputs the same waveform as COM ₁ |
| 1 | 0 | 0 | 1/3 duty | COM ₃ to COM ₁ | |
| | | 1 | | COM ₄ to COM ₁ | COM ₄ outputs a non-selected waveform |
| 1 | 1 | 0 | 1/4 duty | COM ₄ to COM ₁ | — |
| | | 1 | | | |

| | | | | | | | | |
|---------------|---|-----|-----|------|------|------|------|------|
| Bit | 7 | 6 | 5 | 4 | 3 | 2 | 1 | 0 |
| | — | PSW | ACT | DISP | CKS3 | CKS2 | CKS1 | CKS0 |
| Initial value | 1 | 0 | 0 | 0 | 0 | 0 | 0 | 0 |
| Read/Write | — | R/W | R/W | R/W | R/W | R/W | R/W | R/W |

Frame frequency select

| Bit 3 | Bit 2 | Bit 1 | Bit 1 | Operating Clock |
|-------|-------|-------|-------|-----------------|
| CKS3 | CKS2 | CKS1 | CKS0 | |
| 0 | * | 0 | 0 | ϕw |
| 0 | * | 0 | 1 | ϕw |
| 0 | * | 1 | * | $\phi w/2$ |
| 1 | 0 | 0 | 0 | $\phi/2$ |
| 1 | 0 | 0 | 1 | $\phi/4$ |
| 1 | 0 | 1 | 0 | $\phi/8$ |
| 1 | 0 | 1 | 1 | $\phi/16$ |
| 1 | 1 | 0 | 0 | $\phi/32$ |
| 1 | 1 | 0 | 1 | $\phi/64$ |
| 1 | 1 | 1 | 0 | $\phi/128$ |
| 1 | 1 | 1 | 1 | $\phi/256$ |

* : Don't care

Display data control

| | |
|---|---------------------------|
| 0 | Blank data is displayed |
| 1 | LCD RAM data is displayed |

Display function activate

| | |
|---|--|
| 0 | LCD controller/driver operation halted |
| 1 | LCD controller/driver operates |

LCD drive power supply on/off control

| | |
|---|----------------------------|
| 0 | LCD drive power supply off |
| 1 | LCD drive power supply on |

| | | | | | | | | |
|---------------|-------|---|---|------|------|------|------|------|
| Bit | 7 | 6 | 5 | 4 | 3 | 2 | 1 | 0 |
| | LCDAB | — | — | SUPS | CDS3 | CDS2 | CDS1 | CDS0 |
| Initial value | 0 | 1 | 1 | 0 | 0 | 0 | 0 | 0 |
| Read/Write | R/W | — | — | R/W | R/W | R/W | R/W | R/W |

Charge/discharge pulse duty cycle select

| Bit 3 | Bit 2 | Bit 1 | Bit 1 | Duty Cycle |
|-------|-------|-------|-------|------------|
| CDS3 | CDS2 | CDS1 | CDS0 | |
| 0 | 0 | 0 | 0 | 1 |
| 0 | 0 | 0 | 1 | 1/8 |
| 0 | 0 | 1 | 0 | 2/8 |
| 0 | 0 | 1 | 1 | 3/8 |
| 0 | 1 | 0 | 0 | 4/8 |
| 0 | 1 | 0 | 1 | 5/8 |
| 0 | 1 | 1 | 0 | 6/8 |
| 0 | 1 | 1 | 1 | 0 |
| 1 | 0 | * | * | 1/16 |
| 1 | 1 | * | * | 1/32 |

* : Don't care

5 V regulator control

| | |
|---|------------------------|
| 0 | 5 V regulator halted |
| 1 | 5 V regulator operates |

Applies to the H8/3867 Series

A waveform/B waveform switching control

| | |
|---|------------------------|
| 0 | Drive using A waveform |
| 1 | Drive using B waveform |

| | | | | | | | | |
|---------------|-----|------|---|---|-----|-----|-----|-----|
| Bit | 7 | 6 | 5 | 4 | 3 | 2 | 1 | 0 |
| | CKS | TRGE | — | — | CH3 | CH2 | CH1 | CH0 |
| Initial value | 0 | 0 | 1 | 1 | 0 | 0 | 0 | 0 |
| Read/Write | R/W | R/W | — | — | R/W | R/W | R/W | R/W |

Channel select

| Bit 3 | Bit 2 | Bit 1 | Bit 0 | |
|-------|-------|-------|-----------------|----------------------|
| CH3 | CH2 | CH1 | CH0 | Analog Input Channel |
| 0 | 0 | * | * | No channel selected |
| | | | | 1 |
| | 1 | 0 | AN ₂ | |
| | | 1 | 1 | AN ₃ |
| 1 | 0 | | 0 | 0 |
| | | 1 | | AN ₅ |
| | 1 | 0 | 0 | AN ₆ |
| | | | 1 | AN ₇ |

* : Don't care

External trigger select

| | |
|---|--|
| 0 | Disables start of A/D conversion by external trigger |
| 1 | Enables start of A/D conversion by rising or falling edge of external trigger at pin ADTRG |

Clock select

| Bit 7 | Conversion Period | Conversion Time | |
|-------|-------------------|-----------------|----------------|
| CKS | | $\phi = 1$ MHz | $\phi = 2$ MHz |
| 0 | $62/\phi$ | 62 μ s | 31 μ s |
| 1 | $31/\phi$ | 31 μ s | 15.5 μ s* |

Note: * Operation is not guaranteed with a conversion time of less than 15.5 μ s
 Select a setting that gives a conversion time of at least 15.5 μ s.

ADRRH

| Bit | 7 | 6 | 5 | 4 | 3 | 2 | 1 | 0 |
|---------------|-----------|-----------|-----------|-----------|-----------|-----------|-----------|-----------|
| | ADR9 | ADR8 | ADR7 | ADR6 | ADR5 | ADR4 | ADR3 | ADR2 |
| Initial value | Not fixed | Not fixed | Not fixed | Not fixed | Not fixed | Not fixed | Not fixed | Not fixed |
| Read/Write | R/(W) | R/(W) | R/(W) | R/(W) | R/(W) | R/(W) | R/(W) | R/(W) |

A/D conversion result

ADRRL

| Bit | 7 | 6 | 5 | 4 | 3 | 2 | 1 | 0 |
|---------------|-----------|-----------|---|---|---|---|---|---|
| | ADR1 | ADR0 | — | — | — | — | — | — |
| Initial value | Not fixed | Not fixed | — | — | — | — | — | — |
| Read/Write | R | R | — | — | — | — | — | — |

A/D conversion result

ADSR—A/D start register

| Bit | 7 | 6 | 5 | 4 | 3 | 2 | 1 | 0 |
|---------------|------|---|---|---|---|---|---|---|
| | ADSF | — | — | — | — | — | — | — |
| Initial value | 0 | 1 | 1 | 1 | 1 | 1 | 1 | 1 |
| Read/Write | R/W | — | — | — | — | — | — | — |

A/D status flag

| | | |
|---|-------|--|
| 0 | Read | Indicates completion of A/D conversion |
| | Write | Stops A/D conversion |
| 1 | Read | Indicates A/D conversion in progress |
| | Write | Starts A/D conversion |

| | | | | | | | | |
|---------------|-------|-------|-------|-------|-------|-------|-------|-------|
| Bit | 7 | 6 | 5 | 4 | 3 | 2 | 1 | 0 |
| | IRQ3 | IRQ2 | IRQ1 | IRQ4 | TMIG | TMOFH | TMOFL | TMOW |
| Initial value | 0 | 0 | 0 | 0 | 0 | 0 | 0 | 0 |
| Read/Write | R/(W) | R/(W) | R/(W) | R/(W) | R/(W) | R/(W) | R/(W) | R/(W) |

P1₀/TMOW pin function switch

| | |
|---|--------------------------------------|
| 0 | Functions as P1 ₀ I/O pin |
| 1 | Functions as TMOW output pin |

P1₁/TMOFL pin function switch

| | |
|---|--------------------------------------|
| 0 | Functions as P1 ₁ I/O pin |
| 1 | Functions as TMOFL output pin |

P1₂/TMOFH pin function switch

| | |
|---|--------------------------------------|
| 0 | Functions as P1 ₂ I/O pin |
| 1 | Functions as TMOFH output pin |

P1₃/TMIG pin function switch

| | |
|---|--------------------------------------|
| 0 | Functions as P1 ₃ I/O pin |
| 1 | Functions as TMIG input pin |

P1₄/IRQ₄/ADTRG pin function switch

| | |
|---|--|
| 0 | Functions as P1 ₄ I/O pin |
| 1 | Functions as IRQ ₄ /ADTRG input pin |

P1₅/IRQ₁/TMIC pin function switch

| | |
|---|---|
| 0 | Functions as P1 ₅ I/O pin |
| 1 | Functions as IRQ ₁ /TMIC input pin |

P1₆/IRQ₂ pin function switch

| | |
|---|---|
| 0 | Functions as P1 ₆ I/O pin |
| 1 | Functions as IRQ ₂ input pin |

P1₇/IRQ₃/TMIF pin function switch

| | |
|---|---|
| 0 | Functions as P1 ₇ I/O pin |
| 1 | Functions as IRQ ₃ /TMIF input pin |

| | | | | | | | | |
|---------------|-------|-------|-------|-------|-------|-------|-------|-------|
| Bit | 7 | 6 | 5 | 4 | 3 | 2 | 1 | 0 |
| | AEVL | AEVH | WDCKS | NCS | IRQ0 | RESO | UD | PWM |
| Initial value | 0 | 0 | 0 | 0 | 0 | 0 | 0 | 0 |
| Read/Write | R/(W) | R/(W) | R/(W) | R/(W) | R/(W) | R/(W) | R/(W) | R/(W) |

P3₀/PWM pin function switch

| | |
|---|--------------------------------------|
| 0 | Functions as P3 ₀ I/O pin |
| 1 | Functions as PWM output pin |

P3₁/UD pin function switch

| | |
|---|--------------------------------------|
| 0 | Functions as P3 ₁ I/O pin |
| 1 | Functions as UD input pin |

P3₂/RESO pin function switch

| | |
|---|---|
| 0 | Functions as P3 ₂ I/O pin |
| 1 | Functions as $\overline{\text{RESO}}$ I/O pin |

P4₃/IRQ0 pin function switch

| | |
|---|---|
| 0 | Functions as P4 ₃ I/O pin |
| 1 | Functions as $\overline{\text{IRQ0}}$ input pin |

TMIG noise canceler select

| | |
|---|--------------------------------------|
| 0 | Noise cancellation function not used |
| 1 | Noise cancellation function used |

Watchdog timer switch

| | |
|---|-------|
| 0 | ø8192 |
| 1 | øw/4 |

P3₆/AEVH pin function switch

| | |
|---|--------------------------------------|
| 0 | Functions as P3 ₆ I/O pin |
| 1 | Functions as AEVH input pin |

P3₇/AEVL pin function switch

| | |
|---|--------------------------------------|
| 0 | Functions as P3 ₇ I/O pin |
| 1 | Functions as AEVL input pin |

PWCR—PWM control register **H'D0** **14-bit PWM**

| Bit | 7 | 6 | 5 | 4 | 3 | 2 | 1 | 0 |
|---------------|---|---|---|---|---|---|-------|-------|
| | — | — | — | — | — | — | PWCR1 | PWCR0 |
| Initial value | 1 | 1 | 1 | 1 | 1 | 1 | 0 | 0 |
| Read/Write | — | — | — | — | — | — | W | W |

Clock select

| | |
|---|---|
| 0 | The input clock is $\phi/2$ ($t\phi^* = 2/\phi$) |
| | The conversion period is $16,384/\phi$, with a minimum modulation width of $1/\phi$ |
| 1 | The input clock is $\phi/4$ ($t\phi^* = 4/\phi$) |
| | The conversion period is $32,768/\phi$, with a minimum modulation width of $2/\phi$ |
| 1 | The input clock is $\phi/8$ ($t\phi^* = 8/\phi$) |
| | The conversion period is $65,536/\phi$, with a minimum modulation width of $4/\phi$ |
| 1 | The input clock is $\phi/16$ ($t\phi^* = 16/\phi$) |
| | The conversion period is $131,072/\phi$, with a minimum modulation width of $8/\phi$ |

Note: * $t\phi$: Period of PWM input clock

PWDRU—PWM data register U**H'D1****14-bit PWM**

| Bit | 7 | 6 | 5 | 4 | 3 | 2 | 1 | 0 |
|---------------|---|---|--------|--------|--------|--------|--------|--------|
| | — | — | PWDRU5 | PWDRU4 | PWDRU3 | PWDRU2 | PWDRU1 | PWDRU0 |
| Initial value | 1 | 1 | 0 | 0 | 0 | 0 | 0 | 0 |
| Read/Write | — | — | W | W | W | W | W | W |

Upper 6 bits of data for generating PWM waveform

PWDRL—PWM data register L**H'D2****14-bit PWM**

| Bit | 7 | 6 | 5 | 4 | 3 | 2 | 1 | 0 |
|---------------|--------|--------|--------|--------|--------|--------|--------|--------|
| | PWDRL7 | PWDRL6 | PWDRL5 | PWDRL4 | PWDRL3 | PWDRL2 | PWDRL1 | PWDRL0 |
| Initial value | 0 | 0 | 0 | 0 | 0 | 0 | 0 | 0 |
| Read/Write | W | W | W | W | W | W | W | W |

Lower 8 bits of data for generating PWM waveform

PDR1—Port data register 1**H'D4****I/O ports**

| Bit | 7 | 6 | 5 | 4 | 3 | 2 | 1 | 0 |
|---------------|-----------------|-----------------|-----------------|-----------------|-----------------|-----------------|-----------------|-----------------|
| | P1 ₇ | P1 ₆ | P1 ₅ | P1 ₄ | P1 ₃ | P1 ₂ | P1 ₁ | P1 ₀ |
| Initial value | 0 | 0 | 0 | 0 | 0 | 0 | 0 | 0 |
| Read/Write | R/W | R/W | R/W | R/W | R/W | R/W | R/W | R/W |

PDR3—Port data register 3**H'D6****I/O ports**

| Bit | 7 | 6 | 5 | 4 | 3 | 2 | 1 | 0 |
|---------------|-----------------|-----------------|-----------------|-----------------|-----------------|-----------------|-----------------|-----------------|
| | P3 ₇ | P3 ₆ | P3 ₅ | P3 ₄ | P3 ₃ | P3 ₂ | P3 ₁ | P3 ₀ |
| Initial value | 0 | 0 | 0 | 0 | 0 | 0 | 0 | 0 |
| Read/Write | R/W | R/W | R/W | R/W | R/W | R/W | R/W | R/W |

PDR4—Port data register 4**H'D7****I/O ports**

| Bit | 7 | 6 | 5 | 4 | 3 | 2 | 1 | 0 |
|---------------|---|---|---|---|-----------------|-----------------|-----------------|-----------------|
| | — | — | — | — | P4 ₃ | P4 ₂ | P4 ₁ | P4 ₀ |
| Initial value | 1 | 1 | 1 | 1 | 1 | 0 | 0 | 0 |
| Read/Write | — | — | — | — | R | R/W | R/W | R/W |

PDR5—Port data register 5**H'D8****I/O ports**

| | | | | | | | | |
|---------------|-----------------|-----------------|-----------------|-----------------|-----------------|-----------------|-----------------|-----------------|
| Bit | 7 | 6 | 5 | 4 | 3 | 2 | 1 | 0 |
| | P5 ₇ | P5 ₆ | P5 ₅ | P5 ₄ | P5 ₃ | P5 ₂ | P5 ₁ | P5 ₀ |
| Initial value | 0 | 0 | 0 | 0 | 0 | 0 | 0 | 0 |
| Read/Write | R/W | R/W | R/W | R/W | R/W | R/W | R/W | R/W |

PDR6—Port data register 6**H'D9****I/O ports**

| | | | | | | | | |
|---------------|-----------------|-----------------|-----------------|-----------------|-----------------|-----------------|-----------------|-----------------|
| Bit | 7 | 6 | 5 | 4 | 3 | 2 | 1 | 0 |
| | P6 ₇ | P6 ₆ | P6 ₅ | P6 ₄ | P6 ₃ | P6 ₂ | P6 ₁ | P6 ₀ |
| Initial value | 0 | 0 | 0 | 0 | 0 | 0 | 0 | 0 |
| Read/Write | R/W | R/W | R/W | R/W | R/W | R/W | R/W | R/W |

PDR7—Port data register 7**H'DA****I/O ports**

| | | | | | | | | |
|---------------|-----------------|-----------------|-----------------|-----------------|-----------------|-----------------|-----------------|-----------------|
| Bit | 7 | 6 | 5 | 4 | 3 | 2 | 1 | 0 |
| | P7 ₇ | P7 ₆ | P7 ₅ | P7 ₄ | P7 ₃ | P7 ₂ | P7 ₁ | P7 ₀ |
| Initial value | 0 | 0 | 0 | 0 | 0 | 0 | 0 | 0 |
| Read/Write | R/W | R/W | R/W | R/W | R/W | R/W | R/W | R/W |

PDR8—Port data register 8**H'DB****I/O ports**

| | | | | | | | | |
|---------------|-----------------|-----------------|-----------------|-----------------|-----------------|-----------------|-----------------|-----------------|
| Bit | 7 | 6 | 5 | 4 | 3 | 2 | 1 | 0 |
| | P8 ₇ | P8 ₆ | P8 ₅ | P8 ₄ | P8 ₃ | P8 ₂ | P8 ₁ | P8 ₀ |
| Initial value | 0 | 0 | 0 | 0 | 0 | 0 | 0 | 0 |
| Read/Write | R/W | R/W | R/W | R/W | R/W | R/W | R/W | R/W |

PDRA—Port data register A**H'DD****I/O ports**

| | | | | | | | | |
|---------------|---|---|---|---|-----------------|-----------------|-----------------|-----------------|
| Bit | 7 | 6 | 5 | 4 | 3 | 2 | 1 | 0 |
| | — | — | — | — | PA ₃ | PA ₂ | PA ₁ | PA ₀ |
| Initial value | 1 | 1 | 1 | 1 | 0 | 0 | 0 | 0 |
| Read/Write | — | — | — | — | R/W | R/W | R/W | R/W |

PDRB—Port data register B**H'DE****I/O ports**

| | | | | | | | | |
|---------------|-----------------|-----------------|-----------------|-----------------|-----------------|-----------------|-----------------|-----------------|
| Bit | 7 | 6 | 5 | 4 | 3 | 2 | 1 | 0 |
| | PB ₇ | PB ₆ | PB ₅ | PB ₄ | PB ₃ | PB ₂ | PB ₁ | PB ₀ |
| Initial value | | | | | | | | |
| Read/Write | R | R | R | R | R | R | R | R |

PUCR1—Port pull-up control register 1**H'E0****I/O ports**

| | | | | | | | | |
|---------------|--------------------|--------------------|--------------------|--------------------|--------------------|--------------------|--------------------|--------------------|
| Bit | 7 | 6 | 5 | 4 | 3 | 2 | 1 | 0 |
| | PUCR1 ₇ | PUCR1 ₆ | PUCR1 ₅ | PUCR1 ₄ | PUCR1 ₃ | PUCR1 ₂ | PUCR1 ₁ | PUCR1 ₀ |
| Initial value | 0 | 0 | 0 | 0 | 0 | 0 | 0 | 0 |
| Read/Write | R/W | R/W | R/W | R/W | R/W | R/W | R/W | R/W |

PUCR3—Port pull-up control register 3**H'E1****I/O ports**

| | | | | | | | | |
|---------------|--------------------|--------------------|--------------------|--------------------|--------------------|--------------------|--------------------|--------------------|
| Bit | 7 | 6 | 5 | 4 | 3 | 2 | 1 | 0 |
| | PUCR3 ₇ | PUCR3 ₆ | PUCR3 ₅ | PUCR3 ₄ | PUCR3 ₃ | PUCR3 ₂ | PUCR3 ₁ | PUCR3 ₀ |
| Initial value | 0 | 0 | 0 | 0 | 0 | 0 | 0 | 0 |
| Read/Write | R/W | R/W | R/W | R/W | R/W | R/W | R/W | R/W |

PUCR5—Port pull-up control register 5**H'E2****I/O ports**

| | | | | | | | | |
|---------------|--------------------|--------------------|--------------------|--------------------|--------------------|--------------------|--------------------|--------------------|
| Bit | 7 | 6 | 5 | 4 | 3 | 2 | 1 | 0 |
| | PUCR5 ₇ | PUCR5 ₆ | PUCR5 ₅ | PUCR5 ₄ | PUCR5 ₃ | PUCR5 ₂ | PUCR5 ₁ | PUCR5 ₀ |
| Initial value | 0 | 0 | 0 | 0 | 0 | 0 | 0 | 0 |
| Read/Write | R/W | R/W | R/W | R/W | R/W | R/W | R/W | R/W |

PUCR6—Port pull-up control register 6**H'E3****I/O ports**

| | | | | | | | | |
|---------------|--------------------|--------------------|--------------------|--------------------|--------------------|--------------------|--------------------|--------------------|
| Bit | 7 | 6 | 5 | 4 | 3 | 2 | 1 | 0 |
| | PUCR6 ₇ | PUCR6 ₆ | PUCR6 ₅ | PUCR6 ₄ | PUCR6 ₃ | PUCR6 ₂ | PUCR6 ₁ | PUCR6 ₀ |
| Initial value | 0 | 0 | 0 | 0 | 0 | 0 | 0 | 0 |
| Read/Write | R/W | R/W | R/W | R/W | R/W | R/W | R/W | R/W |

PCR1—Port control register 1**H'E4****I/O ports**

| | | | | | | | | |
|---------------|-------------------|-------------------|-------------------|-------------------|-------------------|-------------------|-------------------|-------------------|
| Bit | 7 | 6 | 5 | 4 | 3 | 2 | 1 | 0 |
| | PCR1 ₇ | PCR1 ₆ | PCR1 ₅ | PCR1 ₄ | PCR1 ₃ | PCR1 ₂ | PCR1 ₁ | PCR1 ₀ |
| Initial value | 0 | 0 | 0 | 0 | 0 | 0 | 0 | 0 |
| Read/Write | W | W | W | W | W | W | W | W |

Port 1 input/output select

| | |
|---|------------|
| 0 | Input pin |
| 1 | Output pin |

PCR3—Port control register 3**H'E6****I/O ports**

| | | | | | | | | |
|---------------|-------------------|-------------------|-------------------|-------------------|-------------------|-------------------|-------------------|-------------------|
| Bit | 7 | 6 | 5 | 4 | 3 | 2 | 1 | 0 |
| | PCR3 ₇ | PCR3 ₆ | PCR3 ₅ | PCR3 ₄ | PCR3 ₃ | PCR3 ₂ | PCR3 ₁ | PCR3 ₀ |
| Initial value | 0 | 0 | 0 | 0 | 0 | 0 | 0 | 0 |
| Read/Write | W | W | W | W | W | W | W | W |

Port 3 input/output select

| | |
|---|------------|
| 0 | Input pin |
| 1 | Output pin |

PCR4—Port control register 4**H'E7****I/O ports**

| | | | | | | | | |
|---------------|---|---|---|---|---|-------------------|-------------------|-------------------|
| Bit | 7 | 6 | 5 | 4 | 3 | 2 | 1 | 0 |
| | — | — | — | — | — | PCR4 ₂ | PCR4 ₁ | PCR4 ₀ |
| Initial value | 1 | 1 | 1 | 1 | 1 | 0 | 0 | 0 |
| Read/Write | — | — | — | — | — | W | W | W |

Port 4 input/output select

| | |
|---|------------|
| 0 | Input pin |
| 1 | Output pin |

PCR5—Port control register 5**H'E8****I/O ports**

| | | | | | | | | |
|---------------|-------------------|-------------------|-------------------|-------------------|-------------------|-------------------|-------------------|-------------------|
| Bit | 7 | 6 | 5 | 4 | 3 | 2 | 1 | 0 |
| | PCR5 ₇ | PCR5 ₆ | PCR5 ₅ | PCR5 ₄ | PCR5 ₃ | PCR5 ₂ | PCR5 ₁ | PCR5 ₀ |
| Initial value | 0 | 0 | 0 | 0 | 0 | 0 | 0 | 0 |
| Read/Write | W | W | W | W | W | W | W | W |

Port 5 input/output select

| | |
|---|------------|
| 0 | Input pin |
| 1 | Output pin |

PCR6—Port control register 6**H'E9****I/O ports**

| | | | | | | | | |
|---------------|-------------------|-------------------|-------------------|-------------------|-------------------|-------------------|-------------------|-------------------|
| Bit | 7 | 6 | 5 | 4 | 3 | 2 | 1 | 0 |
| | PCR6 ₇ | PCR6 ₆ | PCR6 ₅ | PCR6 ₄ | PCR6 ₃ | PCR6 ₂ | PCR6 ₁ | PCR6 ₀ |
| Initial value | 0 | 0 | 0 | 0 | 0 | 0 | 0 | 0 |
| Read/Write | W | W | W | W | W | W | W | W |

Port 6 input/output select

| | |
|---|------------|
| 0 | Input pin |
| 1 | Output pin |

PCR7—Port control register 7**H'EA****I/O ports**

| | | | | | | | | |
|---------------|-------------------|-------------------|-------------------|-------------------|-------------------|-------------------|-------------------|-------------------|
| Bit | 7 | 6 | 5 | 4 | 3 | 2 | 1 | 0 |
| | PCR7 ₇ | PCR7 ₆ | PCR7 ₅ | PCR7 ₄ | PCR7 ₃ | PCR7 ₂ | PCR7 ₁ | PCR7 ₀ |
| Initial value | 0 | 0 | 0 | 0 | 0 | 0 | 0 | 0 |
| Read/Write | W | W | W | W | W | W | W | W |

Port 7 input/output select

| | |
|---|------------|
| 0 | Input pin |
| 1 | Output pin |

PCR8—Port control register 8**H'EB****I/O ports**

| Bit | 7 | 6 | 5 | 4 | 3 | 2 | 1 | 0 |
|---------------|-------------------|-------------------|-------------------|-------------------|-------------------|-------------------|-------------------|-------------------|
| | PCR8 ₇ | PCR8 ₆ | PCR8 ₅ | PCR8 ₄ | PCR8 ₃ | PCR8 ₂ | PCR8 ₁ | PCR8 ₀ |
| Initial value | 0 | 0 | 0 | 0 | 0 | 0 | 0 | 0 |
| Read/Write | W | W | W | W | W | W | W | W |

Port 8 input/output select

| | |
|---|------------|
| 0 | Input pin |
| 1 | Output pin |

PCRA—Port control register A**H'ED****I/O ports**

| Bit | 7 | 6 | 5 | 4 | 3 | 2 | 1 | 0 |
|---------------|---|---|---|---|-------------------|-------------------|-------------------|-------------------|
| | — | — | — | — | PCRA ₃ | PCRA ₂ | PCRA ₁ | PCRA ₀ |
| Initial value | 0 | 0 | 0 | 0 | 0 | 0 | 0 | 0 |
| Read/Write | — | — | — | — | R/W | R/W | R/W | R/W |

Port A input/output select

| | |
|---|------------|
| 0 | Input pin |
| 1 | Output pin |

| | | | | | | | | |
|---------------|------|------|------|------|------|---|-----|-----|
| Bit | 7 | 6 | 5 | 4 | 3 | 2 | 1 | 0 |
| | SSBY | STS2 | STS1 | STS0 | LSON | — | MA1 | MA0 |
| Initial value | 0 | 0 | 0 | 0 | 0 | 1 | 1 | 1 |
| Read/Write | R/W | R/W | R/W | R/W | R/W | — | R/W | R/W |

Active (medium-speed) mode clock select

| | | |
|---|---|-----------------------|
| 0 | 0 | $\emptyset_{osc}/16$ |
| | 1 | $\emptyset_{osc}/32$ |
| 1 | 0 | $\emptyset_{osc}/64$ |
| | 1 | $\emptyset_{osc}/128$ |

Low speed on flag

| | |
|---|--|
| 0 | The CPU operates on the system clock (\emptyset) |
| 1 | The CPU operates on the subclock (\emptyset_{SUB}) |

Standby timer select 2 to 0

| | | | |
|---|---|---|----------------------------|
| 0 | 0 | 0 | Wait time = 8,192 states |
| | | 1 | Wait time = 16,384 states |
| 1 | 0 | 0 | Wait time = 32,768 states |
| | | 1 | Wait time = 65,536 states |
| 1 | 0 | 0 | Wait time = 131,072 states |
| | | 1 | Wait time = 2 states |
| | 1 | 0 | Wait time = 8 states |
| | | 1 | Wait time = 16 states |

Software standby

| | |
|---|---|
| 0 | <ul style="list-style-type: none"> When a SLEEP instruction is executed in active mode, a transition is made to sleep mode When a SLEEP instruction is executed in subactive mode, a transition is made to subsleep mode |
| 1 | <ul style="list-style-type: none"> When a SLEEP instruction is executed in active mode, a transition is made to standby mode or watch mode When a SLEEP instruction is executed in subactive mode, a transition is made to watch mode |

| | | | | | | | | |
|---------------|---|---|---|-------|------|------|-----|-----|
| Bit | 7 | 6 | 5 | 4 | 3 | 2 | 1 | 0 |
| | — | — | — | NESEL | DTON | MSON | SA1 | SA0 |
| Initial value | 1 | 1 | 1 | 1 | 0 | 0 | 0 | 0 |
| Read/Write | — | — | — | R/W | R/W | R/W | R/W | R/W |

Subactive mode clock select

| | | |
|---|---|------------|
| 0 | 0 | $\phi_W/8$ |
| | 1 | $\phi_W/4$ |
| 1 | * | $\phi_W/2$ |

Medium speed on flag

| | |
|---|--|
| 0 | Operates in active (high-speed) mode |
| 1 | Operates in active (medium-speed) mode |

*: Don't care

Direct transfer on flag

| | |
|---|---|
| 0 | <ul style="list-style-type: none"> When a SLEEP instruction is executed in active mode, a transition is made to standby mode, watch mode, or sleep mode When a SLEEP instruction is executed in subactive mode, a transition is made to watch mode or subsleep mode |
| 1 | <ul style="list-style-type: none"> When a SLEEP instruction is executed in active (high-speed) mode, a direct transition is made to active (medium-speed) mode if SSBY = 0, MSON = 1, and LSON = 0, or to subactive mode if SSBY = 1, TMA3 = 1, and LSON = 1 When a SLEEP instruction is executed in active (medium-speed) mode, a direct transition is made to active (high-speed) mode if SSBY = 0, MSON = 0, and LSON = 0, or to subactive mode if SSBY = 1, TMA3 = 1, and LSON = 1 When a SLEEP instruction is executed in subactive mode, a direct transition is made to active (high-speed) mode if SSBY = 1, TMA3 = 1, LSON = 0, and MSON = 0, or to active (medium-speed) mode if SSBY = 1, TMA3 = 1, LSON = 0, and MSON = 1 |

Noise elimination sampling frequency select

| | |
|---|----------------------------------|
| 0 | Sampling rate is $\phi_{OSC}/16$ |
| 1 | Sampling rate is $\phi_{OSC}/4$ |

| Bit | 7 | 6 | 5 | 4 | 3 | 2 | 1 | 0 |
|---------------|---|---|---|------|------|------|------|------|
| | — | — | — | IEG4 | IEG3 | IEG2 | IEG1 | IEG0 |
| Initial value | 0 | 1 | 1 | 0 | 0 | 0 | 0 | 0 |
| Read/Write | — | — | — | R/W | R/W | R/W | R/W | R/W |

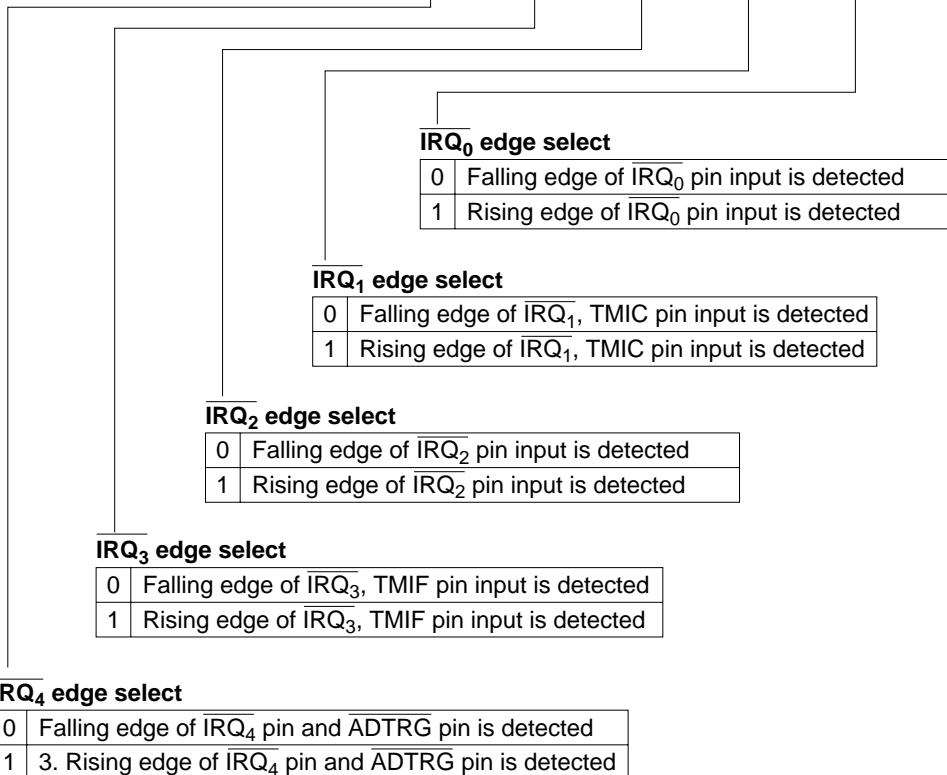

| Bit | 7 | 6 | 5 | 4 | 3 | 2 | 1 | 0 |
|---------------|-------|-----|-------|------|------|------|------|------|
| | IENTA | — | IENWP | IEN4 | IEN3 | IEN2 | IEN1 | IEN0 |
| Initial value | 0 | 0 | 0 | 0 | 0 | 0 | 0 | 0 |
| Read/Write | R/W | R/W | R/W | R/W | R/W | R/W | R/W | R/W |

IRQ₄ to IRQ₀ interrupt enable

| | |
|---|--|
| 0 | Disables $\overline{\text{IRQ}}_4$ to $\overline{\text{IRQ}}_0$ interrupt requests |
| 1 | Enables $\overline{\text{IRQ}}_4$ to $\overline{\text{IRQ}}_0$ interrupt requests |

Wakeup interrupt enable

| | |
|---|--|
| 0 | Disables $\overline{\text{WKP}}_7$ to $\overline{\text{WKP}}_0$ interrupt requests |
| 1 | Enables $\overline{\text{WKP}}_7$ to $\overline{\text{WKP}}_0$ interrupt requests |

Timer A interrupt enable

| | |
|---|-------------------------------------|
| 0 | Disables timer A interrupt requests |
| 1 | Enables timer A interrupt requests |

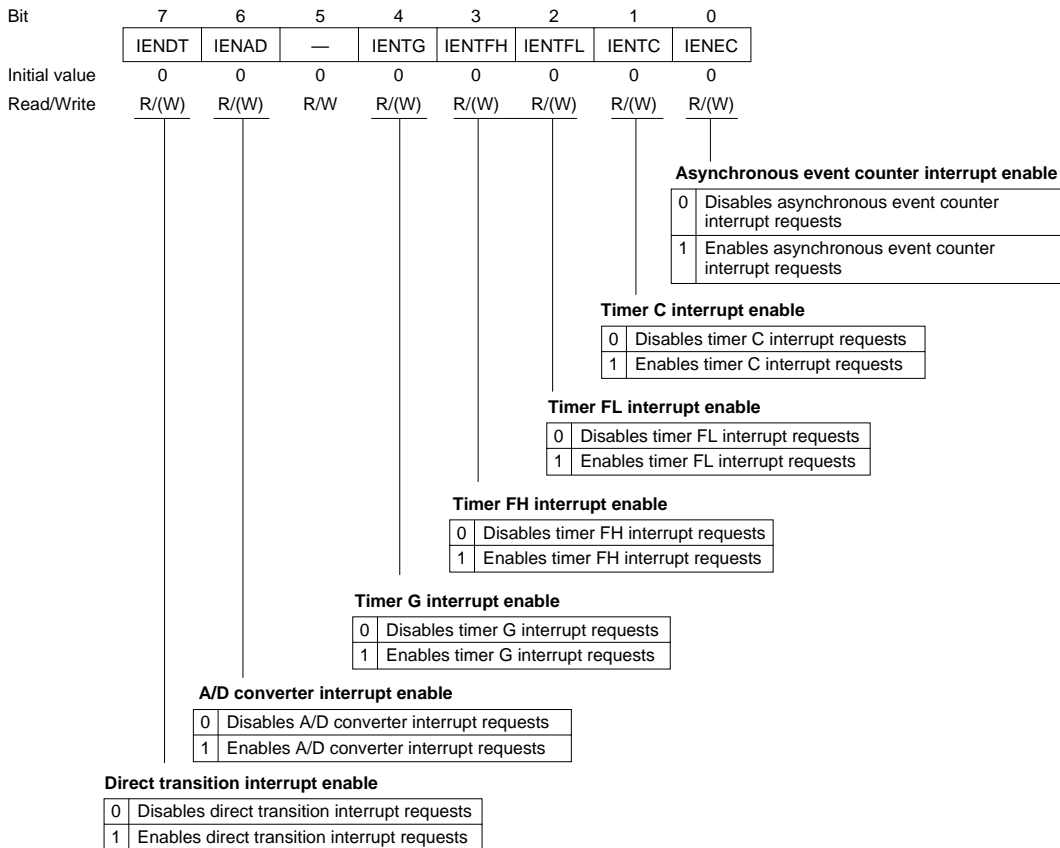

| | | | | | | | | |
|---------------|-------|-----|---|-------|-------|-------|-------|-------|
| Bit | 7 | 6 | 5 | 4 | 3 | 2 | 1 | 0 |
| | IRRTA | — | — | IRRI4 | IRRI3 | IRRI2 | IRRI1 | IRRI0 |
| Initial value | 0 | 0 | 1 | 0 | 0 | 0 | 0 | 0 |
| Read/Write | R/W* | R/W | — | R/W* | R/W* | R/W* | R/W* | R/W* |

IRQ4 to IRQ0 interrupt request flags

| | |
|---|--|
| 0 | Clearing conditions: When IRRIn = 1, it is cleared by writing 0 |
| 1 | Setting conditions: When pin IRQn is designated for interrupt input and the designated signal edge is input |

(n = 4 to 0)

Timer A interrupt request flag

| | |
|---|--|
| 0 | Clearing conditions: When IRRTA = 1, it is cleared by writing 0 |
| 1 | Setting conditions: When the timer A counter value overflows (rom H'FF to H'00) |

Note: * Bits 7 and 4 to 0 can only be written with 0, for flag clearing.

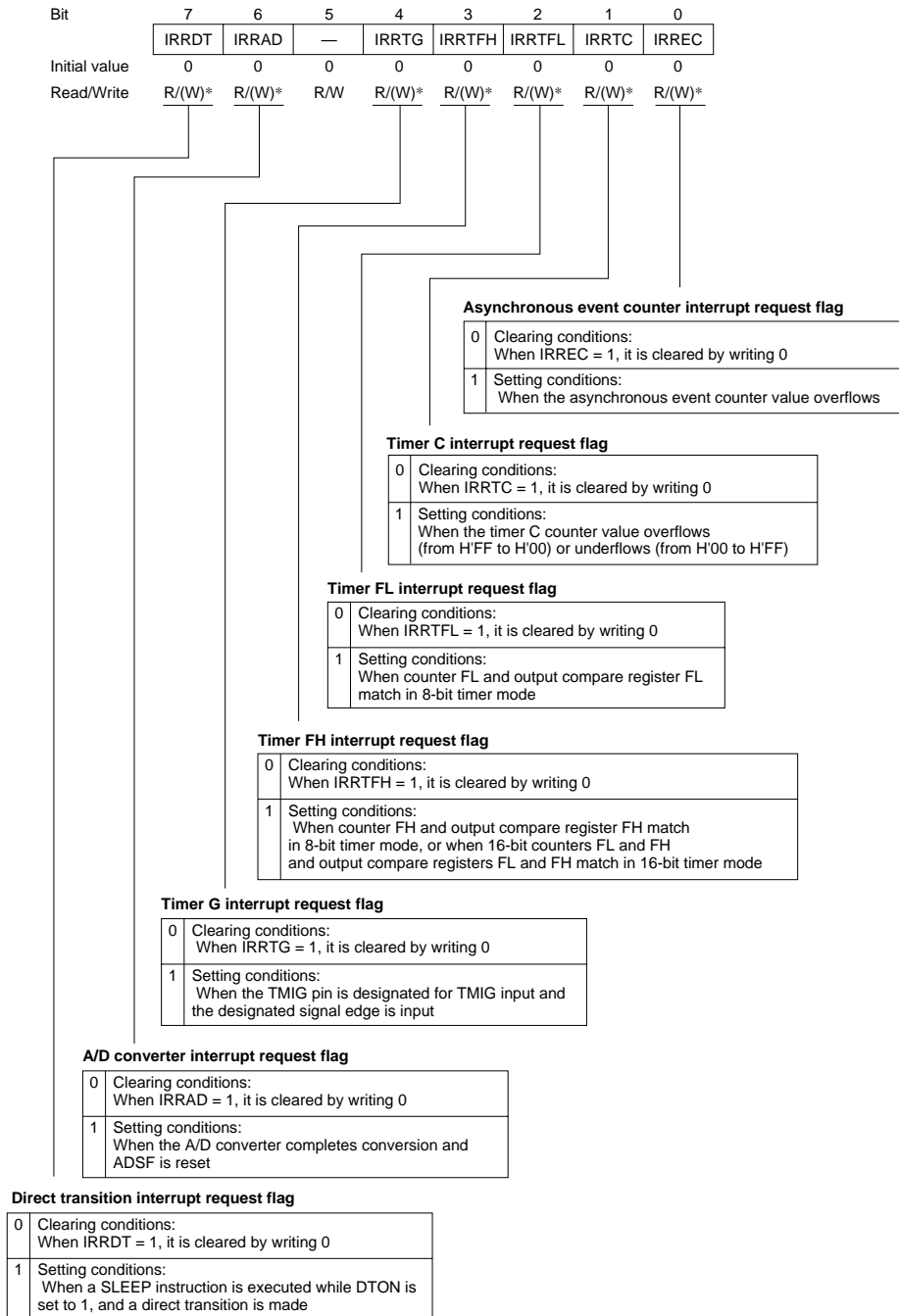

Note: * Bits 7, 6 and 4 to 0 can only be written with 0, for flag clearing.

| Bit | 7 | 6 | 5 | 4 | 3 | 2 | 1 | 0 |
|---------------|--------|--------|--------|--------|--------|--------|--------|--------|
| | IWPF7 | IWPF6 | IWPF5 | IWPF4 | IWPF3 | IWPF2 | IWPF1 | IWPF0 |
| Initial value | 0 | 0 | 0 | 0 | 0 | 0 | 0 | 0 |
| Read/Write | R/(W)* | R/(W)* | R/(W)* | R/(W)* | R/(W)* | R/(W)* | R/(W)* | R/(W)* |

Wakeup interrupt request register

| | |
|---|---|
| 0 | Clearing conditions: When IWPF _n = 1, it is cleared by writing 0 |
| 1 | Setting conditions: When pin WKP _n is designated for wakeup input and a falling edge is input at that pin |

(n = 7 to 0)

Note: * All bits can only be written with 0, for flag clearing.

| Bit | 7 | 6 | 5 | 4 | 3 | 2 | 1 | 0 |
|---------------|-----|----------|----------|---------|---------|---------|---------|---------|
| | — | S31CKSTP | S32CKSTP | ADCKSTP | TGCKSTP | TFCKSTP | TCCKSTP | TACKSTP |
| Initial value | 1 | 1 | 1 | 1 | 1 | 1 | 1 | 1 |
| Read/Write | R/W | R/W | R/W | R/W | R/W | R/W | R/W | R/W |

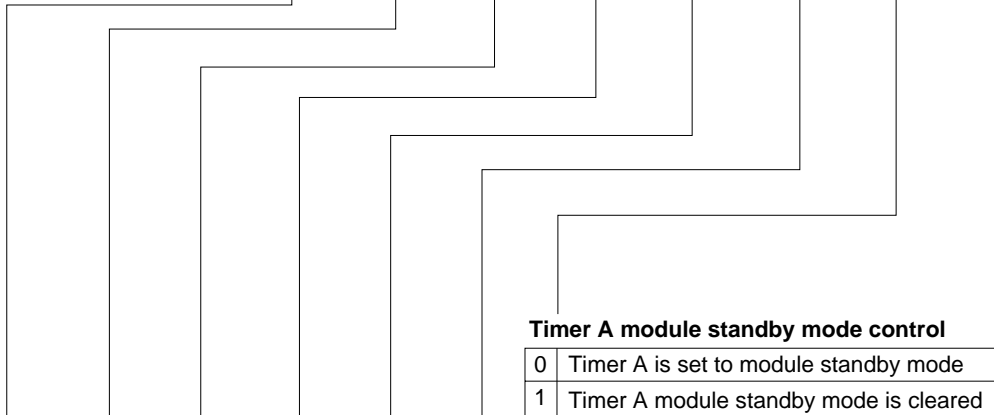

Timer A module standby mode control

| | |
|---|--|
| 0 | Timer A is set to module standby mode |
| 1 | Timer A module standby mode is cleared |

Timer C module standby mode control

| | |
|---|--|
| 0 | Timer C is set to module standby mode |
| 1 | Timer C module standby mode is cleared |

Timer F module standby mode control

| | |
|---|--|
| 0 | Timer F is set to module standby mode |
| 1 | Timer F module standby mode is cleared |

Timer G interrupt enable

| | |
|---|--|
| 0 | Timer G is set to module standby mode |
| 1 | Timer G module standby mode is cleared |

A/D converter module standby mode control

| | |
|---|--|
| 0 | A/D converter is set to module standby mode |
| 1 | A/D converter module standby mode is cleared |

SCI3-2 module standby mode control

| | |
|---|---------------------------------------|
| 0 | SCI3-2 is set to module standby mode |
| 1 | SCI3-2 module standby mode is cleared |

SCI3-1 module standby mode control

| | |
|---|---------------------------------------|
| 0 | SCI3-1 is set to module standby mode |
| 1 | SCI3-1 module standby mode is cleared |

| | | | | | | | | |
|---------------|---|---|---|---|---------|---------|---------|---------|
| Bit | 7 | 6 | 5 | 4 | 3 | 2 | 1 | 0 |
| | — | — | — | — | AECKSTP | WDCKSTP | PWCKSTP | LDCKSTP |
| Initial value | 1 | 1 | 1 | 1 | 1 | 1 | 1 | 1 |
| Read/Write | — | — | — | — | R/W | R/W | R/W | R/W |

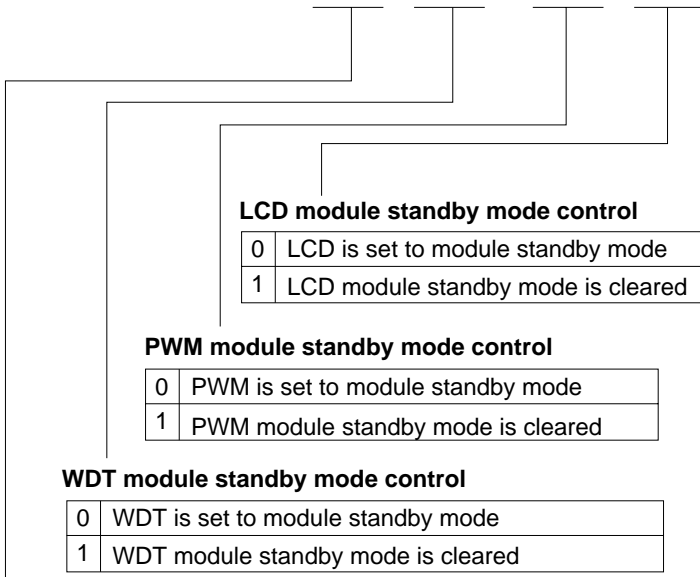

LCD module standby mode control

| | |
|---|------------------------------------|
| 0 | LCD is set to module standby mode |
| 1 | LCD module standby mode is cleared |

PWM module standby mode control

| | |
|---|------------------------------------|
| 0 | PWM is set to module standby mode |
| 1 | PWM module standby mode is cleared |

WDT module standby mode control

| | |
|---|------------------------------------|
| 0 | WDT is set to module standby mode |
| 1 | WDT module standby mode is cleared |

Asynchronous event counter module standby mode control

| | |
|---|---|
| 0 | Asynchronous event counter is set to module standby mode |
| 1 | Asynchronous event counter module standby mode is cleared |

Appendix C I/O Port Block Diagrams

C.1 Block Diagrams of Port 1

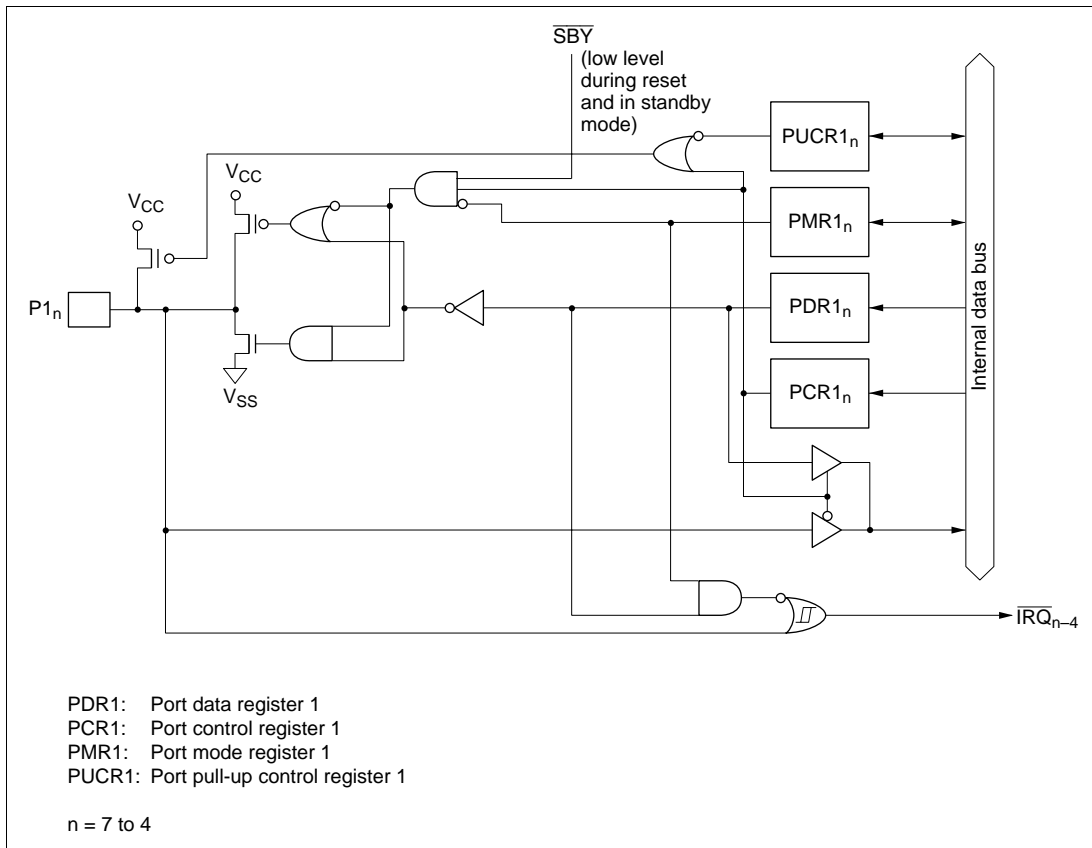

Figure C.1 (a) Port 1 Block Diagram (Pins P1₇ to P1₄)

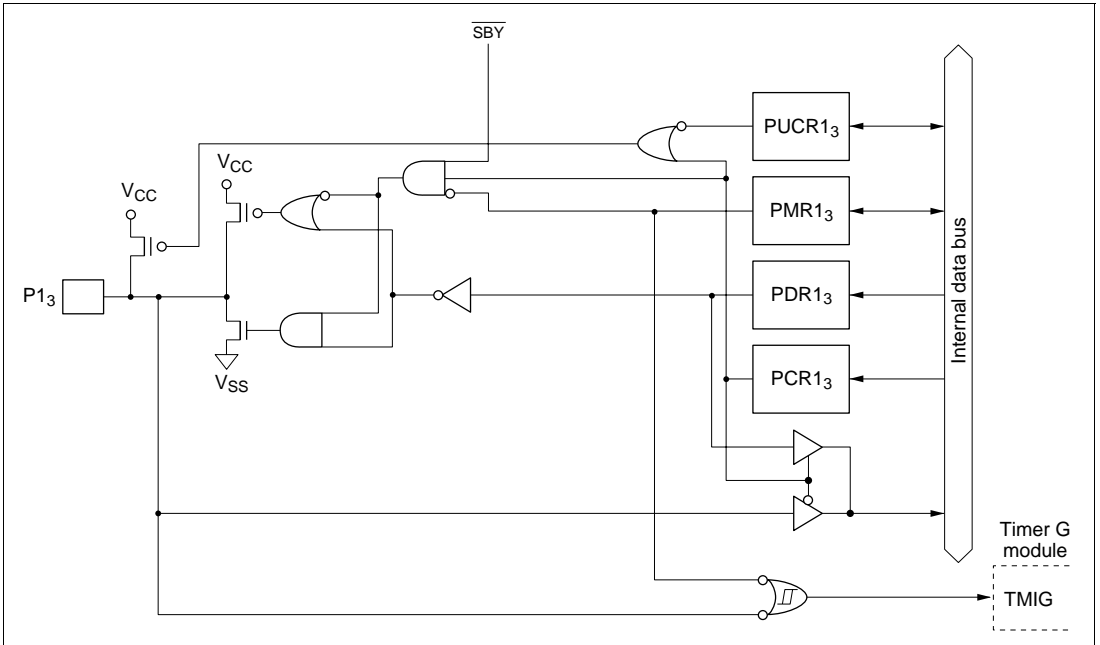

Figure C.1 (b) Port 1 Block Diagram (Pin P1₃)

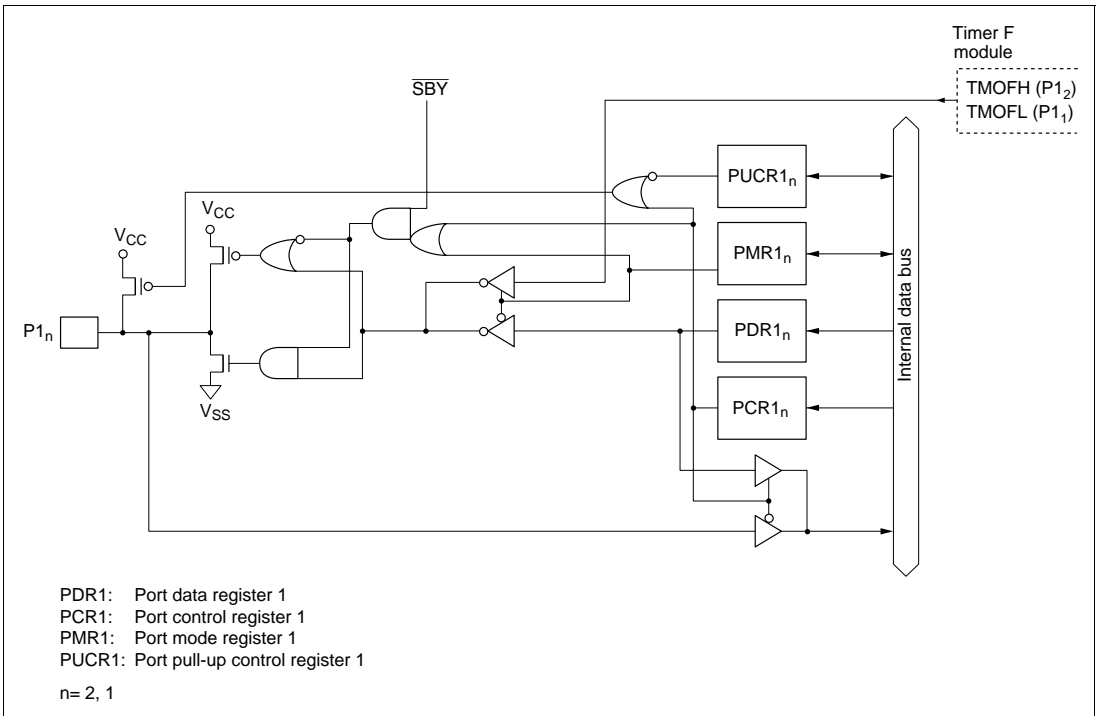

Figure C.1 (c) Port 1 Block Diagram (Pin P1₂, P1₁)

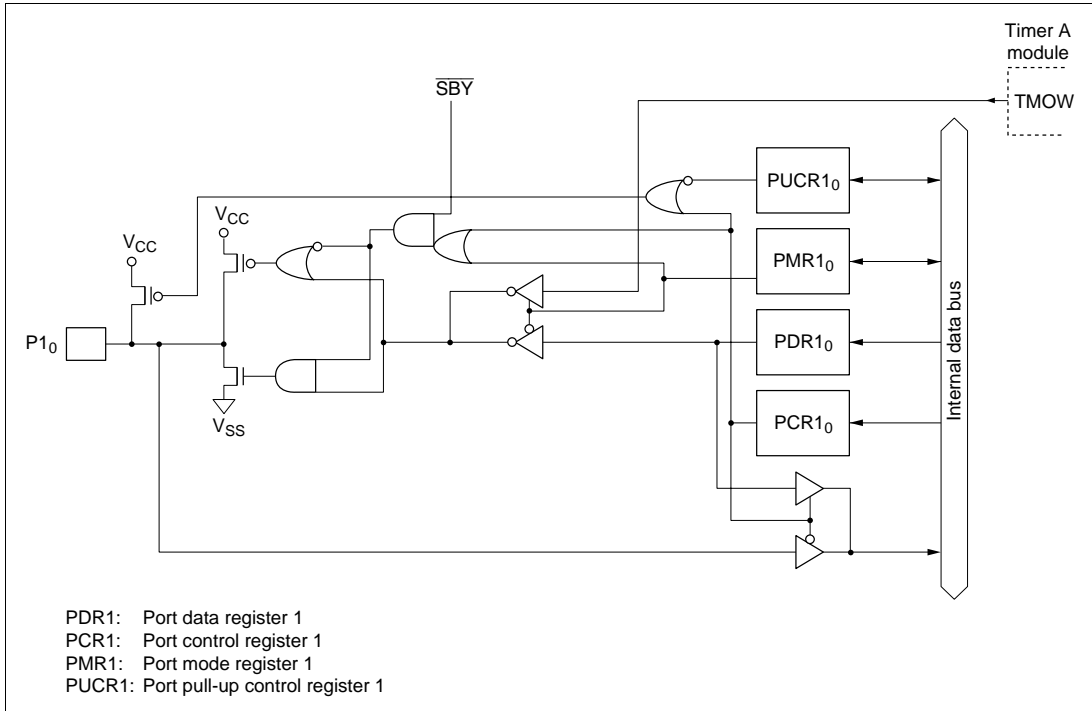

Figure C.1 (d) Port 1 Block Diagram (Pin P10)

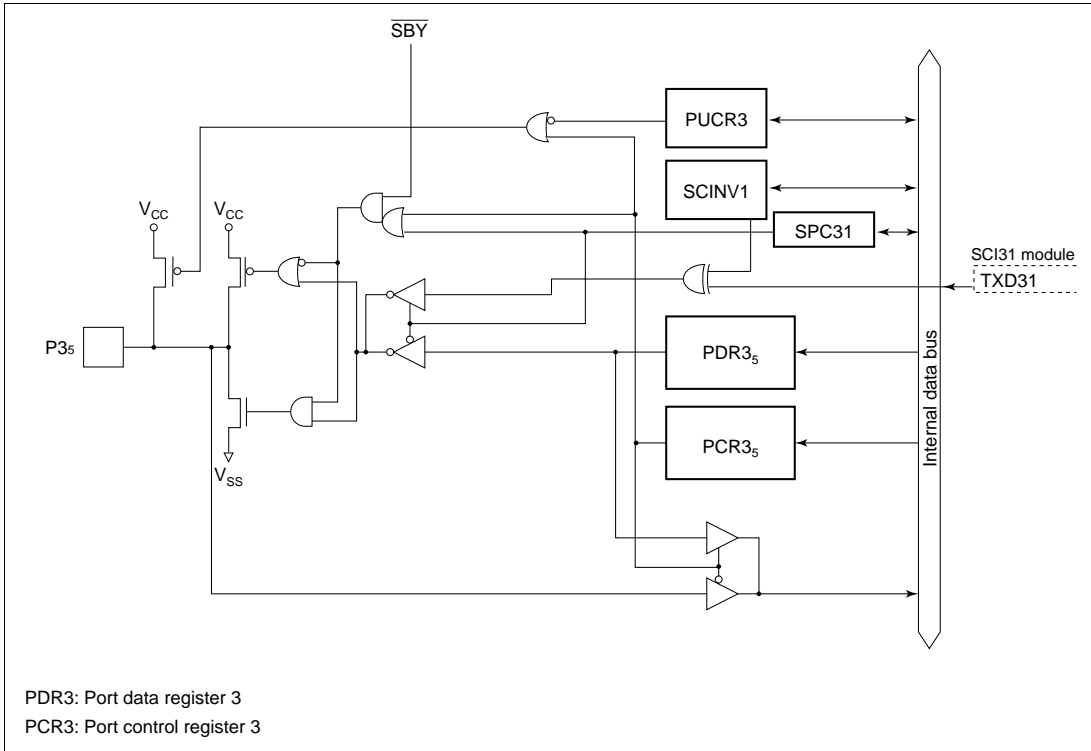

Figure C.2 (b) Port 3 Block Diagram (Pin P3₅)

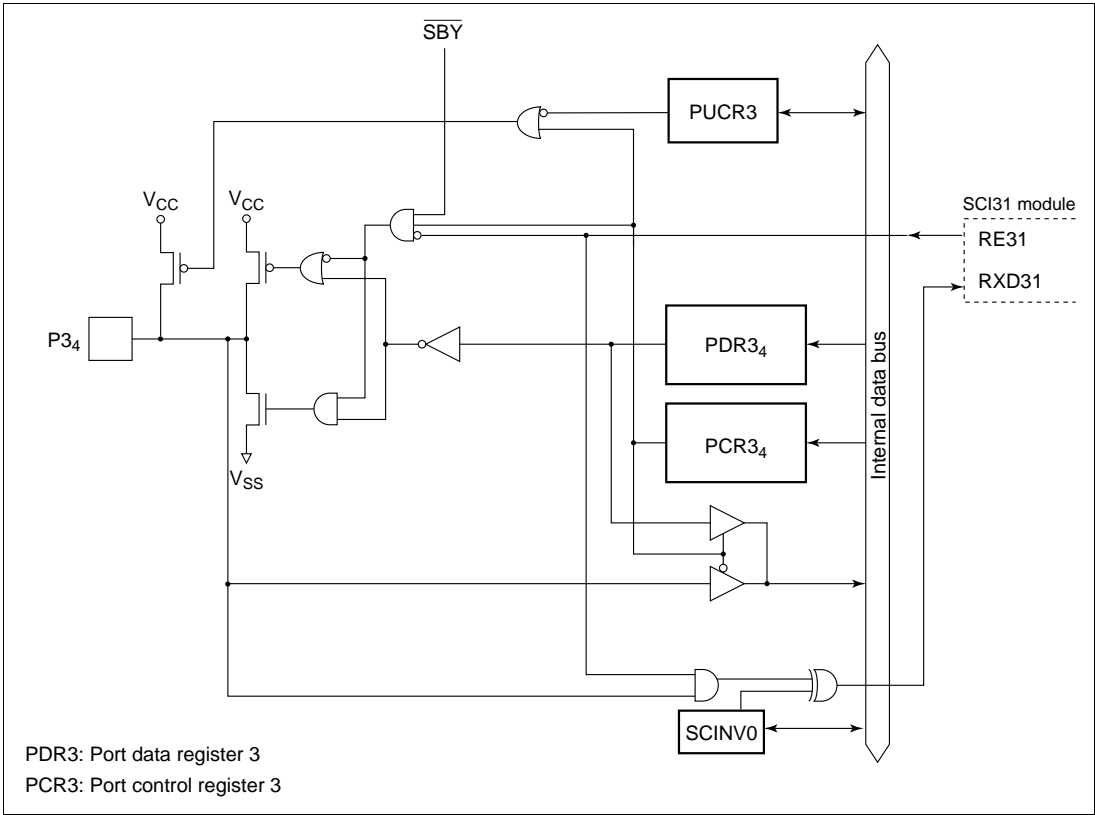

Figure C.2 (c) Port 3 Block Diagram (Pin P34)

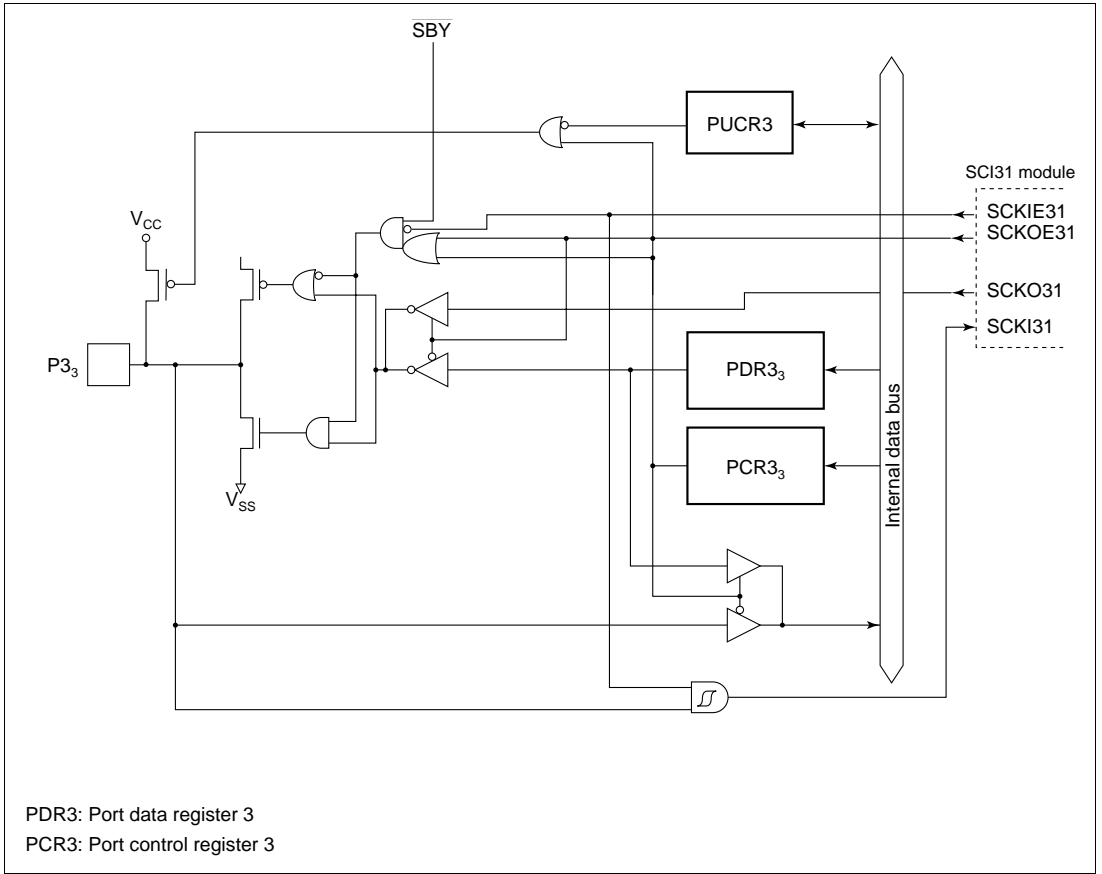

Figure C.2 (d) Port 3 Block Diagram (Pin P3₃)

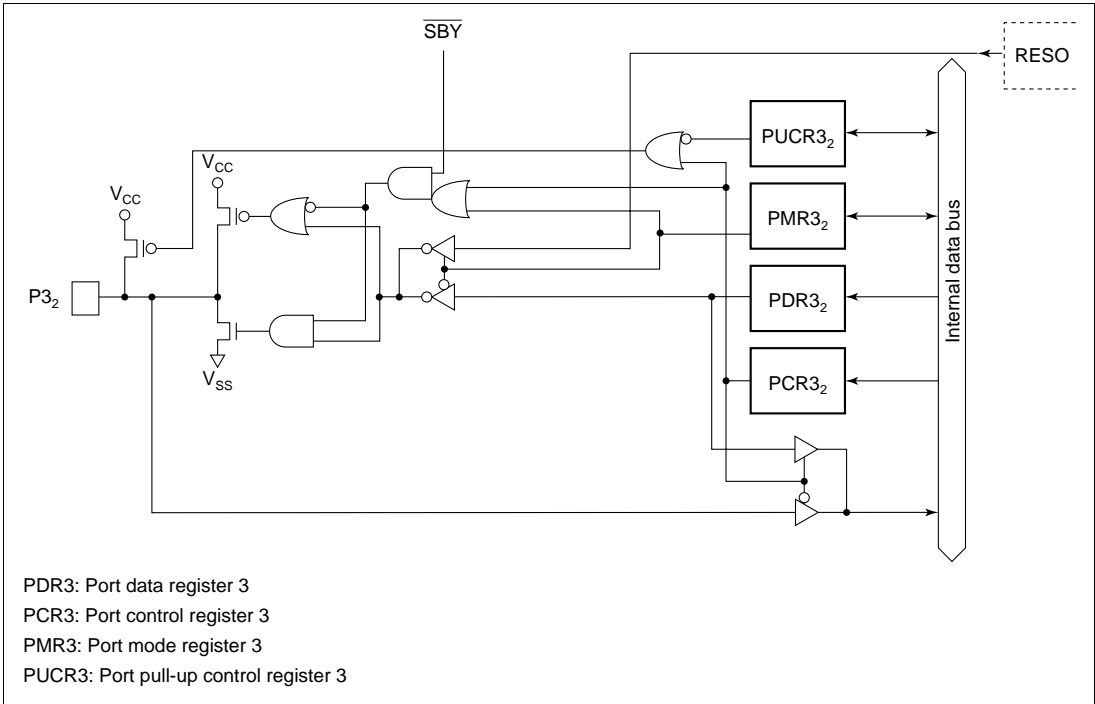

Figure C.2 (e) Port 3 Block Diagram (Pin P3₂)

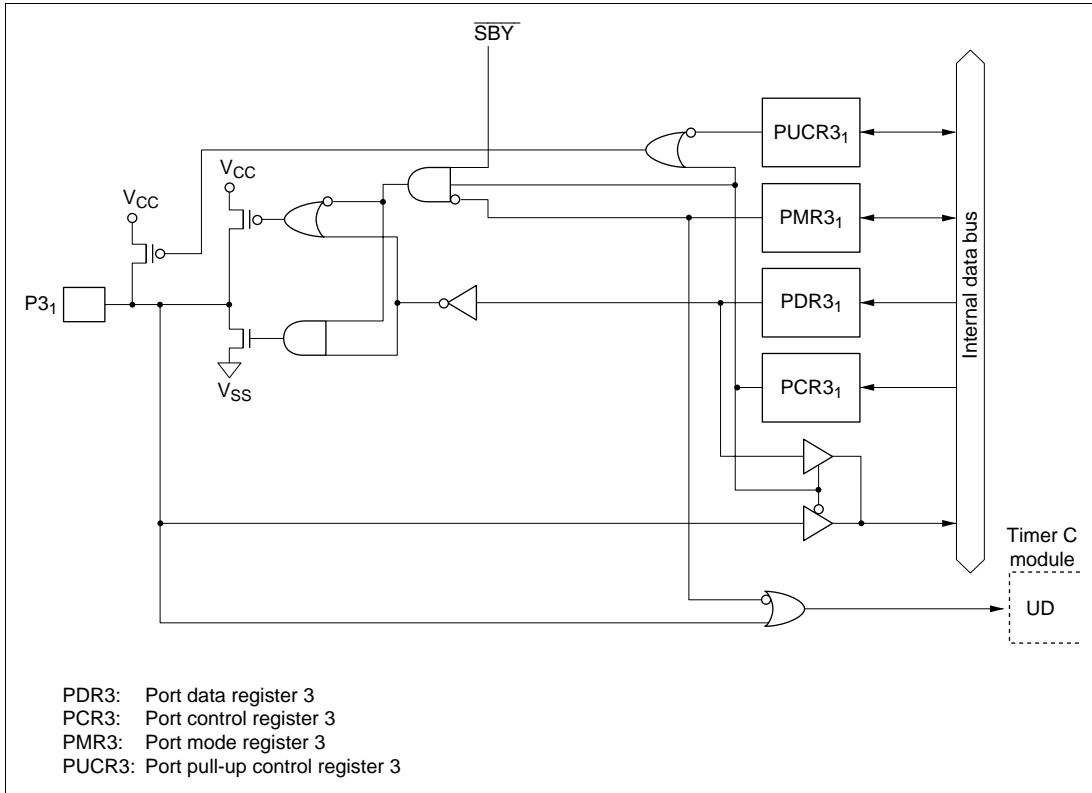

Figure C.2 (f) Port 3 Block Diagram (Pin P3₁)

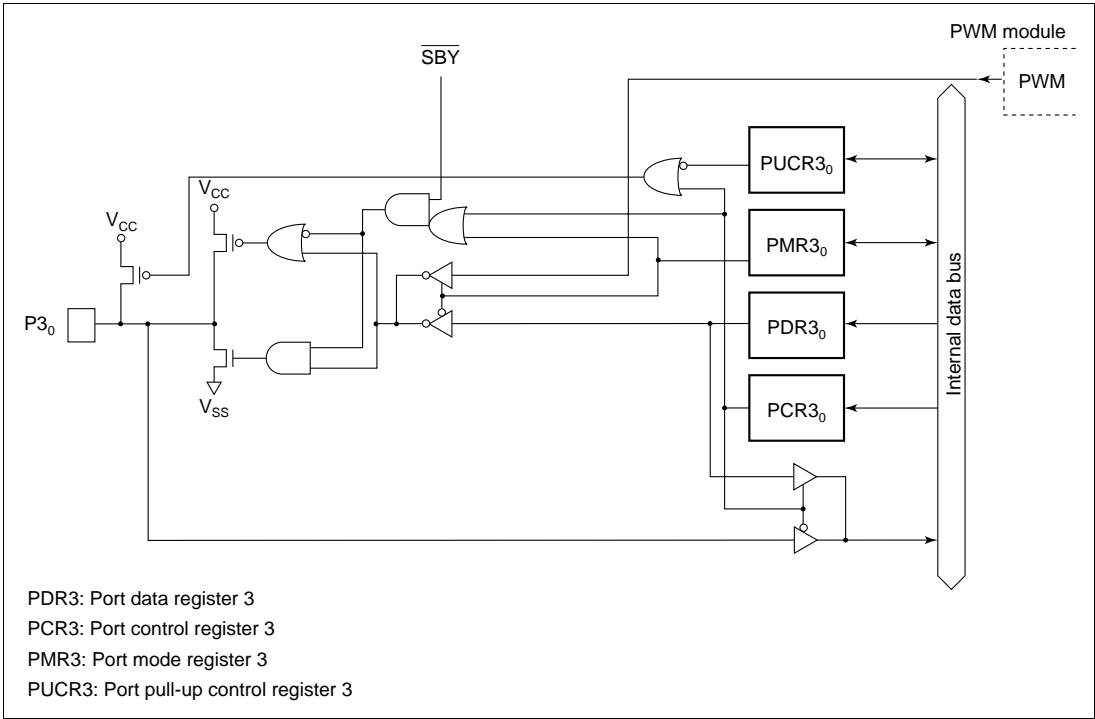

Figure C.2 (g) Port 3 Block Diagram (Pin P3₀)

C.3 Block Diagrams of Port 4

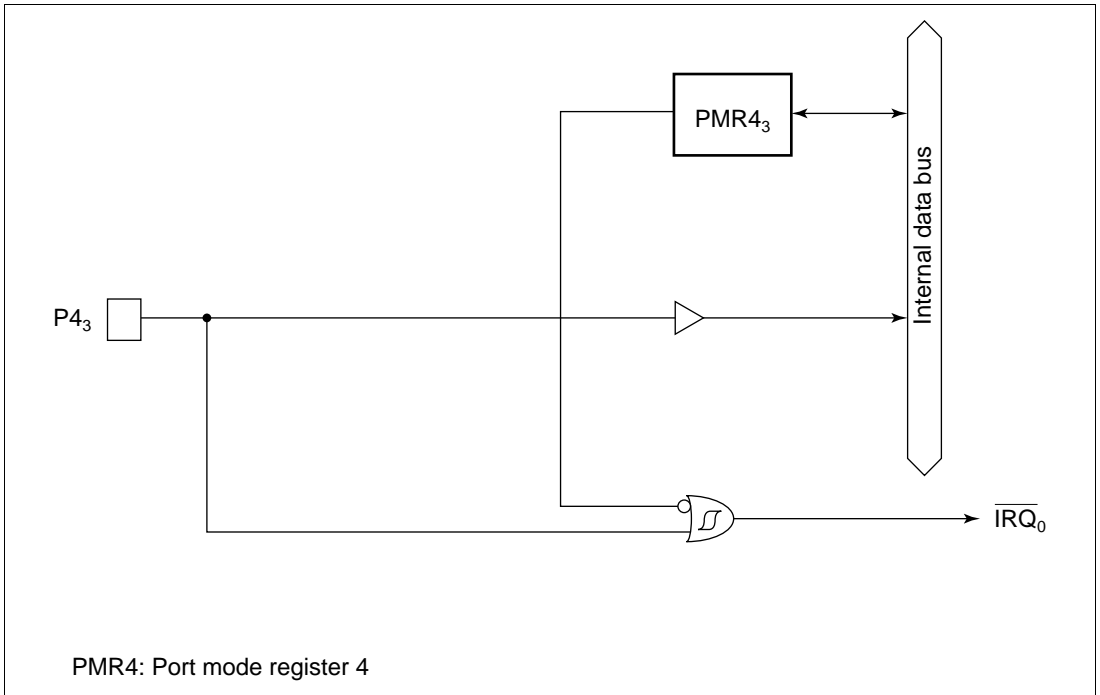

Figure C.3 (a) Port 4 Block Diagram (Pin P4₃)

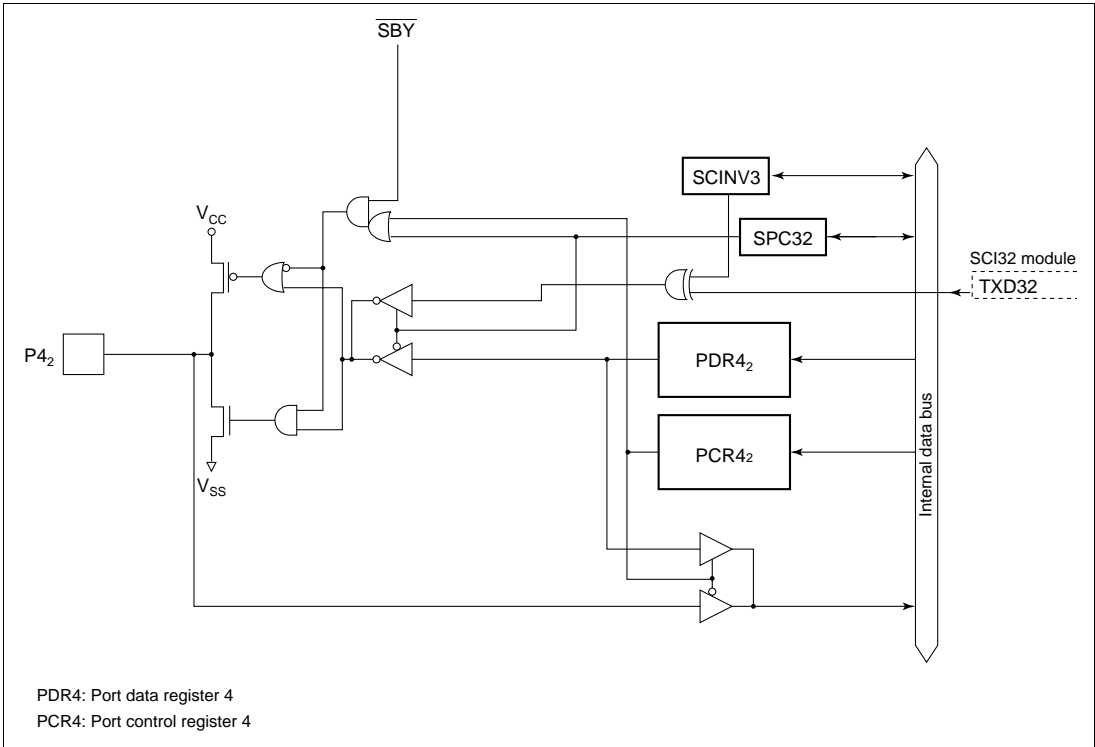

Figure C.3 (b) Port 4 Block Diagram (Pin P4₂)

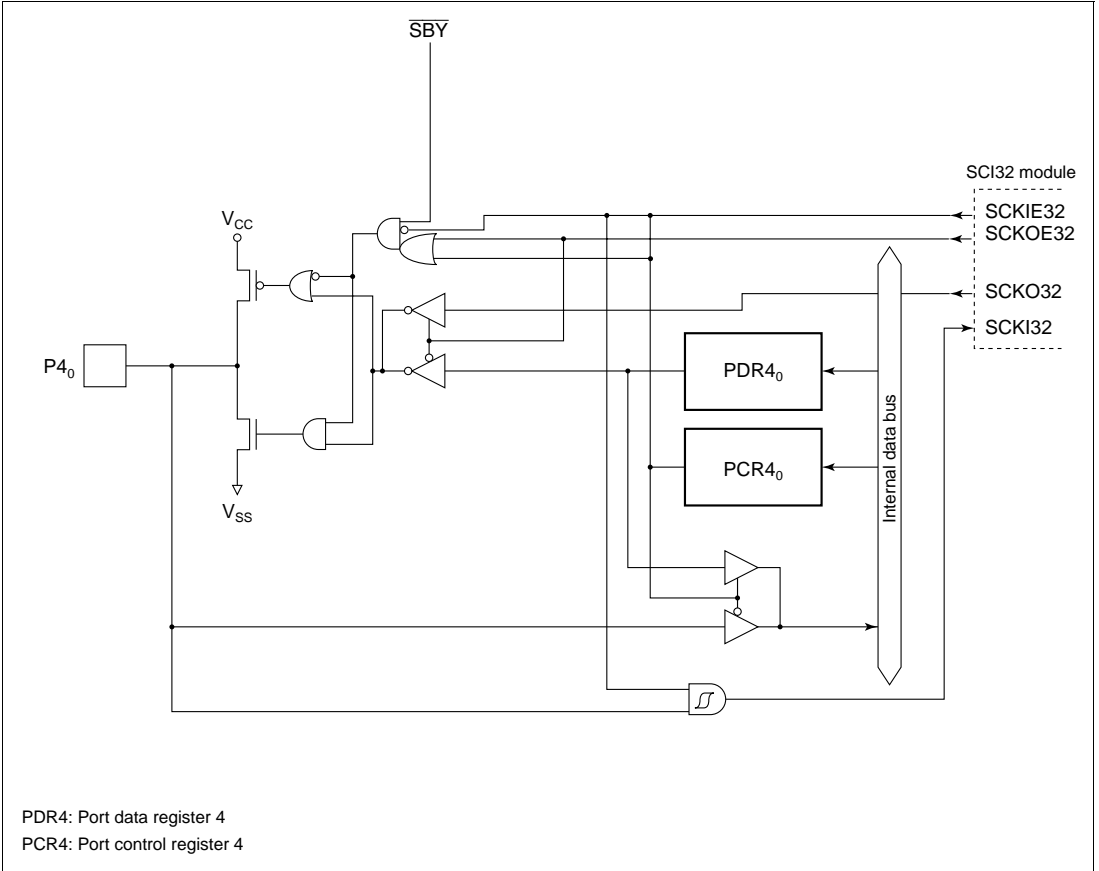

Figure C.3 (d) Port 4 Block Diagram (Pin P4₀)

C.6 Block Diagram of Port 7

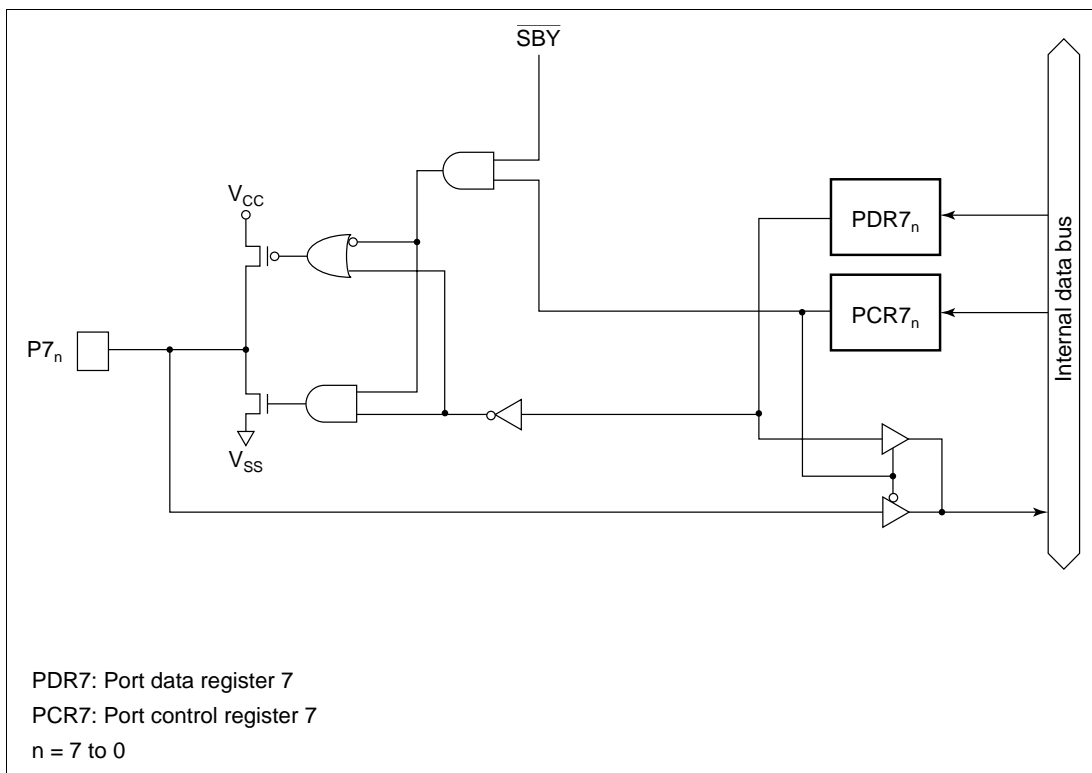

Figure C.6 Port 7 Block Diagram

C.8 Block Diagram of Port A

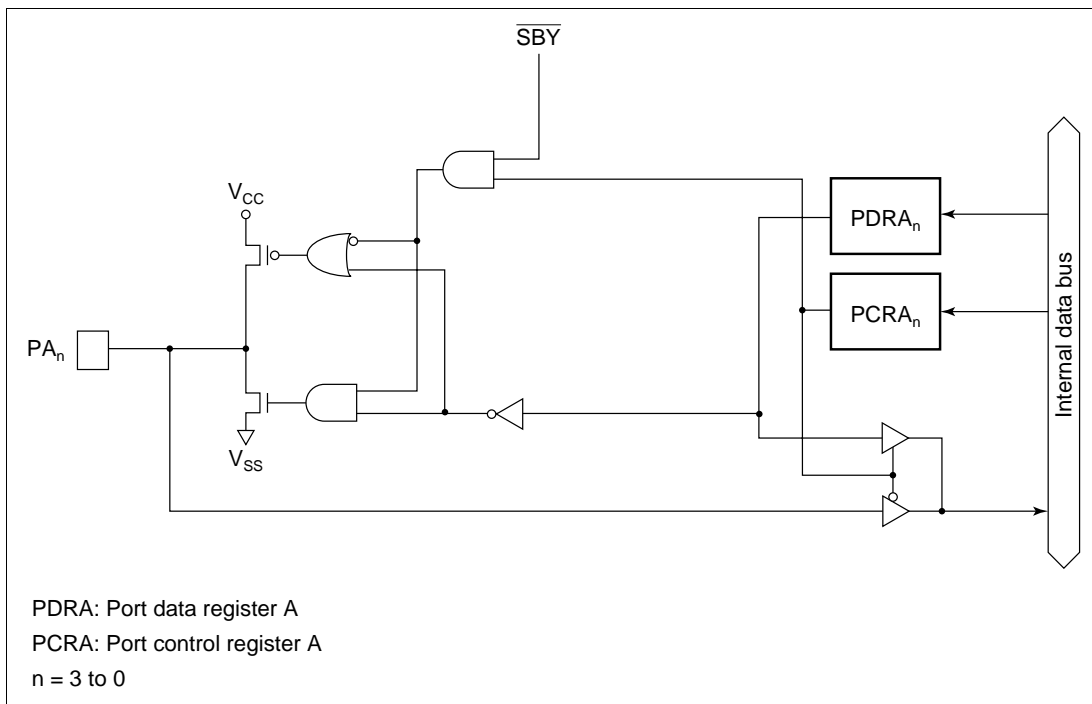

Figure C.8 Port A Block Diagram

C.9 Block Diagram of Port B

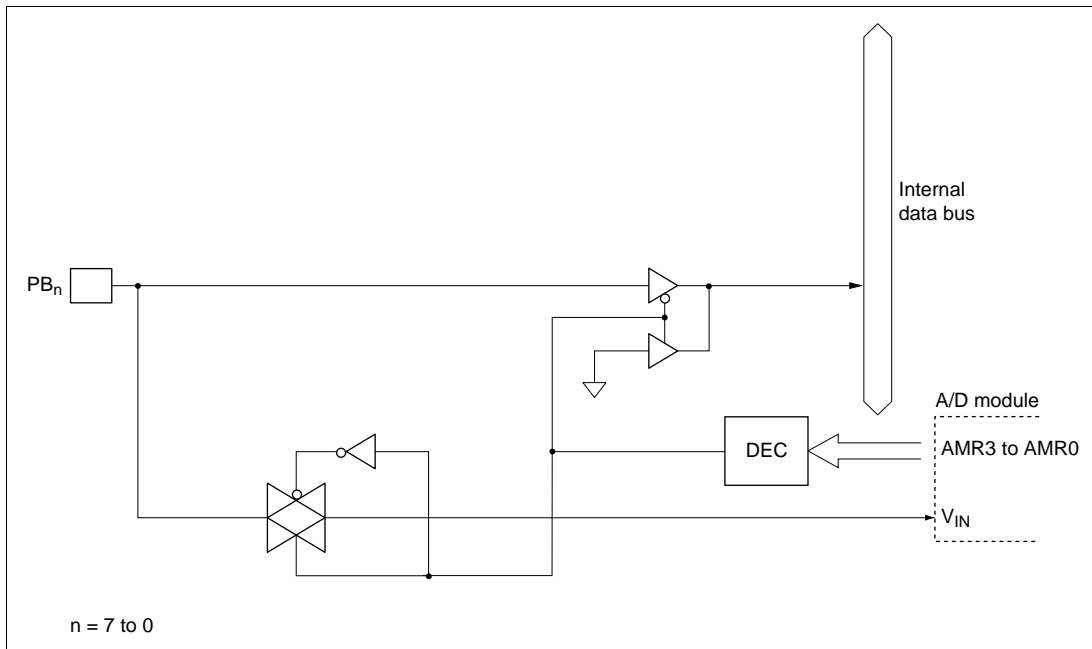

Figure C.9 Port B Block Diagram

Appendix D Port States in the Different Processing States

Table D.1 Port States Overview

| Port | Reset | Sleep | Subsleep | Standby | Watch | Subactive | Active |
|------------------------------------|------------------------------|----------------|----------------|------------------------------|----------------|----------------|----------------|
| P1 ₇ to P1 ₀ | High impedance | Retained | Retained | High impedance ^{*1} | Retained | Functions | Functions |
| P3 ₇ to P3 ₀ | High impedance ^{*2} | Retained | Retained | High impedance ^{*1} | Retained | Functions | Functions |
| P4 ₃ to P4 ₀ | High impedance | Retained | Retained | High impedance | Retained | Functions | Functions |
| P5 ₇ to P5 ₀ | High impedance | Retained | Retained | High impedance ^{*1} | Retained | Functions | Functions |
| P6 ₇ to P6 ₀ | High impedance | Retained | Retained | High impedance | Retained | Functions | Functions |
| P7 ₇ to P7 ₀ | High impedance | Retained | Retained | High impedance | Retained | Functions | Functions |
| P8 ₇ to P8 ₀ | High impedance | Retained | Retained | High impedance | Retained | Functions | Functions |
| PA ₃ to PA ₀ | High impedance | Retained | Retained | High impedance | Retained | Functions | Functions |
| PB ₇ to PB ₀ | High impedance | High impedance | High impedance | High impedance | High impedance | High impedance | High impedance |

Notes: 1. High level output when MOS pull-up is in on state.

2. P3₂ is Functions

Appendix E List of Product Codes

Table E.1 H8/3864 Series Product Code Lineup

| Product Type | | Product Code | Mark Code | Package (Hitachi Package Code) |
|-------------------|---------------------------------|--------------|-----------------|-----------------------------------|
| H8/3867 Series | H8/3862 Mask ROM versions | HD6433862H | HD6433862(***)H | 80 pin QFP (FP-80A) |
| | | HD6433862F | HD6433862(***)F | 80-pin QFP (FP-80B) |
| | | HD6433862W | HD6433862(***)W | 80-pin TQFP (TFP-80C) |
| H8/3863 | Mask ROM versions | HD6433863H | HD6433863(***)H | 80-pin QFP (FP-80A) |
| | | HD6433863F | HD6433863(***)F | 80-pin QFP (FP-80B) |
| | | HD6433863W | HD6433863(***)W | 80-pin TQFP (TFP-80C) |
| H8/3864 | Mask ROM versions | HD6433864H | HD6433864(***)H | 80-pin QFP (FP-80A) |
| | | HD6433864F | HD6433864(***)F | 80-pin QFP (FP-80B) |
| | | HD6433864W | HD6433864(***)W | 80-pin TQFP (TFP-80C) |
| H8/3865 | Mask ROM versions | HD6433865H | HD6433865(***)H | 80-pin QFP (FP-80A) |
| | | HD6433865F | HD6433865(***)F | 80-pin QFP (FP-80B) |
| | | HD6433865W | HD6433865(***)W | 80-pin TQFP (TFP-80C) |
| H8/3866 | Mask ROM versions | HD6433866H | HD6433866(***)H | 80-pin QFP (FP-80A) |
| | | HD6433866F | HD6433866(***)F | 80-pin QFP (FP-80B) |
| | | HD6433866W | HD6433866(***)W | 80-pin TQFP (TFP-80C) |
| H8/3867 | Mask ROM versions | HD6433867H | HD6433867(***)H | 80-pin QFP (FP-80A) |
| | | HD6433867F | HD6433867(***)F | 80-pin QFP (FP-80B) |
| | | HD6433867W | HD6433867(***)W | 80-pin TQFP (TFP-80C) |
| | ZTAT versions | HD6473867H | HD6473867H | 80-pin QFP (FP-80A) |
| | | HD6473867F | HD6473867F | 80-pin QFP (FP-80B) |
| | | HD6473867W | HD6473867W | 80-pin TQFP (TFP-80C) |

Note: For mask ROM versions, (***) is the ROM code.

Table E.1 H8/3864 Series Product Code Lineup (cont)

| Product Type | | | Product Code | Mark Code | Package (Hitachi Package Code) |
|-------------------|----------------------|----------------------|-----------------|-----------------------|-----------------------------------|
| H8/3827 Series | H8/3822 | Mask ROM versions | HD6433822H | HD6433822(***)H | 80-pin QFP (FP-80A) |
| | | | HD6433822F | HD6433822(***)F | 80-pin QFP (FP-80B) |
| | | | HD6433822W | HD6433822(***)W | 80-pin TQFP (TFP-80C) |
| | H8/3823 | Mask ROM versions | HD6433823H | HD6433823(***)H | 80-pin QFP (FP-80A) |
| | | | HD6433823F | HD6433823(***)F | 80-pin QFP (FP-80B) |
| | | | HD6433823W | HD6433823(***)W | 80-pin TQFP (TFP-80C) |
| | H8/3824 | Mask ROM versions | HD6433824H | HD6433824(***)H | 80-pin QFP (FP-80A) |
| | | | HD6433824F | HD6433824(***)F | 80-pin QFP (FP-80B) |
| | | | HD6433824W | HD6433824(***)W | 80-pin TQFP (TFP-80C) |
| H8/3825 | Mask ROM versions | HD6433825H | HD6433825(***)H | 80-pin QFP (FP-80A) | |
| | | HD6433825F | HD6433825(***)F | 80-pin QFP (FP-80B) | |
| | | HD6433825W | HD6433825(***)W | 80-pin TQFP (TFP-80C) | |
| H8/3826 | Mask ROM versions | HD6433826H | HD6433826(***)H | 80-pin QFP (FP-80A) | |
| | | HD6433826F | HD6433826(***)F | 80-pin QFP (FP-80B) | |
| | | HD6433826W | HD6433826(***)W | 80-pin TQFP (TFP-80C) | |
| H8/3827 | Mask ROM versions | HD6433827H | HD6433827(***)H | 80-pin QFP (FP-80A) | |
| | | HD6433827F | HD6433827(***)F | 80-pin QFP (FP-80B) | |
| | | HD6433827W | HD6433827(***)W | 80-pin TQFP (TFP-80C) | |
| | ZTAT versions | HD6473827H | HD6473827H | 80-pin QFP (FP-80A) | |
| | | HD6473827F | HD6473827F | 80-pin QFP (FP-80B) | |
| | | HD6473827W | HD6473827W | 80-pin TQFP (TFP-80C) | |

Note: For mask ROM versions, (***) is the ROM code.

Appendix F Package Dimensions

Dimensional drawings of H8/3867 and H8/3827 Series packages FP-80A, FP-80B and TFP-80C are shown in figures F.1, F.2 and F.3 below.

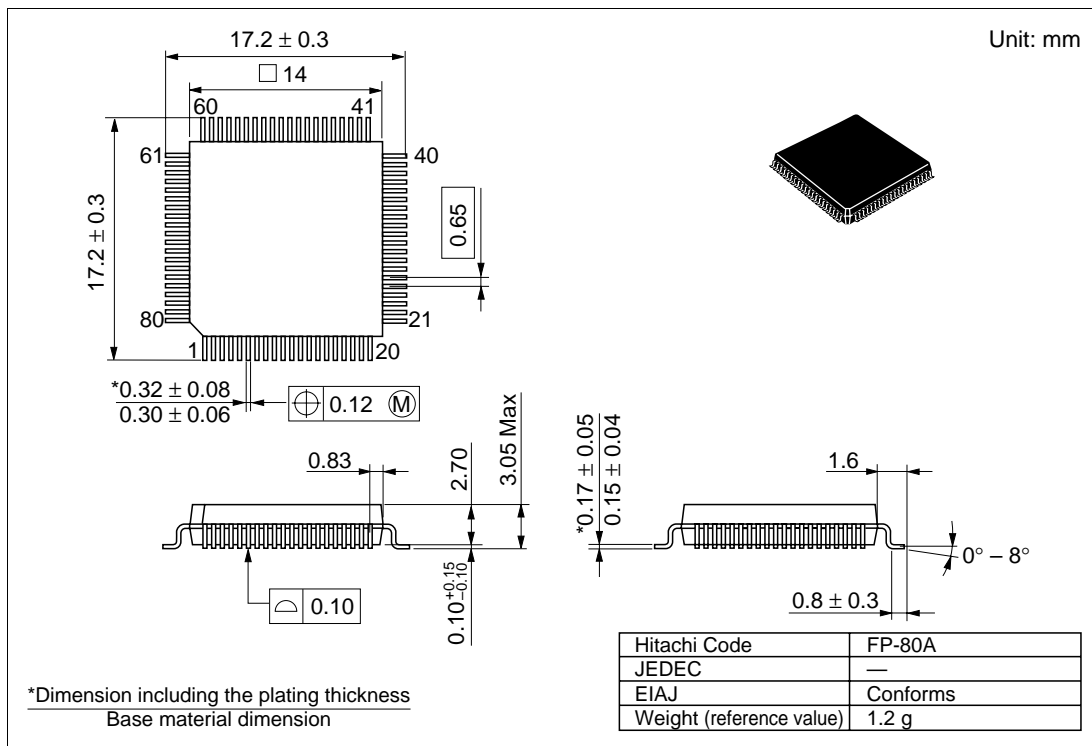
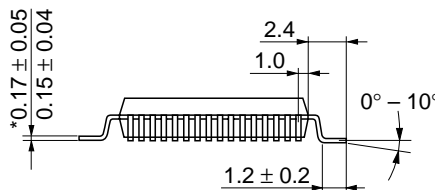
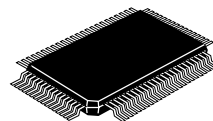
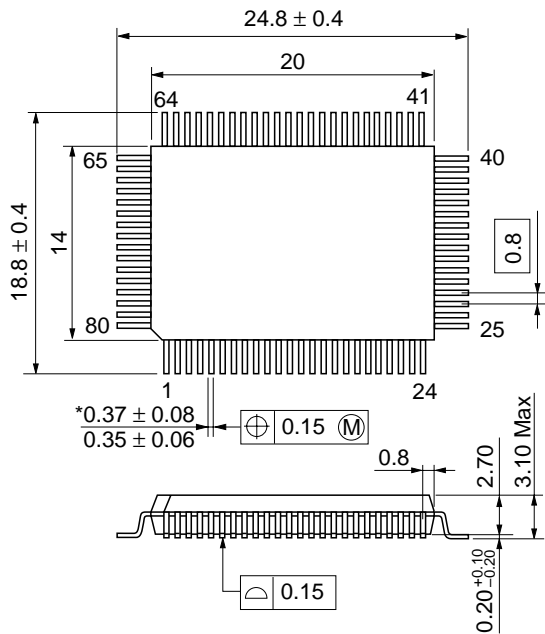

Figure F.1 FP-80A Package Dimensions

Unit: mm



| | |
|--------------------------|--------|
| Hitachi Code | FP-80B |
| JEDEC | — |
| EIAJ | — |
| Weight (reference value) | 1.7 g |

*Dimension including the plating thickness
Base material dimension

Figure F.2 FP-80B Package Dimensions

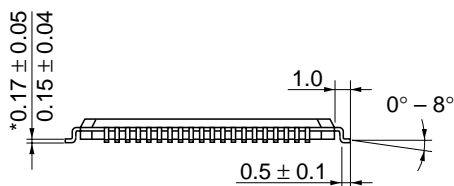
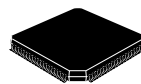
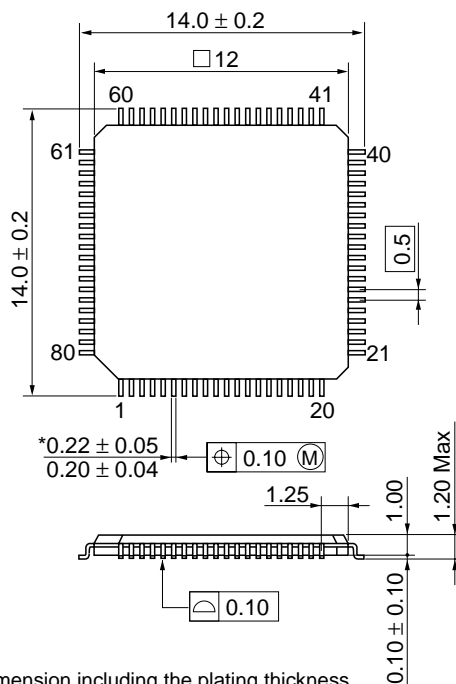

| | |
|--------------------------|----------|
| Hitachi Code | TFP-80C |
| JEDEC | — |
| EIAJ | Conforms |
| Weight (reference value) | 0.4 g |

*Dimension including the plating thickness
Base material dimension

Figure F.3 TFP-80C Package Dimensions

H8/3867 Series, H8/3827 Series Hardware Manual

Publication Date: 1st Edition, November 1997
3rd Edition, February 1999

Published by: Electronic Devices Sales & Marketing Group
Semiconductor & Integrated Circuits
Hitachi, Ltd.

Edited by: Technical Documentation Group
UL Media Co., Ltd.

Copyright © Hitachi, Ltd., 1997. All rights reserved. Printed in Japan.