

AMR4020, AMR4050

High Accuracy Analog Magnetic Scale Sensor

Description

The AMR40x0 series magnetic grate sensors integrate two push-pull Wheatstone bridges, each of which contains four high-sensitivity anisotropic magnetoresistance (AMR) sensing elements. Such a design effectively compensates temperature drift to ensure high accuracy under wide temperature range.

As the AMR40x0 moves along the magnetic scale, sensor outputs two orthogonal sets of analog voltage signals (sine and cosine), the period of which corresponds to the scale's magnetic pole pitch. The relative displacement of the sensor and the scale can be accurately determined by calculating the two sets of analog voltage signals. The AMR40x0 series have been designed with internal sensor elements close to the surface of the package to reduce limitations on airgap. Combined with the already small DFN12L (6 mm × 2 mm × 0.75 mm) package, the AMR40x0 series give greater responsibility to system design and ease of assembly in tight spaces.

Features and benefits

- Anisotropic magnetoresistance (AMR) technology
- Wide range supply voltages
- Large airgap tolerance
- Low saturation field
- Phase A and phase B analog output
- Excellent temperature stability
- High tolerance to external magnetic field interference
- RoHS & REACH compliant

Applications

- Incremental or absolute encoder
- Linear or angular displacement encoder
- Magnetic scale and magnetic encoder

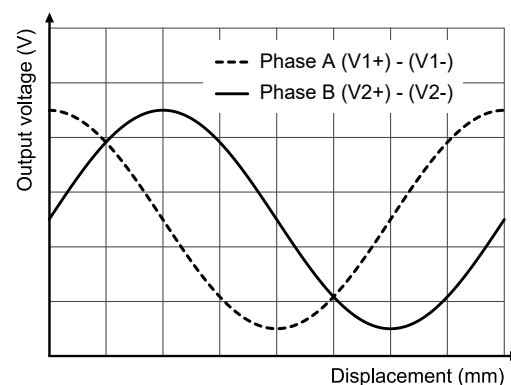
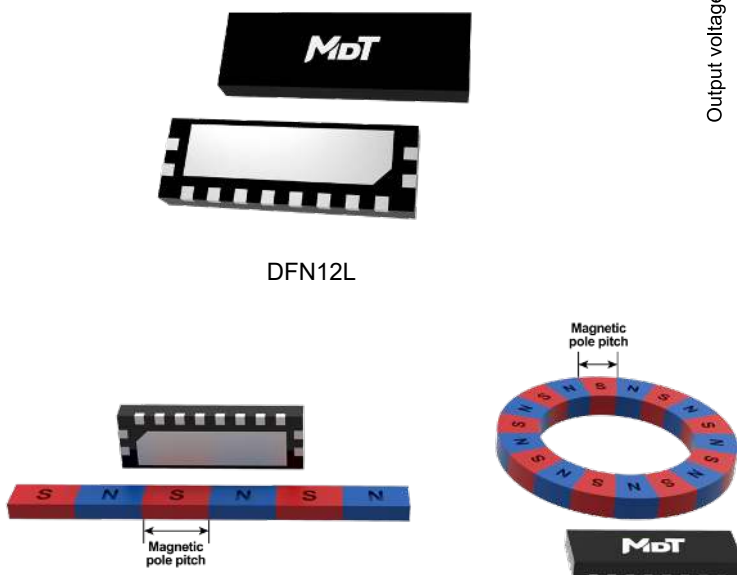

Selection Guide

Part Number	Magnetic Pole Pitch	Output Channel	Operating Ambient Temperature	Package	Packing Form
AMR4020D	2 mm	2	-40 °C to 125 °C	DFN12L	Tape & Reel
AMR4050D	5 mm	2	-40 °C to 125 °C	DFN12L	Tape & Reel

Catalogue

1. Functional Block Diagram.....	03
2. Application schematics	03
3. Pin Configuration	04
4. Absolute Maximum Ratings	05
5. Electrical Specifications.....	05
6. Application Information	06
6.1 Application and Output Voltage Amplitude	06
6.2 Installation Requirements and Measurement Accuracy	06
7. Dimensions.....	07

1. Functional Block Diagram

The AMR40x0 series sensors are designed with AMR resistors in Wheatstone bridges, improving the sensor's output signal amplitude and enhancing the sensor's temperature stability. The sensors' electrical connections are shown in Figure 1.

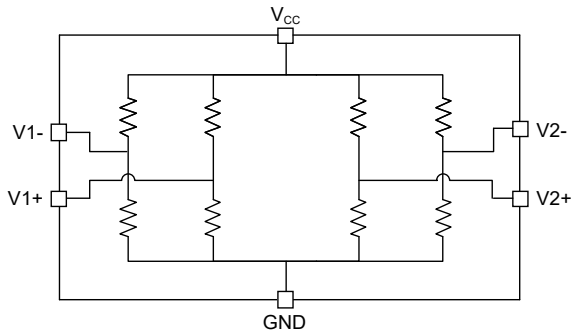

Figure 1-1. Block diagram (AMR4020D)

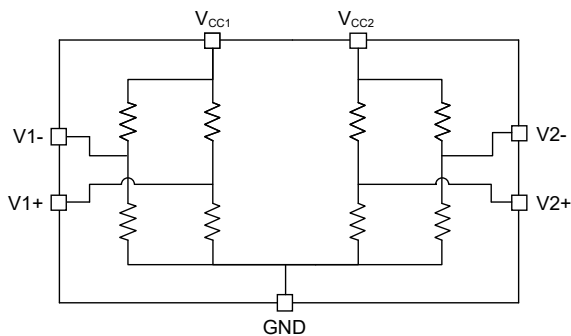

Figure 1-2. Block diagram (AMR4050D)

thus each output sinusoidal signals with a phase difference of 90° ($1/4$ of period). The direction and length of displacement of the applied magnetic field at any time can be obtained by combining the two signals.

Each output signal (V1 or V2) is a differential analog signal, and each signal consists of two pin outputs as shown in the table of pin configuration section.

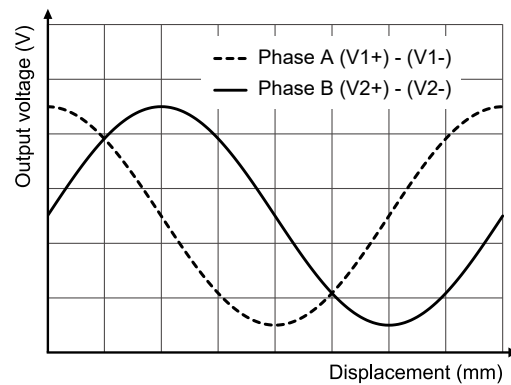

Figure 3. Schematic of output voltage when moving along the length of the magnetic scale

2. Application schematics

The AMR40x0 series sensors respond to horizontal magnetic field (X-Y plane) as shown in Figure 2.



Figure 2. Sensing direction

When the AMR40x0 series is in a magnetic field, the internal AMR sensor elements will exhibit change in resistance in response to magnetic field displacement. The two Wheatstone bridges will

3. Pin Configuration

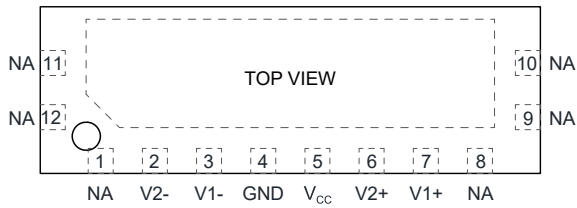

Figure 4-1. Pin configuration of AMR4020 (DFN12L)

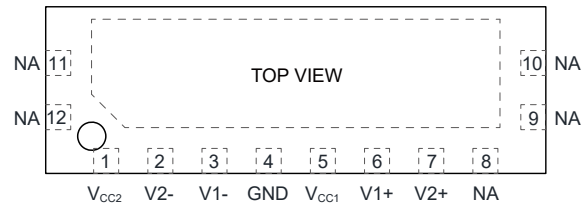

Figure 4-2. Pin configuration of AMR4050 (DFN12L)

Table 1. The AMR4020D pin configuration

Number	Symbol	Function
1	NA	-
2	V2-	Phase B signal negative output
3	V1-	Phase A signal negative output
4	GND	Ground
5	V _{CC}	Power supply
6	V2+	Phase B signal positive output
7	V1+	Phase A signal positive output
8	NA	-
9	NA	[1]
10	NA	-
11	NA	-
12	NA	[1]
-	EP	Heat dissipation

Table 2. The AMR4050D pin configuration

Number	Symbol	Function
1	V _{CC2}	Phase B power supply
2	V2-	Phase B signal negative output
3	V1-	Phase A signal negative output
4	GND	Ground
5	V _{CC1}	Phase A power supply
6	V1+	Phase A signal positive output
7	V2+	Phase B signal positive output
8	NA	-
9	NA	[1]
10	NA	-
11	NA	-
12	NA	[1]
-	EP	Heat dissipation

Note: Pin 9, pin 12 and EP are connected inside the sensor.

4. Absolute Maximum Ratings

Parameters	Symbol	Min.	Max.	Unit	Applicable Part Number
Supply voltage	V_{CC}	-9	9	V	All parts
Magnetic flux density	B	-	1500	Gs ¹⁾	All parts
Operating ambient temperature	T_A	-40	125	°C	All parts
Storage ambient temperature	T_{STG}	-40	150	°C	All parts

5. Electrical Specifications

$V_{CC} = 5\text{ V}$, $T_A = 25\text{ °C}$, a 0.1 μF capacitor is connected between V_{CC} and GND

Parameter	Symbol	Condition	Min.	Typ.	Max.	Unit	Applicable Part Number
Supply voltage	V_{CC}	Operating	-	5	9	V	All parts
Bridge resistance ²⁾	R_B	B = 0 Gs, $T_A = 25\text{ °C}$	-	2.8	-	k Ω	AMR4020D
			-	2.4	-	k Ω	AMR4050D
Temperature coefficient of bridge resistance ³⁾	TCR_B	$T_1 = -40\text{ °C}$, $T_2 = +125\text{ °C}$	-	0.23	-	%/°C	All parts
Output amplitude ⁴⁾	V_{PEAK}	$V_{CC} = 5\text{ V}$, $T_A = 25\text{ °C}$	9	11	13	mV/V	All parts
Temperature coefficient of output amplitude ⁵⁾	TCV_{PEAK}	$T_1 = -40\text{ °C}$, $T_2 = +125\text{ °C}$	-	-0.4	-	%/°C	All parts
Offset ⁶⁾	V_{OFFSET}	$V_{CC} = 5\text{ V}$, $T_A = 25\text{ °C}$	-1	0	+1	mV/V	All parts
Temperature coefficient of offset ⁷⁾	TCO	$T_1 = -40\text{ °C}$, $T_2 = +125\text{ °C}$	-5	0	+5	$\mu\text{V/V/°C}$	All parts

Note:

- 1 Gauss in air = 0.1 millitesla = 79.8 A/m
- 2) Resistance between V1+ and V1-. Resistance between V2+ and V2-. Resistances can be customized upon request.

$$3) \quad TCR_B = \frac{R_B(T_2) - R_B(T_1)}{R_B(T_1) \times (T_2 - T_1)} \times 100\%$$

$$4) \quad V_{PEAK} = \frac{V_{MAX} - V_{MIN}}{2}$$

$$5) \quad TCV_{PEAK} = \frac{V_{PEAK}(T_2) - V_{PEAK}(T_1)}{V_{PEAK}(T_1) \times (T_2 - T_1)} \times 100\%$$

$$6) \quad V_{OFFSET} = \frac{V_{MAX} + V_{MIN}}{2}$$

$$7) \quad TCO = \frac{V_{OFF}(T_2) - V_{OFF}(T_1)}{T_2 - T_1}$$

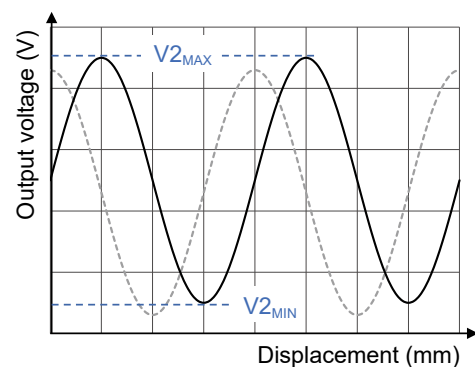

6. Application Information

6.1 Application and Output Voltage Amplitude

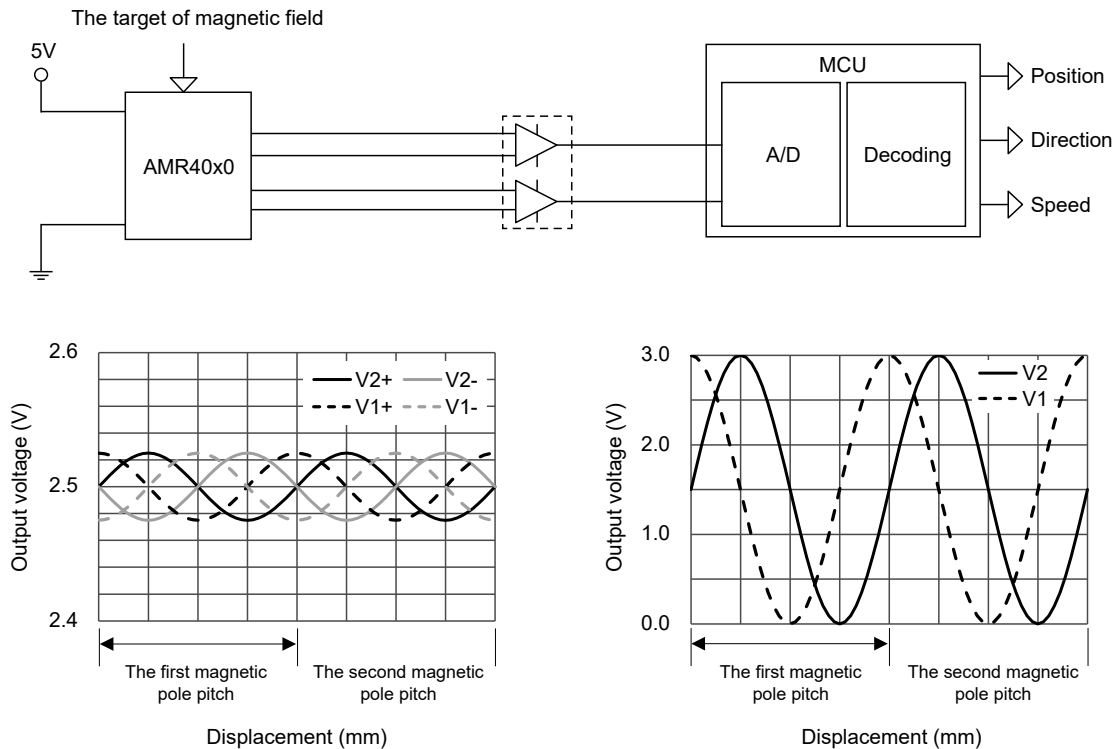

Figure 5. Operational amplifier that converts signal from single channel differential output signal to differential and adjust amplitude to input to A/D

6.2 Installation Requirements and Measurement Accuracy

To ensure signal quality, the sensor usually needs to be installed within an acceptable airgap (airgap < 50 % of magnetic pole pitch) such that the internal AMR sensor elements operate in a saturated field (magnetic field at sensor surface ≥ 200 Gs).

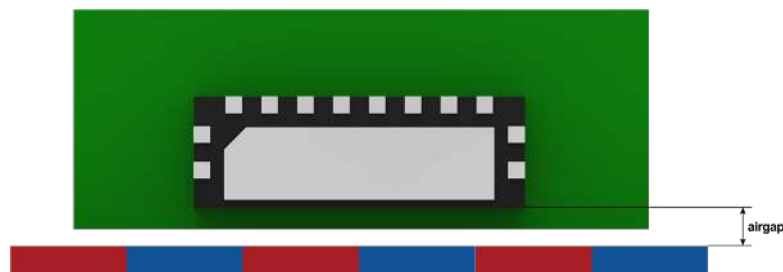

Figure 6. Relative position of the AMR40x0 and magnetic scale

When properly installed, changes to airgap during operation will not affect the quality of the output signal. The measurement accuracy of the solution closely depends on factors including accuracy of the magnetic scale, magnetic pole pitch, installation and operating conditions, and analog signal processing. Usually, absolute accuracy of 10 μm to 50 μm is a realistic goal for system design.

7. Dimensions

DFN12L Package - AMR4020

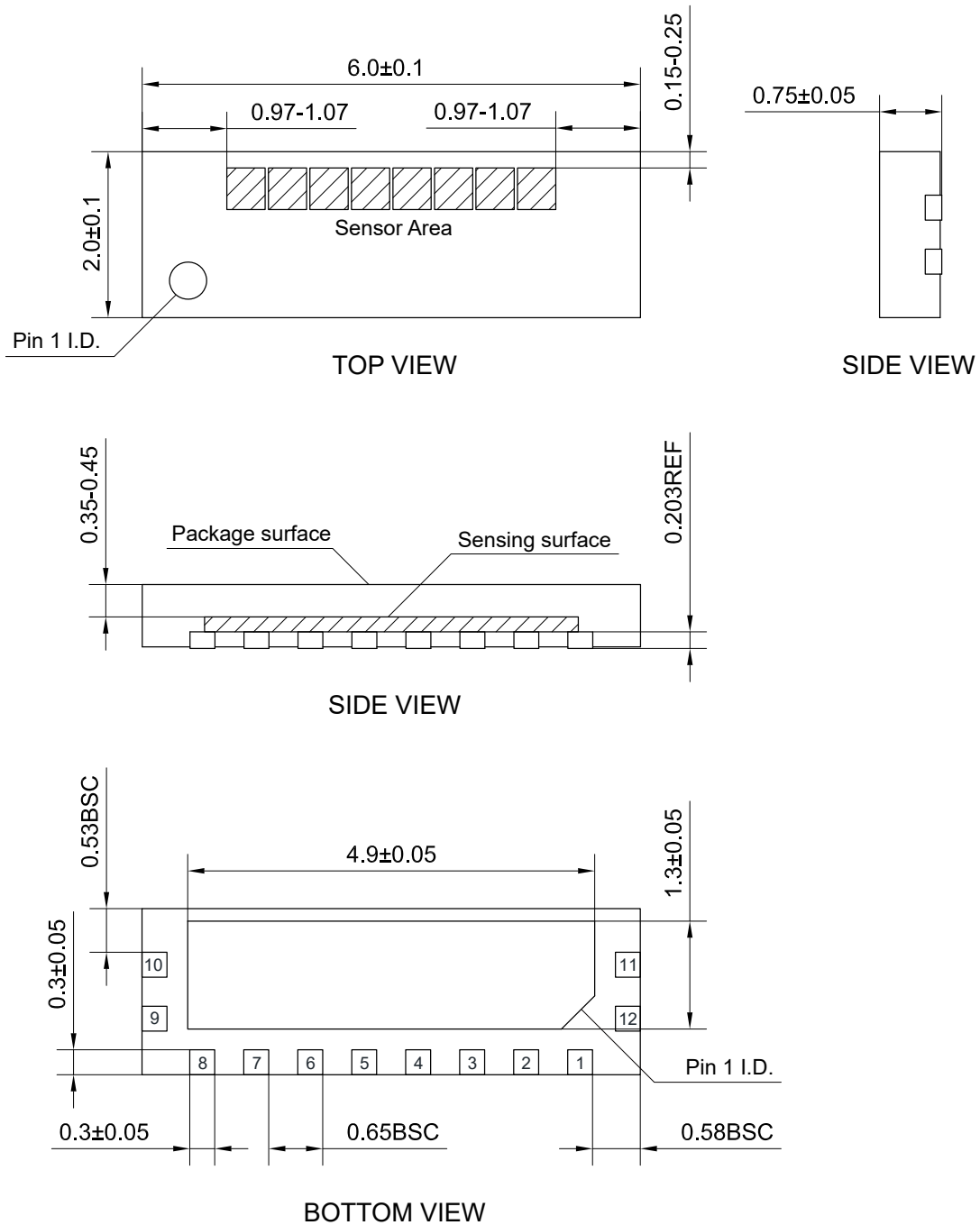

Figure 7. DFN12L package outline of AMR4020 (unit: mm)

DFN12L Package - AMR4050

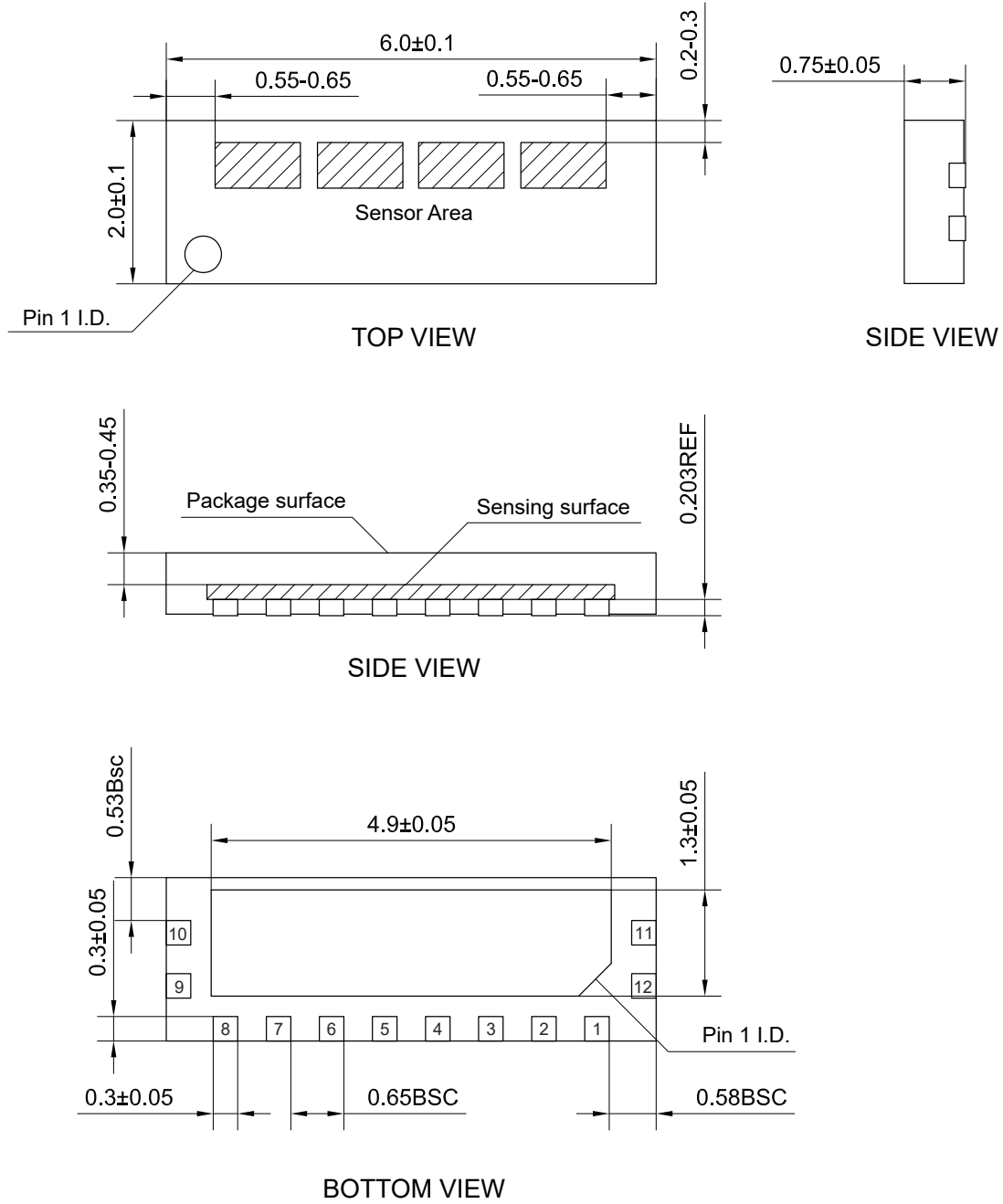

Figure 8. DFN12L package outline of AMR4050 (unit: mm)

Copyright © 2022 by MultiDimension Technology Co., Ltd.

Information furnished herein by MultiDimension Technology Co., Ltd. (hereinafter MDT) is believed to be accurate and reliable. However, MDT disclaims any and all warranties and liabilities of any kind, with respect to any examples, hints or any performance or use of technical data as described herein and/or any information regarding the application of the product, including without limitation warranties of non-infringement of intellectual property rights of any third party. This document neither conveys nor implies any license under patent or other industrial or intellectual property rights. Customer or any third-party must further determine the suitability of the MDT products for its applications to avoid the applications default of customer or third-party. MDT accept no liability in this respect.

MDT does not assume any liabilities of any indirect, incidental, punitive, special or consequential damages (including without limitation of lost profits, lost savings, business interruption, costs related to the removal or replacement of any products or rework charges) whether or not such damages are based on tort (including negligence), warranty, breach of contract or any other legal theory. Notwithstanding any damages that customer might incur for any reason whatsoever, MDT's aggregate and cumulative liability towards customer for the products described herein shall be limited in accordance with the terms and conditions of commercial sale of MDT.

Absolute maximum ratings are the extreme limits the device will withstand without damage to the MDT product. However, the electrical and mechanical characteristics are not guaranteed as the maximum limits (above recommended operating conditions) are approached. MDT disclaims any and all warranties and liabilities of the MDT product will operate at absolute maximum ratings.

Specifications may change without notice.

Please download latest document from our official website www.dowaytech.com/en.

Recycling

The product(s) in this document need to be handed over to a qualified solid waste management services company for recycling in accordance with relevant regulations on waste classification after the end of the product(s) life.



No.2 Guangdong Road, Zhangjiagang Free Trade Zone, Jiangsu, China

Web: www.dowaytech.com/en E-mail: info@dowaytech.com

