

## Description

The Z-321NFW-50 is a small in-line filter designed to expedite the service delivery and improve the performance of digital subscriber line (DSL) services. This model filters all telephone sets, facsimile machines, answering machines, etc. individually or in groups. This in-line DSL filter design electronically isolates the high-speed DSL data streams from the voice band plain old telephone service (POTS) equipment. This design effectively blocks the DSL, and other radio frequencies from 25 kilohertz to 30 Megahertz.

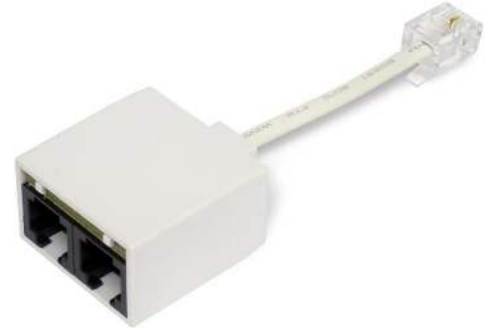

*The in-line DSL nanoFILTER*

## Features

- **Data Protection** - Isolates telephone impedances changes from DSL equipment
- Excellent DSL band attenuation that protects voice band equipment and prevents intermodulation distortion from degrading data rates
- Compatible with all major DSL standards including ADSL, ADSL2+, VDSL, and VDSL2
- **Voice Protection** - Isolates DSL band frequencies from voice band equipment
- Excellent longitudinal balance
- Compatible with Caller ID, facsimile and metallic loop testing
- RoHS compliant
- CE Certified
- Compliant with UL 60950, and FCC Part 68

## Applications

The Z-321NFW-50 filters are used with other Z-BLOCKER filters distributed throughout the subscribers' premises to isolate all voice band equipment devices such as cordless telephones, answering machines, fax machines, dial-up modems, and television set-top boxes.

The Z-321NFW-50 in-line DSL filter is one of many filters manufactured by Pulse for subscriber installed digital services within homes, offices, and hotels. Excelsus is the number one selling brand of DSL filters worldwide.

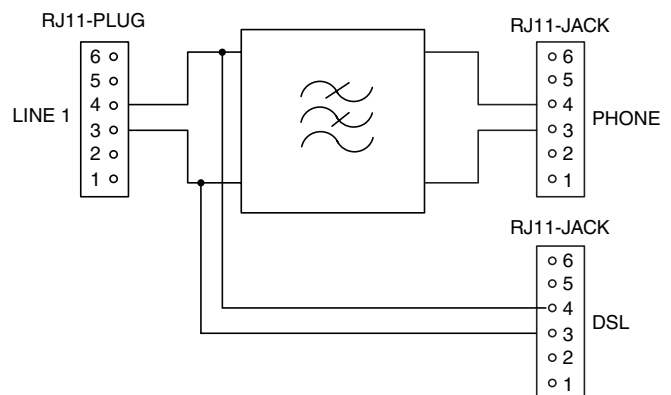

*Z-321NFW-50 Block Schematic*

## NanoFilter Z-321NFW-50 Specifications

Line side differential input blocking impedance		
At 20 kHz		>2 k
At 30 kHz		>3 k
From 5 MHz to 10 MHz		
1 kHz insertion loss between 600 Ω resistive		<0.2 dB
1 kHz/2.8 kHz slope between 600 Ω resistive		
Single filter		<0.1 dB
With 3 filters		<1.1 dB
DC resistance in Ohms		
Tip to Tip, and Ring to Ring		<12 Ω
Tip to Ring		>10 Ω
Longitudinal Balance per IEEE method		
From 200 - 1 kHz		>58 dB
From 1 kHz - 3 kHz		>53 dB
xDSL Insertion Loss (with ZDSL)		
	25 kHz	≥16 dB
	40 kHz	≥25 dB
	1.1 MHz	≥70 dB
	2.2 MHz	≥70 dB
	30 MHz	≥55 dB
Low pass roll off (slope) between 600 Ω and ADSL Transmission Unit - Remote		>26 dB
Inter-Modulation Distortion First and Second order products		>60 dB
Envelope Delay 300 Hz - 2800 Hz		<100 μs
600 Ω POTS Return Loss (with ZADSL)		
Single filter	SRL Low	>30 dB
	ERL	>18 dB
	SRL High	>14 dB
+2 bridged filters	SRL Low	>18 dB
	ERL	>13 dB
	SRL High	>8 dB
Connectors: RJ-11 Jacks and RJ11 Plug		
50 micro-inches of gold plating over ≥100 micro-inches of nickel plating		
Compliant and listed with UL / CSA 60950, FCC CFR 47 Part 68		

## Mechanical specifications

