

THIS DRAWING IS UNPUBLISHED. RELEASED FOR PUBLICATION 20
 © COPYRIGHT 20 BY - ALL RIGHTS RESERVED.

LOC	DIST	REVISIONS			
P	LTR	DESCRIPTION	DATE	DWN	APVD
AF	-	A	REVISED PER ECR-13-018775	11DEC2013	KH KR

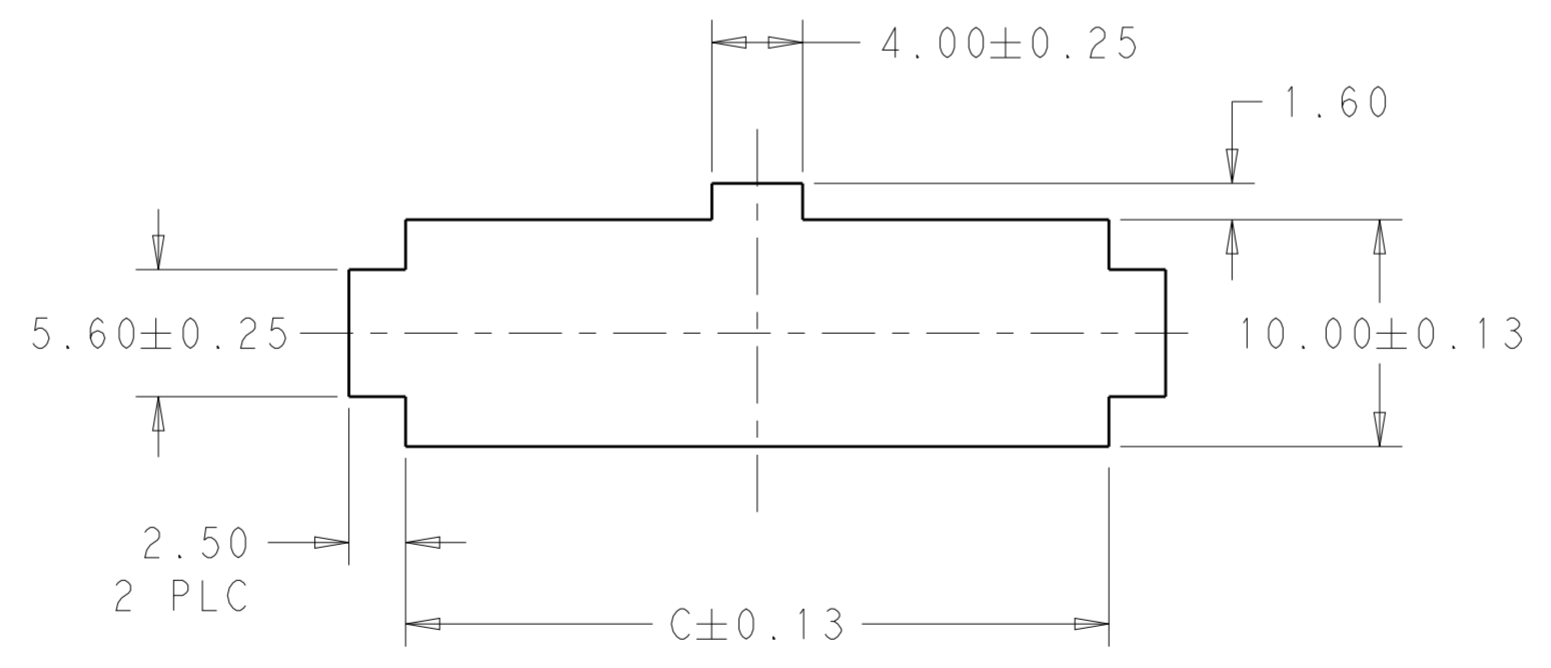
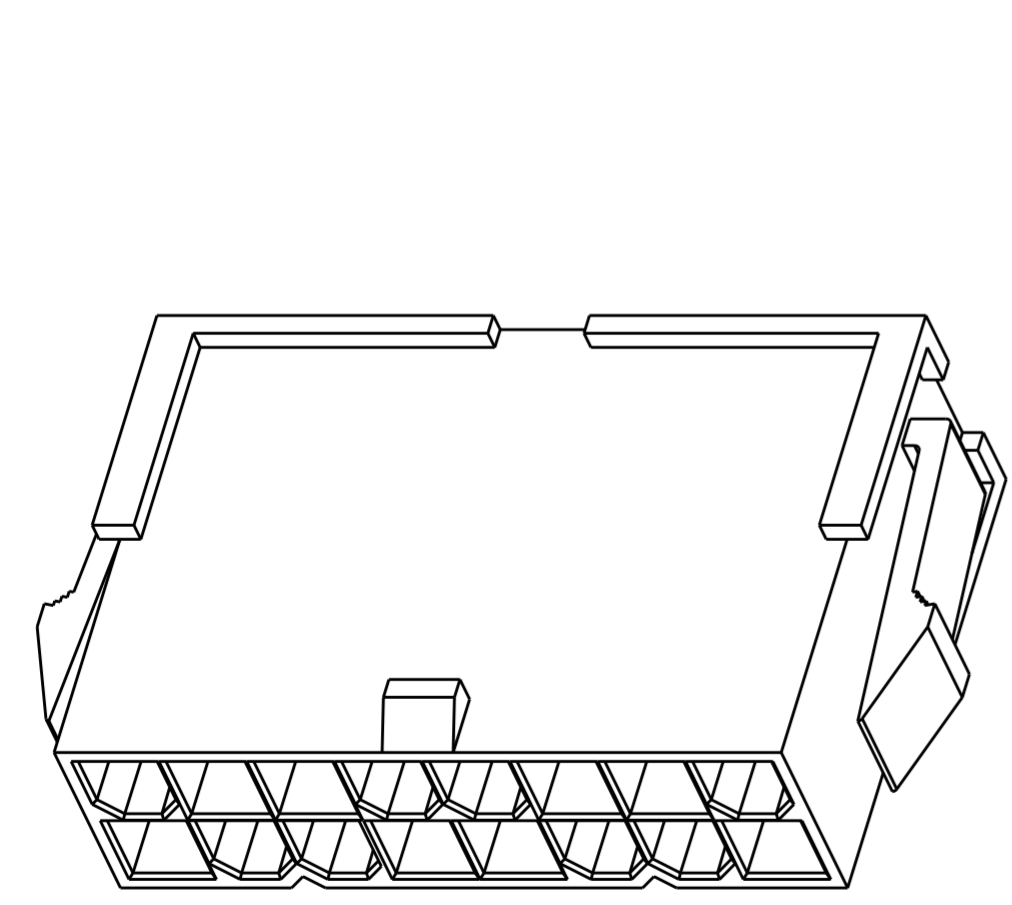
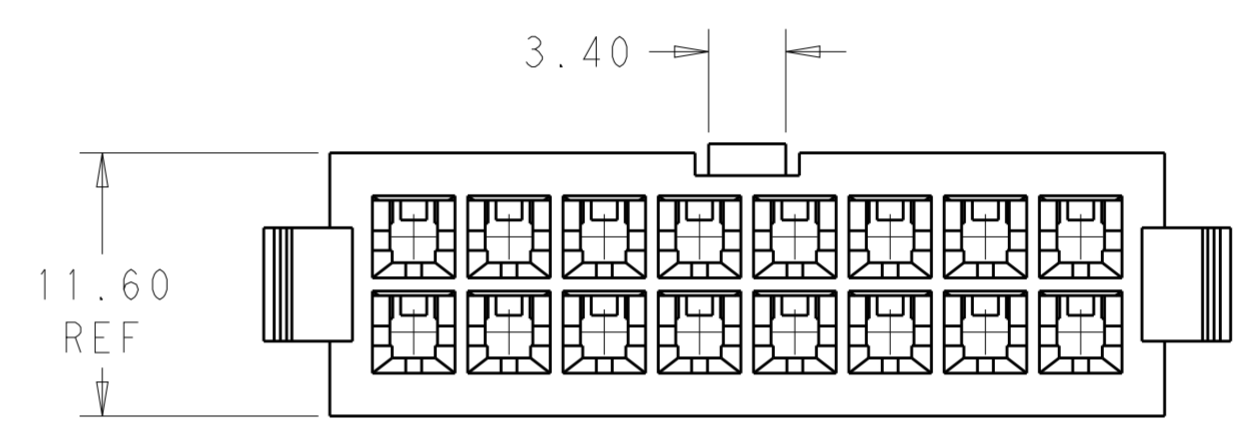
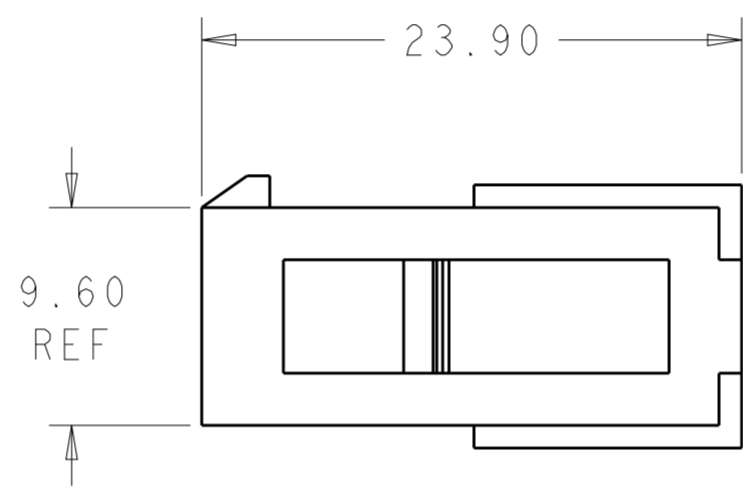
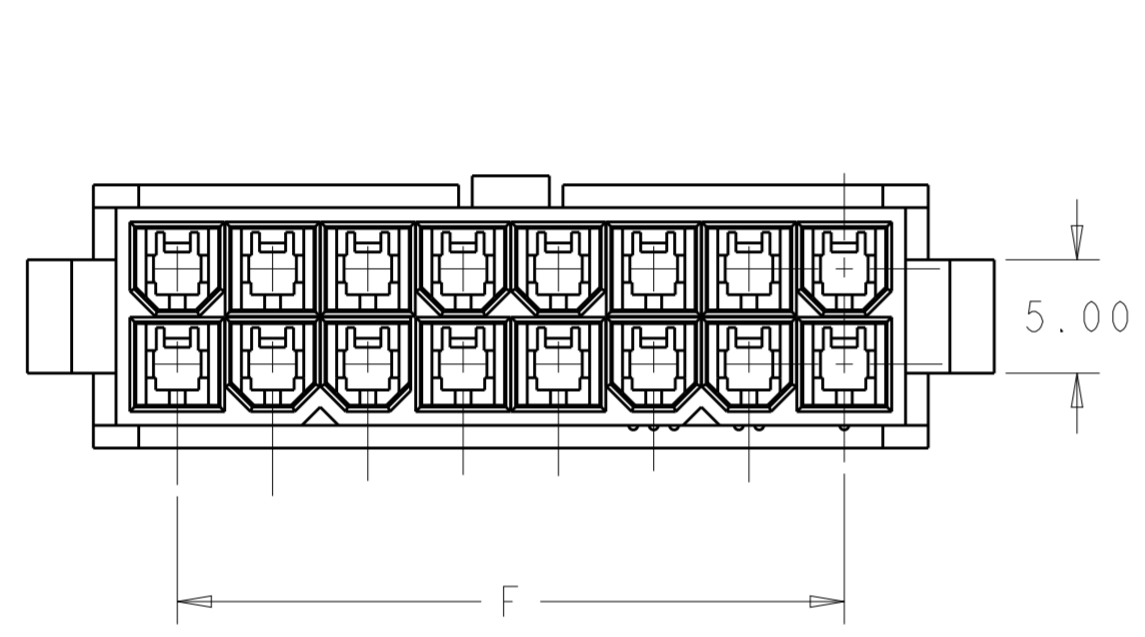
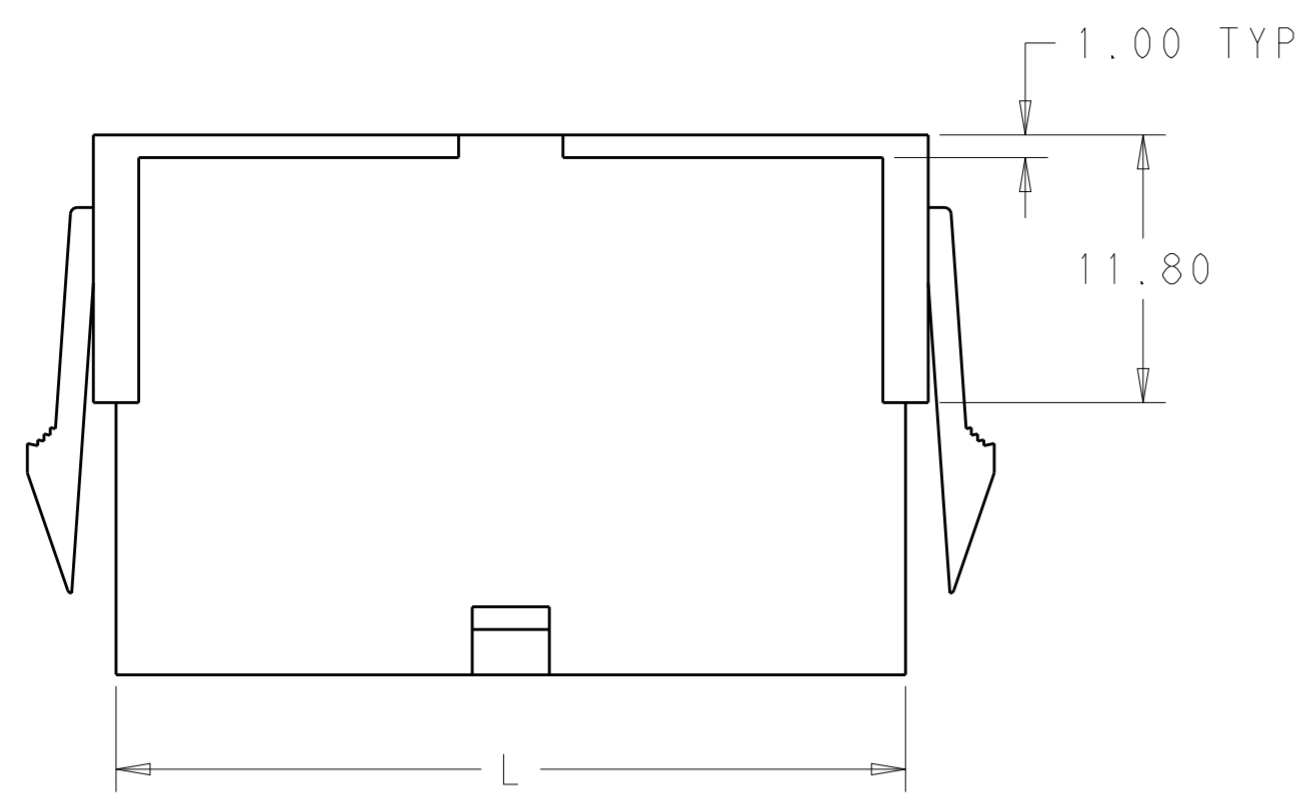

RECOMMENDED CUT-OUT FOR
2.00 MAX THICK PANEL

PANEL MUST BE PUNCHED OUT SO THAT THE
HOUSING ENTERS THE PANEL IN THE
SAME DIRECTION AS THE PUNCH.

52.00	46.2	51.60	24	2-1969599-4
47.80	42.0	47.40	22	2-1969599-2
43.60	37.8	43.20	20	2-1969599-0
39.40	33.6	39.00	18	1-1969599-8
35.20	29.4	34.80	16	1-1969599-6
31.00	25.2	30.60	14	1-1969599-4
26.80	21.0	26.40	12	1-1969599-2
22.60	16.8	22.20	10	1-1969599-0
18.40	12.6	18.00	8	1969599-8
14.20	8.4	13.80	6	1969599-6
10.00	4.2	9.60	4	1969599-4
5.80	--	5.40	2	1969599-2
DIM C	DIM F	DIM L	NO. OF POS	PART NO.

THIS DRAWING IS A CONTROLLED DOCUMENT.		DWN JR RUTH 12DEC2012	TE Connectivity					
DIMENSIONS: mm		CHK KURT RANDOLPH 12DEC2012						
TOLERANCES UNLESS OTHERWISE SPECIFIED:		APVD KURT RANDOLPH 12DEC2012						
0 PLC ± 1 PLC ± 2 PLC ±0.25 3 PLC ± 4 PLC ± ANGLES ± FINISH ±		NAME PANEL MOUNT PLUG HOUSING VAL-U-LOK						
MATERIAL NYLON 6/6, V2	COLOR-NATURAL	PRODUCT SPEC -	APPLICATION SPEC -	WEIGHT -	SIZE A200779	CAGE CODE C-1969599	DRAWING NO -	RESTRICTED TO -
Customer Drawing					SCALE 3:1	SHEET 1	OF 1	REV A