

BCM53162

Ultra-Low Power TSN 1GbE/2.5GbE Switch with 10GbE Uplinks for Automotive 2.0

Description

From the Broadcom® RoboSwitch™-2 BCM5316X family, the BCM53162 is a multi-gigabit 1GbE/2.5GbE switch with 10GbE uplinks that meets the requirements of the new Automotive 2.0 market. This new market encompasses the technology and business shifts associated with the transition from human-controlled to autonomous driving. As part of this shift, the In-Vehicle Network (IVN) is expected to grow in bandwidth and transition from 100MbE to multi-GbE and multi-10GbE connectivity in at least two vehicle domains: Advanced Driver Assistance System (ADAS) and backbone.

Next-generation ADAS is the main vehicle domain that will enable autonomous driving. It includes a large set of sensors, radars, cameras, and one or more processors that analyzes the fused data inputs and decides driving operations (steering, braking, speeding, and so on). The new data inputs require GbE or multi-GbE connectivity, which results in 10GbE connectivity to the processors. Similar to progress in ADAS networks, the next-generation automotive backbone is based on high-bandwidth 1GbE/2.5GbE/10GbE links in ring, star, or full-mesh topologies. Figure 1 illustrates the architecture of a common ADAS and backbone.

The BCM53162 supports four 1GbE/2.5GbE SGMII ports, one 1GbE RGMII port, two 10GE XFI/SFI ports, and an additional eight 1GbE PHYs. The eight PHYs can be converted to SGMII ports by placement of external PHYs^[1]. The SGMII ports on the switch (the original four and the new eight) enable the placement of the automotive 1000BASE-T1, BroadR-Reach® technology, and PHYs.

Despite its high-bandwidth support, the BCM53162 can meet the power requirements of future electric vehicles; it is extremely power efficient and consumes no more than 4.5W. Similar to other members of the BCM5316X family, the BCM53162 integrates a powerful ARM Cortex-M7 CPU, a high-end forwarding engine with Virtual Switching Instance (VSI) support, an advanced Quality-of-Service (QoS) engine, a flexible Content Filter Processor (CFP), security features, and much more.

Figure 1: Automotive 2.0 ADAS and Backbone

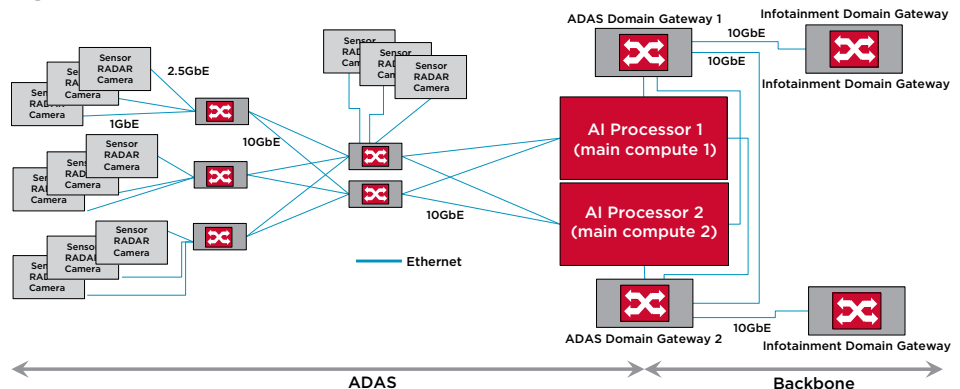

Key Features

- Four 1GbE/2.5GbE SGMII+ ports
- Two 2.5GbE/10GbE XFI/SFI ports
- One 1GbE RGMII port
- Eight 100/1000BASE-T ports connecting to external
- An integrated ARM Cortex-M7 CPU
- An RGMII, MII, and RvMII port to connect to an external CPU (or to be used as a 1GbE customer port)
- Cascading capability for creating a 14- to 26-port switch such as 2x 10GbE XFI + 8x 1GE/2.5GbE SGMII
- Support for Time-Sensitive Networking (TSN) feature set with accurate clocking
- Power-saving green technology per IEEE 802.3az Energy Efficient Ethernet
- Support for industrial temperature grade (-40°C to +85°C)
- Automotive In-Vehicle Infotainment (IVI) qualified^[2]

Applications

- Next-generation ADAS
- Next-generation automotive backbone
- Next-generation drones and robots
- Enterprise 2.5GbE backbone solution
- Industrial automation switches



For Automotive 2.0 specifically, the BCM53162 supports a TSN and Synchronization feature set such as IEEE 802.1Qav (AVB), IEEE 802.1Qbv (TAS), IEEE 802.1Qci, IEEE 1588v2, IEEE 802.1AS, Synchronized Ethernet (SyncE) per ITU-T G.8261/2, and more. The BCM53162 is offered to customers in a small 19 mm × 19 mm package for an industrial temperature grade.

Benefits

- Supports 2× 2.5GbE/10GbE XFI/SFI + 4× 1GbE/2.5GbE SGMII + 8× 100/1000BASE-T GPHY + 1× 1GbE RGMII with ultra-low power consumption that fits expected Automotive 2.0 electric car requirements.
- Advanced TSN support such as IEEE 802.1Qav, 802.1Qbv, and 802.1Qci for scheduling time-critical traffic streams across the IVN.
- Advanced clock synchronization support including IEEE 1588v2 Master, Slave, Transparent, and Boundary clocks, IEEE 802.1AS, and SyncE per ITU-T G.8261/2.
- Cut-through mode for reduced traffic latency for Automotive 2.0 IVN.
- Support for cascading mode that enables the creation of a unified, single-CPU managed, 16- to 26-port switch.
- Support for high-end QoS capabilities with hierarchical scheduling, eight egress buffer queues per port (each with its own shaper), WRED and tail-drop congestion avoidance, and dual leaky-bucket ingress rate limiters.
- Advanced CFP (such as an access-list engine) that can classify up to L4 headers.
- Support for VSI for explicit segregation of bridging domains.
- Supports a standard Broadcom Switch SDK and a light-weight RoboSwitch SDK (RSDK).

Figure 2: BCM53162 Block Diagram

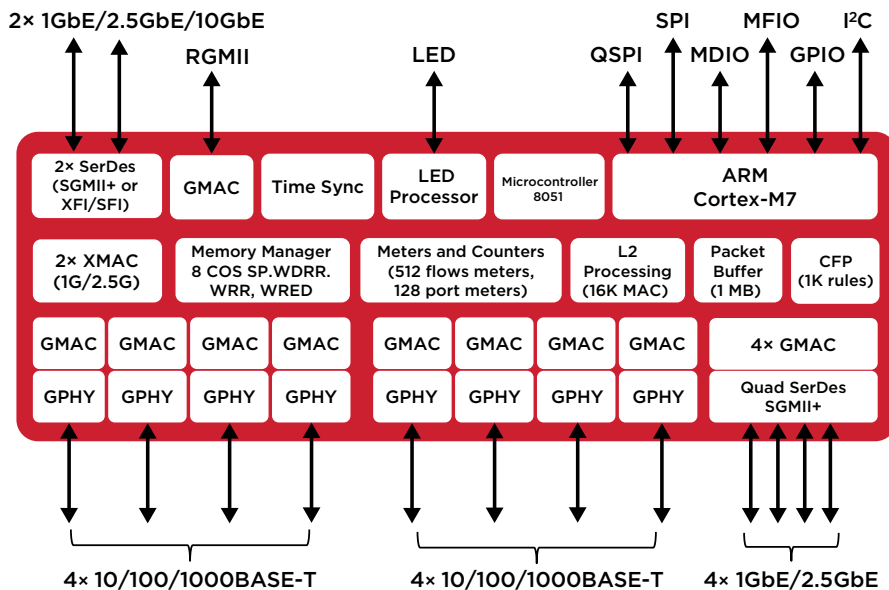

Ordering Information			
Description	Ambient Temperature	Package	Device ID
Intelligent, managed 2.5GbE Roboswitch-2 with 8× 10/100/1000BASE-T + 4× 1000FX/2500FX SGMII+ ports + 2× 1000FX/2500FX/10000FX XFI/SFI ports	Industrial (-40°C to +85°C)	19 mm x 19 mm	BCM53162XMB01LFBG

References:

- [1] The following Broadcom single/dual/quad/octal PHYs can be used: BCM54210SE, BCM54220SE, BCM54290, BCM54294, BCM54340, and BCM54380.
- [2] Automotive IVI certification process is underway.