

Octal high-side smart power solid-state relay with serial/parallel selectable interface on-chip

Datasheet - production data

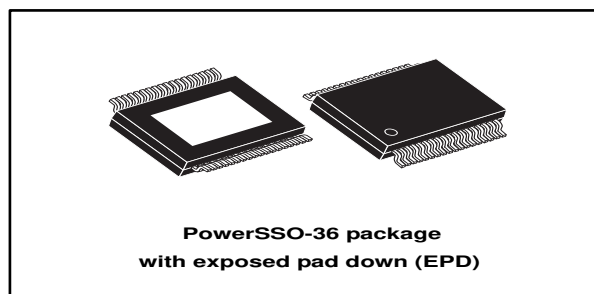

Features

Type	$V_{\text{demag}}^{(1)}$	$R_{\text{DS(on)}}^{(1)}$	$I_{\text{OUT}}^{(1)}$	V_{CC}
VNI8200XP	$V_{\text{CC}}-45\text{ V}$	$0.11\ \Omega$	0.7 A	45 V

Notes:

⁽¹⁾Per channel

- Output current: 0.7 A per channel
- Serial/parallel selectable interface
- Short-circuit protection
- 8-bit and 16-bit SPI Interface for IC command and control diagnostic
- Channel overtemperature detection and protection
- Thermal independence of separate channels
- Drives all type of loads (resistive, capacitive, inductive load)
- Loss of GND protection

- Power Good diagnostic
- Undervoltage shutdown with hysteresis
- Overvoltage protection (V_{CC} clamping)
- Very low supply current
- Common fault open drain output
- IC warning temperature detection
- Channel output enable
- 100 mA high efficiency step-down switching regulator with integrated boot diode
- Adjustable regulator output
- Switching regulator disable
- 5 V and 3.3 V compatible I/Os
- Channel output status LED driving 4x2 multiplexed array
- Fast demagnetization of inductive loads
- ESD protection
- Designed to meet IEC61131-2, IEC61000-4-4, and IEC61000-4-5

Applications

- Programmable logic control
- Industrial PC peripheral input/output
- Numerical control machines

Table 1: Device summary

Order code	Package	Packing
VNI8200XP	PowerSSO-36	Tube
VNI8200XPTR		Tape and reel

Contents

1	Description.....	6
2	Block diagram.....	7
3	Pin connection.....	8
4	Maximum ratings.....	10
5	Electrical characteristics	12
	5.1 Power section.....	12
	5.2 SPI characteristics	13
	5.3 Switching.....	13
	5.4 Logic inputs.....	14
	5.5 Protection and diagnostic.....	14
	5.6 Step-down switching regulator	16
	5.7 LED driving array	16
6	Reverse polarity protection	17
7	Demagnetization energy	18
8	Truth table.....	19
9	Pin function description.....	20
	9.1 SPI/parallel selection mode (SEL2).....	20
	9.2 Serial data in (SDI).....	20
	9.3 Serial data out (SDO).....	20
	9.4 Serial data clock (CLK)	20
	9.5 Slave select.....	21
	9.6 8/16-bit selection (SEL1).....	21
	9.7 Output enable (OUT_EN).....	21
	9.8 IC warning case temperature detection.....	22
	9.9 Fault indication	22
	9.10 Power Good ($\overline{\text{PG}}$)	23
	9.11 Programmable watchdog counter reset (WD)	23
10	SPI operation (SEL2 = H)	25
	10.1 8-bit SPI mode (SEL1 = L)	25
	10.2 16-bit SPI mode (SEL1 = H).....	25
11	LED driving array	27

12	Step-down switching regulator	28
13	Typical circuits and conventions	29
14	Thermal management	32
	14.1 Thermal behavior	33
15	Interface timing diagram	34
16	Switching parameter test conditions	35
17	Package information	36
	17.1 PowerSSO-36 package information	36
	17.2 PowerSSO-36 packing information	39
18	Revision history	42

List of tables

Table 1: Device summary	1
Table 2: Pin description	8
Table 3: Absolute maximum ratings	10
Table 4: Thermal data	11
Table 5: Power section	12
Table 6: SPI characteristics	13
Table 7: Switching	13
Table 8: Logic inputs	14
Table 9: Protection and diagnostic	14
Table 10: Step-down switching regulator	16
Table 11: LED driving array	16
Table 12: Truth table	19
Table 13: Pin function description	20
Table 14: Programmable watchdog time	23
Table 15: Command 8-bit frame (master-to-slave)	25
Table 16: Fault 8-bit frame (slave-to-master)	25
Table 17: Command 16-bit frame (master-to-slave)	25
Table 18: Fault 16-bit frame (slave-to-master)	26
Table 19: PowerSSO-36 mechanical data	38
Table 20: PowerSSO-36 tube shipment mechanical data	39
Table 21: PowerSSO-36 tape dimension mechanical data	40
Table 22: PowerSSO-36 reel dimension mechanical data	41
Table 23: Document revision history	42

List of figures

Figure 1: Block diagram	7
Figure 2: Pin connection (top view)	8
Figure 3: Reverse polarity protection	17
Figure 4: Maximum demagnetization energy vs. load current, typical values	18
Figure 5: SPI mode diagram	21
Figure 6: Output channel enable/disable behavior	22
Figure 7: Power Good diagnostic	23
Figure 8: Watchdog reset	24
Figure 9: LED driving array	27
Figure 10: Typical circuit for switching regulation $V_{DC-out} = 3.3\text{ V}$	29
Figure 11: Typical circuit for switching regulation $V_{DC-out} = 5\text{ V}$	30
Figure 12: SPI directional logic convention	31
Figure 13: PowerSSO-36 thermal impedance vs. time	32
Figure 14: Thermal behavior	33
Figure 15: Serial timing	34
Figure 16: $dV/dt(ON)$ and $dV/dt(OFF)$ time diagram test conditions	35
Figure 17: $t_{d(ON)}$ and $t_{d(OFF)}$ time diagram test conditions	35
Figure 18: PowerSSO-36 package outline	36
Figure 19: PowerSSO-36 package outline details	37
Figure 20: PowerSSO-36 package outline details (section B-B)	37
Figure 21: PowerSSO-36 tube shipment outline	39
Figure 22: PowerSSO-36 tape dimension outline	40
Figure 23: PowerSSO-36 reel shipment outline	41

1 Description

The VNI8200XP is a monolithic 8-channel driver featuring a very low supply current, with integrated SPI interface and high efficiency 100 mA micropower step-down switching regulator peak current control loop mode. The IC, realized in STMicroelectronics™ VIPower™ technology, is intended to drive any kind of load with one side connected to ground.

Active channel current limitation combined with thermal shutdown, independent for each channel, and automatic restart, protect the device against overload.

Additional embedded functions are: loss of GND protection that automatically turns off the device outputs in case of ground disconnection, undervoltage shutdown with hysteresis, Power Good diagnostic for valid supply voltage range recognition, output enable function for immediate power outputs ON/OFF, and programmable watchdog function for microcontroller safe operation; case overtemperature protection to control the IC case temperature.

The device embeds a four-wire SPI serial peripheral with selectable 8 or 16-bit operations; through a select pin the device can also operate with a parallel interface.

Both the 8-bit and 16-bit SPI operations are compatible with daisy chain connection.

The SPI interface allows command of the output driver by enabling or disabling each channel featuring, in 16-bit format, a parity check control for communication robustness. It also allows the monitoring of the status of the IC signaling Power Good, overtemperature condition for each channel, IC pre-warning temperature detection.

Built-in thermal shutdown protects the chip from overtemperature and short-circuit. In overload condition, the channel turns OFF and ON again automatically after the IC temperature decreases below a threshold fixed by a temperature hysteresis so that junction temperature is controlled. If this condition makes case temperature reaching case temperature limit, T_{CSD} , overloaded channels are turned OFF and restart, non-simultaneously, when case and junction temperature decrease below their own reset threshold. If the case of thermal reset, the channels loaded are not switched on until the junction temperature reset event. Non-overloaded channels continue to operate normally. Case temperature above T_{CSD} is reported through the \overline{TWARN} open drain pin.

An internal circuit provides a not latched common \overline{FAULT} indicator reporting if one of the following events occurs: channel OVT (overtemperature), parity check fail. The Power Good diagnostic warns the controller that the supply voltage is below a fixed threshold.

The watchdog function is used to detect the occurrence of a software fault of the host controller. The watchdog circuitry generates an internal reset on expiry of the internal watchdog timer. The watchdog timer reset can be achieved by applying a negative pulse on the WD pin. The watchdog function can be disabled by the WD_EN dedicated pin. This pin also allows the programming of a wide range of watchdog timings.

An internal LED matrix driver circuitry (4 rows, 2 columns) allows the detection of the status of the single outputs. An integrated step-down voltage regulator provides supply voltage to the internal LED matrix driver and logic output buffers and can be used to supply the external optocouplers if the application requires isolation. The regulator is protected against short-circuit or overload conditions thanks to pulse-by-pulse current limit with a peak current control loop.

2 Block diagram

Figure 1: Block diagram

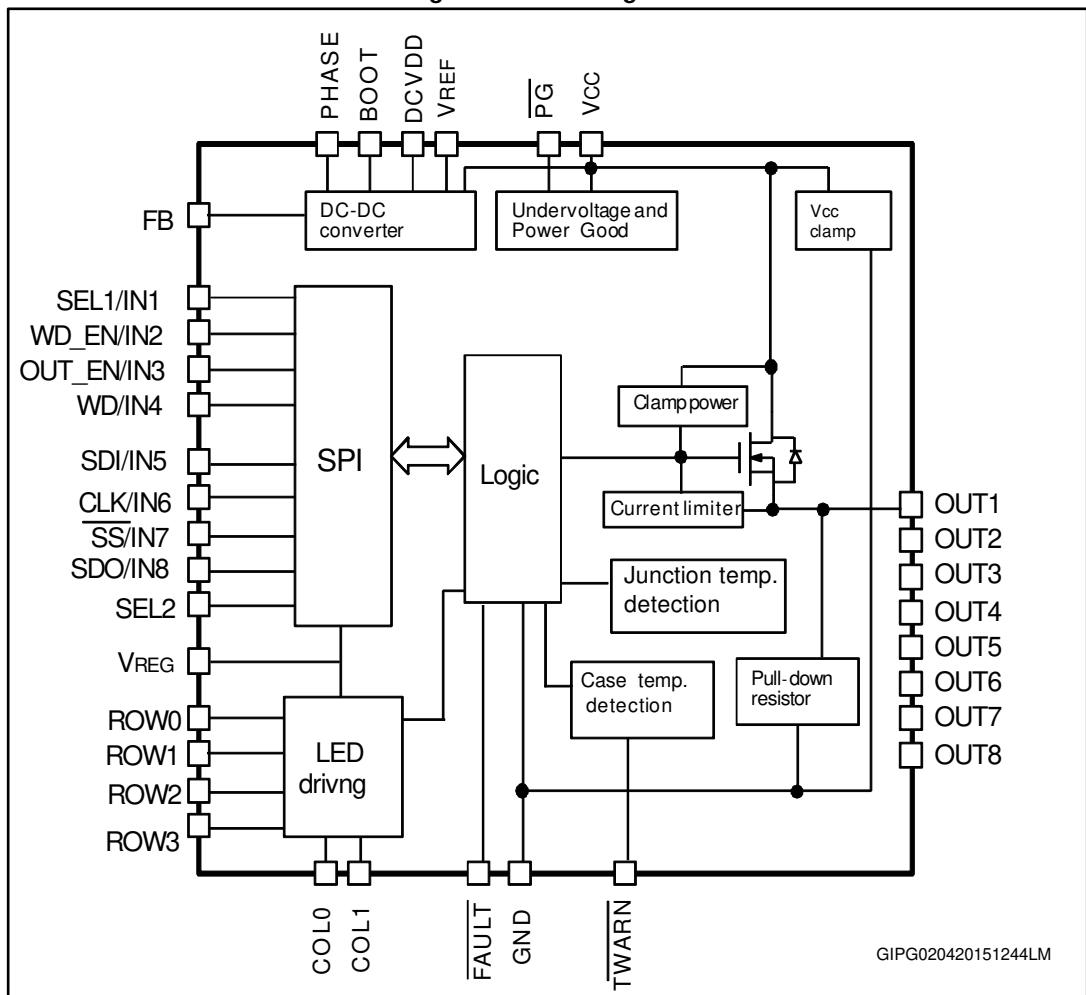

3 Pin connection

Figure 2: Pin connection (top view)

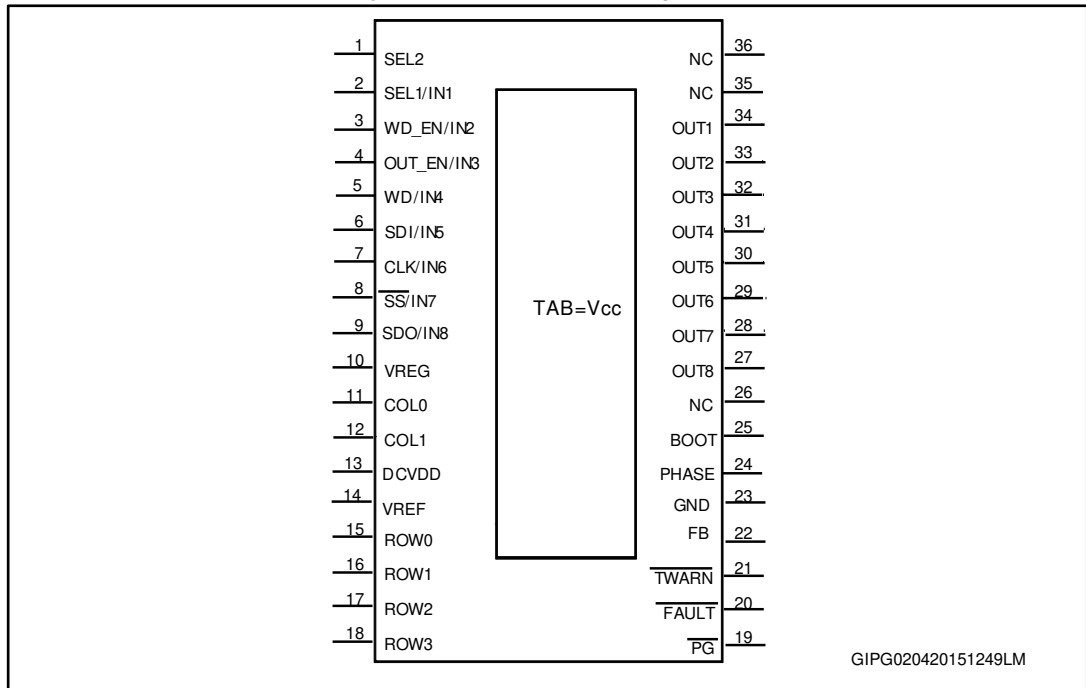

Table 2: Pin description

Pin	Name	Type	Description
1	SEL2	Logic input	SPI/parallel selection mode
2	SEL1/IN1	Logic input	8/16-bit SPI selection mode/channel 1 input
3	WD_EN/IN2	Logic/analog input	Watchdog enable_setting/channel 2 input
4	OUT_EN/IN3	Logic input	Output enable/channel 3 input
5	WD/IN4	Logic input	Watchdog input. The internal watchdog counter is cleared on the falling edges/channel 4 input
6	SDI/IN5	Logic input	Serial data input/channel 5 input
7	CLK/IN6	Logic input	Serial clock/channel 6 input
8	SS /IN7	Logic input	Slave select/channel 7 input
9	SDO/IN8	Logic input/output	Serial data output/channel 8 input
10	VREG	Power supply	SPI/inputs/LED supply voltage
11	COL0	Open source output	LED source output
12	COL1	Open source output	LED source output
13	DCVDD	Analog output	Internally generated DC-DC low voltage supply (to be connected to external 10 nF capacitor)
14	VREF	Analog output	Internally generated DC-DC voltage reference (to be connected to external 10 nF capacitor)
15	ROW0	Open drain output	Status channel 1-2

Pin	Name	Type	Description
16	ROW1	Open drain output	Status channel 3-4
17	ROW2	Open drain output	Status channel 5-6
18	ROW3	Open drain output	Status channel 7-8
19	$\overline{\text{PG}}$	Open drain output	Power Good diagnostic, active low
20	$\overline{\text{FAULT}}$	Open drain output	Fault indication, active low
21	$\overline{\text{TWARN}}$	Open drain output	IC case warning temperature detection, active low
22	FB	Analog input	Step-down feedback input. The output voltage, directly connected to this pin, results in an output voltage of 3.3 V. An external resistor divider is required for higher output voltages
23	GND		Ground
24	PHASE	Power output	Step-down output
25	BOOT	Power output	Step-down bootstrap voltage. Used to provide a drive voltage, higher than the supply voltage, to power the switch of the step-down regulator
26	NC		Not connected
27	OUT8	Power output	Channel 8 power output
28	OUT7	Power output	Channel 7 power output
29	OUT6	Power output	Channel 6 power output
30	OUT5	Power output	Channel 5 power output
31	OUT4	Power output	Channel 4 power output
32	OUT3	Power output	Channel 3 power output
33	OUT2	Power output	Channel 2 power output
34	OUT1	Power output	Channel 1 power output
35	NC		Not connected
36	NC		Not connected
TAB	TAB	Power supply	Exposed tab internally connected to V_{CC}

4 Maximum ratings

Table 3: Absolute maximum ratings

Symbol	Parameter	Value	Unit
V_{CC}	Power supply voltage	45	V
$-V_{CC}$	Reverse supply voltage	-0.3	V
V_{REG}	Logic supply voltage	-0.3 to +6	V
V_{FAULT} V_{TWARN} V_{PG}	Voltage range at pins \overline{TWARN} , \overline{FAULT} , \overline{PG}	-0.3 to +6	V
V_{BOOT}	Bootstrap peak voltage $V_{PHASE} = V_{CC}$	$V_{CC}+6$	V
V_{ROW}	Voltage range on ROW pins	-0.3 to +6	V
V_{COL}	Voltage range on COL pins	-0.3 to +6	V
V_{dig}	Voltage level range on logic input pins	-0.3 to +6	V
I_{OUT}	Output current (continuous)	Internally limited ⁽¹⁾	A
I_R	Reverse output current (per channel)	-5	A
I_{GND}	DC ground reverse current	-250	mA
I_{REG}	V_{REG} input current	-1/10	mA
I_{FAULT} I_{TWARN} , I_{PG}	Current range on pins \overline{TWARN} , \overline{FAULT} , \overline{PG}	-1 to +10	mA
I_{IN}	Input current range	-1 to +10	mA
I_{ROW}	Current range on ROW pins (ROW in ON-state)	+20	mA
	Current range on ROW pins (ROW in OFF-state)	-1 to +10	mA
I_{COL}	Current range on COL pins (COL in ON-state)	-10	mA
	Current range on COL pins (COL in OFF-state)	-1 to +10	mA
V_{ESD}	Electrostatic discharge (R = 1.5 k Ω ; C = 100 pF)	2000	V
E_{AS}	Single pulse avalanche energy per channel not simultaneously @ $T_{amb} = 125^\circ$, $I_{OUT} = 0.5$ A	3	J
P_{TOT}	Power dissipation at $T_C = 25^\circ\text{C}$	Internally limited ⁽¹⁾	W
T_J	Junction operating temperature	Internally limited	$^\circ\text{C}$
T_{STG}	Storage temperature	-55 to 150	$^\circ\text{C}$

Notes:

⁽¹⁾Protection functions are intended to avoid IC damage in fault conditions and are not intended for continuous operation. Continuous and repetitive operation of protection functions may reduce the IC lifetime.

Table 4: Thermal data

Symbol	Parameter		Value	Unit
$R_{th(JC)}$	Thermal resistance junction-case ⁽¹⁾	Max.	2	°C/W
$R_{th(JA)}$	Thermal resistance junction-ambient ⁽²⁾	Max.	15	°C/W

Notes:

⁽¹⁾Per channel.

⁽²⁾PowerSSO-36 mounted on the STEVAL-IFP022V1 developed on four-layer FR4, with about 8 cm² for each layer.

5 Electrical characteristics

5.1 Power section

10.5 V < V_{CC} < 36 V; -40 °C < T_J < 125 °C; unless otherwise specified

Table 5: Power section

Symbol	Parameter	Test conditions	Min.	Typ.	Max.	Unit
V _{CC}	Supply voltage		10.5		36	V
V _{CC} clamp	Clamp on V _{CC}	Current 20 mA	45	50	52	V
R _{DS(on)}	On-state resistance	I _{OUT} = 0.5 A at T _J = 25 °C		0.11		Ω
		I _{OUT} = 0.5 A			0.2	
I _S	V _{CC} supply current	All channels in OFF-state, DC-DC in OFF-state, V _{REG} =5 V, SPI OFF ⁽¹⁾	0.65		1.1	mA
		All channels in ON-state, DC-DC in OFF-state V _{REG} = 5 V, SPI ON ⁽²⁾	3.5		5.2	mA
		All channels in ON-state, DC-DC in ON-state V _{REG} = 5 V, SPI		5.3		
I _{DS}	V _{REG} supply current	DC-DC OFF V _{REG} = 5 V SPI OFF WD_EN = 0		200		μA
		DC/DC OFF V _{REG} = 5 V SPI ON WD_EN = V _{REG}		250		μA
I _{LGND}	Output current at GND disconnection	All pins at 0 V except V _{OUT} = 24 V			0.5	mA
V _{OUT(OFF)}	OFF-state output voltage	V _{IN} = 0 V, I _{OUT} = 0 A			1	V
I _{OUT(OFF)}	OFF-state output current	V _{IN} = V _{OUT} = 0 V	0		2	μA
F _{CP}	Charge pump frequency	Channel in ON-state ⁽³⁾		1.45		MHz

Notes:

⁽¹⁾ \overline{SS} signal high, no communication.

⁽²⁾ \overline{SS} signal low, communication ON.

⁽³⁾ To cover EN55022 class A and class B normative.

5.2 SPI characteristics

$10.5\text{ V} < V_{CC} < 36\text{ V}$; $2.7\text{ V} < V_{REG} < 5\text{ V}$; $-40 < T_j < 125\text{ }^\circ\text{C}$; unless otherwise specified

Table 6: SPI characteristics

Symbol	Parameter	Test conditions	Min.	Typ.	Max.	Unit
f_{CLK}	SPI clock frequency			-	5	MHz
$t_r(CLK)$, $t_f(CLK)$	SPI clock rise/fall time			-	20	ns
$t_{su}(\overline{SS})$	\overline{SS} setup time		120	-		ns
$t_h(\overline{SS})$	\overline{SS} hold time		120	-		ns
$t_w(CLK)$	CLK high time		80	-		ns
$t_{su}(SDI)$	Data input setup time		100	-		ns
$t_h(SDI)$	Data input hold time		100	-		ns
$t_a(SDO)$	Data output access time			-	100	ns
$t_{dis}(SDO)$	Data output disable time			-	200	ns
$t_v(SDO)$	Data output valid time			-	100	ns
$t_h(SDO)$	Data output hold time		0	-		ns
V_{SDO}	Voltage on serial data output	$I_{SDO} = 15\text{ mA}$	$V_{REG} - 0.8$	-		V
		$I_{SDO} = -4\text{ mA}$		-	0.8	V

5.3 Switching

$V_{CC} = 24\text{ V}$; $-40\text{ }^\circ\text{C} < T_j < 125\text{ }^\circ\text{C}$

Table 7: Switching

Symbol	Parameter	Test conditions	Min.	Typ.	Max.	Unit
$t_{d(ON)}$	Turn-ON delay time	$I_{OUT} = 0.5\text{ A}$, resistive load, input rise time $< 0.1\text{ }\mu\text{s}$	-	5	-	μs
t_r	Rise time	$I_{OUT} = 0.5\text{ A}$, resistive load, input rise time $< 0.1\text{ }\mu\text{s}$	-	5	-	μs
$t_{d(OFF)}$	Turn-OFF delay time	$I_{OUT} = 0.5\text{ A}$, resistive load, input rise time $< 0.1\text{ }\mu\text{s}$	-	10	-	μs
t_f	Fall time	$I_{OUT} = 0.5\text{ A}$, resistive load, input rise time $< 0.1\text{ }\mu\text{s}$	-	5	-	μs
$dV/dt_{(ON)}$	Turn-ON voltage slope	$I_{OUT} = 0.5\text{ A}$, resistive load, input rise time $< 0.1\text{ }\mu\text{s}$	-	3	-	$\text{V}/\mu\text{s}$
$dV/dt_{(OFF)}$	Turn-OFF voltage slope	$I_{OUT} = 0.5\text{ A}$, resistive load, input rise time $< 0.1\text{ }\mu\text{s}$	-	4	-	$\text{V}/\mu\text{s}$

5.4 Logic inputs

$10.5\text{ V} < V_{CC} < 36\text{ V}$; $-40\text{ }^{\circ}\text{C} < T_J < 125\text{ }^{\circ}\text{C}$; unless otherwise specified

Table 8: Logic inputs

Symbol	Parameter	Test conditions	Min.	Typ.	Max.	Unit
V_{IL}	Input low level voltage				0.8	V
V_{IH}	Input high level voltage		2.20			V
$V_{I(HYST)}$	Input hysteresis voltage			0.15		V
I_{IN}	Input current	$V_{IN} = 5\text{ V}$	8			μA

5.5 Protection and diagnostic

$10.5\text{ V} < V_{CC} < 36\text{ V}$; $-40\text{ }^{\circ}\text{C} < T_J < 125\text{ }^{\circ}\text{C}$; unless otherwise specified

Table 9: Protection and diagnostic

Symbol	Parameter	Test conditions	Min.	Typ.	Max.	Unit
V_{PGH1}	Power Good diagnostic ON threshold		16.5	17.5	18.4	V
V_{PGH2}	Power Good diagnostic OFF threshold		15.2	16.5	17.4	
V_{PGHYS}	Power Good diagnostic hysteresis			1		
V_{USD}	Undervoltage ON protection			9.5	10	V
	Undervoltage OFF protection		8.4	9		V
V_{USDHYS}	Undervoltage hysteresis		0.4	0.5		V
V_{demag}	Output voltage at turn-OFF	$I_{OUT} = 0.5\text{ A}$; $L_{LOAD} \geq 1\text{ mH}$	$V_{CC}-52$	$V_{CC}-50$	$V_{CC}-45$	V
V_{TWARN}	$\overline{\text{TWARN}}$ pin low-state output voltage	$I_{TWARN} = 3\text{ mA}$ (active condition)			0.6	V
V_{FAULT}	$\overline{\text{FAULT}}$ pin low-state output voltage	$I_{FAULT} = 3\text{ mA}$ (fault condition)			0.6	V
V_{PG}	$\overline{\text{PG}}$ pin low-state output voltage	$I_{PG} = 3\text{ mA}$ (active condition) $V_{REG} = 3.3\text{ V}$ $V_{CC} = 0$			0.7	V
I_{PEAK}	Maximum DC output current before limitation			1.4		A

Symbol	Parameter	Test conditions	Min.	Typ.	Max.	Unit
I_{LIM}	Short-circuit current limitation per channel	$R_{LOAD} = 0$ $V_{CC} = 24\text{ V}$ $T_J = 25\text{ °C}$	0.7	1.1	1.7	A
Hyst	I_{LIM} tracking limits	$R_{LOAD} = 0$		0.3		A
I_{LFAULT}	\overline{FAULT} leakage current	$V_{pin} = 5\text{ V}$			2	μA
I_{TWARN}	\overline{TWARN} leakage current					
I_{PG}	\overline{PG} leakage current					
T_{TSD}	Junction shutdown temperature		160	180		$^{\circ}\text{C}$
T_R	Junction reset temperature			160		$^{\circ}\text{C}$
T_{HIST}	Junction thermal hysteresis			20		$^{\circ}\text{C}$
T_{CSD}	Case shutdown temperature		115	130	155	$^{\circ}\text{C}$
T_{CR}	Case reset temperature			110		$^{\circ}\text{C}$
T_{CHYST}	Case thermal hysteresis			20		$^{\circ}\text{C}$
t_{WD}	Watchdog hold time		50			ns
t_{WM}	Watchdog time					
t_{OUT_EN}	OUT_EN pin propagation delay ⁽¹⁾	$V_{CC} = 24\text{ V}$ $I_{OUT} 72\text{ mA}$		10		μs
t_{res}	OUT_EN hold time		50			ns
t_{WO}	Watchdog timeout ⁽²⁾				$t_{WM} + t_{d(off)}$	ms

Notes:

⁽¹⁾Time from reset active low and power out disable.

⁽²⁾The time from t_{WM} elapsed to power out disable.

5.6 Step-down switching regulator

$10.5\text{ V} < V_{CC} < 36\text{ V}$; $-40\text{ }^{\circ}\text{C} < T_J < 125\text{ }^{\circ}\text{C}$; unless otherwise specified

Table 10: Step-down switching regulator

Symbol	Parameter	Test conditions	Min.	Typ.	Max.	Unit
V_{DC_out}	Regulated output voltage	I_{REG} from 0 to 100 mA V_{REG} 3.3 V	3.1	3.3	3.5	V
		I_{REG} from 0 to 100 mA V_{REG} 5 V		5		
V_{FB}	Voltage feedback		3.1	3.3	3.5	V
$R_{DS(on)}$	MOSFET on-resistance			1.5		Ω
I_{lim}	Limitation current		0.55		0.9	A
I_{qop}	Total operating quiescent current			0.6		mA
I_{qst-by}	Total standby quiescent current	Regulator standby		15.8		μA
f_s	Switching frequency			400		kHz
D_{max}	Maximum duty cycle			80%		%
T_{onmin}	Minimum on-time			150		ns
f_{sc}	Frequency in short-circuit condition			50		kHz

5.7 LED driving array

$10.5\text{ V} < V_{CC} < 36\text{ V}$; $-40\text{ }^{\circ}\text{C} < T_J < 125\text{ }^{\circ}\text{C}$; unless otherwise specified

Table 11: LED driving array

Symbol	Parameter	Test conditions	Min.	Typ.	Max.	Unit
V_{COL}	Output source voltage on COL pins	Output current 0 to 7 mA	$V_{REG}-0.3$	$V_{REG}-0.2$		V
V_{ROW}	Open drain voltage on ROW pins	Output current 0 to 15 mA		0.2	0.3	V
F_{sw}	Row refresh frequency with duty=25%			780		Hz

6 Reverse polarity protection

Reverse polarity protection can be implemented on board using two different solutions:

1. Placing a resistor (R_{GND}) between IC GND pin and load GND
2. Placing a diode between IC GND pin and load GND

If option 1 is selected, the minimum resistance value has to be selected according to the following equation:

$$R_{GND} \geq V_{CC} / I_{GND}$$

where I_{GND} is the DC reverse ground pin current and can be found in of this datasheet.

Power dissipated by R_{GND} (when $V_{CC} < 0$: during reverse polarity situations) is:

$$P_D = (V_{CC})^2 / R_{GND}$$

If option 2 is selected, the diode has to be chosen by taking into account $V_{RRM} > |V_{CC}|$ and its power dissipation capability:

$$P_D \geq I_S * V_F$$



In normal conditions (no reverse polarity), due to the diode, there is a voltage drop between GND of the device and GND of the system.

Figure 3: Reverse polarity protection

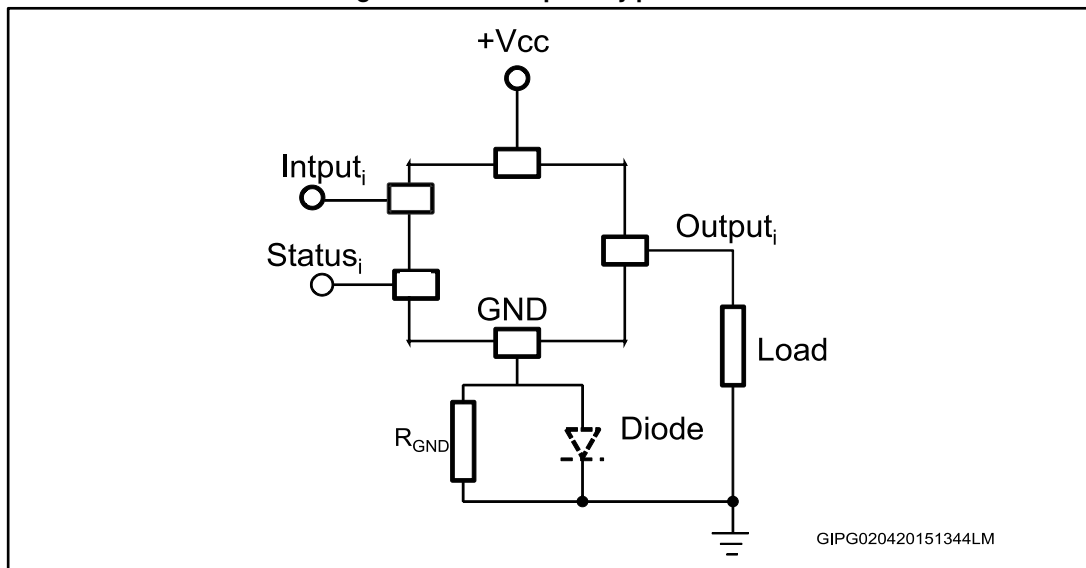

This schematic can be used with any type of load.

7 Demagnetization energy

Figure 4: Maximum demagnetization energy vs. load current, typical values

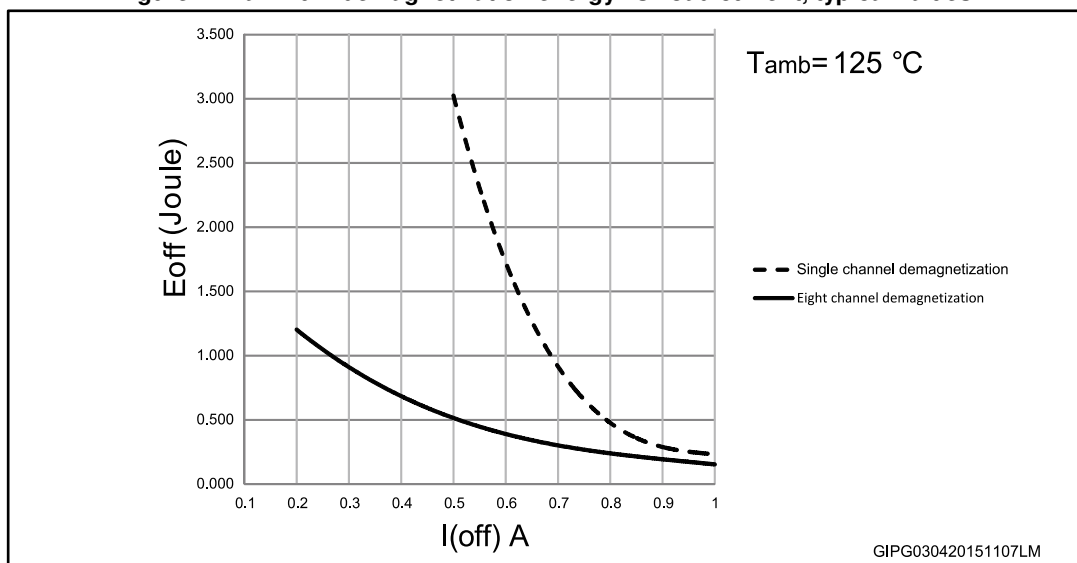

8 Truth table

Table 12: Truth table

Condition	Input	Output	SPI status bit	$\overline{\text{FAULT}}$	$\overline{\text{TWARN}}$	Power Good
Normal operation	High	On	Reset	High	High	High
	Low	Off	Reset	High	High	High
Junction overtemperature	High	Off	Set	Low	X	X
	Low	Off	Set ⁽¹⁾	High	X	X
Case overtemperature	High	Off	Set ⁽¹⁾	X	Low	X
	Low	Off	Set ⁽¹⁾	X	Low ⁽¹⁾	X
Undervoltage	High	Off	Reset	X	X	X
	Low	Off	Reset	X	X	X
Power Good	High	On	Set ⁽²⁾	High	High	Low
	Low	Off	Set ⁽²⁾	High	High	Low

Notes:

⁽¹⁾This signal becomes high after the temperature falls below the reset threshold.

⁽²⁾If fault expires, the reset condition occurs after SPI communication, otherwise it is set again.

9 Pin function description

9.1 SPI/parallel selection mode (SEL2)

This pin allows the selection of the IC interfacing mode. The SPI interface is selected if SEL2 = H, while the parallel interface is selected if SEL2 = L, according to:

Table 13: Pin function description

Pin	SEL2 = H ^a SPI operation		SEL2 = L parallel operation	
	SDO/IN8	SDO	Serial data output	IN8
\overline{SS} /IN7	\overline{SS}	Slave select	IN7	Input to channel 7
CLK/IN6	CLK	Serial clock	IN6	Input to channel 6
SDI/IN5	SDI	Serial data input	IN5	Input to channel 5
WD/IN4	WD	Watchdog input	IN4	Input to channel 4
OUT_EN / IN3	OUT_EN	IC OUTPUT enable / disable	IN3	Input to channel 3
WD_EN/IN2	WD_EN	Watchdog enable / disable and timing preset	IN2	Input to channel 2
SEL1/IN1	SEL1	8/16-bit SPI selection mode	IN1	Input to channel 1

9.2 Serial data in (SDI)

If SEL2 = H, this pin is the input of the serial control frame. SDI is read on CLK rising edges and, therefore, the microcontroller must change SDI state during the CLK falling edges.

After the \overline{SS} falling edge, the SDI is equal to the most significant bit of the control frame.

9.3 Serial data out (SDO)

If SEL2 = H, this pin is the output of the serial fault frame. SDO is updated on CLK falling edges and, therefore, the microcontroller must read SDO state during the CLK rising edges.

The SDO pin is tri-stated when \overline{SS} signal is high and it is equal to the most significant bit of the fault frame after the \overline{SS} falling edge.

9.4 Serial data clock (CLK)

If SEL2 = H, the CLK line is the input clock for serial data sampling. On CLK rising edge the SDI input is sampled by the IC and the SDO output is sampled by the host microcontroller. On CLK falling edge, both SDI and SDO lines are updated to the next bit of the frame, from the most to the less significant one. When the \overline{SS} signal is high, slave not selected, the microcontroller should drive the CLK low (the settings for the MCU SPI port are CPHA = 0 and CPOL = 0).

^a SEL2 has an internal weak pull-down.

9.5 Slave select

If SEL2 = H, the slave select (\overline{SS}) signal is used to enable the VNI8200XP serial communication shift register; data is flushed-in through the SDI pin and flushed-out from the SDO pin only when the \overline{SS} pin is low. On the \overline{SS} pin falling edge the shift register (containing the fault conditions) is frozen, so any change on the power switches status is latched until the next \overline{SS} falling edge event and the SDO output is enabled. On the \overline{SS} pin rising edge event the 8/16 bits present on the SPI shift register are evaluated and the outputs are driven according to this frame. If more than 8/16 bits (depending on the SPI settings) are flushed inside only the last 8/16 are evaluated; the others are flushed out from the SDO pin after fault condition bits; in this way a proper communication is possible also in a daisy chain configuration.

Figure 5: SPI mode diagram

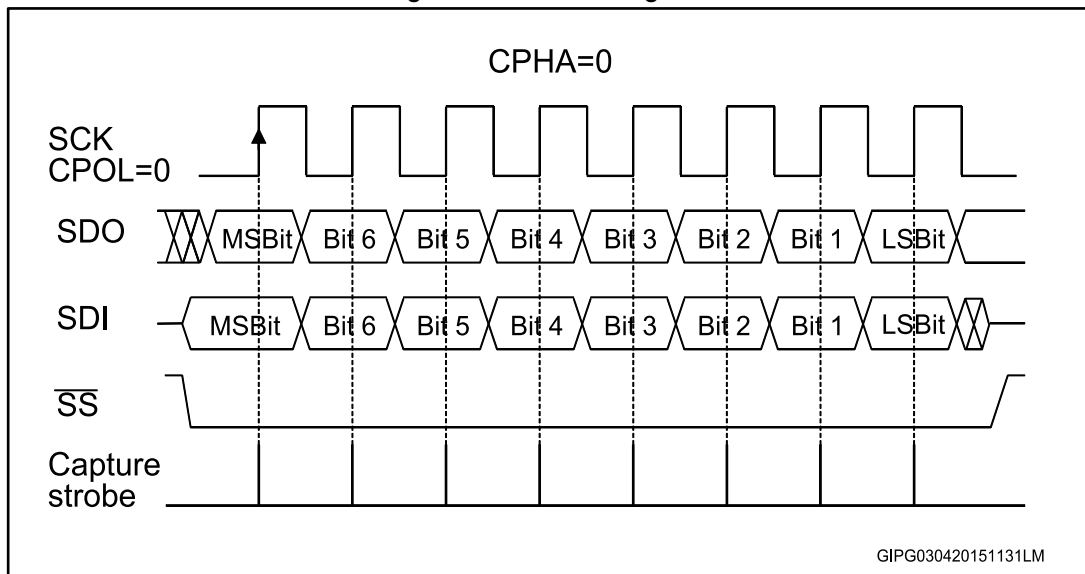

9.6 8/16-bit selection (SEL1)

If SEL2 = H, SEL1 is used to select between two possible SPI configurations: the 8-bit SPI mode (SEL1 = L) and the 16-bit SPI mode (SEL1 = H). 8/16-bit SPI operation is described below.

9.7 Output enable (OUT_EN)

If SEL2 = H, the OUT_EN pin provides a fast way to disable all the outputs simultaneously. When the OUT_EN pin is driven low for at least T_{RES} , the outputs are disabled while fault conditions in the SPI register are latched. To enable the outputs, the OUT_EN pin should be raised and the IC should be re-programmed through the SPI interface. As fault conditions are latched inside the IC and SPI interface also works while the OUT_EN pin is driven low, the SPI can be used to detect if a fault condition occurred before than the reset event.

The device is ready to operate normally after a T_{SU} period. The OUT_EN pin is the fastest way to disable all outputs when a fault occurs.

Figure 6: Output channel enable/disable behavior

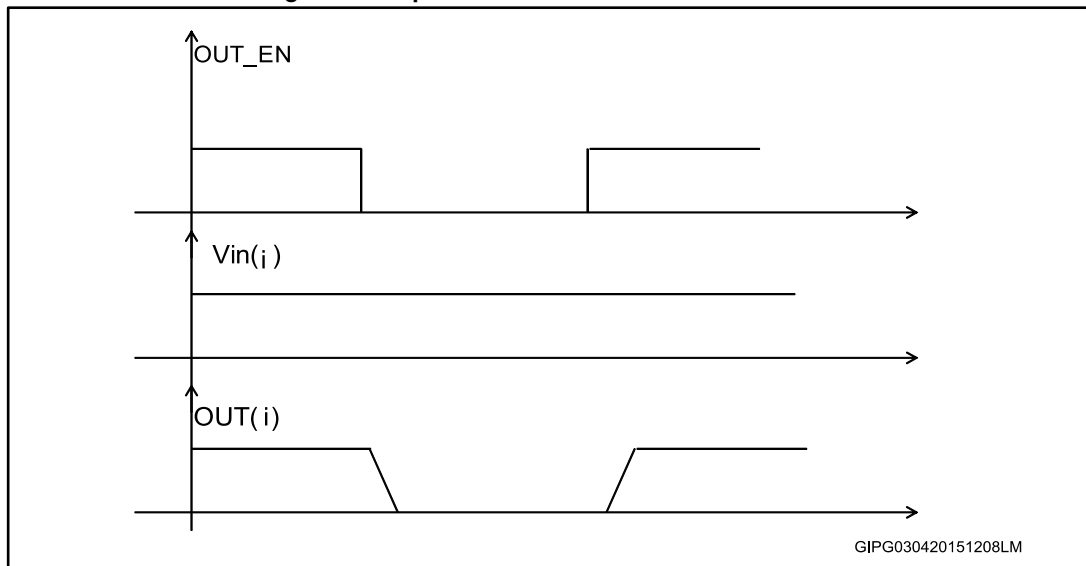

9.8 IC warning case temperature detection

The $\overline{\text{TWARN}}$ pin is an active low open drain output. This pin is activated if the IC case temperature exceeds T_{CSD} . According to the PCB thermal design and R_{thJC} value, this function allows a warning about a PCB overheating condition to be given.

The $\overline{\text{TWARN}}$ bit is also available through SPI. This bit is not latched: the $\overline{\text{TWARN}}$ pin is low only while the case overtemperature condition is active ($T_{\text{C}} > T_{\text{CSD}}$) and is released when this condition is removed ($T_{\text{C}} < T_{\text{CR}}$).

9.9 Fault indication

The $\overline{\text{FAULT}}$ pin is an open drain active low fault indication pin. This pin is activated by one or more of the following conditions:

- Channel overtemperature (OVT)

This pin is activated when at least one of the channels is in junction overtemperature.

Unlike the SPI fault detection bits, this signal is not latched: the $\overline{\text{FAULT}}$ pin is low only when the fault condition is active and is released if the input driving signal is OFF or after the OVT protection condition has been removed. This last event occurs if the channel temperature decreases below the threshold level and the case temperature has not exceeded T_{CSD} or is below T_{CR} . This means that the $\overline{\text{FAULT}}$ pin is low only while the junction overtemperature is active ($T_{\text{J}} > T_{\text{TTSD}}$) and is released after this condition has been removed ($T_{\text{J}} < T_{\text{TR}}$ and $T_{\text{C}} < T_{\text{CR}}$).

- Parity check fail

When SPI mode is used ($\text{SEL2} = \text{H}$), if a parity check fault of the incoming SPI frame is detected or counted, CLK rising edges are different by a multiple of 8, the $\overline{\text{FAULT}}$ pin is kept low. When counted CLK rising edges are a multiple of 8 and parity check is valid, the $\overline{\text{FAULT}}$ pin is kept high.

9.10 Power Good ($\overline{\text{PG}}$)

The $\overline{\text{PG}}$ terminal is an open drain, which indicates the status of the supply voltage. When V_{CC} supply voltage reaches the V_{sth1} threshold, $\overline{\text{PG}}$ goes into a high impedance state. It goes into a low impedance state when V_{CC} falls below the V_{sth2} threshold.

In 16-bit SPI mode, a $\overline{\text{PG}}$ bit is also available. This bit is set high when the Power Good diagnostic is active, it is otherwise cleared.

Figure 7: Power Good diagnostic

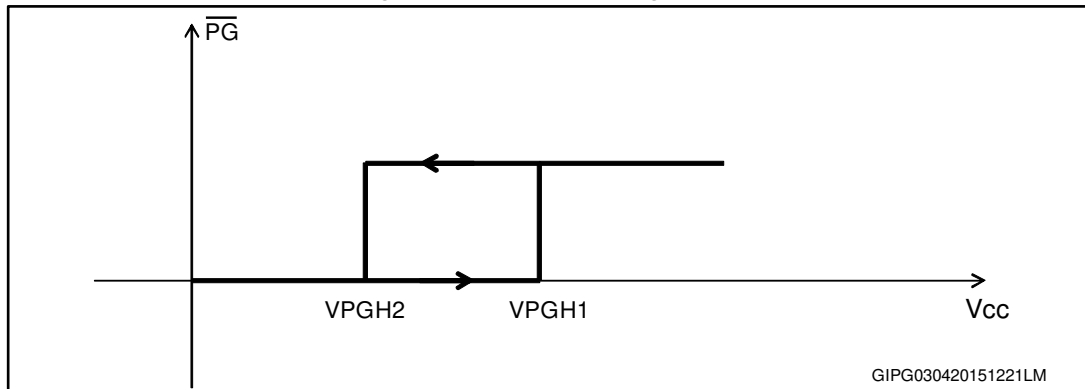

9.11 Programmable watchdog counter reset (WD)

If $\text{SEL2} = \text{H}$, the VNI8200XP embeds a watchdog counter that must be erased, with a negative pulse on the WD pin, before it expires. If the WD counter elapses, the VNI8200XP goes into an internal reset state where all the outputs are disabled; to restart normal operation a negative pulse must be applied to the WD pin.

The watchdog enable/disable pin should be connected through an external divider to V_{REG} . The watchdog time is fixed in the following table:

Table 14: Programmable watchdog time

$V_{\text{WD_EN}}$	t_{WM}
$0.25 V_{\text{REG}} > V_{\text{WD_EN}}$	Disable
$0.25 V_{\text{REG}} \leq V_{\text{WD_EN}} < 0.5 V_{\text{REG}}$	$40 \pm 25\% \text{ ms}$
$0.25 V_{\text{REG}} \leq V_{\text{WD_EN}} < 0.75 V_{\text{REG}}$	$80 \pm 25\% \text{ ms}$
$0.75 V_{\text{REG}} \leq V_{\text{WD_EN}} = V_{\text{REG}}$	$160 \pm 25\% \text{ ms}$

Figure 8: Watchdog reset

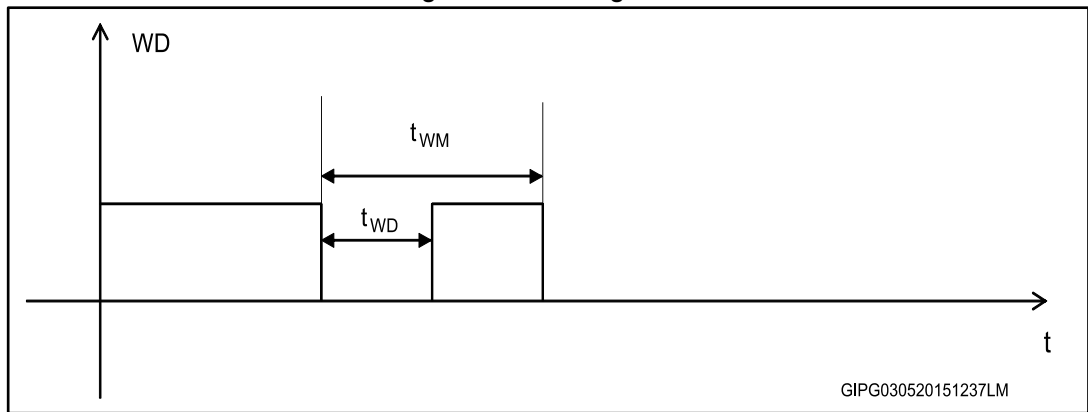

10 SPI operation (SEL2 = H)

10.1 8-bit SPI mode (SEL1 = L)

If SEL2 = H, the 8-bit SPI mode is based on an 8-bit command frame sent from the microcontroller to the IC; each bit directly drives the corresponding output where LSB drives output 0 and MSB drives output 7. Each bit, set to '1', activates (closes) the corresponding output.

At the same time, the IC transfers the channel fault conditions (OVT) to the microcontroller. These fault conditions are latched at the occurrence and cleared after each communication (each time the \overline{SS} signal has a positive transition). Each bit, set to '1', indicates an OVT condition for the corresponding channel.

Table 15: Command 8-bit frame (master-to-slave)

MSB								LSB
IN7	IN6	IN5	IN4	IN3	IN2	IN1	IN0	

Table 16: Fault 8-bit frame (slave-to-master)

MSB								LSB
F7	F6	F5	F4	F3	F2	F1	F0	

10.2 16-bit SPI mode (SEL1 = H)

The 16-bit SPI mode is based on a 16-bit command frame sent from the microcontroller to the IC; the first 8 bits directly drive the output channels (each bit, set to '1', activates the corresponding output), the other 8 bits contain a 4-bit parity check code where the last bit (the inversion of the previous one) is used to detect a communication error condition (providing at least a transition in each frame):

$$P0 = IN0 + IN1 + IN2 + IN3 + IN4 + IN5 + IN6 + IN7$$

$$P1 = IN1 + IN3 + IN5 + IN7$$

$$P2 = IN0 + IN2 + IN4 + IN6$$

$$nP0 = \text{Not } P0$$

Table 17: Command 16-bit frame (master-to-slave)

MSB													LSB		
IN7	IN6	IN5	IN4	IN3	IN2	IN1	IN0					P2	P1	P0	nP0

At the same time, the IC transfers to the microcontroller a 16-bit fault frame where the first 8 bits indicate a channel fault (OVT) condition (each bit, set to '1', indicates an OVT event), the following 4 bits provide general fault condition information. FB_OK: this bit is related to the DC-DC regulation: at the DC-DC turn-on, this bit is low and becomes high after FB rises above 90% of the nominal V_{FB} voltage and a correct SPI communication occurred. If the FB voltage falls below 80% of the nominal V_{FB} voltage, this bit is zero; \overline{TWARN} (IC warning case temperature), PC (parity check fail, the bit, set to '1', indicates a PC fail or the

length is not a multiple of 8) and \overline{PG} (Power Good). The last 4 bits are used as parity check bits and communication error condition (see command 16-bit frame):

$$P0 = F0 + F1 + F2 + F3 + F4 + F5 + F6 + F7$$

$$P1 = PC + \overline{FB_OK} + F1 + F3 + F5 + F7$$

$$P2 = \overline{PG} + \overline{TWARN} + F0 + F2 + F4 + F6$$

$$nP0 = \text{not } P0$$

Table 18: Fault 16-bit frame (slave-to-master)

MSB															LSB
F7	F6	F5	F4	F3	F2	F1	F0	FB_OK	\overline{TWARN}	PC	\overline{PG}	P2	P1	P0	nP0

Channel indications are latched and cleared after a communication only.

11 LED driving array

The LED driving array carries out the status of the output channels (ON or OFF).

Figure 9: LED driving array

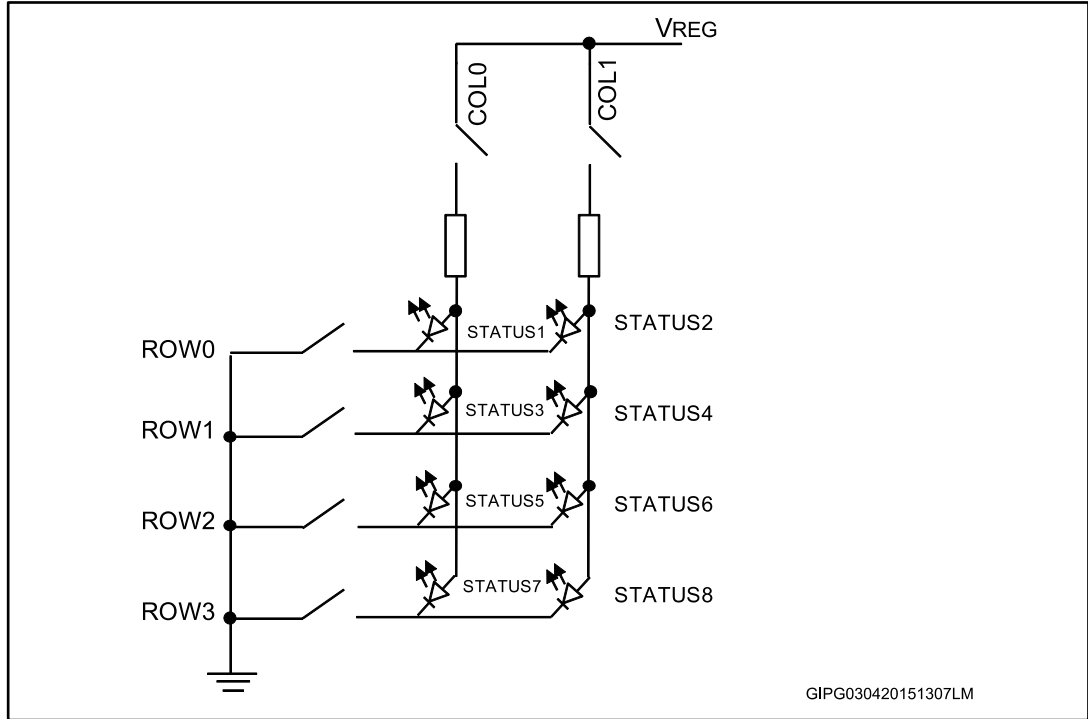

The following equation is an indication how to choose the R_{ext} resistor value:

$$R_{ext} = (V_{COLmin.}) - (V_{ROWmax.}) - V_{F(LED)} / I_{F(LED)}$$

where $I_{F(LED)} \leq 7 \text{ mA}$ and $(V_{COL min.})$ and $(V_{ROW max.})$ can be found in and $V_{F(LED)}$ and $I_{F(LED)}$ depend on the electrical characteristics of the LEDs.

12 Step-down switching regulator

The IC embeds a high efficiency 100 mA micropower step-down switching regulator. The regulator is protected against short-circuit or overload conditions. Pulse-by-pulse current limit regulation is obtained in normal operation through a current loop control.

A low ESR output capacitor connected to the V_{REG} pin helps to limit the regulated voltage ripple; a low ESR (less than 10 m Ω) capacitor is preferable. The control loop pin FB allows 3.3 V to be regulated, connecting it directly to V_{REG} , or 5 V connecting it through a voltage divider R_1/R_{fb} . The DC-DC converter can be turned off by connecting the feedback pin to the DCVDD pin. In some applications it is possible to supply a 5 V or 3.3 V voltage externally or, in the case of two or more VNI8200XP inside the same board, it's possible to configure the DC-DC converter on only one device and also supply the other ICs.

if the DC-DC converter is adjusted to provide 3.3 V regulation and the V_{DC_out} is used to power an external load and not the device, a 33 k Ω resistor has to be connected on V_{DC_out} pin.

13 Typical circuits and conventions

Figure 10: Typical circuit for switching regulation $V_{DC-out} = 3.3 V$

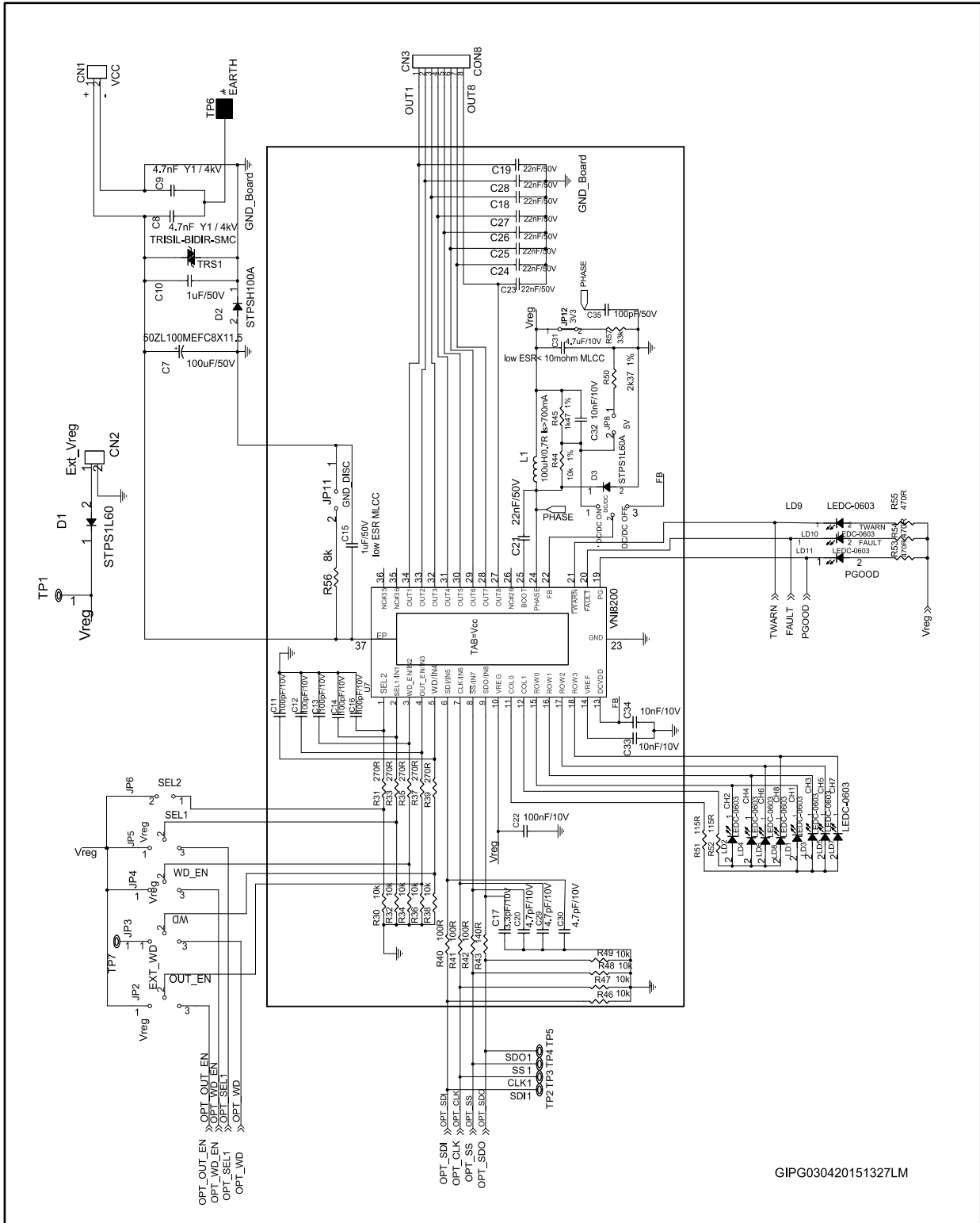

GIPG030420151327LM

Figure 11: Typical circuit for switching regulation $V_{DC-out} = 5 V$

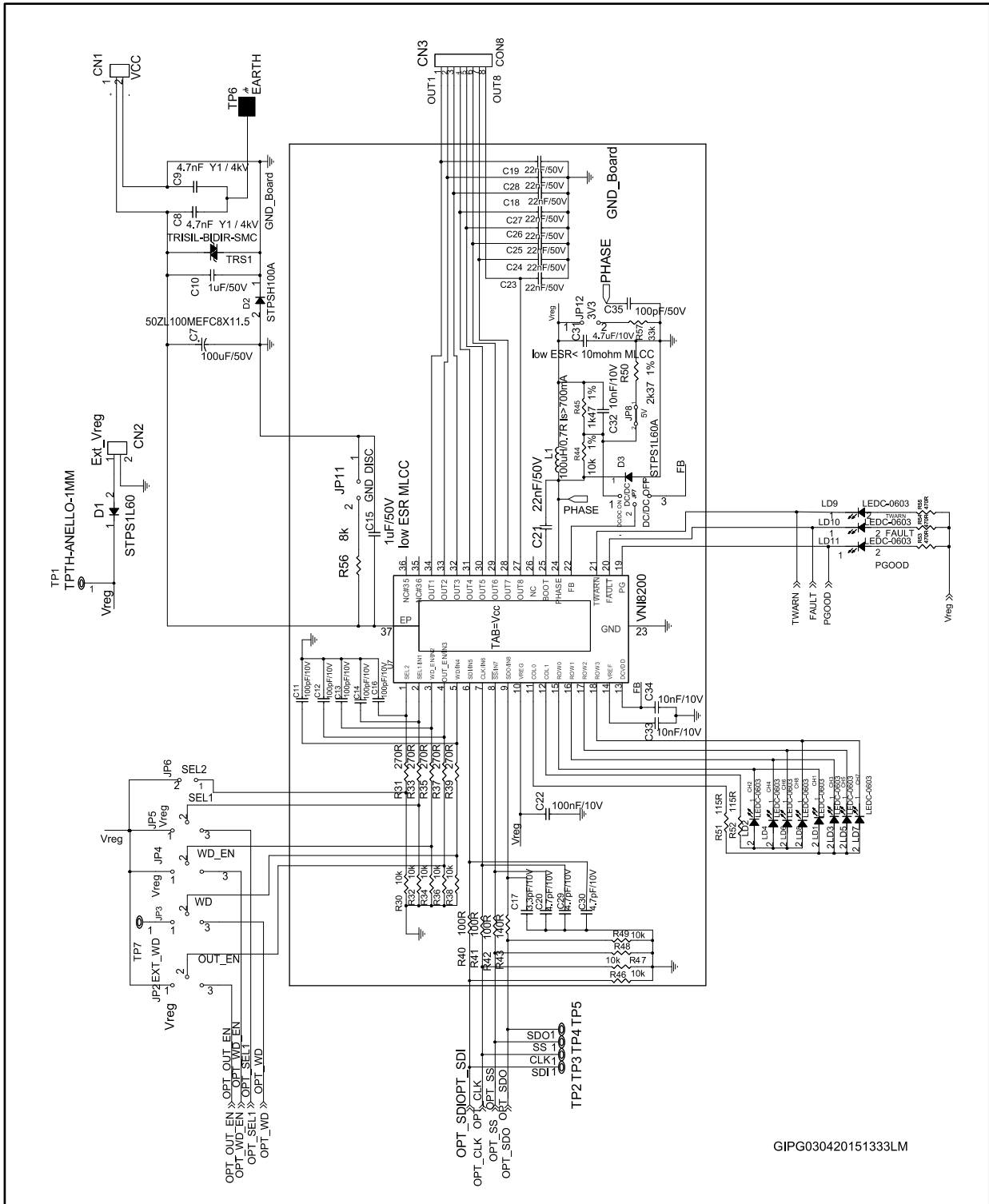

GIPG030420151333LM

Figure 12: SPI directional logic convention

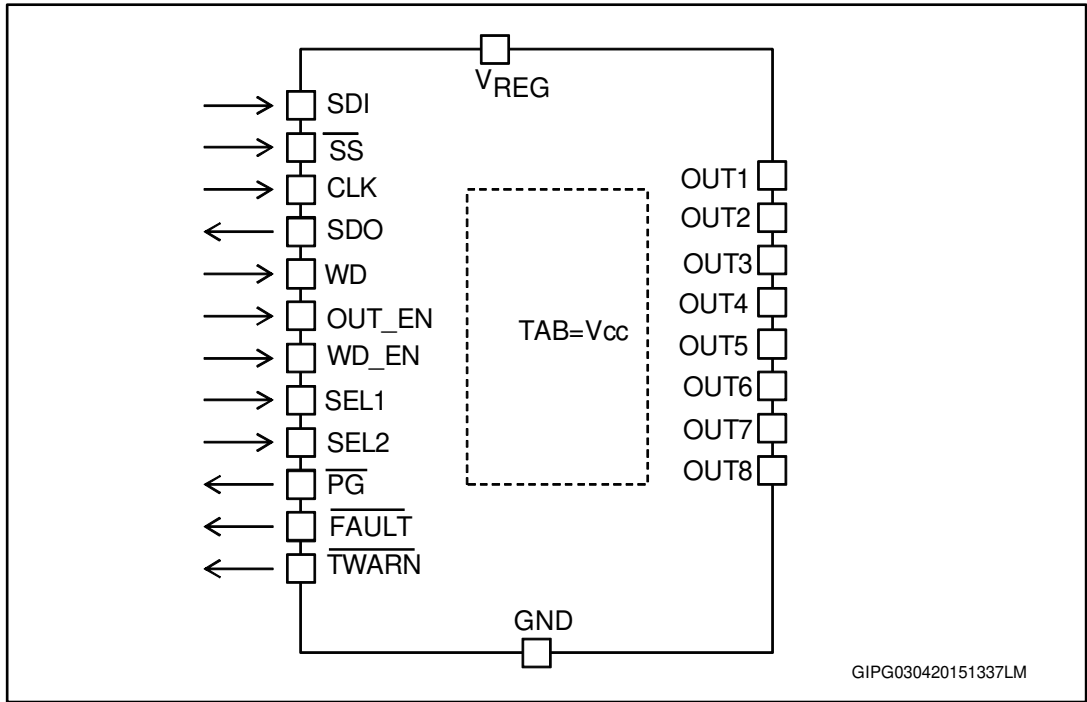

14 Thermal management

The power dissipation in the IC is the main factor that sets the safe operating condition of the device in the application. Therefore, it must be taken into account very carefully. Heatsinking can be achieved using copper on the PCB with proper area and thickness. The following image shows the junction-to-ambient thermal impedance values for the PowerSSO-36 package.

Figure 13: PowerSSO-36 thermal impedance vs. time

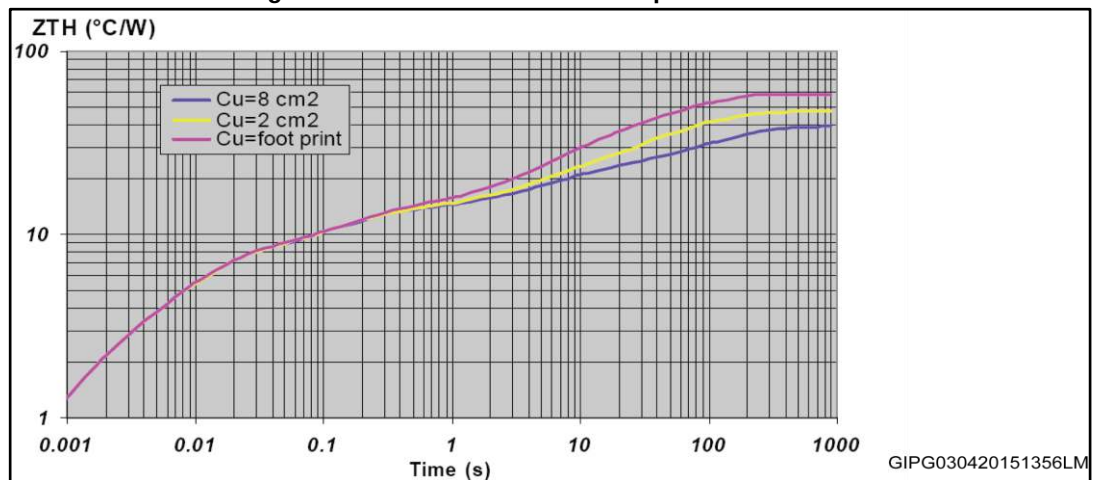

For instance, three cases have been considered using a PowerSSO-36 packaged with copper slug soldered on a 1.6 mm thickness FR4 board with dissipating footprint (copper thickness of 70 μm):

- single layer PCB with just IC footprint dissipating area
- double layer PCB with footprint dissipating area on the top side and a 2 cm² dissipating layer on the bottom side through 15 via holes
- double layer PCB with footprint dissipating area on the top side and an 8 cm² dissipating layer on the bottom side through 15 via holes

14.1 Thermal behavior

Figure 14: Thermal behavior

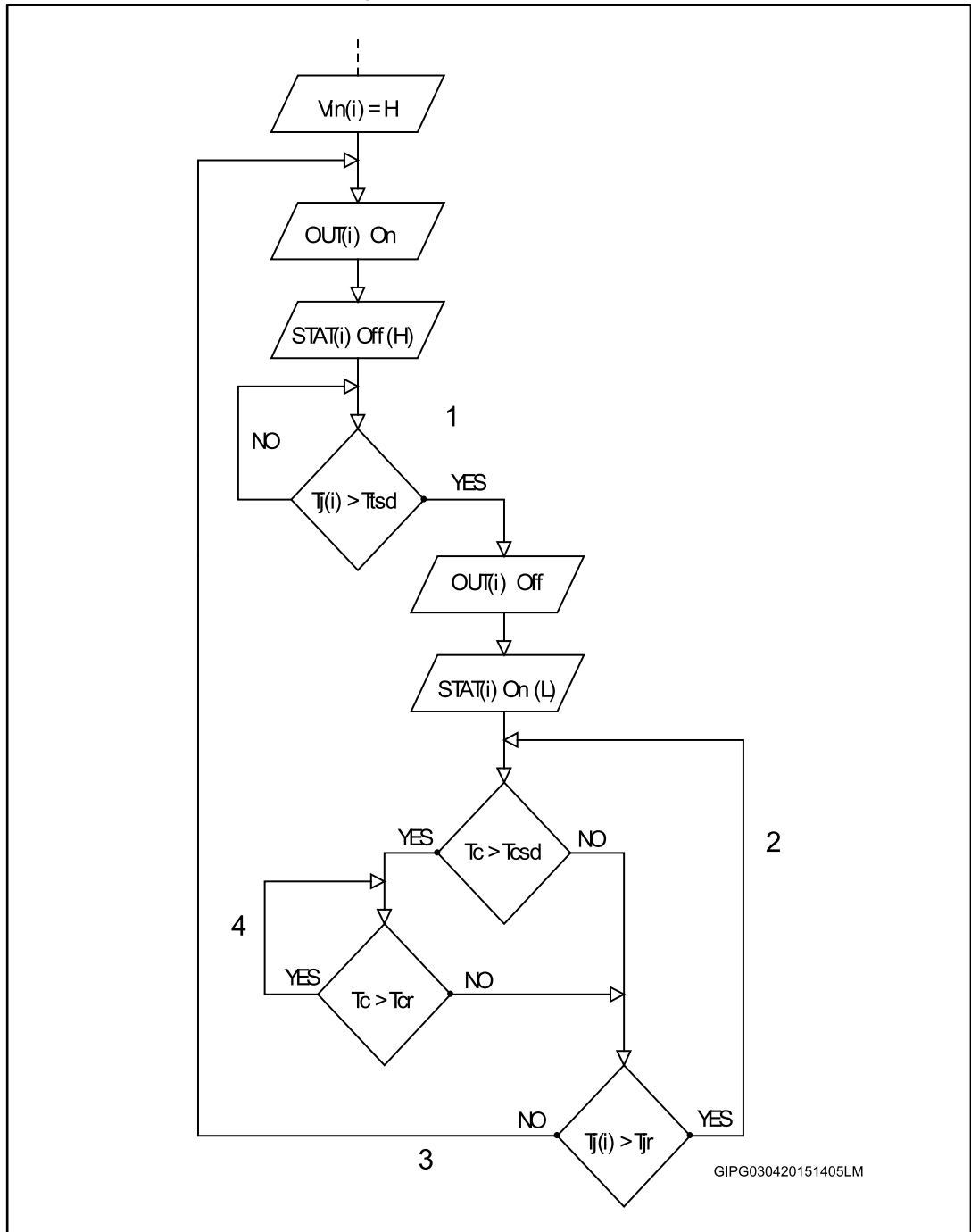

GIPG030420151405LM



- 1 Thermal shutdown
- 2 Junction hysteresis
- 3 Restore to idle condition
- 4 Case hysteresis

15 Interface timing diagram

Figure 15: Serial timing

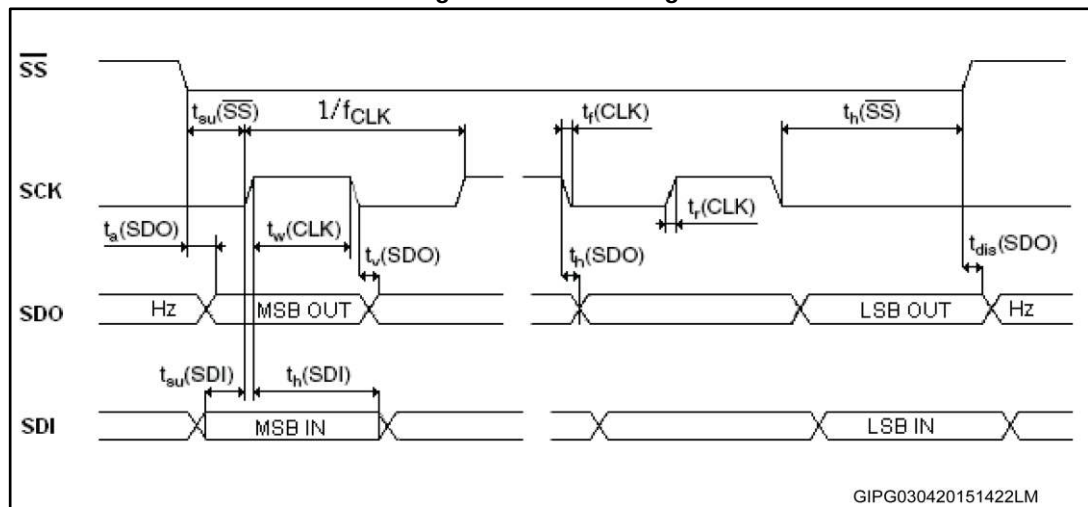

16 Switching parameter test conditions

Figure 16: $dV/dt(ON)$ and $dV/dt(OFF)$ time diagram test conditions

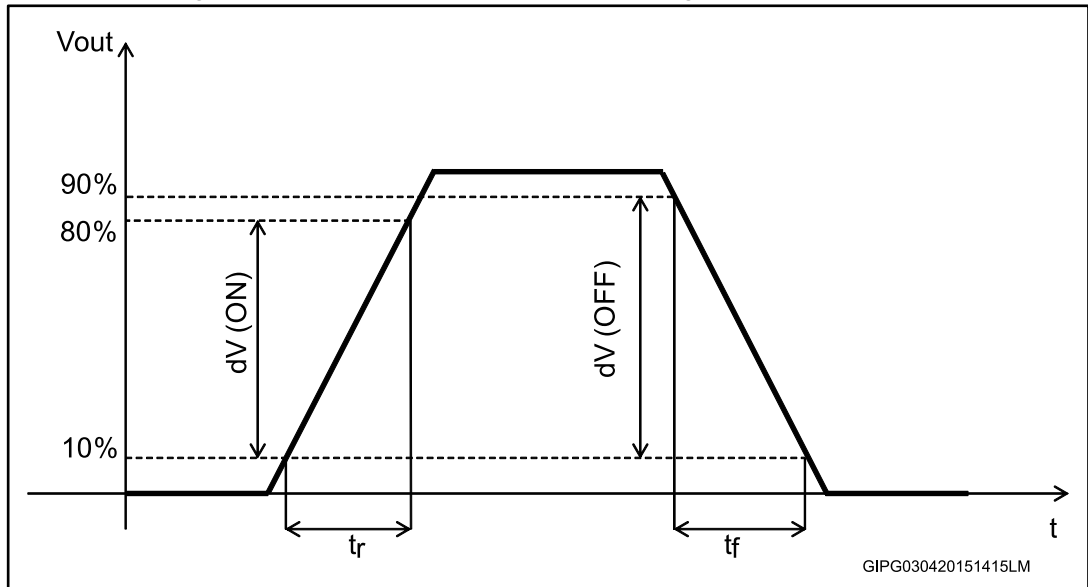
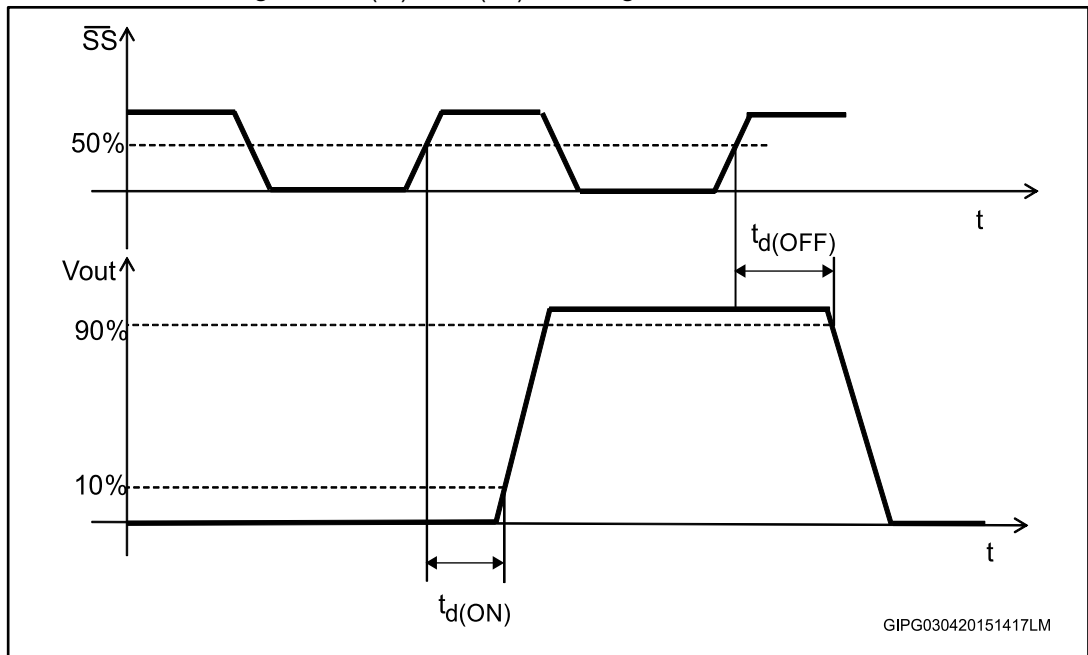

Figure 17: $t_{d(ON)}$ and $t_{d(OFF)}$ time diagram test conditions



17 Package information

In order to meet environmental requirements, ST offers these devices in different grades of ECOPACK® packages, depending on their level of environmental compliance. ECOPACK® specifications, grade definitions and product status are available at: www.st.com. ECOPACK® is an ST trademark.

17.1 PowerSSO-36 package information

Figure 18: PowerSSO-36 package outline

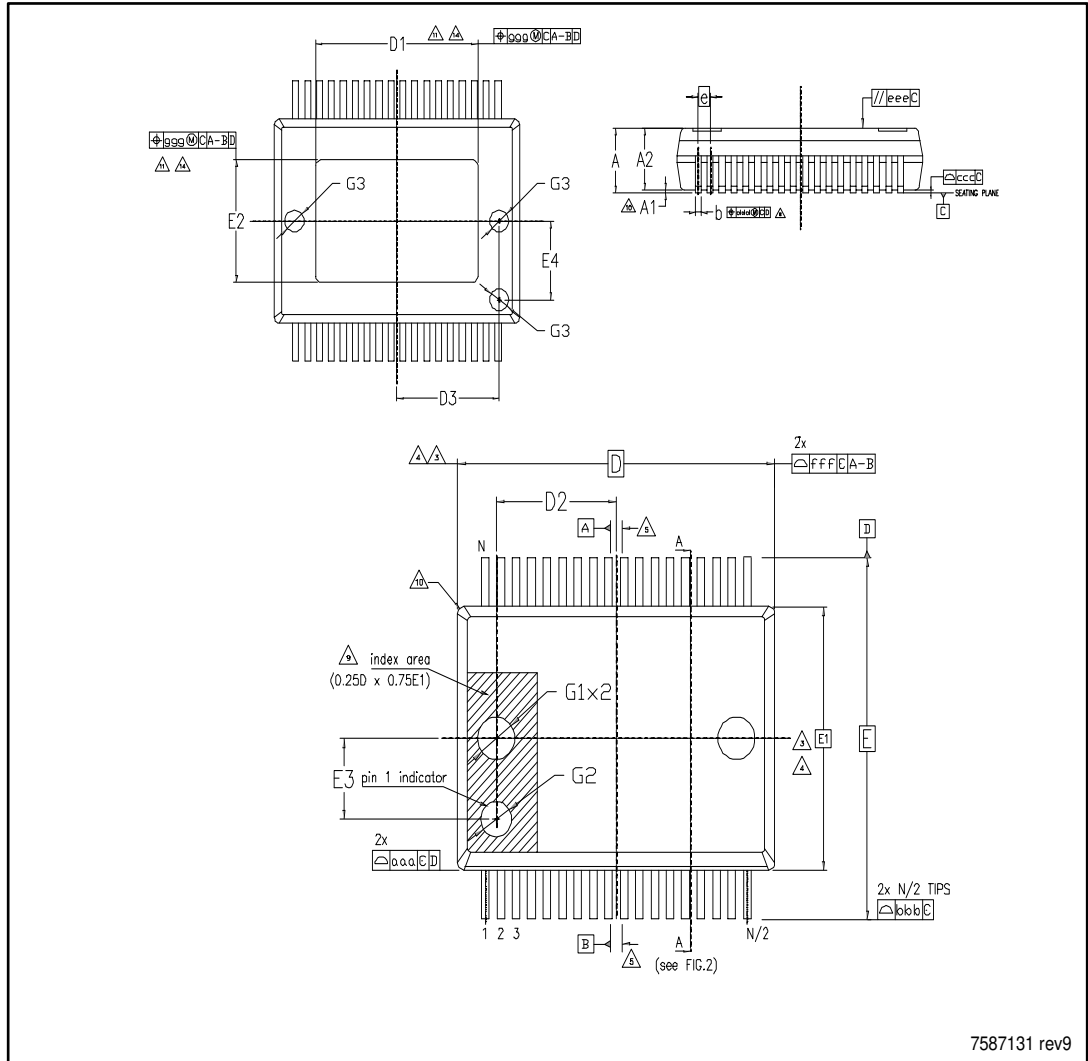

Figure 19: PowerSSO-36 package outline details

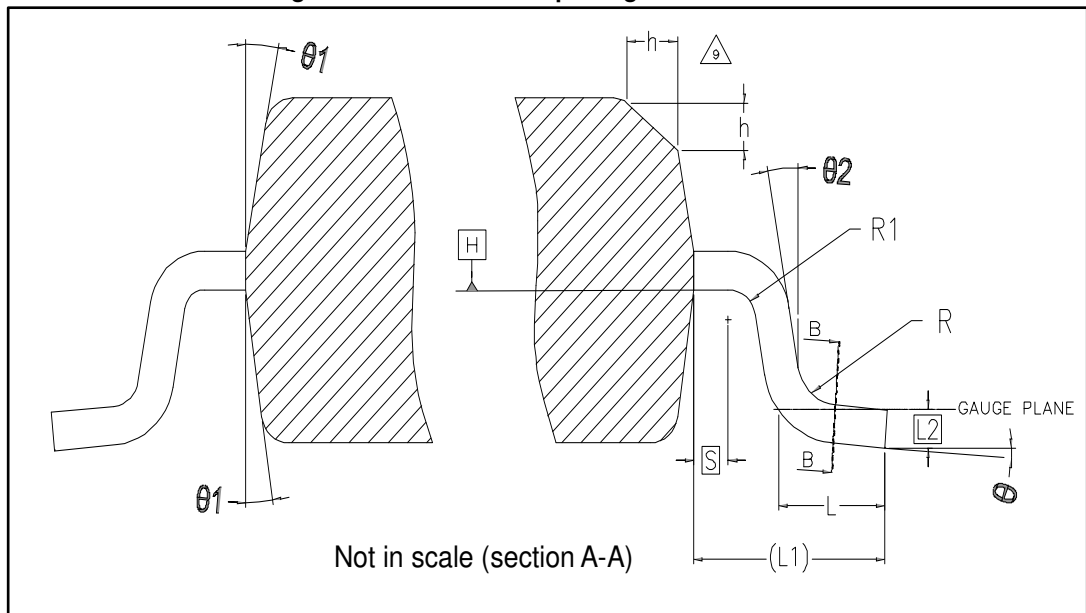

Figure 20: PowerSSO-36 package outline details (section B-B)

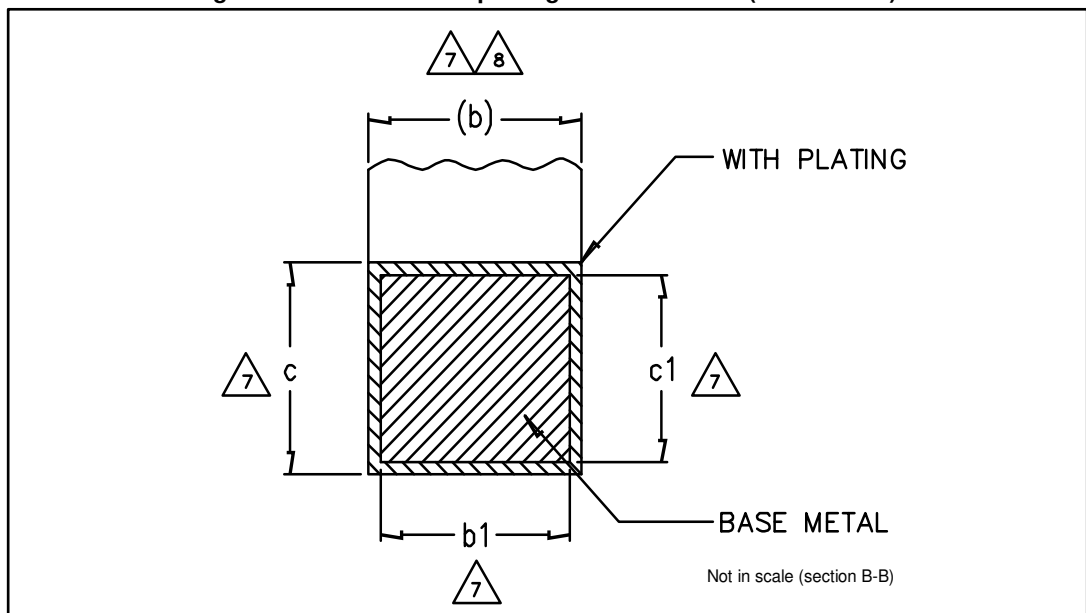

Table 19: PowerSSO-36 mechanical data

Dim.	mm		
	Min.	Typ.	Max.
e	0°		8°
e1	5°		10°
e2	0°		
A	2.15		2.45
A1	0.00		0.10
A2	2.15		2.35
b	0.18		0.32
b1	0.13	0.25	0.30
c	0.23		0.32
c1	0.20	0.20	0.30
D	10.30 BSC		
D1	7.00		7.40
D2		3.65	4.200
D3		4.30	
e		0.50 BSC	
E		10.30 BSC	
E1		7.50 BSC	
E2	4.20		4.60
E3		2.30	
E4		2.90	
G1		1.20	
G2		1.00	
G3		0.80	
h	0.30		0.40
L	0.60	0.70	0.85
L1		1.40 REF	
L2		0.25 BSC	
N		36	
R	0.30		
R1	0.20		
S	0.25		

17.2 PowerSSO-36 packing information

Figure 21: PowerSSO-36 tube shipment outline

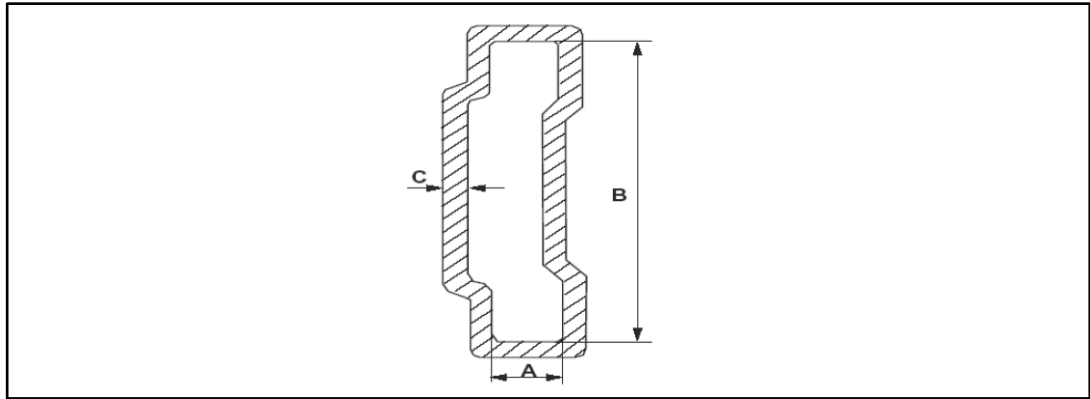

Table 20: PowerSSO-36 tube shipment mechanical data

Description	Value
Base quantity	49
Bulk quantity	1225
Tube length (± 0.5)	532
A	3.5
B	13.8
C (± 0.1)	0.6



All dimensions are in mm

Figure 22: PowerSSO-36 tape dimension outline

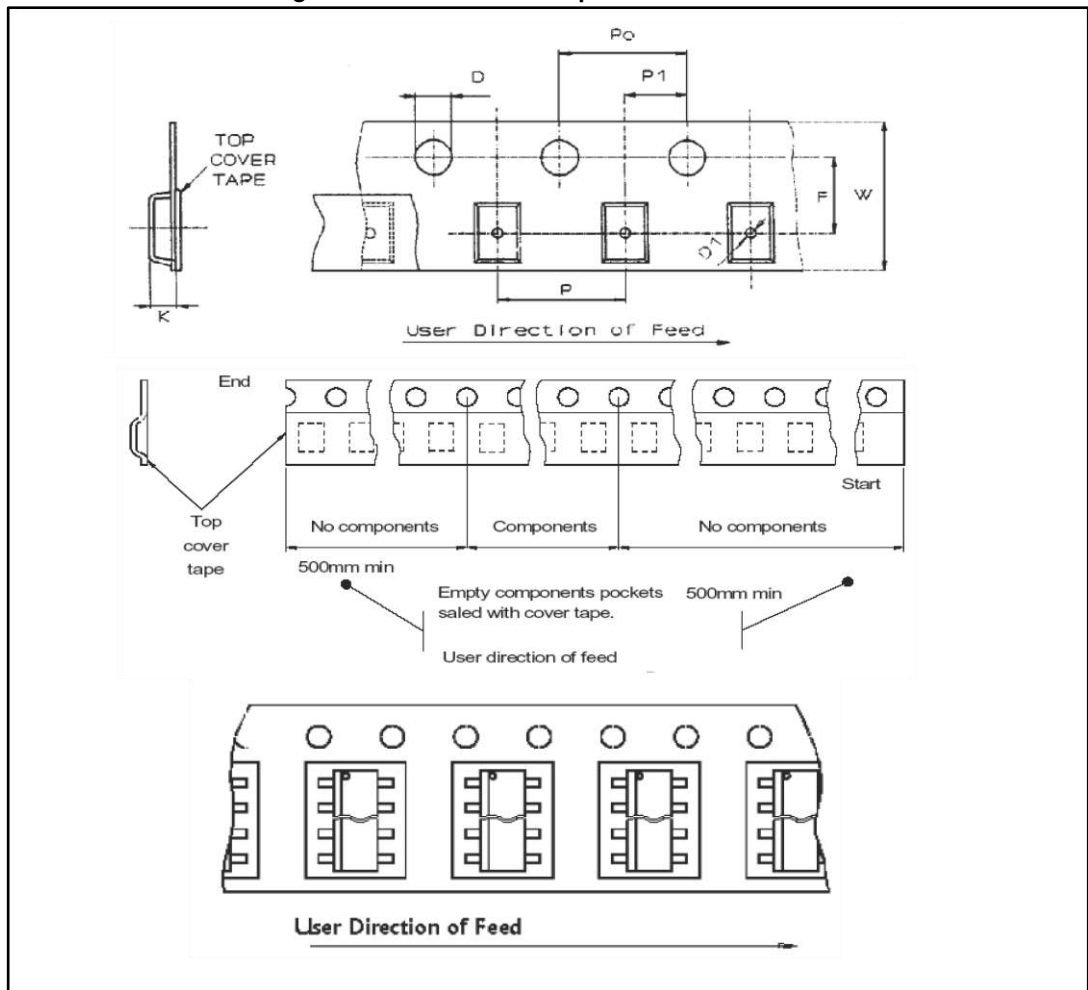

Table 21: PowerSSO-36 tape dimension mechanical data

Description	Dimensions	Value
Tape width	W	24
Tape hole spacing	P0 (± 0.1)	4
Component spacing	P	12
Hole diameter	D (± 0.05)	1.55
Hole diameter	D1 (min.)	1.5
Hole position	F (± 0.1)	11.5
Compartment depth	K (max.)	2.85
Hole spacing	P1 (± 0.1)	2



According to the Electronic Industries Association (EIA) standard 481 rev. A, Feb 1986

Figure 23: PowerSSO-36 reel shipment outline

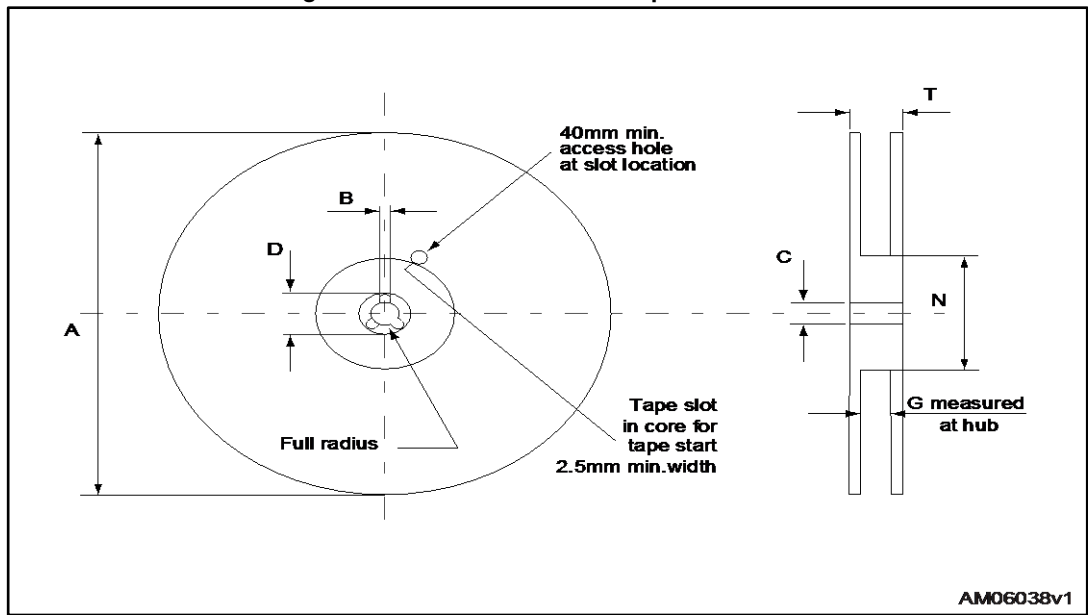

Table 22: PowerSSO-36 reel dimension mechanical data

Description	Value
Base quantity	1000
Bulk quantity	1000
A max.	330
B min.	1.5
C (± 0.2)	13
F	20.2
G (2 ± 0)	24.4
N min.	100
T min.	30.4

18 Revision history

Table 23: Document revision history

Date	Revision	Changes
04-Dec-2008	1	Initial release.
29-Apr-2009	2	Updated table 5.
19-Jun-2012	3	Updated: Features, Section 9.4, Section 9.7, Section 9.9, Section 9.10, Section 12, Table 2, Table 3, Table 5, Table 7, Table 8, Table 9, Table 10, Table 11, Table 14, Figure 1, Figure 2. Changed: Figure 6, Figure 7, Figure 8, Figure 17, Figure 17. Content reworked to improve the readability.
27-Jun-2012	4	Updated section 10.2.
08-Mar-2013	5	Updated Table 5, Table 9, Table 10, Table 14. Updated footnote 2. in Table 4. Updated Section 12. Added Section 6. Changed Figure 10 and Figure 11. Added Table 12. Changed product status to production data.
04-Dec-2013	6	Updated EAS parameter in Table 3: Absolute maximum ratings. Updated Section 6: Reverse polarity protection. Added Section 7: Demagnetization energy.
20-Feb-2014	7	Changed figure 4
30-Apr-2015	8	Updated package information section.
30-Jul-2015	9	Updated I_s parameter in power section table and protection and diagnostic table. Updated programmable watchdog time table.

IMPORTANT NOTICE – PLEASE READ CAREFULLY

STMicroelectronics NV and its subsidiaries ("ST") reserve the right to make changes, corrections, enhancements, modifications, and improvements to ST products and/or to this document at any time without notice. Purchasers should obtain the latest relevant information on ST products before placing orders. ST products are sold pursuant to ST's terms and conditions of sale in place at the time of order acknowledgement.

Purchasers are solely responsible for the choice, selection, and use of ST products and ST assumes no liability for application assistance or the design of Purchasers' products.

No license, express or implied, to any intellectual property right is granted by ST herein.

Resale of ST products with provisions different from the information set forth herein shall void any warranty granted by ST for such product.

ST and the ST logo are trademarks of ST. All other product or service names are the property of their respective owners.

Information in this document supersedes and replaces information previously supplied in any prior versions of this document.

© 2015 STMicroelectronics – All rights reserved