

PART NUMBER	REVISION	DESCRIPTION	FEED TYPE
2266564-1	B	FINE CRIMP HEIGHT ADJUST	MECHANICAL
2266564-2	B	FINE CRIMP HEIGHT ADJUST	PNEUMATIC
7-2266564-1	B	MECHANICAL AND CRIMP TOOLING KIT	MECHANICAL
7-2266564-2	B	PNEUMATIC AND CRIMP TOOLING KIT	PNEUMATIC
7-2266564-7	A	CRIMP TOOLING KIT	-

ATLANTIC VERSION TERMINATOR INTERFACE ADAPTER

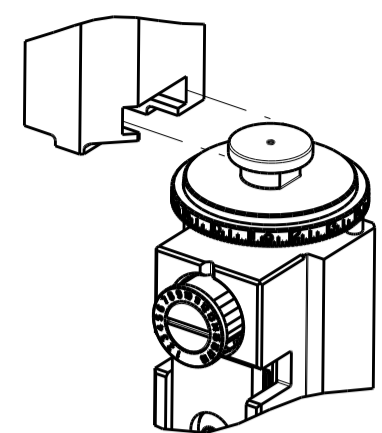

APPLICATOR DATA		
CRIMP	SIZE	TYPE
WIRE	1.60 mm [.063]	F
INSUL	3.00 mm [1.18]	O

APPLICATOR INSTRUCTIONS
408-35042

TERMINAL DATA: FCI/FORD/DELPHI TERMINAL FORD CRIMP SPECIFICATION	
TERMINAL NAME: TRMNL WIR SNP ON FEM	
WIRE STRIP LENGTH 4.92-5.68 mm [1.94-.224 IN]	TERMINAL INSULATION DIAMETER RANGE Ø
TERMINAL APPLICATION SPECIFICATION ESB-MIL-123 A/A2	

TERMINALS APPLIED				
TE TERMINAL	FCI/FORD/DELPHI TERMINAL	TE SEAL	FCI/FORD/DELPHI SEAL	SEAL INSULATION DIAMETER RANGE
2113610-1	5400-2006	2113424-1	AU5T-14603-EA	Ø 1.4-1.9
2113610-2	5400-2005	2113424-2	54200391	Ø 1.4-1.9
2113610-3	5400-2007			
2113610-4	F931400			
2113610-5	AU5T-14474-NA			
2113610-6	AU5T-14474-RA			
2113610-7	AU5T-14474-TA			
2113610-8	AU5T-14474-VA			
2113610-9	13827658			
1-2113610-0	13806233			
1-2113610-1	15521522			

WIRE SIZE 20 AWG OR 0.50mm2	CRIMP HEIGHT mm [INCH] 1.05+/-0.05 [.041+/- .002]	CRIMP HEIGHT REFERENCE SETTING 7.4
--------------------------------	--	---------------------------------------

- RECOMMENDED SPARE PARTS
- REFER TO SUPPLIED INSTRUCTION SHEET FOR CLEANING, LUBRICATION AND STORAGE OF APPLICATOR.
- APPLY PART NUMBER 2-23419-6 LOCTITE TO THREADS OF ITEM 242.
- CRIMP HEIGHT REFERENCE SETTING WAS THE SETTING USED WHEN THE APPLICATOR WAS QUALIFIED AT THE FACTORY. ADJUSTMENT MAY BE NECESSARY WHEN RUNNING APPLICATOR IN THE FIELD.
- UNLESS SPECIFIED OTHERWISE TORQUE VALUES SHALL BE USED PER DOCUMENT, 101-35000.
- APPLY TORQ-SEAL IN ALLEN SOCKET TO FILL HOLE AFTER FLAT HD HAS BEEN ADJUSTED TO CORRECT HEIGHT AT QUALIFICATION. APPLY #1-23419-5 LOC-TITE TO THREADS.

***WARNING**
ON INSTALLATION, SET WIRE DISC TO CRIMP HEIGHT REFERENCE SETTING FOR LARGEST WIRE SIZE. CRIMP HEIGHT REFERENCE SETTINGS GREATER THAN THE VALUE SHOWN MAY CAUSE DAMAGE TO THE CRIMP TOOLING, REFER TO THE INSTRUCTION SHEET FOR PROPER SETUP AND ADJUSTMENTS.

ATLANTIC VERSION
Shown on sheets 1 of 4 & 2 of 4
(Pacific version shown on sheets 3 of 4 & 4 of 4)

LOC	DIST	REVISIONS					
A	66	P	LTN	DESCRIPTION	DATE	OWN	APVD
		A		RELEASED	10DEC2014	KH	TE
		B		ECR-19-000895	18JAN2019	FJ	YY

-	1	-	1	-	2119640-1	PUSH ROD, AIR FEED	250
-	1	-	1	-	1803259-1	BUSHING, FLANGED	249
-	1	-	1	-	2119641-1	FEED CAM, AIR FEED	248
-	1	1	1	1	2119082-4	CAM, SNAIL, INSULATION ADJUSTMENT	244
-	1	1	1	1	2079764-1	WASHER, WAVE SPRING, CREST-TO-CREST	243
-	1	1	1	1	2119083-1	RETAINER, INSULATION DIAL	242
-	1	1	1	1	7-18023-7	SCR, SKT HD CAP M3 X 4.0	241
-	-	1	-	1	2119580-1	MECHANICAL FEED ASSEMBLY	239
-	1	-	1	-	2063440-1	AIR FEED MODULE	238
-	2	-	2	-	21045-3	RING, RETAIN, EXTERN, 3/16 CRESCENT	172
-	REF	REF	REF	REF	994970-2	COUNTER, MAGNETIC	164
-	1	-	1	-	240638-1	SPRING, FEED FINGER	163
-	1	-	1	-	3-23627-7	PIN, RETAIN, GRVD, 3/16 X .854	137
-	1	-	1	-	2119799-1	HOLDER, FEED FINGER, AF	136
-	1	1	1	1	2844908-1	SCREW, LOCKING	99
-	1	1	1	1	2844907-1	POST, LOCKING	98
-	1	1	1	1	455888-5	SPACER, CRIMPER	82
-	1	1	1	1	1803607-1	DOCUMENTATION PACKAGE	71
-	1	1	1	1	2119740-1	TAG, IDENTIFICATION	67
-	2	2	2	2	2168078-1	SCREW, DRIVE, RH, RoHS, 2 x .188	66
-	1	1	1	1	2168083-2	SCR, SKT HD CAP, RoHS, M4 X 8.0	60
-	1	1	1	1	5-18022-5	SCR, HEX HD CAP, M4 X 6.0	59
-	1	1	1	1	985575-3	SCR, FLT SKT HD CAP M3 X 10.0	57
-	1	1	1	1	1338685-1	PAWL, FEED	56
-	4	4	4	4	2168083-3	SCR, SKT HD CAP, RoHS, M4 X 12.0	54
-	2	2	2	2	1-2168083-0	SCR, SKT HD CAP, RoHS, M4 X 10	53
-	1	1	1	1	5018030-1	NUT, HEX, REG, RoHS, M3	52
-	1	1	1	1	811242-5	BUMPER, HOLD DOWN	51
-	1	1	1	1	690753-2	SPACER, TONKER	50
-	1	2	1	2	18023-9	SCR, SKT HD CAP M4 X 6.0	49
-	-	1	-	1	2119652-1	FEED CAM, PRE FEED	48
-	-	1	-	1	2119653-1	FEED CAM, POST FEED	47
-	1	1	1	1	1803583-9	APPLICATOR BASIC ASSEMBLY, SF	46
-	1	1	1	1	1803515-1	RAM ASSEMBLY, SF ATLANTIC	44
-	1	1	1	1	1803602-1	SCR, BHSC, RoHS (M8 X 25)	41
-	1	1	1	1	3-1752356-4	SUPPORT, TERMINAL	34
-	2	2	2	2	2079383-5	SCR, BHSC, RoHS (M4 X 20)	33
-	2	2	2	2	3-2844962-0	SPACER, CYLINDRICAL, STRIP GUIDE	30
-	1	1	1	1	2844992-1	ASSEMBLY, STRIP GUIDE	29
-	1	1	1	1	455888-3	SPACER, CRIMPER	28
-	1	1	1	1	1320928-2	STRIP GUIDE	24
-	1	1	1	1	2168083-2	SCR, SKT HD CAP, RoHS, M4 X 8.0	21
-	2	2	2	2	1-18028-2	WASHER, FLAT, REG M4	20
-	1	1	1	1	2119533-1	STRIPPER, SIDE FEED	19
-	1	1	1	1	2119806-1	INSERT, SHEAR	13
-	1	1	1	1	3-22280-3	SPRING, COMPRESSION	12
-	1	1	1	1	1-356885-4	STOP, SHEAR	11
-	1	1	1	1	2119805-1	SHEAR HOLDER, FRONT	10
-	1	1	1	1	318707-1	FLOATING SHEAR, FRONT	9
1	2	2	1	1	1-1803171-9	ANVIL, COMBINATION	8
-	-	-	-	-	-	-	7
-	-	-	-	-	-	-	6
-	1	1	1	1	2119781-1	DEPRESSOR, SHEAR	5
-	1	1	1	1	238011-4	BLOCK, CRIMPER SPACER	4
1	2	2	1	1	7-1633965-9	CRIMPER, INSULATION O PREMIUM	3
-	1	1	1	1	1-455888-4	SPACER, CRIMPER	2
1	2	2	1	1	8-1633588-3	CRIMPER, WIRE	1

DIMENSIONS:		TOLERANCES UNLESS OTHERWISE SPECIFIED:		MATERIAL:		FINISH:		WEIGHT:		SCALE:	
mm	0 PLC ±	1 PLC ±	2 PLC ±	3 PLC ±	4 PLC ±	ANGLES ±					
APPLICATOR NAME		APPLICATOR SPEC		CAGE CODE		DRAWING NO		RESTRICTED TO		SHEET	
Ocean Side Feed Applicator				A1		00779		Customer Accessible Production Drawing		1 of 4	

LOC	DIST	REVISIONS					
		P	LTN	DESCRIPTION	DATE	DWN	APVD
A	66	-	-	SEE SHEET 1	-	-	-

FEED TYPE MECHANICAL



PNEUMATIC

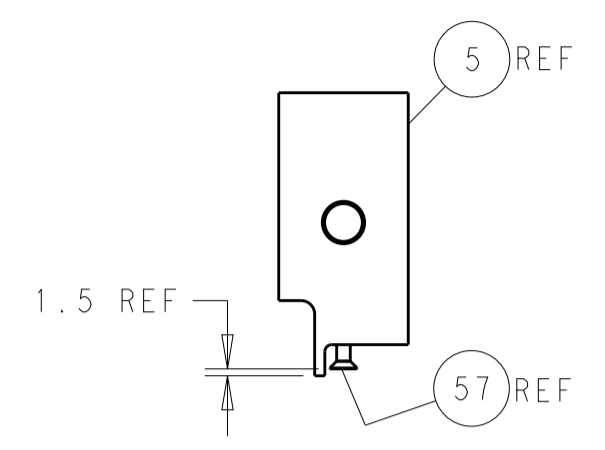
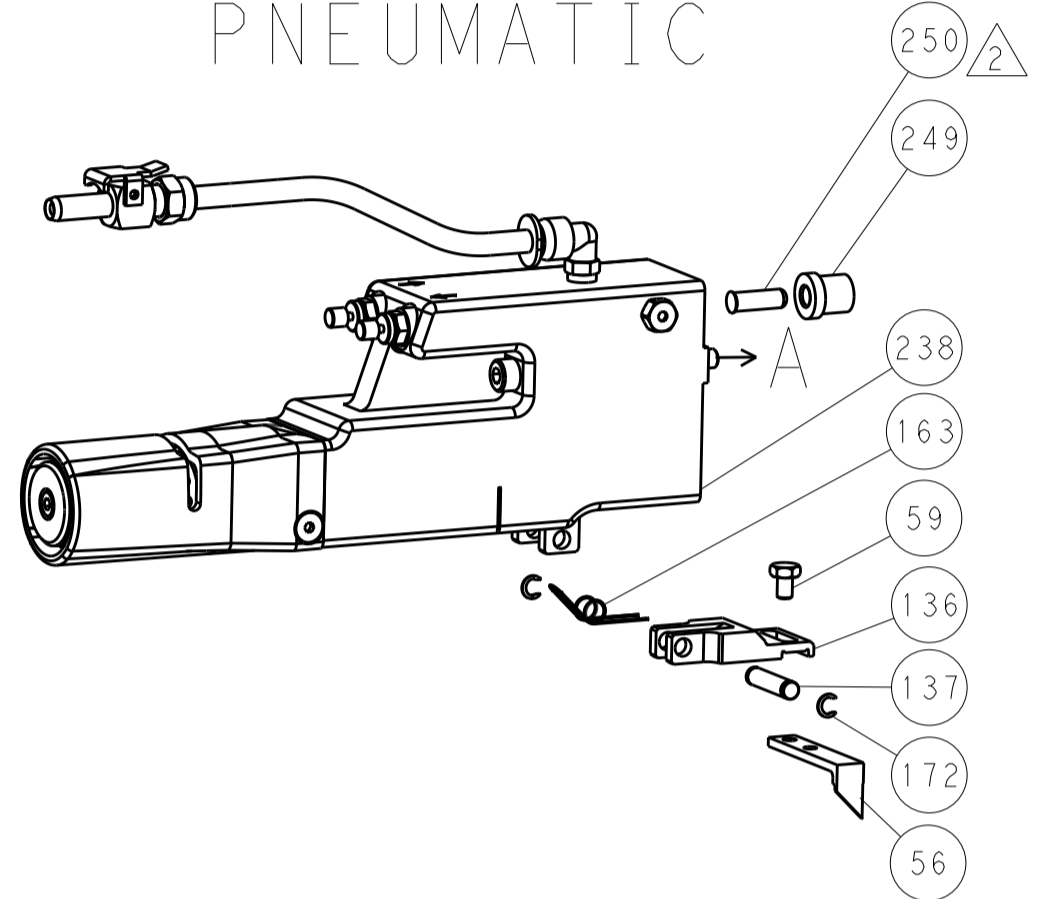

SHEAR DEPRESSOR DETAIL

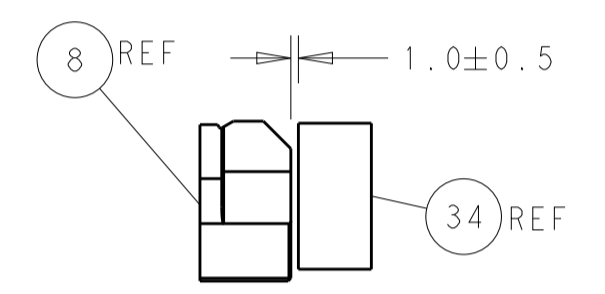

TERMINAL SUPPORT LOCATION

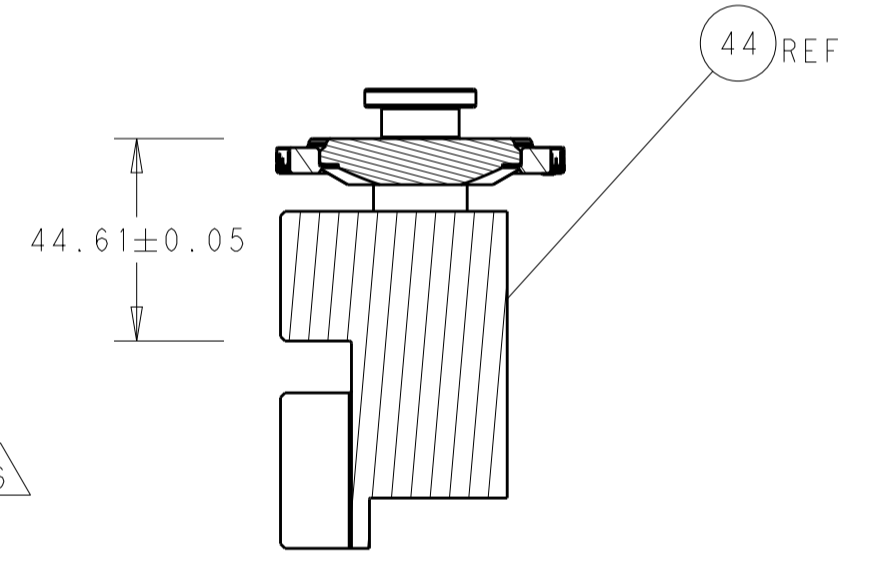

RAM SET-UP

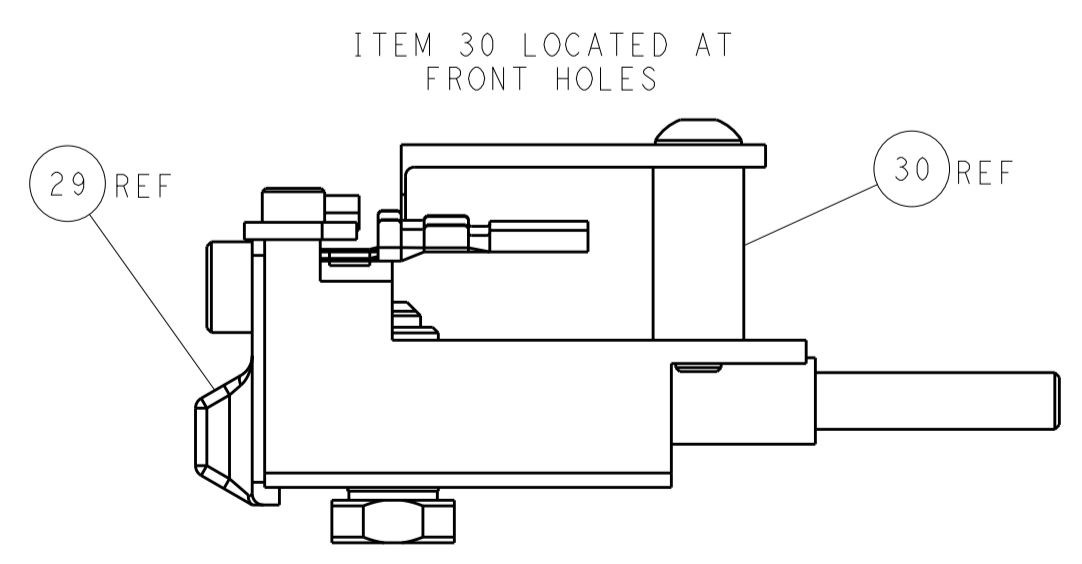

FEED TRACK POSITION GUIDE BY INSULATION BARREL

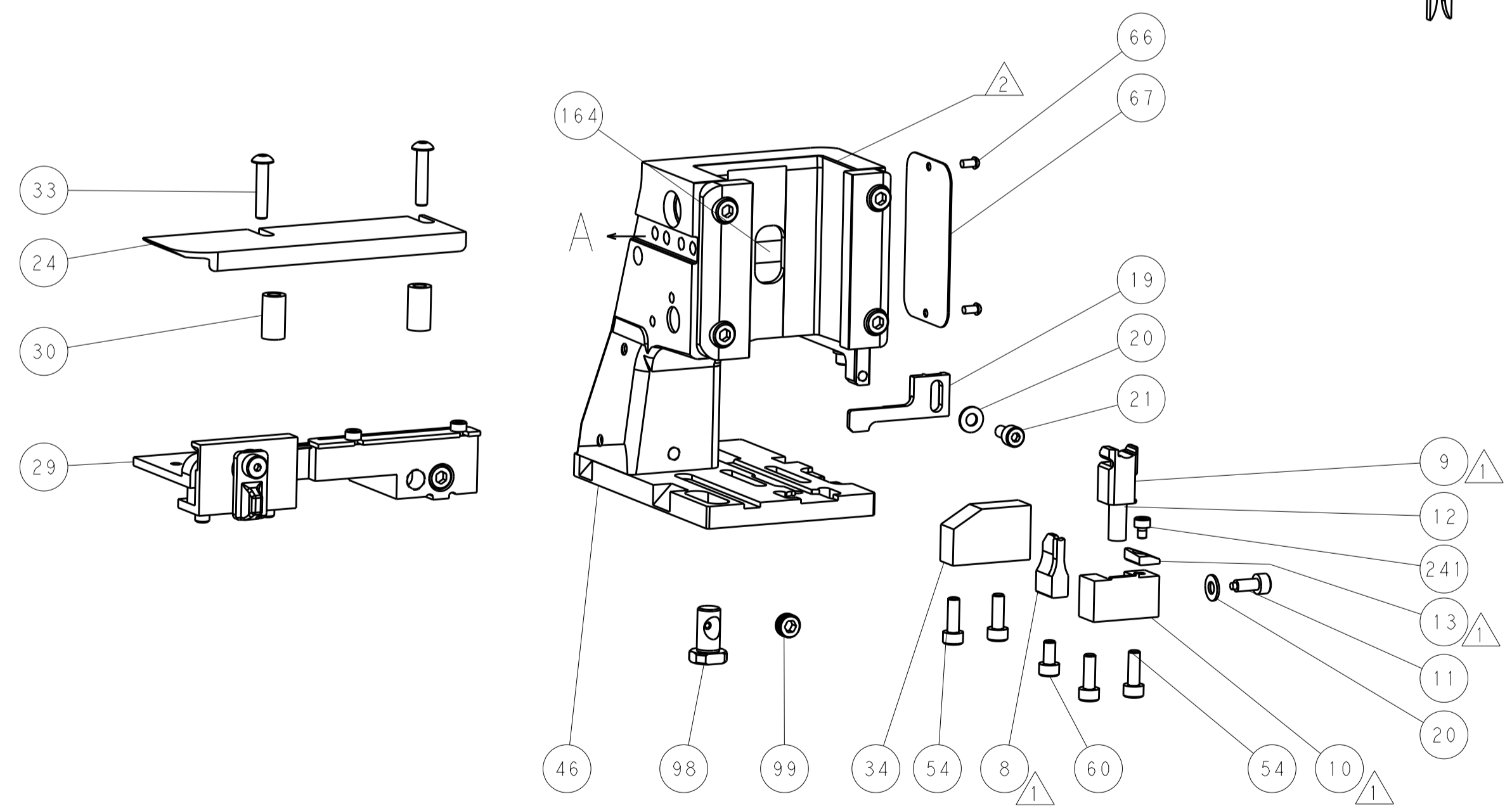
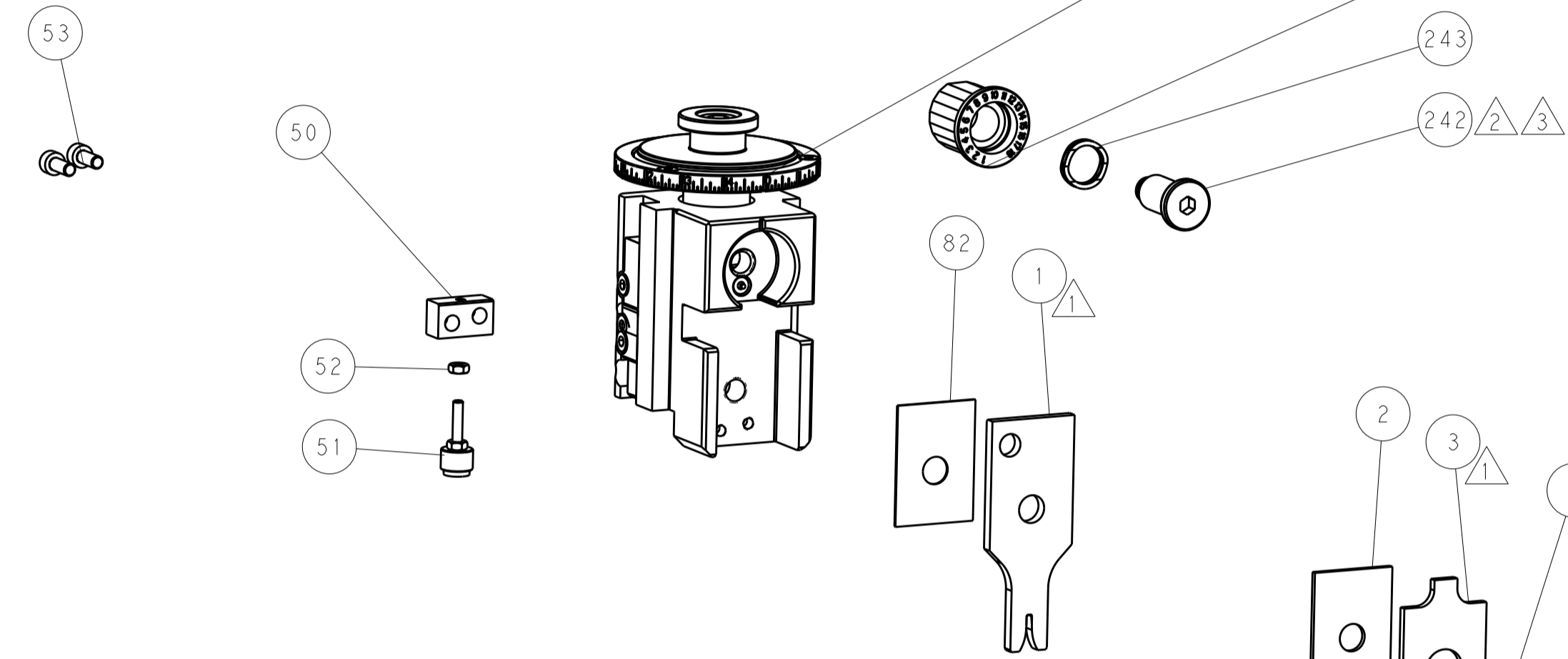

CAM POSITIONS

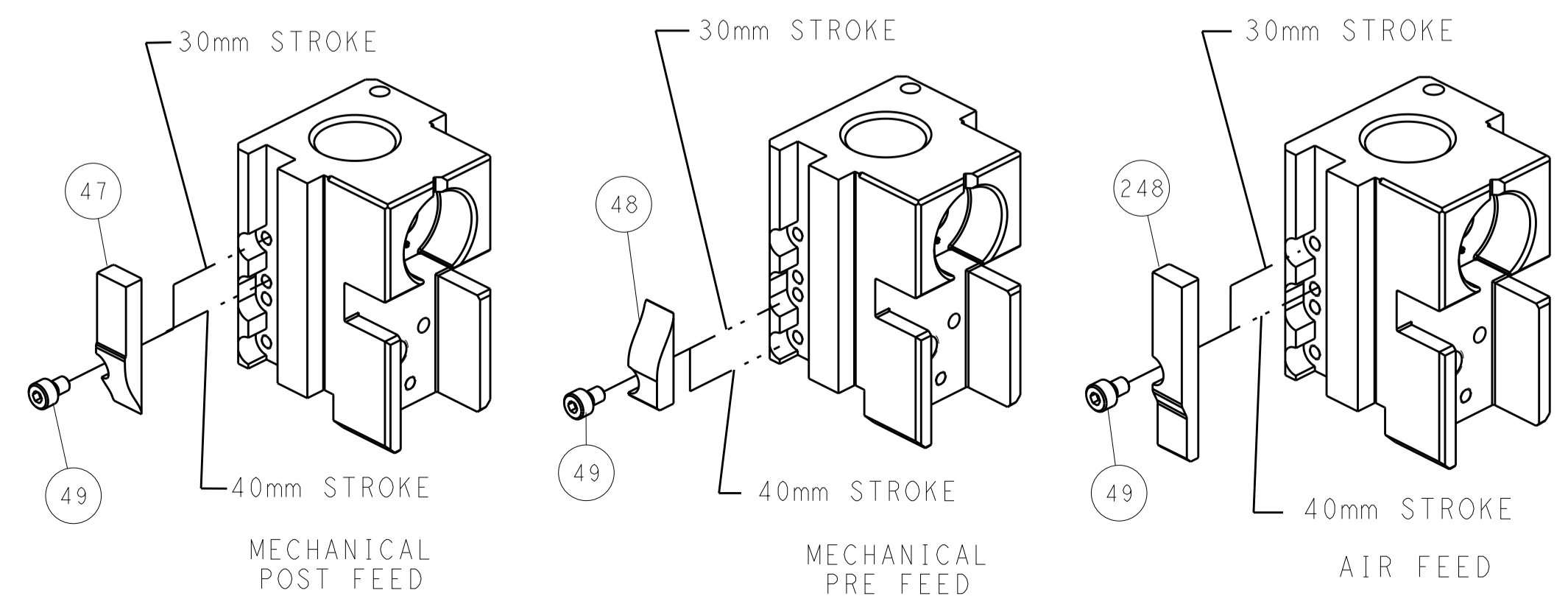

ATLANTIC VERSION
 Shown on sheets 1 of 4 & 2 of 4
 (Pacific version shown on sheets 3 of 4 & 4 of 4)

DIMENSIONS: mm 		TOLERANCES UNLESS OTHERWISE SPECIFIED: 0 PLC ± 1 PLC ± 2 PLC ± 3 PLC ± 4 PLC ± ANGLES ±		DWN H. HUANG 04NOV2014 CHK L. ZHANG 04NOV2014 APVD H. GUO 04NOV2014 NAME Ocean Side Feed Applicator SIZE CAGE CODE DRAWING NO. RESTRICTED TO A1 00779 ©=2266564 Customer Accessible Production Drawing SCALE 1:2 SHEET 2 OF 4 REV B	
MATERIAL:		FINISH:		WEIGHT:	

PART NUMBER	REVISION	DESCRIPTION	FEED TYPE
2-2266564-1	B	FINE CRIMP HEIGHT ADJUST	MECHANICAL
2-2266564-2	B	FINE CRIMP HEIGHT ADJUST	PNEUMATIC
7-2266564-7	A	CRIMP TOOLING KIT	-

PACIFIC VERSION TERMINATOR
 INTERFACE ADAPTER

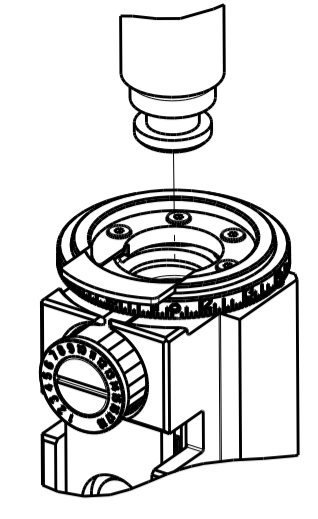

APPLICATOR DATA		
CRIMP	SIZE	TYPE
WIRE	1.60 mm [.063]	F
INSUL	3.00 mm [.118]	O

APPLICATOR INSTRUCTIONS
 408-35042

TERMINAL DATA: FCI/FORD/DELPHI TERMINAL FORD CRIMP SPECIFICATION	
TERMINAL NAME: TRMNL WIR SNP ON FEM	
WIRE STRIP LENGTH 4.92-5.68 mm [1.94-.224 IN]	TERMINAL INSULATION DIAMETER RANGE Ø
TERMINAL APPLICATION SPECIFICATION ESB-MIL-123 A/A2	

TE TERMINAL	FCI/FORD/DELPHI TERMINAL	TE SEAL	FCI/FORD/DELPHI SEAL	SEAL INSULATION DIAMETER RANGE
2113610-1	5400-2006	2113424-1	AUST-14603-EA	Ø1.4-1.9
2113610-2	5400-2005	2113424-2	54200391	Ø1.4-1.9
2113610-3	5400-2007			
2113610-4	F931400			
2113610-5	AUST-14474-NA			
2113610-6	AUST-14474-RA			
2113610-7	AUST-14474-TA			
2113610-8	AUST-14474-VA			
2113610-9	13827658			
1-2113610-0	13806233			
1-2113610-1	15521522			

WIRE SIZE	CRIMP HEIGHT mm [INCH]	CRIMP HEIGHT REFERENCE SETTING
20 AWG OR 0.50mm2	1.05+/-0.05 [.041+/-0.002]	7.4



- 1 RECOMMENDED SPARE PARTS
- 2 REFER TO SUPPLIED INSTRUCTION SHEET FOR CLEANING, LUBRICATION AND STORAGE OF APPLICATOR.
- 3 APPLY PART NUMBER 2-23419-6 LOCTITE TO THREADS OF ITEM 242.
- 4 CRIMP HEIGHT REFERENCE SETTING WAS THE SETTING USED WHEN THE APPLICATOR WAS QUALIFIED AT THE FACTORY. ADJUSTMENT MAY BE NECESSARY WHEN RUNNING APPLICATOR IN THE FIELD.
- 5 UNLESS SPECIFIED OTHERWISE TORQUE VALUES SHALL BE USED PER DOCUMENT, 101-35000.
- 6 APPLY TORO-SEAL IN ALLEN SOCKET TO FILL HOLE AFTER FLAT HD HAS BEEN ADJUSTED TO CORRECT HEIGHT AT QUALIFICATION. APPLY #1-23419-5 LOC-TITE TO THREADS.

***WARNING**
 ON INSTALLATION, SET WIRE DISC TO CRIMP HEIGHT REFERENCE SETTING FOR LARGEST WIRE SIZE. CRIMP HEIGHT REFERENCE SETTINGS GREATER THAN THE VALUE SHOWN MAY CAUSE DAMAGE TO THE CRIMP TOOLING, REFER TO THE INSTRUCTION SHEET FOR PROPER SETUP AND ADJUSTMENTS.

LOC	DIST	REV	DATE	BY	APPV
A	66				

REV	DATE	BY	APPV	DESCRIPTION	ITEM NO
-	1	-		2119640-1 PUSH ROD, AIR FEED	250
-	1	-		1803259-1 BUSHING, FLANGED	249
-	1	1		2119082-4 CAM, SNAIL, INSULATION ADJUSTMENT	244
-	1	1		2079764-1 WASHER, WAVE SPRING, CREST-TO-CREST	243
-	1	1		2119083-1 RETAINER, INSULATION DIAL	242
-	1	1		7-18023-7 SCR, SKT HD CAP M3 X 4.0	241
-	-	1		2119580-1 MECHANICAL FEED ASSEMBLY	239
-	1	-		2063440-1 AIR FEED MODULE	238
-	2	-		21045-3 RING, RETAIN, EXTERN, 3/16 CRESCENT	172
-	REF	REF		994970-2 COUNTER, MAGNETIC	164
-	1	-		240638-1 SPRING, FEED FINGER	163
-	1	-		2119641-2 FEED CAM, AIR FEED	151
-	1	1		2168083-8 SCR, SKT HD CAP, RoHS, M4 X 16	144
-	4	4		2168083-9 SCR, SKT HD CAP, RoHS, M4 X 20	143
-	-	1		2119653-2 FEED CAM, POST FEED	142
-	1	1		1-1803583-0 APPLICATOR BASIC ASSEMBLY, SF	141
-	1	1		1803516-1 RAM ASSEMBLY, SF PACIFIC	140
-	1	-		3-23627-7 PIN, RETAIN, GRVD, 3/16 X .854	137
-	1	-		2119799-1 HOLDER, FEED FINGER, AF	136
-	1	1		2844908-1 SCREW, LOCKING	99
-	1	1		2844907-1 POST, LOCKING	98
-	1	1		455888-5 SPACER, CRIMPER	82
-	1	1		1803607-1 DOCUMENTATION PACKAGE	71
-	1	1		2119740-1 TAG, IDENTIFICATION	67
-	2	2		2168078-1 SCREW, DRIVE, RH, RoHS, 2 x .188	66
-	1	1		5-18022-5 SCR, HEX HD CAP, M4 X 6.0	59
-	1	1		985575-3 SCR, FLT SKT HD CAP M3 X 10.0	57
-	1	1		1338685-1 PAWL, FEED	56
-	2	2		1-2168083-0 SCR, SKT HD CAP, RoHS, M4 X 10	53
-	1	1		5018030-1 NUT, HEX, REG, RoHS, M3	52
-	1	1		811242-5 BUMPER, HOLD DOWN	51
-	1	1		690753-2 SPACER, TONKER	50
-	1	2		18023-9 SCR, SKT HD CAP M4 X 6.0	49
-	-	1		2119652-1 FEED CAM, PRE FEED	48
-	1	1		1803602-1 SCR, BHSC, RoHS (M8 X 25)	41
-	1	1		3-1752356-4 SUPPORT, TERMINAL	34
-	2	2		2079383-5 SCR, BHSC, RoHS (M4 X 20)	33
-	2	2		3-2844962-0 SPACER, CYLINDRICAL, STRIP GUIDE	30
-	1	1		2844992-1 ASSEMBLY, STRIP GUIDE	29
-	1	1		455888-3 SPACER, CRIMPER	28
-	1	1		1320928-2 STRIP GUIDE	24
-	1	1		2168083-2 SCR, SKT HD CAP, RoHS, M4 X 8.0	21
-	2	2		1-18028-2 WASHER, FLAT, REG M4	20
-	1	1		2119533-1 STRIPPER, SIDE FEED	19
-	1	1		2119806-1 INSERT, SHEAR	13
-	1	1		3-22280-3 SPRING, COMPRESSION	12
-	1	1		1-356885-4 STOP, SHEAR	11
-	1	1		2119805-1 SHEAR HOLDER, FRONT	10
-	1	1		318707-1 FLOATING SHEAR, FRONT	9
1	1	1		1-1803171-9 ANVIL, COMBINATION	8
-	-	-		-	7
-	-	-		-	6
-	1	1		2119781-1 DEPRESSOR, SHEAR	5
-	1	1		238011-4 BLOCK, CRIMPER SPACER	4
1	1	1		7-1633965-9 CRIMPER, INSULATION O PREMIUM	3
-	1	1		1-455888-4 SPACER, CRIMPER	2
1	1	1		8-1633588-3 CRIMPER, WIRE	1

PACIFIC VERSION
 Shown on sheets 3 of 4 & 4 of 4
 (Atlantic version shown on sheets 1 of 4 & 2 of 4)

DIMENSIONS: mm		TOLERANCES UNLESS OTHERWISE SPECIFIED:		DWG: H. HUANG 04NOV2014		CHK: L. ZHANG 04NOV2014		APVD: J. GUO 04NOV2014		NAME: Ocean Side Feed Applicator	
MATERIAL: -		FINISH: -		PRODUCT SPEC: -		APPLICATION SPEC: -		SIZE: A1		CAGE CODE: 00779	
Customer Accessible Production Drawing		SCALE: 1:2		SHEET: 3 OF 4		REV: B		DRAWING NO: 2266564		DATE: 04NOV2014	

LOC	DIST	REVISIONS					
		P	LTN	DESCRIPTION	DATE	DWN	APVD
A	66	-	-	SEE SHEET 1	-	-	-

FEED TYPE MECHANICAL



PNEUMATIC

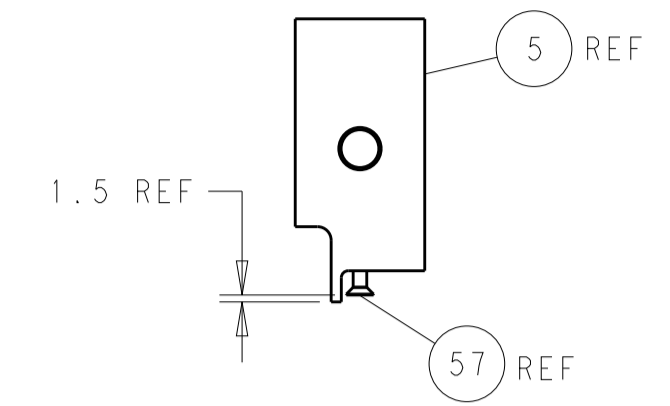
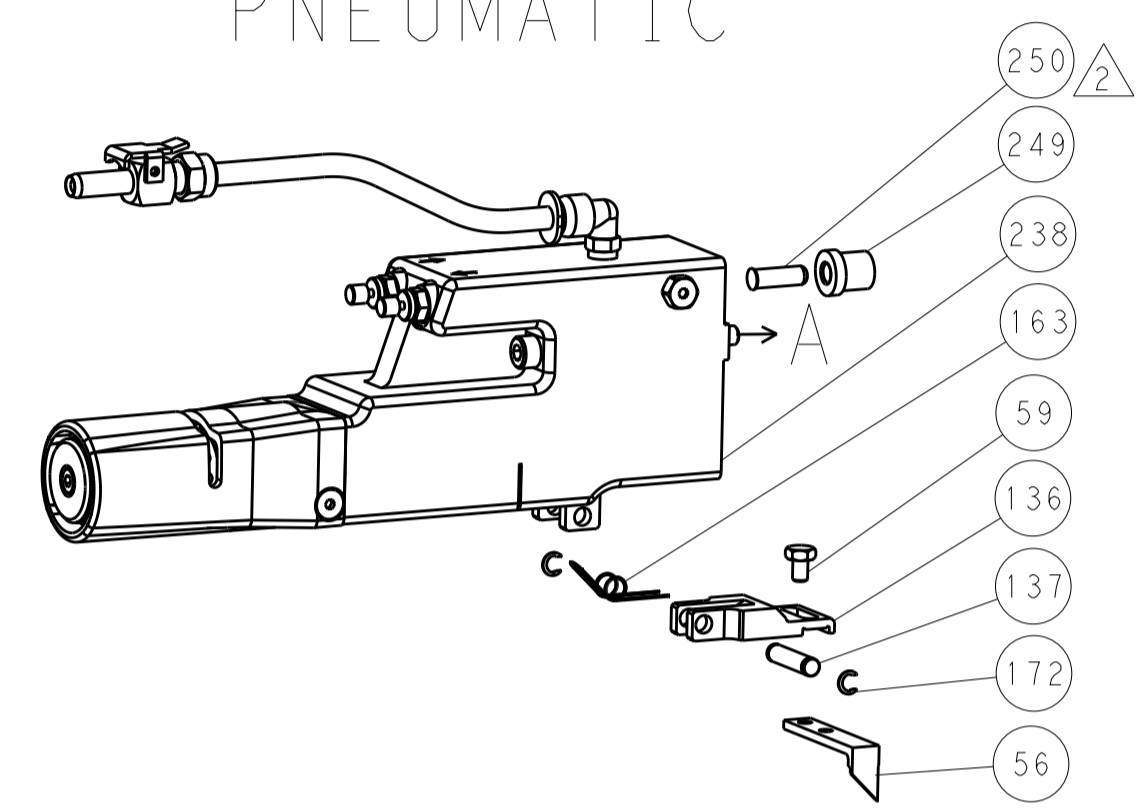

SHEAR DEPRESSOR DETAIL

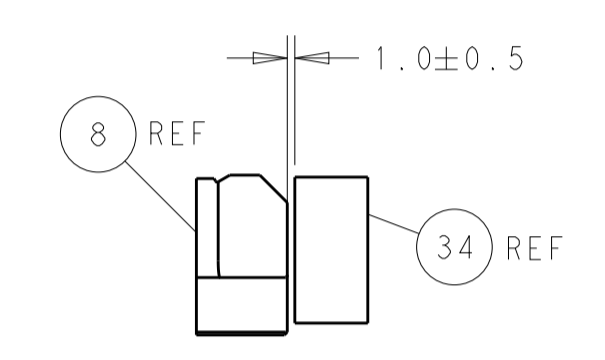

TERMINAL SUPPORT LOCATION

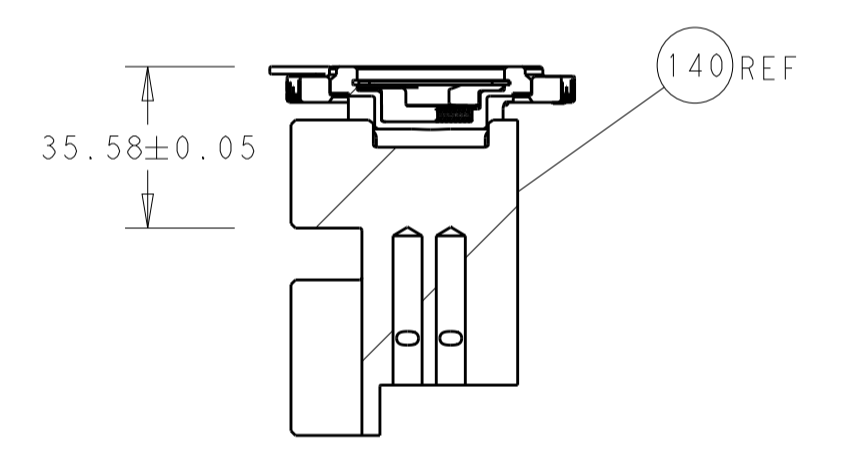

RAM SET-UP

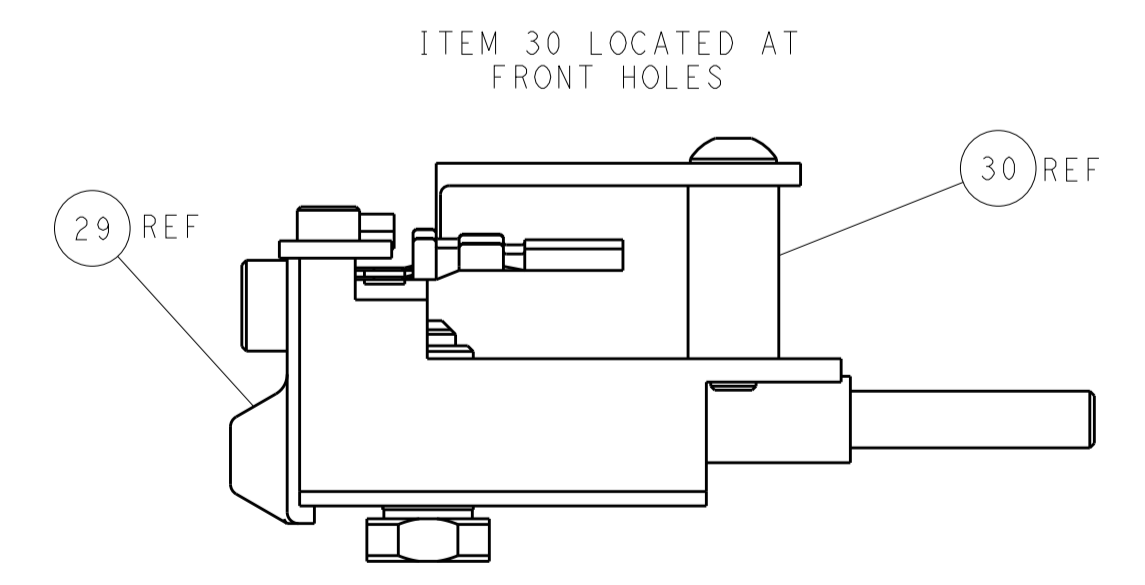

FEED TRACK POSITION
GUIDE BY INSULATION BARREL

CAM POSITIONS

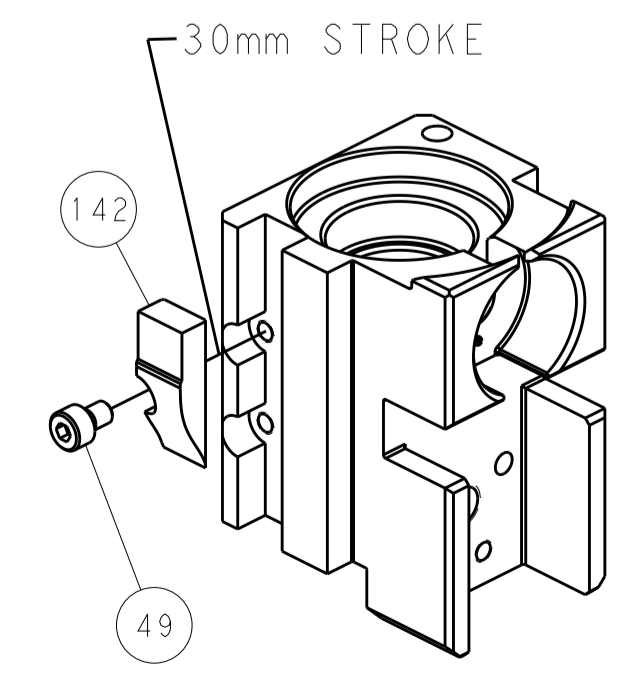

MECHANICAL
POST FEED

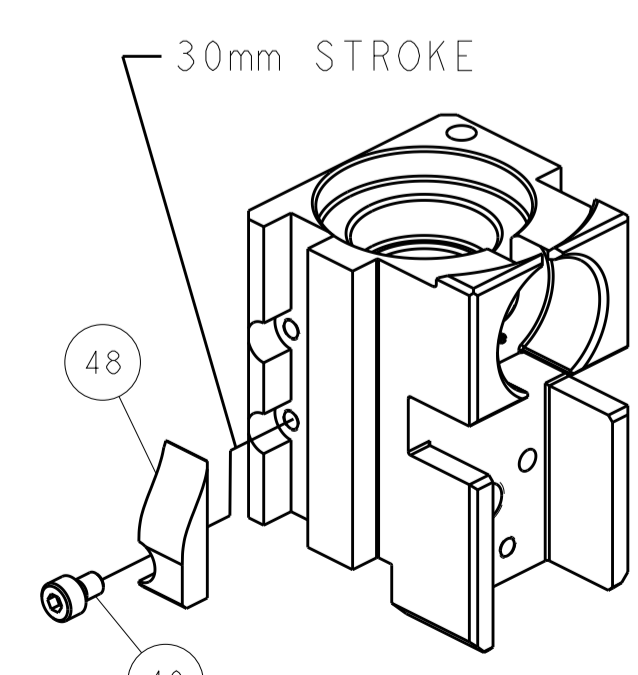

MECHANICAL
PRE FEED

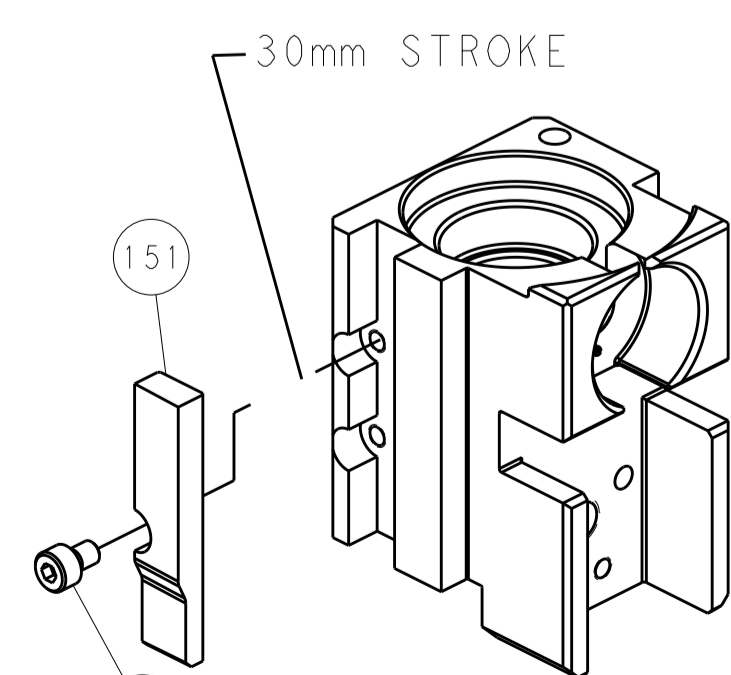

AIR FEED

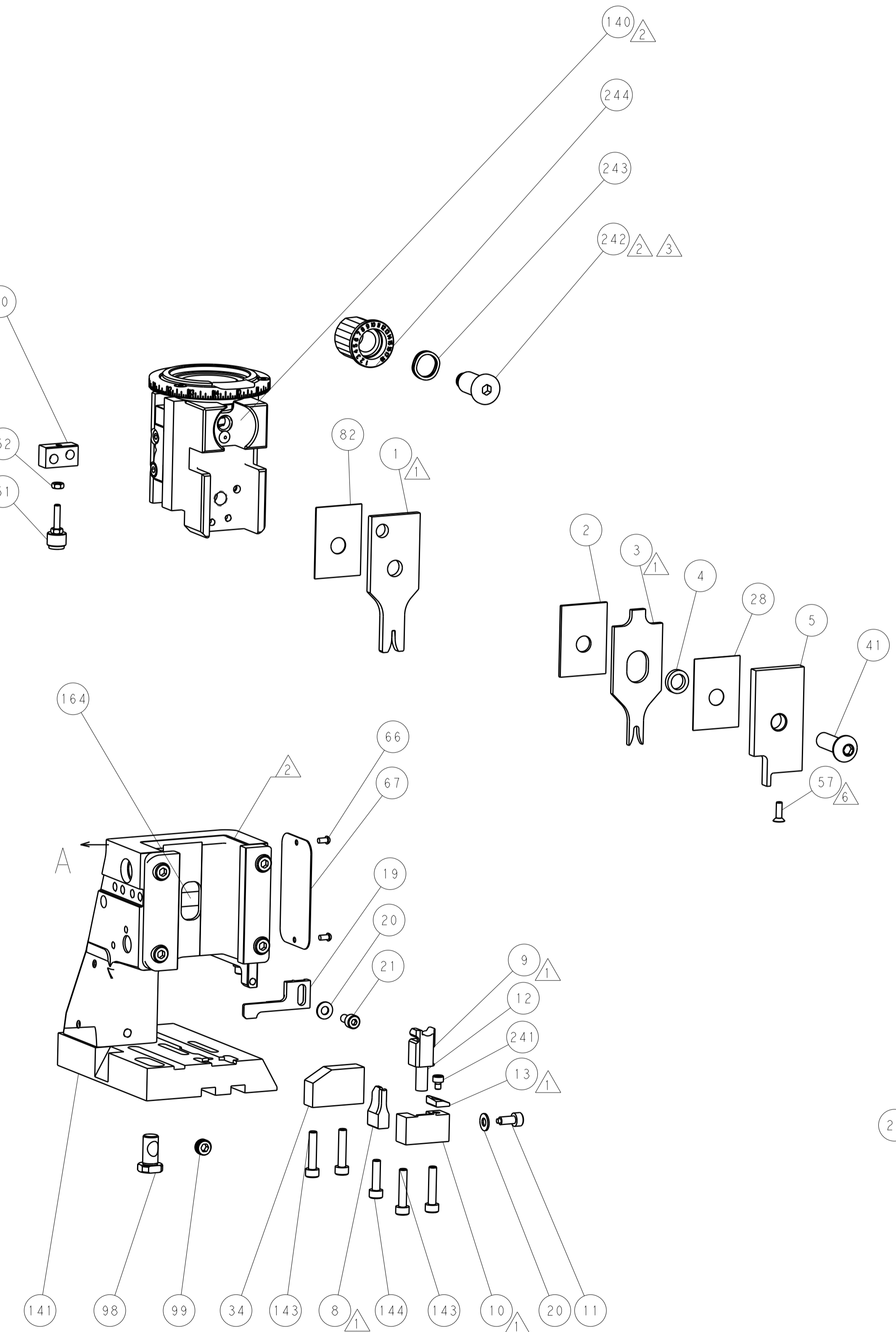

PACIFIC VERSION
 Shown on sheets 3 of 4 & 4 of 4
 (Atlantic version shown on sheets 1 of 4 & 2 of 4)

DIMENSIONS:		TOLERANCES UNLESS OTHERWISE SPECIFIED:		DWN R. HUANG 04NOV2014		TE Connectivity	
mm	0 PLC ±	1 PLC ±	2 PLC ±	3 PLC ±	4 PLC ±	5 PLC ±	Harrisburg, PA 17105-3608
MATERIAL:		FINISH:		CHK L. ZHANG 04NOV2014		NAME	
				APVD H. GUO 04NOV2014		Ocean Side Feed Applicator	
				PRODUCT SPEC		SIZE CAGE CODE DRAWING NO	
				APPLICATION SPEC		A1 00779 C=2266564	
				WEIGHT		RESTRICTED TO	
				Customer Accessible Production Drawing		SCALE 1:2 SHEET 4 OF 4 REV B	