

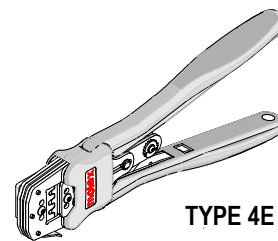

**HAND CRIMP
TOOL**

**Application Tooling
Specification Sheet**



TYPE 4E

Order No. 63827-1200

FEATURES

- A full cycle ratcheting hand tool ensures complete crimps
- Ergonomic soft grip handles for comfortable crimping
- A precision user-friendly terminal locator wire stop holds terminals in the proper crimping position
- Right and Left handed applications
- This tool is IPC/WHMA A-620 Class 2 compliant
- This tool is RoHS compliant, however RoHS compliant is not required

SCOPE

Products, Quick Disconnect, Female Crimp Terminal for 1.00-2.50mm²

Terminal Series No.	Terminal Order No.		Wire Size		Insulation Diameter Max.(2)		Strip Length	
	Reel Form only (1)		mm ²	AWG	mm	In.	mm	In.
94030	94030-3910	94030-3911	1.00-2.50	-	3.70	.146	5.30-6.30	.209-.248
	94030-3912	94030-3913						

(1) Customer to cut off terminal from reel: 0.30mm (.012") maximum cut-off tab (both ends)
 (2) To achieve optimum IPC-A620 insulation crimps, use insulation OD range: 2.40-3.70mm (.095"-.146")

DEFINITION OF TERMS

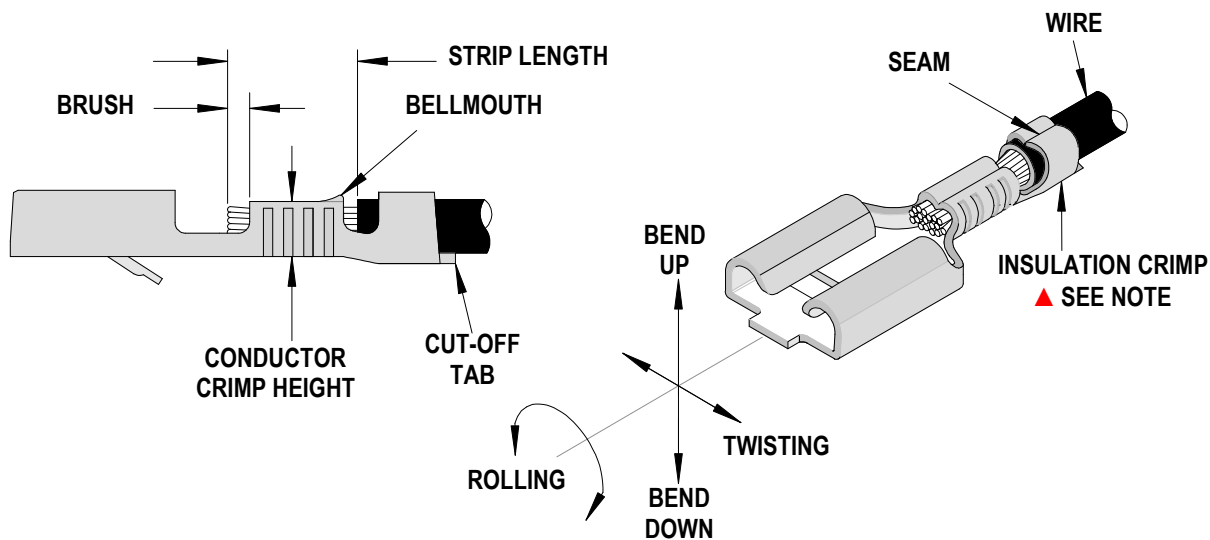

CONDITIONS:

Terminal Series No.	Bell mouth		Conductor Brush	
	mm	In.	mm	In.
94030	0.30-0.60	.012-.024	0.30-1.00	.012-.039

Terminal Series No.	Bend up	Bend down	Twist Roll		Seam Seam shall not be open and no wire allowed out of the crimping area
	Degree Max.		Degree Max.		
94030	3	3	4	8	

After crimping, the conductor profiles should measure the following.

Terminal Series No.	Wire Size		Conductor Crimp				Insulation Crimp				Pull Force Minimum		Profile		
			Height		Width Max.		Height (Ref.)		Width (Ref.)				1.5mm2	2.5mm2	1.0mm2
	mm ²	AWG	mm	In.	mm	In.	mm	In.	mm	In.	N	Lb.			
94030	1.00	-	1.50-1.60	.059-.063	2.95	.116	3.15	.124	3.50	.138	156.8	35.3			X
	1.50	-	1.65-1.75	.065-.069	2.95	.116	3.45	.136	3.75	.148	196.0	44.1	X		
	2.50	-	1.77-1.87	.070-.074	2.95	.116	3.60	.142	4.10	.161	245.0	55.1		X	

Tool Qualification Notes:

1. Pull Force should be measured with no influence from the insulation crimp.
2. The above specifications are guidelines to an optimum crimp.

▲ Insulation Crimp Note:

Due to the terminal's insulation grip design and/or insulation diameter range, this tool uses "overlap" form geometry in the insulation punch. This produces an overlap insulation crimp (A620 – compliant). While the insulation punch profile may appear "lopsided", this is a normal condition for this tool. See figure to the right.

(Some tools with multiple crimp pockets may not have the "overlap" profile on all pockets).

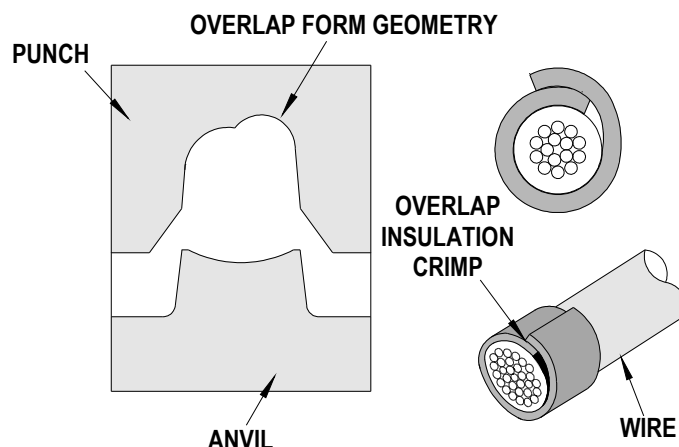

CAUTION: Install only Molex terminals listed above with this tool. Do not crimp hardened objects as damage can occur to the tool or die.

Note:

A crimp height chart is provided with this manual as Reference Only. Due to the wide range of wires, strands, insulation diameters, and durometers available, actual crimp height measurements may vary slightly. An occasional, destructive, pull force test should be performed to check hand tool crimp. Pull Force value Must exceed the Minimum pull force specifications listed.

OPERATION

Open the tool by squeezing the handles together. At the end of the closing stroke, the ratchet mechanism will release the handles and the hand tool will spring open. See Figure 1.

Crimping Terminals

1. Select the desired terminal listed in the preceding charts.
2. Push the wire stop lever on the side of the hand tool to raise the wire stop up before inserting the terminal in the hand tool. See Figure 2.
3. With the wire stop lever pushed in, load the terminal into the proper nest opening marked with the wire gauge on the hand tool. See Figure 2.
4. Next release the wire stop lever, allowing the wire stop to return to the crimping position.
5. Insert the properly stripped wire through the terminal and against the wire stop. See Figure 3.

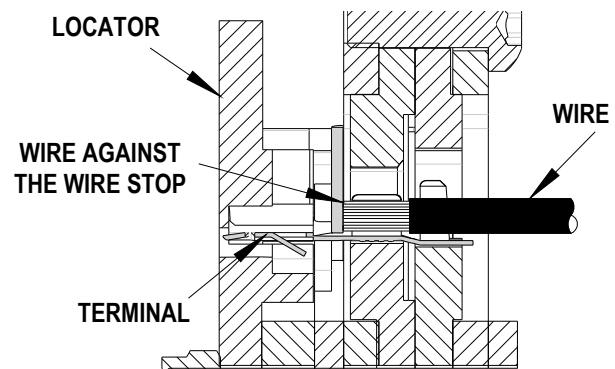
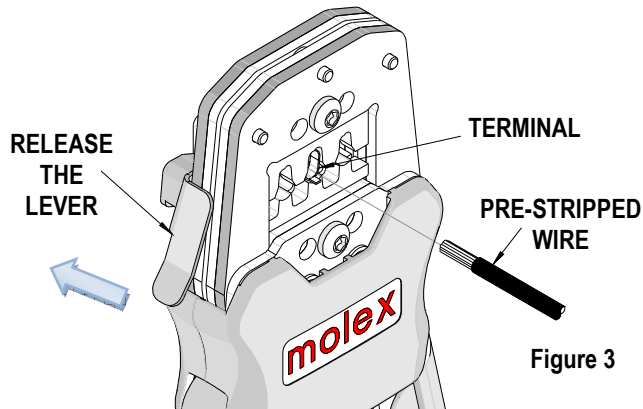
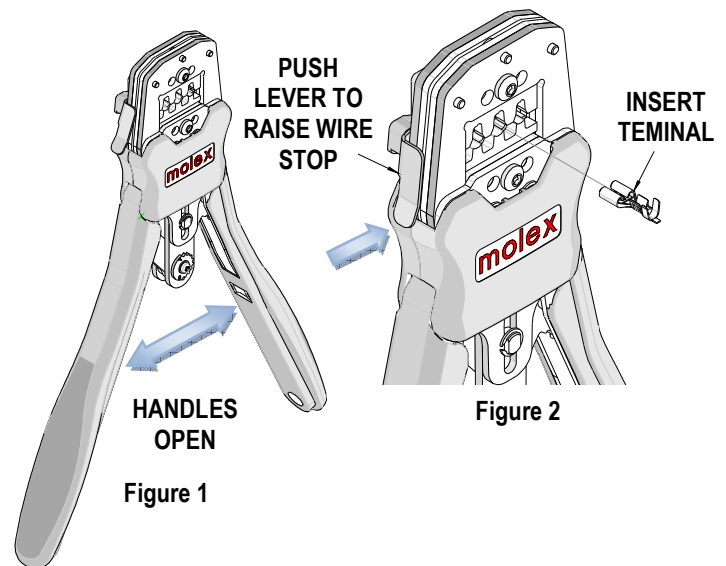

6. Crimp the terminal by squeezing the tool handles until the ratchet mechanism cycle has been completed. Release the handles to open the jaws. See Figure 4.

Note: The tamper proof ratchet action will not release the tool until it has been fully closed.

7. Push the wire stop lever in to raise the wire stop up and remove the crimped terminal from the locator by lifting up and then pulling the wire out.
8. Visually inspect the crimped terminal for proper crimp location.

Locator Replacement

See the parts list on the last page of this document for the proper locator order number. Follow the steps below to replace the locator.

1. Open the crimp hand tool and turn the tool upside down on the back side.
2. Remove the tightening lock nut.

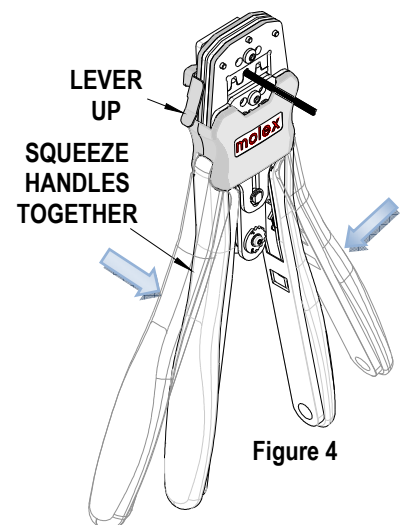

3. Remove the locator assembly from the frame head.
4. To reinstall the new locator, make sure the hand tool is in the open position.
5. Replace the locator assembly into the frame head.
6. Reinstall the tightening lock nut.

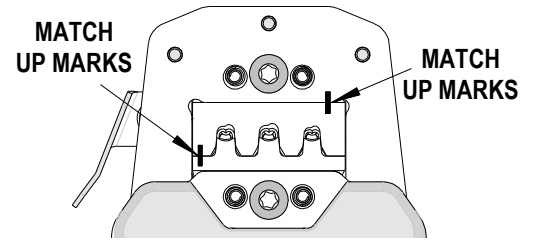

Figure 5

Remove and Install Tooling

1. Make sure the tool is in open position before remove or install tooling.
2. The locator must be removed before remove or install tooling.
3. Remove the M3 screw which is holding the upper tooling.
4. Remove or install upper tooling through the back side of the tool frame.
5. Install the M3 screw. Make sure the small markings on the front of the hand tool frame match up. See Figure 5.
6. Follow step 3 to 5 for the lower tooling except through the front side of the tool frame and install the M3 screw. Be sure the small markings on the lower tooling line up with upper tooling.
7. Slowly close the tool handles to align upper and lower tooling together. Tighten the M3 screws and continue squeezing the tool handles until the hand tool swings open.
8. Reinstall the locator by following the Instructions in the locator replacement section.

LUBRICATION
POINTS
(BOTH SIDES)
LIGHT OIL
(EVERY 3 MONTHS
OR 1,000 CRIMPS)

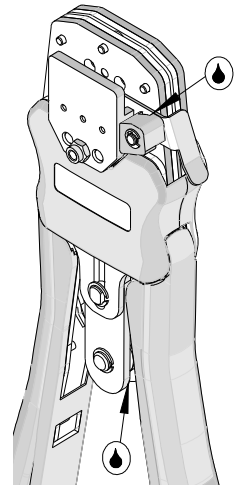

Figure 6

Maintenance

It is recommended that each operator of the tool be made aware of, and responsible for, the following maintenance steps: See Figure 6.

1. Un-snap the 2 Snap-On plastic covers front and back.
2. Remove dust, moisture, and other contaminants with a clean brush, or soft, lint free cloth.
3. Do not use any abrasive materials that could damage the tool.
4. Make certain all pins; pivot points and bearing surfaces are protected with a thin coat of high quality machine oil. Do not oil excessively. The tool was engineered for durability but like any other equipment it needs cleaning and lubrication for a maximum service life of trouble free crimping. Light oil (such as 30 weight automotive oil) used at the oil points, every 1,000 crimps or 3 months, will significantly enhance the tool life.
5. Wipe excess oil from hand tool, particularly from crimping area. Oil transferred from the crimping area onto certain terminations may affect the electrical characteristics of an application.
6. When tool is not in use, keep the handles closed to prevent objects from becoming lodged in the crimping dies, and store the tool in a clean, dry area.

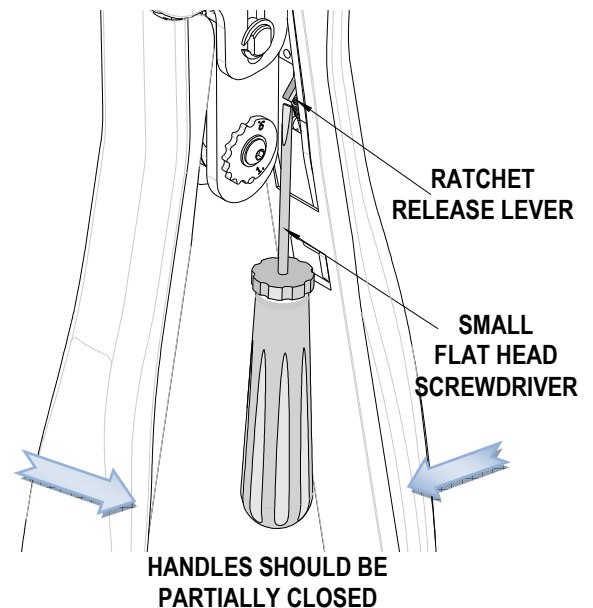

Figure 7

Miscrimps or Jams

Should this tool ever become stuck or jammed in a partially closed position, **Do Not force the handles open or closed**. The tool will open easily by using a small flat screwdriver pressing up on the ratchet release lever in the movable handle. The handle should be partially closed.

See Figure 7.

How to Adjust Tool Preload

See Figure 8

This hand tool is factory preset to 210 N (47 LBS) preload. It may be necessary over the life of the tool to adjust tool handle preload force. Listed below are the steps required to adjust the crimping force of the hand tool to obtain proper crimp conditions:

1. Open the tool by squeezing the handles together until the ratchet mechanism release, the hand tool handles will spring open.
2. Remove the M3 screw and the M3 washer.
3. Lift the setting wheel off the axle. Use a small flat head screwdriver to turn the eccentric axle counter-clockwise (CCW) to increase handle force.
4. To decrease handle force, turn the eccentric axle clockwise (CW).
5. Line up the setting wheel matching the flat side with the flat edge of the axle so the wheel notch will drop onto the roll pin. The numbers will display higher.
6. Re-install the M3 washer and M3 screw.
7. Re-crimp a new sample and check the crimp specifications or conduct a pull test after tool handle preload force is adjusted.

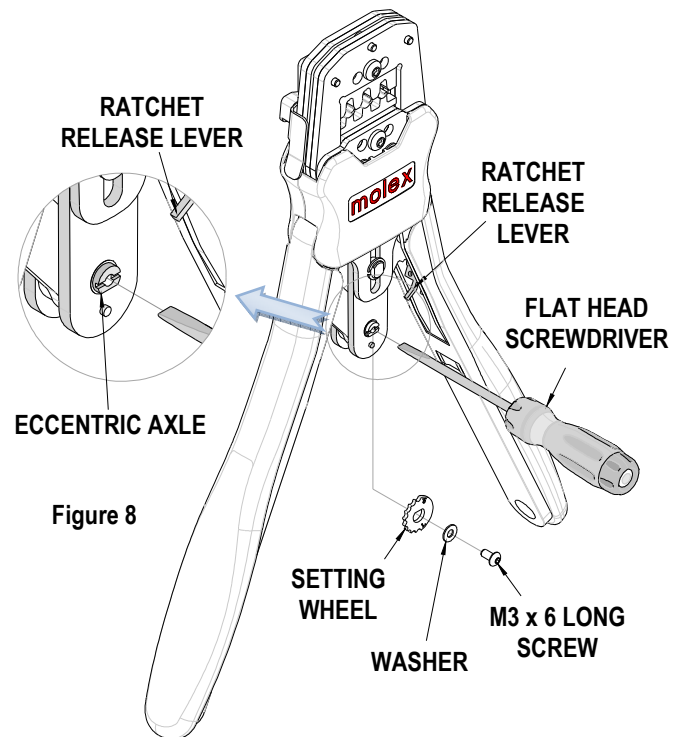

Figure 8

Warranty

This tool is for electrical terminal crimping purposes only. This tool is made of the best quality materials. All vital components are long life tested. All tools are warranted to be free of manufacturing defects for a period of 30 days. Should such a defect occur, we will repair or exchange the tool free of charge. This repair or exchange will not be applicable to altered, misused, or damaged tools. This tool is designed for hand use only. Any clamping, fixturing, or use of handle extensions voids this warranty.

CAUTION: Molex crimp specifications are valid only when used with Molex terminals and tooling.

CAUTIONS:

1. Manually powered hand tools are intended for low volume or field repair. This tool is **NOT** intended for production use. Repetitive use of this tool should be avoided.
2. Insulated rubber handles are not protection against electrical shock.
3. Wear eye protection at all times.
4. Use only the Molex terminals specified for crimping with this tool.

Certification

Molex does not certify or re-certify hand tools but rather supplies the following guidelines for customers to re-certify hand tools.

- % This tool is qualified to pull force only. See the Molex web site for the Quality Crimp Handbook for more information on pull testing.
- % If the tool does not meet minimum pull force values, handle preload should be increased and the pull test rerun, (See How to Adjust Preload).
- % When the hand tool is no longer capable of achieving minimum pull force, it should be taken out of service and replaced.

PARTS LIST

Item Number	Order Number	Description	Quantity
REF	63827-1200	Hand Crimp Tool	Figure 9
1	63827-1275	Locator Assembly	1
2	63810-0106	Spring, Ratchet	1

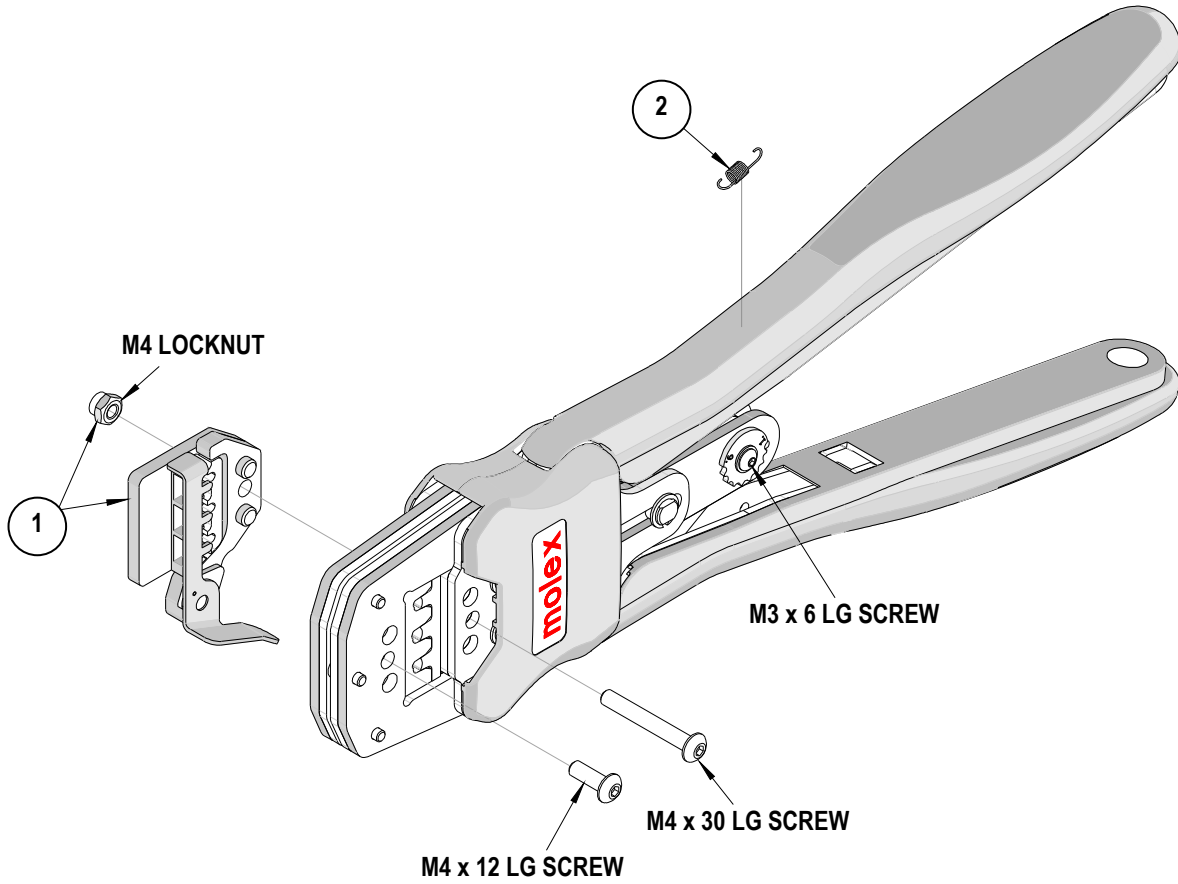

Figure 9

Visit our Web site at <http://www.molex.com>