

LOC	DIST	REVISIONS			
A1	-	DESCRIPTION	DATE	DWN	APVD
PROJEKT NR.: EGLPC00034		SEE SHEET 1	-	-	-

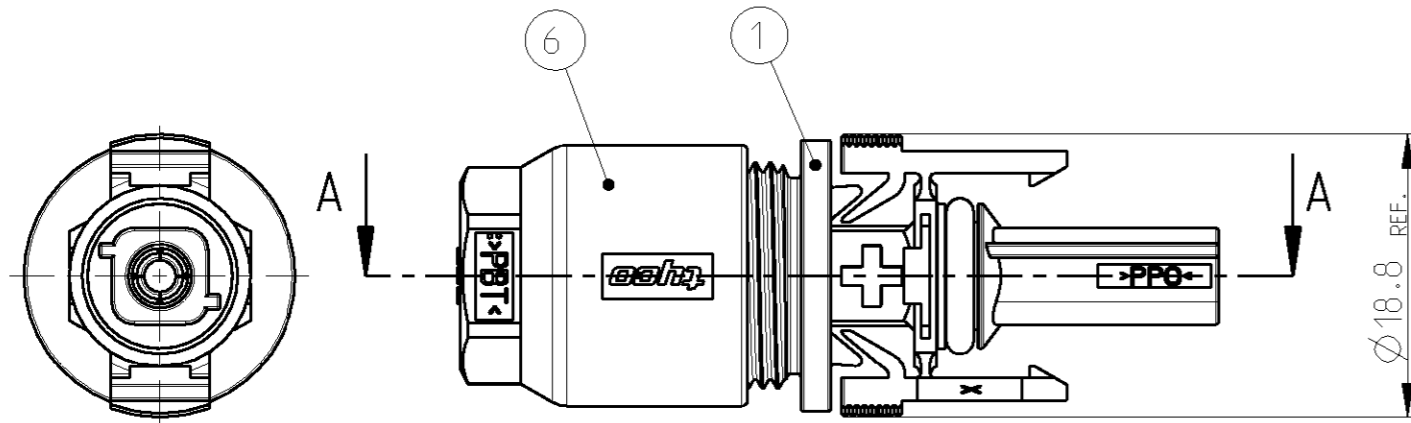

SECTION A-A  
SCHNITT A-A

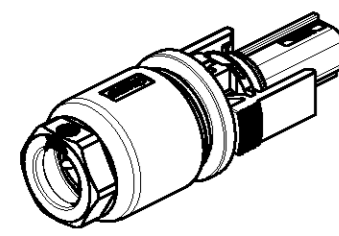

SCALE 1:1 / M 1:1

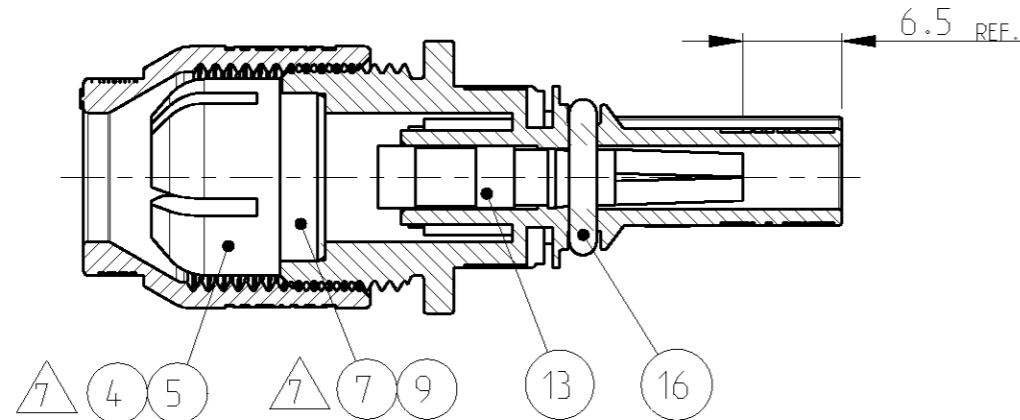

4- -8 AS SHOWN  
4- -8 WIE GEZEICHNET

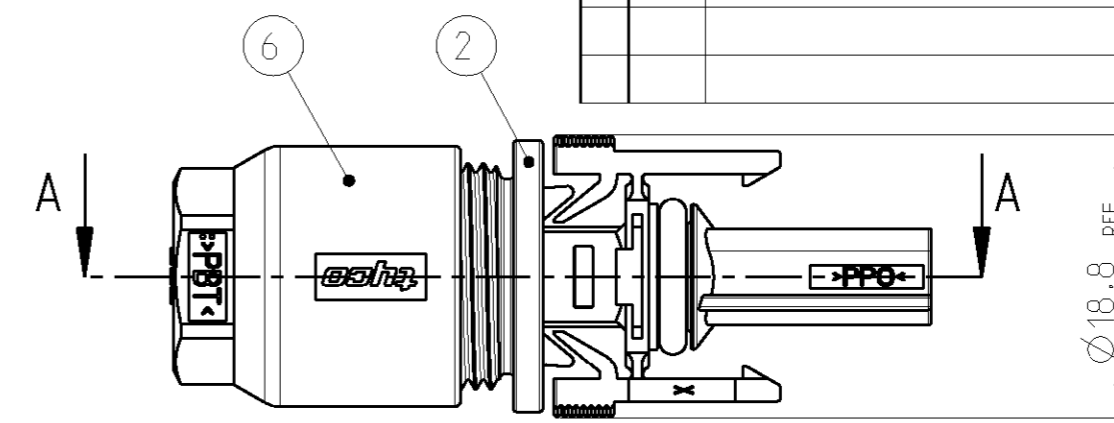
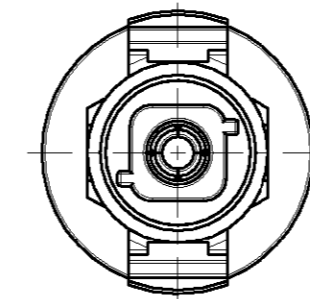

SECTION A-A  
SCHNITT A-A

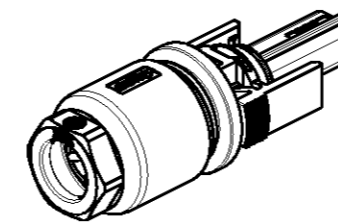

SCALE 1:1 / M 1:1

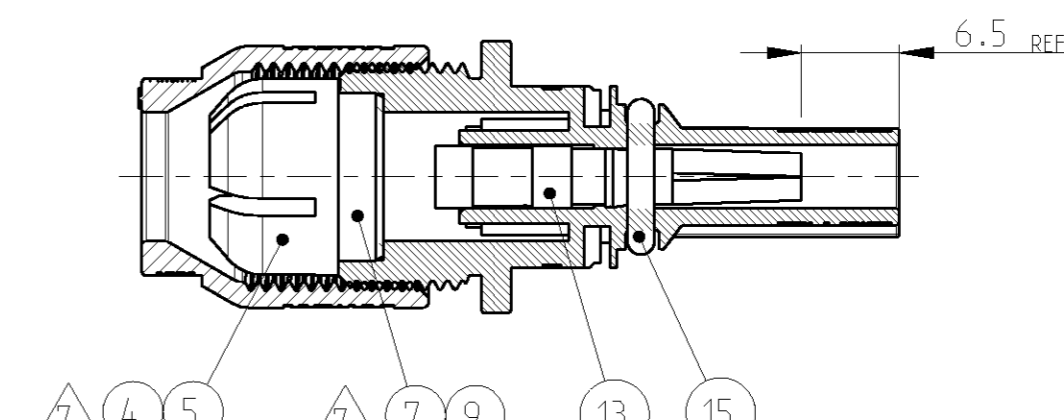

4- -9 AS SHOWN  
4- -9 WIE GEZEICHNET

- 8 **PACKAGING INSTRUCTION:** NOT ASSEMBLED SOCKET CONTACT ASSY HVT, SEAL AND CABLE SCREW JOINT PACKAGED IN MINIGRIP BAG ( ITEM NO. 22 ). LABEL ( ITEM NO. 19 ) ENCLOSE LOOSELY.
- 9 **PACKAGING UNIT:** 100 SINGLE PACKAGED PHOTOVOLTAIK CONNECTORS ACCORDING TO 8 PACKAGED IN CORRUGATED SHIPPING BOX. PUT INSIDE ON TOP CORRUGATED SHIPPING BOX INSTRUCTION SHEET ( ITEM NO. 23 ).
- 10 **MINIMUM ORDER QUANTITY:** 100 PIECES
- 11 **ASSEMBLY INSTRUCTION:**
  - 1.) CRIMP CONTACT WITH HANDTOOL PN 1-1105851-8 PER AMP-SPEC. 114-74013
  - 2.) INSERT SEAL IN CONNECTOR UP TO DOG
  - 3.) PUSH CABLE SCREW JOINT AND PINCH RING ON WIRE
  - 4.) INSERT CONTACT WITH WIRE IN SOCKET HOUSING
  - 5.) PUSH PINCH RING ON SEAL
  - 6.) SCREW CABLE SCREW JOINT ON HOUSING

12 **TIGHTENING TORQUE** SEE APPLICATION SPEC. 114-18488

8 **VERPACKUNGSANWEISUNG:** NICHT MONTIERTER BUCHSENKONTAKT ASSY HVT, DICHTUNG UND KABELVERSCHRAUBUNG IM MINIGRIP-BEUTEL ( POS. 22 ) VERPACKT. ETIKETT ( POS. 19 ) LOSE BEIGELEGT.

9 **VERPACKUNGSEINHEIT:** 100 EINZEL VERPACKTE PHOTOVOLTAIK STECKVERBINDER GEMÄSS 8 IM VERSANDKARTON VERPACKT. VERSANDKARTON VERARBEITUNGSANWEISUNG ( POS. 23 ) OBENAUF BEIGELEGT.

10 **MINDESTBESTELLMENGE:** 100 STÜCK

11 **MONTAGEANWEISUNG:**

- 1.) KONTAKT NACH AMP-SPEZ. 114-74013 MIT HANDZANGE PN 1-1105851-8 ANCRIMPEN
- 2.) DICHTUNG IN STECKVERBINDER BIS ANSCHLAG EINDRÜCKEN
- 3.) KABELVERSCHRAUBUNG UND KLEMMKORB AUF LEITUNG AUFSCHEIBEN
- 4.) KONTAKT MIT LEITUNG IN BUCHSENGEHÄUSE EINDRÜCKEN
- 5.) KLEMMKORB AUF DICHTUNG AUFSCHEIBEN
- 6.) KABELVERSCHRAUBUNG AUF GEHÄUSE AUFSCHRAUBEN

12 **ANZUGSDREHMOMENT** SIEHE VERARBEITUNGSSPEZIFIKATION 114-18488

<small>THIS DRAWING IS A CONTROLLED DOCUMENT FOR TYCO ELECTRONICS CORPORATION IT IS SUBJECT TO CHANGE AND THE CONTROLLING ENGINEERING ORGANIZATION SHOULD BE CONTACTED FOR THE LATEST REVISION.          DIESES ZEICHNUNGSÄRBEIT WIRD DURCH AMP INCORPORATED KONTROLLIERT. ÄNDERUNGEN, DIE SICH TECHNISCHEN FORTSCHRITT DÜRNEN, SIND VORBEHALTEN. DEN JEWELN LETZTGEWISSEN ÄNDERUNGSSTAND ERFAHREN SIE AUF ANFRAGE.</small>		DWN E.WERNER 05-SEP-00 CHK H.SCHERER 05-SEP-00 APVD G.FELDMAYER 05-SEP-00		<b>tyco</b> Electronics tyco Electronics AMP GmbH D - 64625 Bensheim	
DIMENSIONS: MASSEINHEITEN: (MM)		TOLERANCES UNLESS OTHERWISE SPECIFIED: ALLGEMEINTOLERANZEN		NAME PHOTOVOLTAIK CONNECTOR 1 POS. PHOTOVOLTAIK STECKVERBINDER 1 POL.	
		0 PLC ±0.2 1 PLC ± 2 PLC ± 3 PLC ± 4 PLC ± ANGLES/WINKEL ± FINISH/OBERFLÄCHE/FARBE -		PRODUCT SPEC PRODUKTSPEZ. 108-18701 APPLICATION SPEC VERARBEITUNGSSPEZ. 114-18488	
MATERIAL -		WEIGHT GEWICHT -		SIZE A2 CAGE CODE 00779 DRAWING NO. ZEICHNUNGS-NR. 1394462 RESTRICTED TO NUR FÜR -	
CUSTOMER DRAWING		/KUNDENZEICHNUNG		SCALE MASSSTAB 2:1 SHEET BLATT 2 OF VON 2 REV J1	

LOC	DIST	REVISIONS					
P	LTR	DESCRIPTION	DATE	DWN	APVD		
A1	-	PROJEKT NR.: EGLPC00034	F1	-3, -4, 4- -8 AND 4- -9 SEAL ø7 IN PLACE OF SEAL ø8	17-OCT-02	EW	GF
			G1	ITEM NO. 4.5.15.23 ADDED. ITEM NO.16 SILICONE WAS VMQ	11-AUG-03	EW	GF
			H1	ITEM NO. 1 AND 2 SOCKET HOUSINGS MODIFIED	14NOV2003	AW	GF
			J1	DASH NO. 5- -5 UP TO 5- -8 ADDED	30-AUG-04	EW	GF
				NOTE 1 AND 2 COMPLETED			

- 1 **PACKAGING INSTRUCTION:** 100 PIECES OF EACH PART PACKAGED IN MINIGRIP BAG ( ITEM NO. 20 ). MINIGRIP BAG ( ITEM NO. 20 ) PROVIDED WITH LABEL AND LABEL MARKED WITH PART NUMBER, QUANTITY AND DESCRIPTION.
- 2 **PACKAGING INSTRUCTION:** 100 PIECES OF EACH PART PACKAGED IN PLASTIC BAG ( ITEM NO. 21 ). PLASTIC BAG ( ITEM NO. 21 ) PROVIDED WITH LABEL AND LABEL MARKED WITH PART NUMBER, QUANTITY AND DESCRIPTION.
- 3 **PACKAGING UNIT:** ALL COMPONENTS OF EACH DASH-NUMBER PACKAGED ACCORDING TO 1 OR 2 PACKAGED IN CORRUGATED SHIPPING BOX. PUT INSIDE ON TOP CORRUGATED SHIPPING BOX INSTRUCTION SHEET ( ITEM NO. 23 ).
- 4 **USE ONLY SOLAR CABLE TYPE:** OKONITE USE-2
- 5 **MINIGRIP BAGS ( ITEM NO. 20 AND 22 ), PLASTIC BAG ( ITEM NO. 21 ), LABEL ( ITEM NO. 19 ) AND INSTRUCTION SHEET ( ITEM NO. 23 ) NOT SHOWN**
- 6 **O-RINGS ( ITEM NO. 15 AND 16 ) ASSEMBLED ON SOCKET HOUSING ( ITEM NO. 1 OR 2 )**
- 7 **SEAL ( ITEM NO. 7 TO 10 ) AND PINCH RING ( ITEM NO. 4 AND 5 ) ACCORDING TO CABLE DIAMETER. SEE APPLICATION SPECIFICATION 114-18488.**
- 1 **VERPACKUNGSANWEISUNG:** 100 STÜCK VON JEDEM TEIL IM MINIGRIP-BEUTEL ( POS. 20 ) VERPACKT. MINIGRIP-BEUTEL ( POS. 20 ) MIT ETIKETT VERSEHEN UND ETIKETT MIT TEILNUMMER, STÜCKZAHL UND BEZEICHNUNG BESCHRIFTET.
- 2 **VERPACKUNGSANWEISUNG:** 100 STÜCK VON JEDEM TEIL IM KUNSTSTOFF-BEUTEL ( POS. 21 ) VERPACKT. KUNSTSTOFF-BEUTEL ( POS. 21 ) MIT ETIKETT VERSEHEN UND ETIKETT MIT TEILNUMMER, STÜCKZAHL UND BEZEICHNUNG BESCHRIFTET.
- 3 **VERPACKUNGSEINHEIT:** ALLE KOMPONENTEN EINER STRICHVARIANTE VERPACKT GEMÄSS 1 BZW. 2 IN VERSANDKARTON VERPACKT. VERSANDKARTON VERARBEITUNGSANWEISUNG ( POS. 23 ) OBENAUF BEIGELEGT.

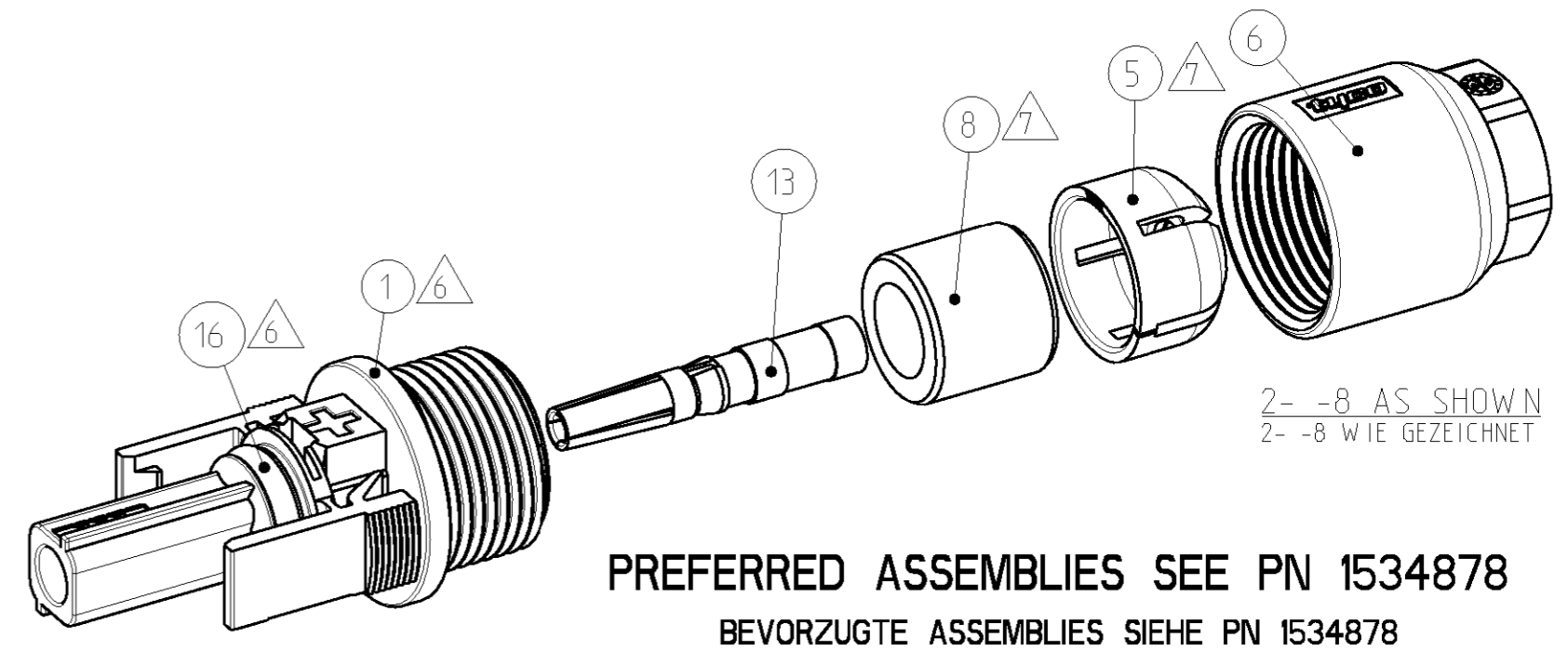

ITEM-NO. POS.	DESCRIPTION	QUANTITY	STÜCK
5-1394462-8	OBSOLETE	1/100	1/100
5-1394462-7	OBSOLETE	1/100	1/100
5-1394462-6	OBSOLETE	1/100	1/100
5-1394462-5	OBSOLETE	1/100	1/100
5-1394462-4	OBSOLETE	1/100	1/100
5-1394462-3	OBSOLETE	1/100	1/100
5-1394462-2	OBSOLETE	1/100	1/100
5-1394462-1	OBSOLETE	1/100	1/100
4-1394462-9	OBSOLETE	1/100	1/100
4-1394462-8	OBSOLETE	1/100	1/100
4-1394462-7	OBSOLETE	1/100	1/100
4-1394462-6	OBSOLETE	1/100	1/100
4-1394462-5	OBSOLETE	1/100	1/100
4-1394462-4	OBSOLETE	1/100	1/100
4-1394462-3	OBSOLETE	1/100	1/100
4-1394462-2	OBSOLETE	1/100	1/100
4-1394462-1	OBSOLETE	1/100	1/100
3-1394462-9	OBSOLETE	1/100	1/100
3-1394462-8	OBSOLETE	1/100	1/100
3-1394462-7	OBSOLETE	1/100	1/100
3-1394462-6	OBSOLETE	1/100	1/100
3-1394462-5	OBSOLETE	1/100	1/100
3-1394462-4	OBSOLETE	1/100	1/100
3-1394462-3	OBSOLETE	1/100	1/100
3-1394462-2	OBSOLETE	1/100	1/100
3-1394462-1	OBSOLETE	1/100	1/100
2-1394462-9	OBSOLETE	1/100	1/100
2-1394462-8	OBSOLETE	1/100	1/100
2-1394462-7	OBSOLETE	1/100	1/100
2-1394462-6	OBSOLETE	1/100	1/100
2-1394462-5	OBSOLETE	1/100	1/100
2-1394462-4	OBSOLETE	1/100	1/100
2-1394462-3	OBSOLETE	1/100	1/100
2-1394462-2	OBSOLETE	1/100	1/100
2-1394462-1	OBSOLETE	1/100	1/100
1-1394462-9	OBSOLETE	1/100	1/100
1-1394462-8	OBSOLETE	1/100	1/100
1-1394462-7	OBSOLETE	1/100	1/100
1-1394462-6	OBSOLETE	1/100	1/100
1-1394462-5	OBSOLETE	1/100	1/100
1-1394462-4	OBSOLETE	1/100	1/100
1-1394462-3	OBSOLETE	1/100	1/100
1-1394462-2	OBSOLETE	1/100	1/100
1-1394462-1	OBSOLETE	1/100	1/100
1394462-9	OBSOLETE	1/100	1/100
1394462-8	OBSOLETE	1/100	1/100
1394462-7	OBSOLETE	1/100	1/100
1394462-6	OBSOLETE	1/100	1/100
1394462-5	OBSOLETE	1/100	1/100
1394462-4	OBSOLETE	1/100	1/100
1394462-3	OBSOLETE	1/100	1/100
1394462-2	OBSOLETE	1/100	1/100
1394462-1	OBSOLETE	1/100	1/100
23	INSTRUCTION SHEET	1	1
22	MINIGRIP BAG	1	1
21	PLASTIC BAG	1	1
20	MINIGRIP BAG	7	7
19	LABEL	1	1
18	ETIKETT	1	1
17	ETIKETT	1	1
16	O-RING 6.7x1.8	1	1
15	O-RING 6.7x1.8	1	1
14	SOCKET CONTACT ASSY HVT. 6 mm <sup>2</sup> / AWG 10	1	1
13	SOCKET CONTACT ASSY HVT. 4 mm <sup>2</sup> / AWG 12	1	1
12	SOCKET CONTACT ASSY HVT. 2.5 mm <sup>2</sup>	1	1
11	SOCKET CONTACT ASSY HVT. 1.5 mm <sup>2</sup>	1	1
10	SEAL Ø5	1	1
9	SEAL Ø6	1	1
8	SEAL Ø7	1	1
7	SEAL Ø8	1	1
6	CABLE SCREW JOINT	1	1
5	PINCH RING	1	1
4	PINCH RING	1	1
3	SOCKET HOUSING WITHOUT CODING	1	1
2	SOCKET HOUSING MINUS	1	1
1	SOCKET HOUSING PLUS	1	1

**TYCO  
ORDER-NO.  
BESTELL-NR.**

- 4 **NUR SOLARKABEL TYP: OKONITE USE-2 VERWENDEN**
- 5 **MINIGRIP-BEUTEL ( POS. 20 UND 22 ), KUNSTSTOFF-BEUTEL ( POS. 21 ), ETIKETT ( POS. 19 ) UND VERARBEITUNGSANWEISUNG ( POS. 23 ) NICHT DARGESTELLT**
- 6 **O-RINGE ( POS. 15 UND 16 ) AUF BUCHSENSTECKER ( POS. 1 ODER 2 ) MONTIERT**
- 7 **DICHTUNG ( POS. 7 BIS 10 ) UND KLEMMKORB ( POS. 4 UND 5 ) ENTSPRECHEND DEM LEITUNGSDURCHMESSER. SIEHE VERARBEITUNGSSPEZIFIKATION 114-18488.**

THIS DRAWING IS A CONTROLLED DOCUMENT FOR TYCO ELECTRONICS CORPORATION IT IS SUBJECT TO CHANGE AND THE CONTROLLING ENGINEERING ORGANIZATION SHOULD BE CONTACTED FOR THE LATEST REVISION. DIESES ZEICHNUNGSORGANISIMENT WIRD DURCH AMP INCORPORATED KONTROLLIERT. ANÄNDERUNGEN, DIE SICH TECHNISCHEN FORTSCHRITT BEZIEHEN, SIND VORBEHALTEN. DEN ÄNDERUNGSSTAND ERFAHREN SIE AUF ANFRAGE.		DWN E.WERNER 25-JAN-02 CHK H.SCHERER 25-JAN-02 APVD G.FELDMEIER 25-JAN-02	tyco Electronics tyco Electronics AMP GmbH D - 64625 Bensheim
DIMENSIONS: MASSEINHEITEN: [mm]	TOLERANCES UNLESS OTHERWISE SPECIFIED: ALLGEMEINTOLERANZEN	NAME PHOTOVOLTAIK CONNECTOR 1 POS. PHOTOVOLTAIK STECKVERBINDER 1 POL.	SIZE A2
MATERIAL -	FINISH/OBERFLÄCHE/FARBE -	APPLICATION SPEC 108-18701 VERARBEITUNGSSPEZ. 114-18488	CAGE CODE 00779
CUSTOMER DRAWING		SCALE 1:1	SHEET 1 OF 2
WEIGHT -		DRAWING NO. 1394462	RESTRICTED TO NUR FÜR -
REV J1		REV J1	