

THIS DRAWING IS UNPUBLISHED. RELEASED FOR PUBLICATION
 © COPYRIGHT BY TYCO ELECTRONICS CORPORATION. ALL INTERNATIONAL RIGHTS RESERVED.

LOC	DIST	REVISIONS			
P	LTR	DESCRIPTION	DATE	DWN	APVD
FT	0				
	J	REVISED PER ECO-10-021995	12JAN11	HMR	MG

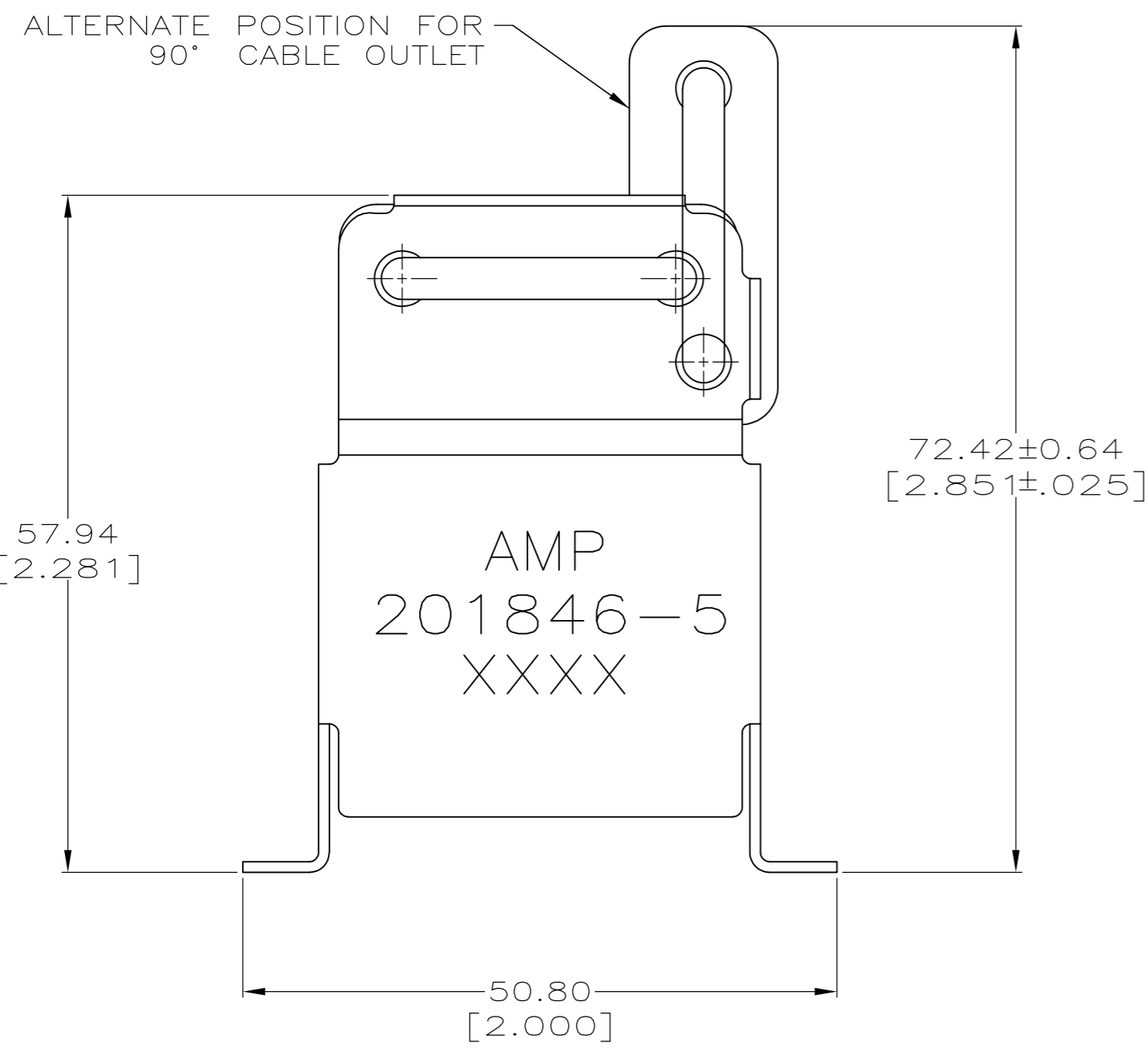
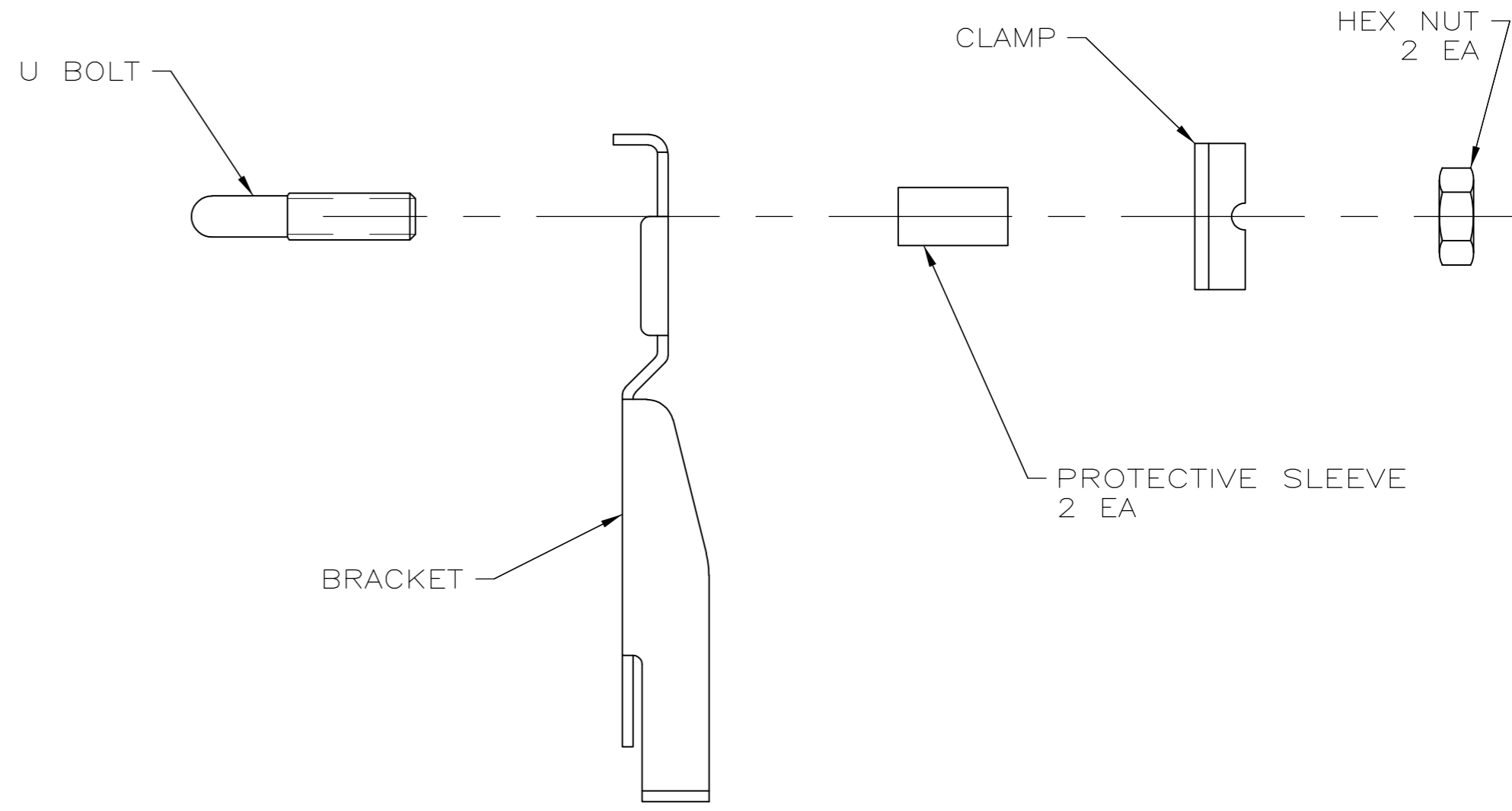
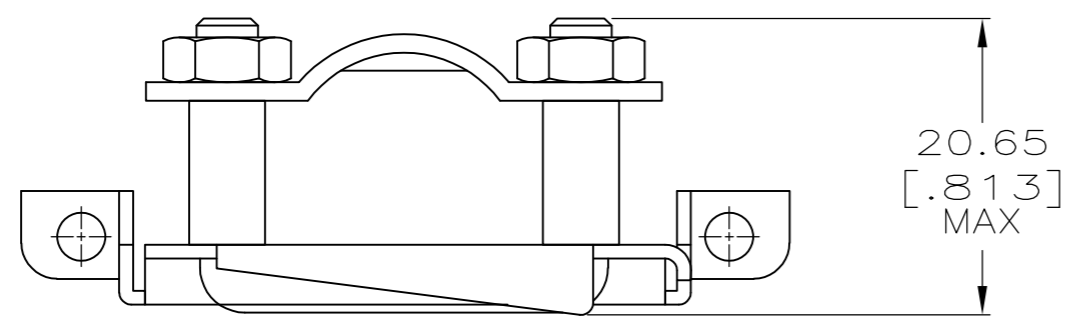

ASSEMBLED VIEW

- 1 BRACKET, CLAMP & HEX NUTS: CARBON STEEL.
U BOLT: STAINLESS STEEL.
PROTECTIVE SLEEVES: POLYVINYL CHLORIDE.
- 2 BRACKET & CLAMP: 5.08um[.000200] MIN NICKEL.
U BOLT: PASSIVATED.

	201846-5
SUPERSEDED BY 201846-5	201846-1
	PART NUMBER

THIS DRAWING IS A CONTROLLED DOCUMENT.		DWN C.REIFSNYDER 03 OCT 95	Tyco Electronics Corporation Harrisburg, PA 17105-3608	
DIMENSIONS: mm [INCHES]		CHK R.STONE 10 OCT 95	NAME CLAMP KIT, UNASSEMBLED, 34 PLACE, STRAIN RELIEF, M SERIES	
TOLERANCES UNLESS OTHERWISE SPECIFIED:		APVD G.A.STEINHAUER 05 NOV 95	SIZE A2	CAGE CODE 00779
0 PLC ± - 1 PLC ± - 2 PLC ± 0.38[.015] 3 PLC ± - 4 PLC ± - ANGLES ± -		PRODUCT SPEC -	DRAWING NO C=201846	RESTRICTED TO -
MATERIAL -	FINISH -	WEIGHT -	SCALE 2:1	SHEET 1 of 1
CUSTOMER DRAWING			REV J	