

Enclosures can be Factory Modified (Milling, Drilling, Printing etc.)
Contact Factory mjm@hammondmfg.com for quotes
Solid models of this enclosure available in STEP or IGES.
(Part number and text placement/orientation on our products are subject to change, we do not recommend using them as a locating reference for modification purposes)

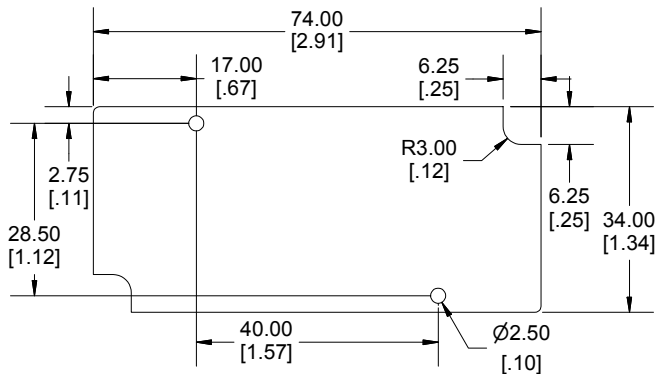
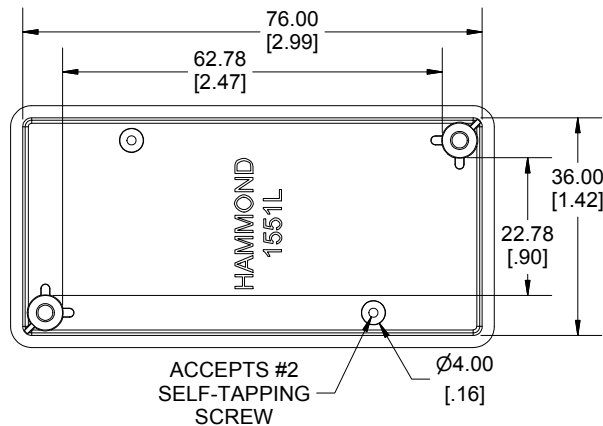

Dimensions:
mm
[inches]

NOTE

Purchased assembly includes box, lid, 2 cover screws.
Enclosure molded from general purpose ABS Plastic.
Other materials / colours available consult factory.

Recommended Torque : (35-43) Ozf.in / (25-30) cN.m

PART NUMBERS

| 1551LFL Enclosure | | |
|--|--|-----------------------|
| Black Enclosure - Ral 9011 - UL94 - HB | | 1551LFLBK |
| Gray Enclosure - RAL 7035 - UL94 - HB | | 1551LFLGY |
| Tranlucent Blue - UL94 - HB | | 1551LFLTBU |
| ACCESSORIES | | |
| Black Cover Screws #4 X 1/2" Self-tapping | | 1591TS100BK (Pkg 100) |
| Plated Cover Screws #4 X 1/2" Self-tapping | | 1591TS100 (Pkg 100) |
| P.C. Board Screws | | 1551ATS50 (Pkg 50) |
| #2 x 3/16" self-tapping (4.8mm) | | 1551ATS100 (Pkg 100) |

