

LARGE INSULATION CRIMP

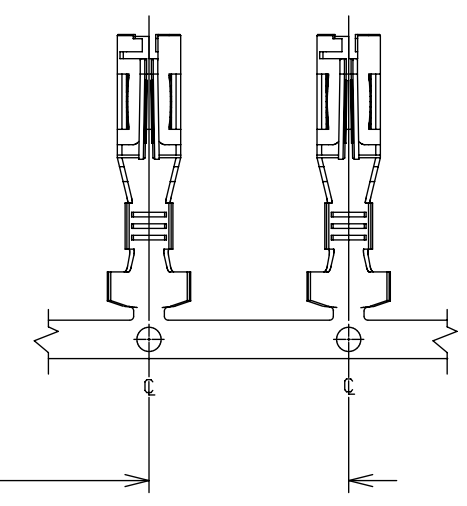

NOTES:

1. MATERIAL: .012/(0.30) THICK C26000 BRASS.
2. FINISH: HOT TIN DIP.
3. PRODUCT SPECIFICATION: PS-44441-9999.
4. PACKAGING SPECIFICATION: 433750000-PK
5. FOR USE IN 44441 SERIES HOUSINGS
6. SINGLE CRIMP TO #16 & #14 AWG WIRE WITH .060"/(1.52) MAXIMUM INSULATION THICKNESS, OR DOUBLE CRIMP TO #18 AWG WIRE WITH .032"/(0.81) MAXIMUM INSULATION THICKNESS.
7. NO PORTION OF ONE LOCK TANG BEAM SHALL TOUCH ANY PORTION OF THE OTHER LOCK TANG BEAM.
8. PARTS CONFORM TO CLASS 'B' REQUIREMENTS OF COSMETIC SPECIFICATION PS-45499-002.

THIS DRAWING CONTAINS INFORMATION THAT IS PROPRIETARY TO MOLEX ELECTRONIC TECHNOLOGIES, LLC AND SHOULD NOT BE USED WITHOUT WRITTEN PERMISSION										
SYMBOLS		DIMENSION UNITS		SCALE		CURRENT REV DESC: ADD PK SPEC				
▽ = 0	IN/MM	10:1				EC NO: 617584				
▽ = 0	GENERAL TOLERANCES (UNLESS SPECIFIED)				DRWN: JEHRISMAN		2019/04/02			
▽ = 0					CHK'D: MKIPPER		2019/06/13			
▽ = 0	4 PLACES	±		±	APPR: FSMITH		2019/06/18			
▽ = 0	3 PLACES	±		± 0.005	INITIAL REVISION:					
▽ = 0	2 PLACES	± 0.13		± 0.01	DRWN: MAB		1994/05/08			
▽ = 0	1 PLACE	± 0.25		±	APPR: RAS		1994/05/08			
▽ = 0	0 PLACES	±		±	THIRD ANGLE PROJECTION		DRAWING SERIES			
▽ = 0	ANGULAR TOL	± 0.5°			C-SIZE		43375			
▽ = 0	DRAFT WHERE APPLICABLE MUST REMAIN WITHIN DIMENSIONS				MATERIAL NUMBER		CUSTOMER		SHEET NUMBER	
						433751001		GENERAL MARKET		1 OF 1

**molex**

TERMINAL, RECEPTACLE  
.125/(3.18)X.020/.51 FLAT BLADE SYSTEM - TPA

PRODUCT CUSTOMER DRAWING

DOCUMENT NUMBER: **SD-43375-1001** | DOC TYPE: PSD | DOC PART: 001 | REVISION: F2