

REVISIONS				
P.	LTN.	DESCRIPTION	DATE	APVD.
B		REVISED PER ECO-10-012356	14DEC2010	CJV EJB
C		ECO-15-006497	13APR2016	LL SH

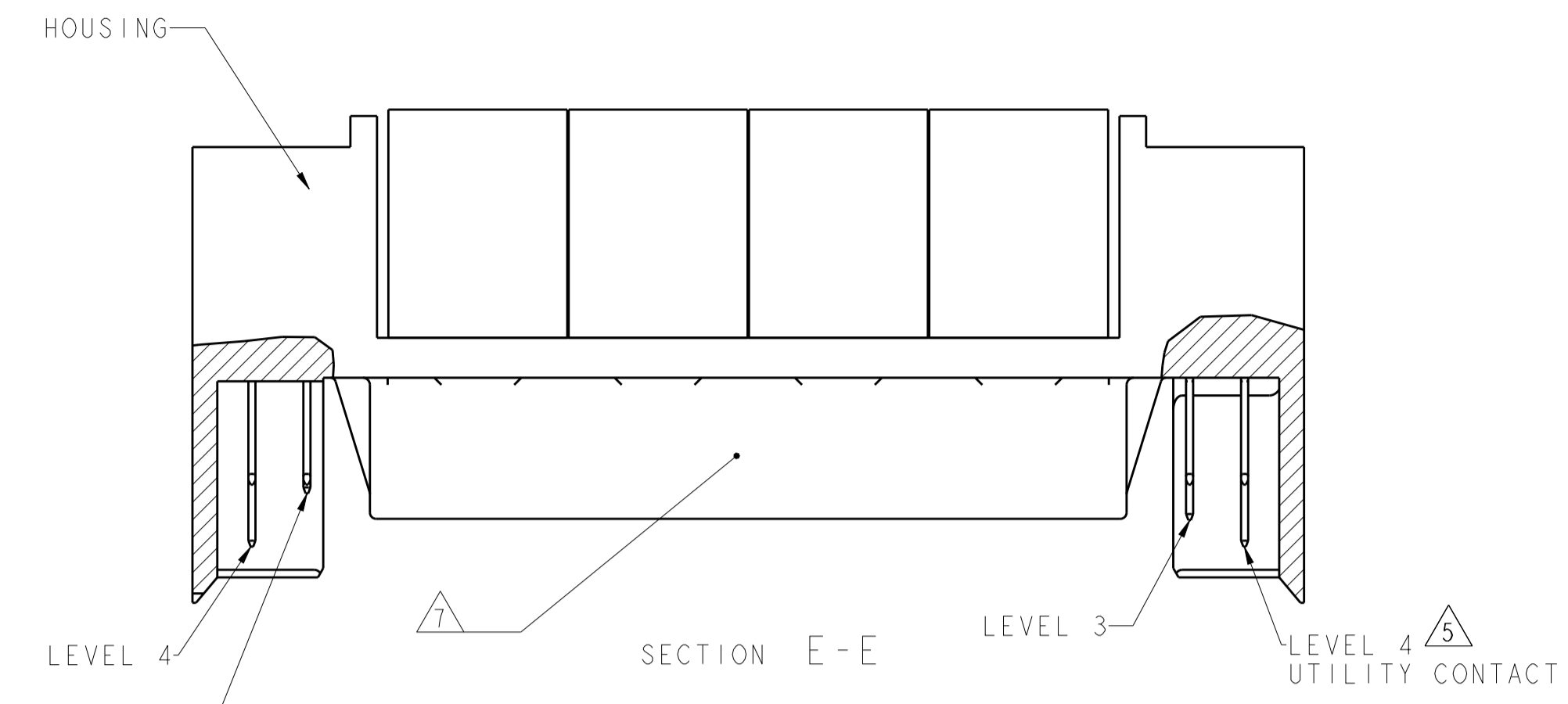

- 1 HOUSINGS: POLYESTER, UL 94V-0 RATED, NATURAL SIGNAL AND SIGNAL GROUND CONTACTS: COPPER ALLOY UTILITY CONTACTS: PHOSPHOR BRONZE
- 2 UTILITY CONTACTS: 0.76µm MIN GOLD IN CONTACT AREA, 2.54µm MIN TIN-LEAD ON PCB TAILS, OVER 1.27µm MIN NICKEL OVER ALL. SIGNAL AND SIGNAL GROUND CONTACTS: 0.76µm MIN GOLD IN CONTACT AREA, 2.54µm MIN TIN-LEAD ON PCB TAILS, OVER 1.27µm MIN NICKEL OVER ALL.
- 3. ROWS A, C, D, AND F ARE SIGNAL CONTACTS. ROWS B AND E ARE SIGNAL GROUND CONTACTS.
- 4 DIMENSIONS PER CUSTOMER BOARD LAYOUT.
- 5 SEE UTILITY CONTACT SEQUENCE TABLE FOR LOCATION AND LEVEL/LENGTH OF UTILITY CONTACTS FOR EACH PRODUCT PART NUMBER. UTILITY LEVEL 1 CAN BE USED FOR SENSING. UTILITY LEVELS 2, 3, AND 4 CAN BE USED FOR POWER, GROUND, OR ESD. SEQUENCING SHOWN IN SECTION E-E SHOWS THREE LEVELS FOR COMPARISON. UTILITY LEVEL 2 EQUALS THE SIGNAL GROUND CONTACT LEVEL. SIGNAL LEVEL IS BETWEEN UTILITY LEVELS 1 AND 2.
- 6. BLOCK DIAGRAM AND CONTACT IDENTIFICATION APPLY TO COPLANAR NON-INVERTED APPLICATION ONLY. CONTACT IDENTIFICATION REVERSES FOR INVERTED APPLICATIONS, I.E COPLANAR OR MID-BOARD INVERTED.
- 7 COMPANY LOGO IN APPROXIMATE AREA SHOWN.
- 8 OBSOLETE PART.

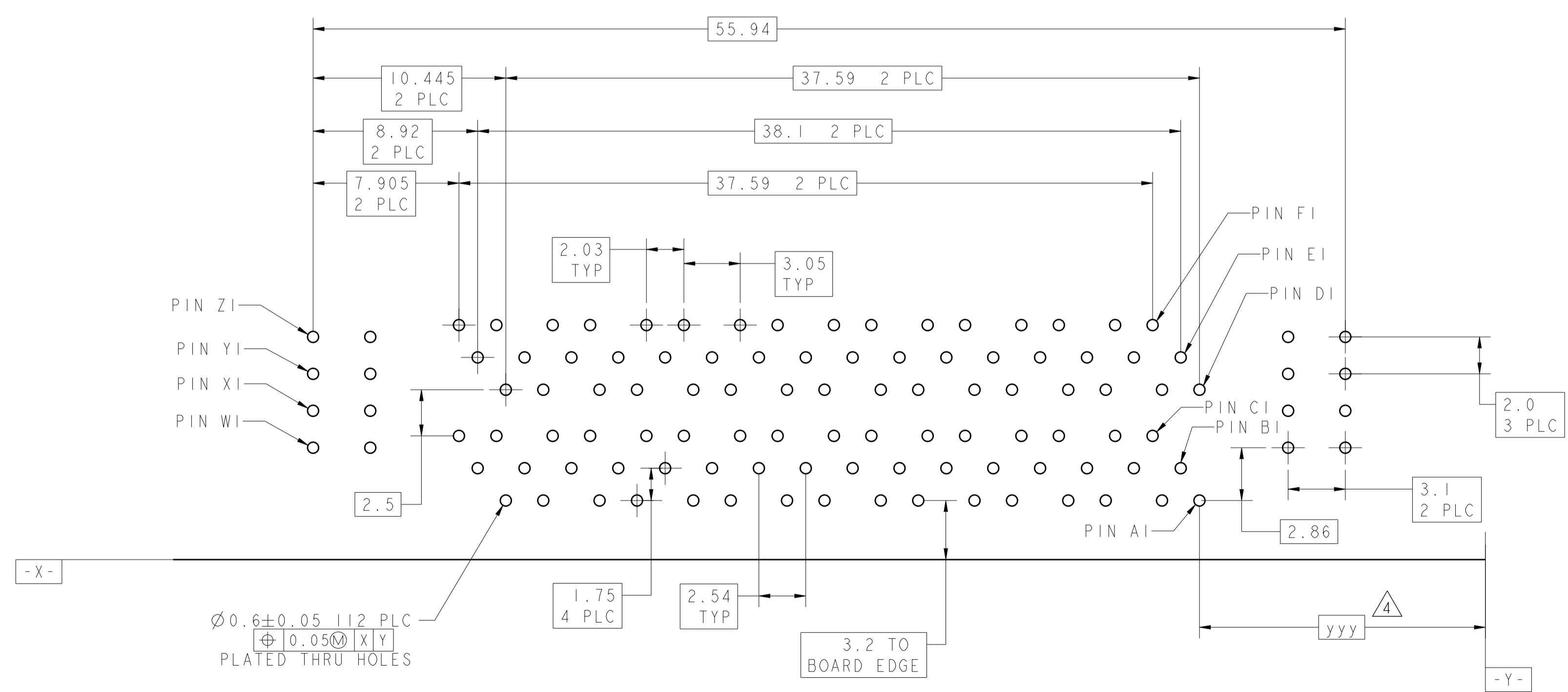
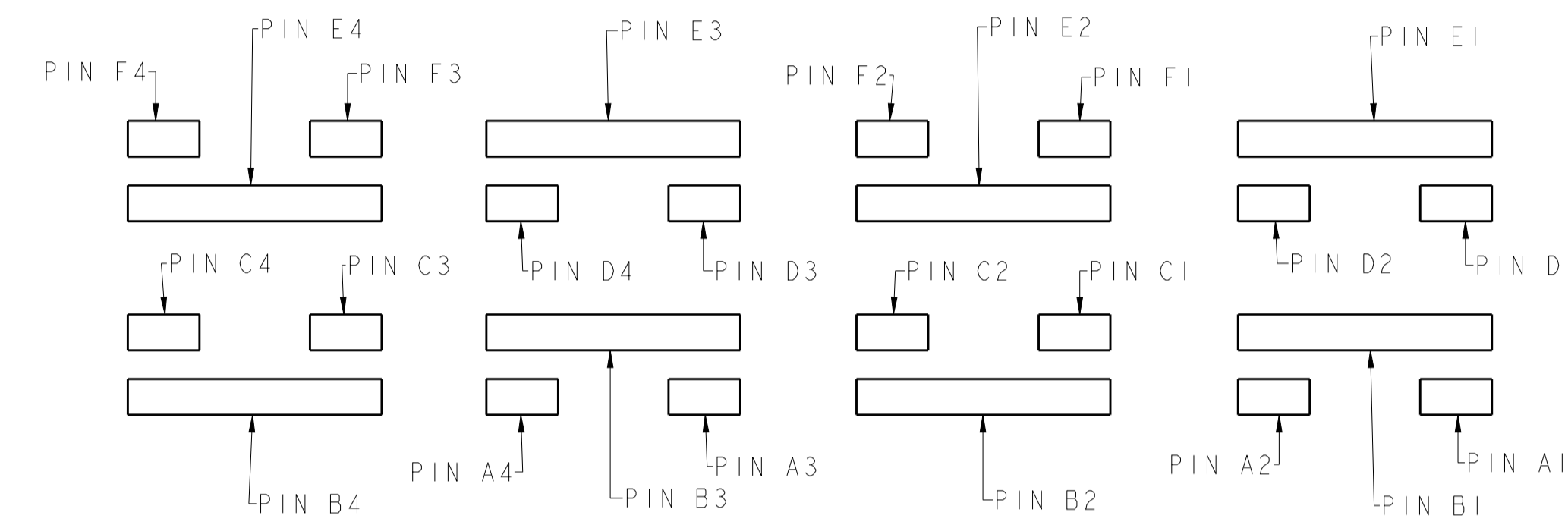
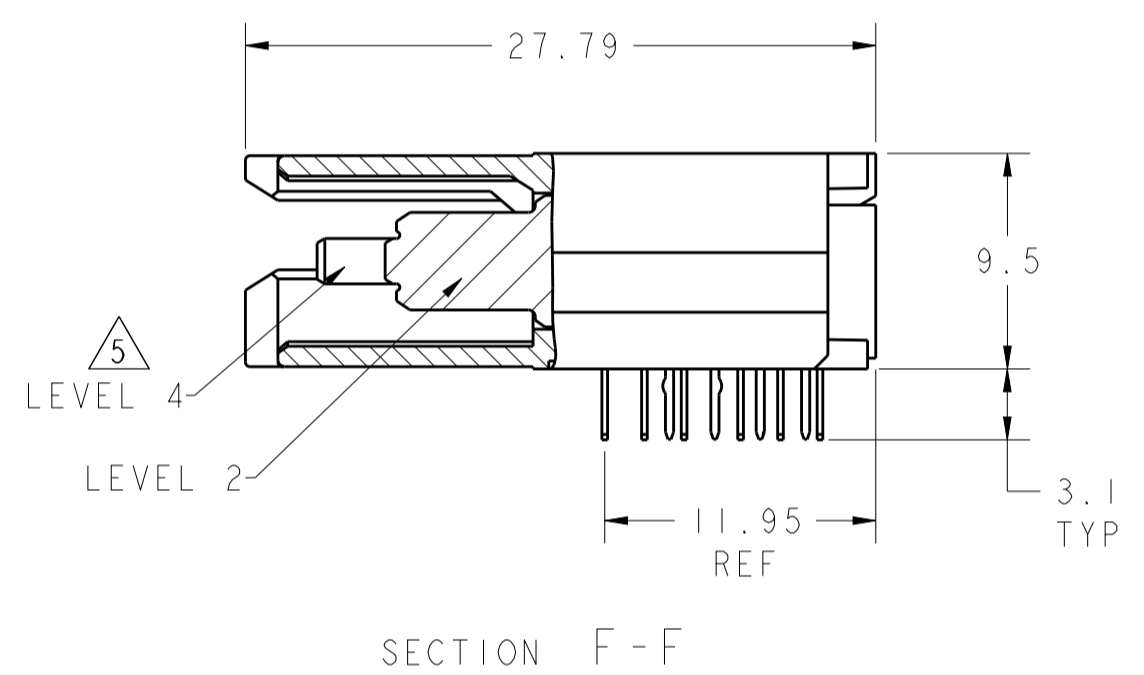
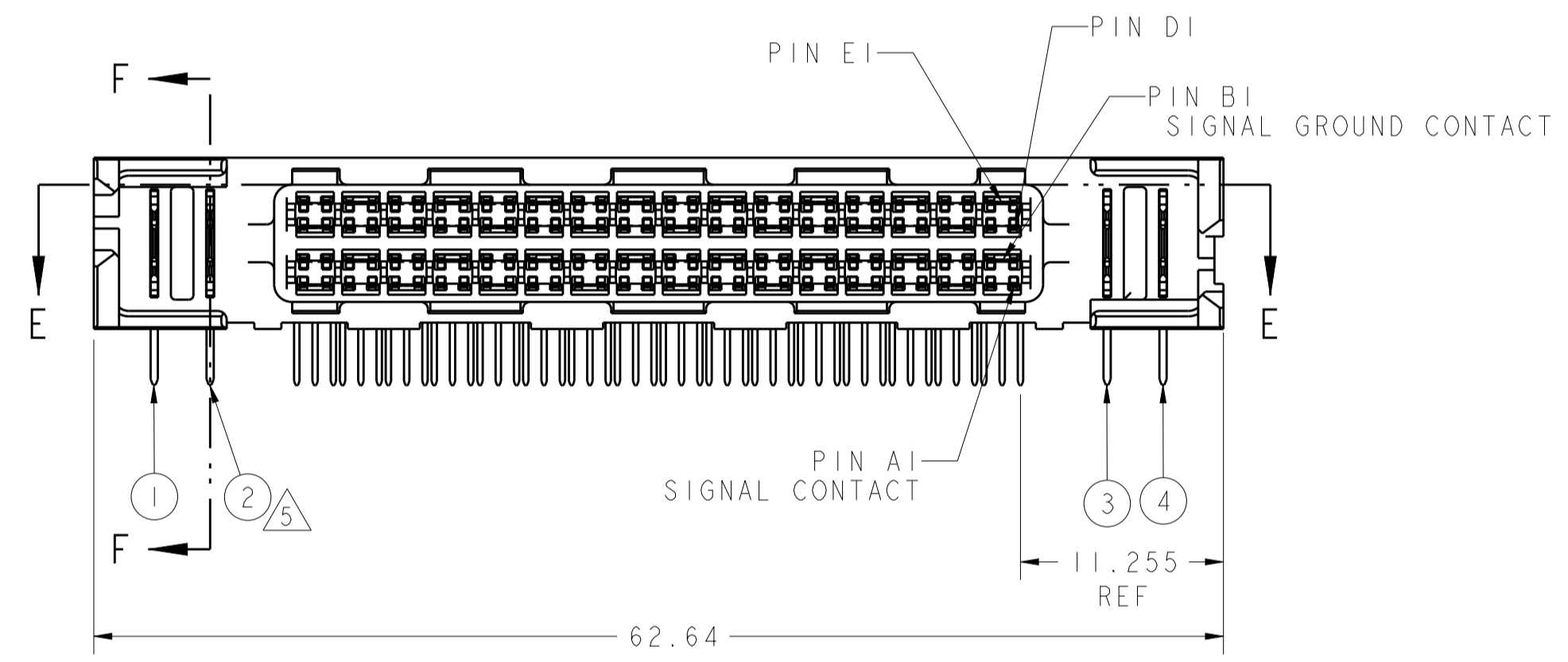

UTILITY CONTACT SEQUENCE TABLE				
UTILITY CONTACT LEVEL 1, 2, 3, OR 4				
2	2	3	3	6367584-4
3	2	2	3	6367584-3
4	1	3	4	6367584-2
4	3	3	4	6367584-1
1	2	3	4	PART NUMBER

UTILITY CONTACT LOCATION

RECOMMENDED PC BOARD FOOTPRINT  
COMPONENT SIDE SHOWN  
SCALE 5:1

THIS DRAWING IS A CONTROLLED DOCUMENT.

DIMENSIONS:	TOLERANCES UNLESS OTHERWISE SPECIFIED:	OWN: C. VALENTINE 14DEC2010	CHK: P. RECCE 14DEC2010	APVD: P. RECCE 14DEC2010
mm	0 PLC ±0.3 1 PLC ±0.3 2 PLC ±0.25 3 PLC ±0.25 4 PLC ±0.25	PRODUCT SPEC	108-1985	APPLICATION SPEC
MATERIAL	FINISH	WEIGHT	114-13068	SIZE: 114-13068
CUSTOMER DRAWING		SCALE: 3:1	SHEET 1 OF 1	REV C

**STE** TE Connectivity

NAME: Z-DOK+ ADAPTER BOARD CONNECTOR ASSEMBLY, 32 SIGNAL DIFF. PAIR, 2 UTILITY CONTACTS PER SIDE

SIZE: 114-13068

WEIGHT: -

SCALE: 3:1

SHEET 1 OF 1

REV C