

THIS DOCUMENT CONTAINS DATA PROPRIETARY TO PROJECTS UNLIMITED, INC. ANY USE OR REPRODUCTION, IN ANY FORM, WITHOUT PRIOR WRITTEN PERMISSION OF PROJECTS UNLIMITED, INC. IS PROHIBITED.  
 © 2005, Projects Unlimited Inc.

REVISIONS			
LTR	DESCRIPTION	DATE	APPROVED
-	RELEASED FROM ENGINEERING	11/19/15	

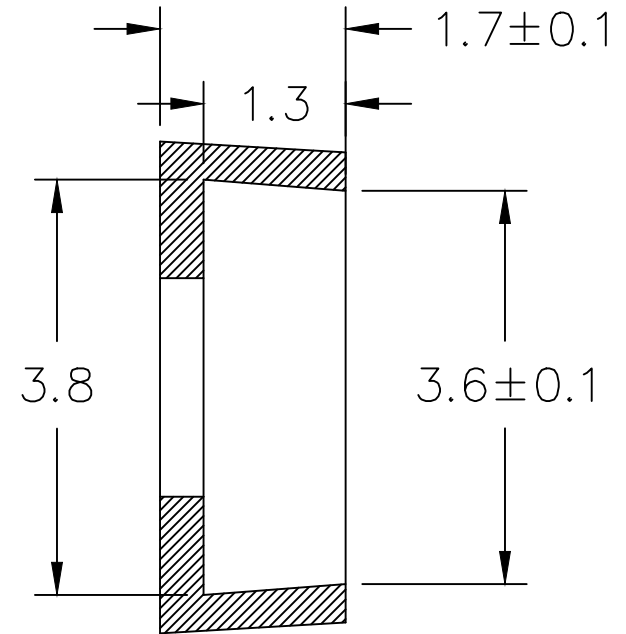
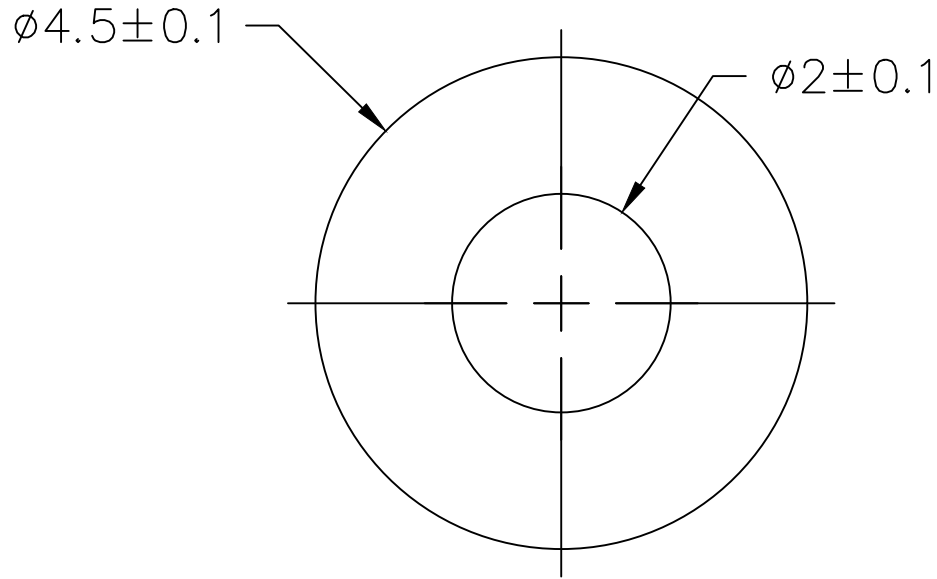

NOTES:

1. ALL DIMENSIONS ARE IN MILLIMETERS.
2. SPECIFICATION SUBJECT TO CHANGE OR WITHDRAWAL WITHOUT NOTICE.
3. MATERIAL: SILICON RUBBER.

FILE NAME  
 MB-4015-LP-2-R.DWG

UNLESS OTHERWISE SPECIFIED: ALL PURCHASES ARE SUBJECT TO THE PUI AUDIO TERMS AND CONDITIONS SALE FOUND AT <a href="http://www.puiaudio.com/pdf/terms_conditions.pdf">http://www.puiaudio.com/pdf/terms_conditions.pdf</a> (paper copy available upon request). DIMENSIONS ARE IN MILLIMETERS, TOLERANCES ARE $\pm 0.5$ AND ANGLES ARE $\pm 3^\circ$ .		 <p><b>pui audio</b>          A Division of Projects Unlimited</p>	3541 Stop Eight Road Dayton, Ohio 45414
APPROVALS DRAWN <i>M.L.</i> CHECKED <i>M.L.</i> APPROVED <i>B.R.</i>	DATE 11/15 11/15 11/15		
		SIZE A	SHEET 1 OF 1