



ANATECH ELECTRONICS INC
RF & Microwave Filters & Products

948.3 MHz Cavity Bandpass Filter

Part Number: AE948B1172



Electrical Specifications

Center Frequency: 948.3 MHz
1 dB Bandwidth: 4 MHz(946.3-950.3 MHz)
Insertion Loss: <4dB (3.0 dB typical)
Passband Return Loss: 18dB
Passband Ripple: <0.2dB
Rejection: ≥ 40 dB @ 938.3-943.3 MHz (45dB typical)
Power Handling: 20 W CW, 200 W peak
Input / Output Impedance: 50 Ohms

Mechanical

Mounting Method: 4-40 UNC Threaded Holes
Connector Type: SMA (F)
Dimensions: 79 x 54 x 40 mm

Environmental

Operating Temperature: 0°C to +50°C
Storage Temperature: -55°C to +85°C
Shock: 20 G. 11ms
Vibration: 20 G. 5 to 200Hz

Outline Drawing:

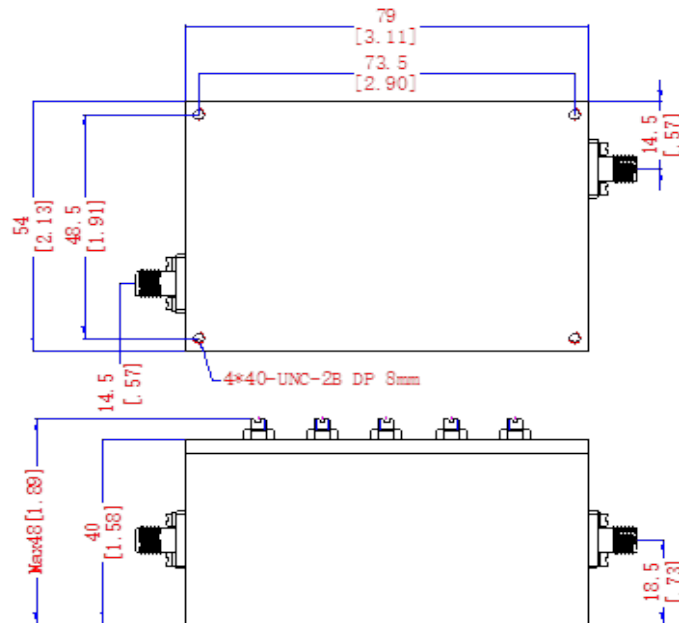



Simulation Plot:

