

OV14810 14 megapixel product brief



14.6 Megapixel Photography and Full 1080p High-Definition Video



available in
a lead-free
package

The OV14810 is the ultimate solution for high quality point-and-shoot photography and full HD video recording, combining 14.6-megapixel photography with 1080p/60 HD video recording. The 1/2.33-inch OV14810 utilizes OmniVision's most advanced 1.4-micron OmniBSI™ pixel architecture to achieve optimal performance and low-light sensitivity in the industry's smallest format. The OV14810 has an active array of 4416 x 3312 backside illumination pixels operating at 15 fps in full resolution, while delivering full 1080p HD video at 60 fps, using a binning feature to achieve higher sensitivity. In full HD video mode, the sensor also provides additional pixels used for electronic image stabilization (EIS).

The OV14810's 9° chief ray angle (CRA) optimizes it for use in DSC and DVC applications. The sensor's small form factor is largely attributable to its CSP3 packaging,

allowing for the development of ultra compact cameras. The OV14810 enables camera designs with a low bill of materials and reduced power consumption. It is offered with industry-standard connectivity including LVDS, MIPI and DVP and does not require external IC components.

All required image processing functions, including exposure control, white balance, defective pixel canceling, noise canceling are programmable through the SCCB interface. In addition, OmniVision image sensors use proprietary sensor technology to improve image quality by reducing or eliminating common lighting/electrical sources of image contamination, such as fixed pattern noise and smearing to produce a clean, fully stable color image.

Find out more at www.ovt.com.

Applications

- Digital Still Cameras (DSC)
- Digital Video Camcorders (DVC)

Product Features

- ultra high performance
- support for binning
- automatic image control functions:
 - automatic exposure control (AEC)
 - automatic gain control (AGC)
 - automatic white balance (AWB)
 - automatic band filter (ABF)
 - automatic 50/60 Hz luminance detection
 - automatic black level calibration (ABLC)
- standard serial SCCB interface
- digital video port (DVP) parallel output interface
- programmable controls for frame rate, mirror and flip, cropping, and windowing
- LVDS serial output interface
- MIPI serial output interface
- image quality controls: lens correction and defective pixel canceling
- embedded one-time programmable (OTP) memory for part identification, etc.
- on-chip phase lock loop (PLL)
- support for output formats: 9/10/11/12-bit RAW RGB (DVP), 9/10/11/12-bit RAW RGB (MIPI/LVDS), CCIR656
- programmable I/O drive capability
- built-in 1.5 V regulator for core
- support for horizontal and vertical subsampling
- support for images sizes: 14.6 Mpixel, 12.7 Mpixel, electronic image stabilization (EIS) 1080p, 1080p, EIS720p, 720p, VGA, QVGA, etc.

OV14810

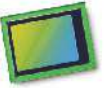

Ordering Information

- OV14810-A16A (color, lead-free, 116-pin CSP3)

Product Specifications

- active array size: 4416 x 3312
- maximum image transfer rate:
 - 14.6M (10-bit): 15 fps
 - EIS1080p (9-bit): 60 fps
- power supply:
 - core: 1.5 VDC $\pm 5\%$ (internal regulator option)
 - analog: 2.6 ~3.0 V
 - I/O: 1.7 ~3.0 V
- sensitivity: >650 mV/(lux-sec)
- scan mode: progressive
- temperature range:
 - operating: -30°C to 70°C
 - stable image: 0°C to 50°C
- maximum exposure interval: $3336 \times t_{ROW}$
- pixel size: $1.4 \mu\text{m} \times 1.4 \mu\text{m}$
- output formats: 9/10/11/12-bit RAW (DVP), 9/10/11/12-bit RAW (MIPI/LVDS)
- well capacity: 4.5 Ke^-
- lens size: 1/2.33"
- dark current: 7.6 mV/sec at 60°C
- lens chief ray angle: 9°
- fixed pattern noise (FPN): $<1\%$ of $V_{PEAK-TO-PEAK}$
- input clock frequency: 6 ~27 MHz
- image area: $6227 \mu\text{m} \times 4653 \mu\text{m}$
- S/N ratio: 35 dB
- package dimensions: $8935 \mu\text{m} \times 6975 \mu\text{m}$
- dynamic range: 67 dB

Functional Block Diagram

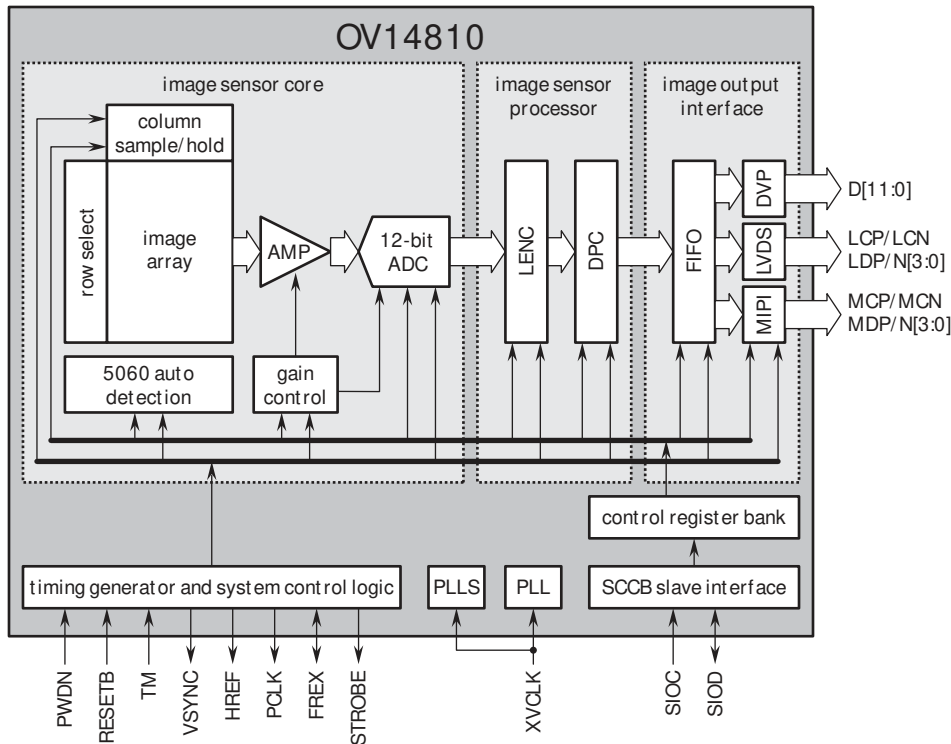

4275 Burton Drive
Sant a Clara, CA 95054
USA

Tel: +1 408 567 3000
Fax: +1 408 567 3001
www.ovt.com

OmniVision reserves the right to make changes to their products or to discontinue any product or service without further notice. OmniVision is a registered trademark of OmniVision Technologies, Inc. The OmniVision logo and OmniBSI are trademarks of OmniVision Technologies, Inc. All other trademarks are the property of their respective owners.

OmniVision