

TPA2025D1 Audio Power Amplifier Evaluation Module

This document describes the operation of the TPA2025D1 evaluation module that users may use to evaluate the TPA2025D1 Audio Power Amplifier. Included are the TPA2025D1EVM schematic, board art, and bill of materials.

Contents

| | | |
|-----|--|---|
| 1 | Introduction | 1 |
| 1.1 | Description | 1 |
| 1.2 | TPA2025D1 Specifications | 2 |
| 2 | Operation | 2 |
| 2.1 | Quick-Start List for Stand-Alone Operation | 2 |
| 2.2 | Boost Settings | 3 |
| 2.3 | Power Up | 4 |
| 3 | Reference | 5 |
| 3.1 | TPA2025D1EVM Schematic | 5 |
| 3.2 | TPA2025D1EVM PCB Layers | 6 |
| 3.3 | TPA2025D1EVM Bill of Materials | 9 |

List of Figures

| | | |
|---|-----------------------------|---|
| 1 | TPA2025D1EVM Schematic..... | 5 |
| 2 | EVM Assembly Layer..... | 6 |
| 3 | EVM Top Layer..... | 6 |
| 4 | EVM Layer 2..... | 7 |
| 5 | EVM Layer 3..... | 7 |
| 6 | EVM Bottom Layer..... | 8 |

List of Tables

| | | |
|---|-------------------------------------|---|
| 1 | TPA2025D1EVM Bill of Materials..... | 9 |
|---|-------------------------------------|---|

1 Introduction

This section provides an overview of the Texas Instruments (TI) TPA2025D1 audio power amplifier evaluation module (EVM). It includes a brief description of the module and a list of specifications.

1.1 Description

The TPA2025D1 is a high-efficiency, class-D, audio power amplifier and an integrated boost converter. It drives up to 2 W into a 4-Ω speaker from low supply voltages.

The TPA2025D1 audio power amplifier EVM is a complete, stand-alone audio amplifier. It contains the TPA2025D1 WCSP (YZG) Class-D audio power amplifier with an integrated boost converter. All components and the EVM are Pb-Free.

1.2 TPA2025D1 Specifications

| | | |
|-----------|---|------------------|
| V_{BAT} | Supply voltage range | 2.5 V to 5.2 V |
| I_{DD} | Supply current | 3 A Maximum |
| P_O | Continuous output power per channel, 4 Ω , $V_{BAT} = 3.6$ V | 2 W |
| V_I | Audio input voltage | 0 V to V_{BAT} |
| R_L | Minimum load impedance | 4 Ω |

2 Operation

This section describes how to operate the TPA2025D1EVM.

2.1 Quick-Start List for Stand-Alone Operation

Use the following steps when operating the TPA2025D1EVM as a stand-alone or when connecting the EVM into existing circuits or equipment.

2.1.1 Power and Ground

1. Ensure the external power sources are set to OFF.
2. Set the power supply voltage between 2.3 V and 5.2 V. When connecting the power supply to the EVM, attach the power supply ground connection to the GND connector first, and then connect the positive supply to the VDD connector. Verify that correct connections are made to the banana jacks.

2.1.2 Audio

1. Ensure that the audio source is set to the minimum level.
2. Connect the audio source to the input RCA jack **IN**. In case of differential audio input, ensure that the jumper, **JP SE**, is not inserted. In case of a single-ended audio input, ensure that the jumper, **JP SE**, is inserted, thereby grounding IN+ through the input capacitor C2.
3. Connect a speaker (4 Ω to 32 Ω) to the output banana jacks, **OUT+** and **OUT-**.
4. **FLT Out+** and **FLT Out-** test points allow the user to connect the outputs of the amplifier through an RC filter for audio measurements. (Many audio analyzers will not give the correct readings on a Class-D amplifier without additional filtering.) Note that the user must provide the necessary resistors, R7 and R8 to complete the filters. The typical value for R7 and R8 is 1.0 k Ω .
5. The filtered output of the TPA2025D1 can be measured between test points **FILT OUT-** and **FILT OUT+**

2.1.3 AGC Control

The TPA2025D1 has three selectable inflection point settings: 3.25 V, 3.55 V, and 3.75 V.

1. Remove the jumper, **AGC**, to select the 3.25-V inflection point (AGC1).
2. Install the jumper, **AGC**, between pins 2 and 3 to select the 3.55-V inflection point (AGC2).
3. Install the jumper, **AGC**, between pins 1 and 2 to select the 3.75-V inflection point (AGC3).

2.1.4 Amplifier Gain

The TPA2025D1 has a fixed setting of 20 dB.

2.1.5 Shutdown Controls

1. The TPA2025D1 provides shutdown control for the Class-D amplifier and the boost converter. The EN pin enables the boost converter and Class-D amplifier. It is active high.
2. Press and hold pushbutton **S1** to place the boost converter and the Class-D amplifier in shutdown. Release pushbutton **S1** to activate the Class-D amplifier and boost converter. The boost converter only turns on if an audio signal ($> 2 V_{PEAK}$) is present at one of the outputs (OUT+ or OUT-).

NOTE: The TPA2025D1 has an auto pass-through mode. Under normal operation (EN = HIGH), the boost converter automatically turns off if no audio signal is present at one of the inputs (IN+ or IN-).

2.2 Boost Settings

The default voltage for the boost converter is 5.9 V (unloaded) and cannot be changed. If no audio signal is present, the boost converter is automatically disabled. Once the audio signal is present at IN+ and IN-, the boost converter enables automatically, when the output signal exceeds $2 V_{PEAK}$.

2.2.1 Boost Terms

The following is a list of terms and definitions:

| | |
|--------------|--|
| C_{MIN} | Minimum boost capacitance required for a given ripple voltage on PVOUT (PVDD) |
| L | Boost inductor |
| f_{boost} | Switching frequency of the boost converter |
| I_{PVDD} | Current pulled by the class-D amplifier from the boost converter |
| I_{PVDD} | Current pulled by the class-D amplifier from the boost converter |
| I_L | Current through the boost inductor. |
| PVDD (PVOUT) | Supply voltage for the class-D amplifier (Voltage generated by the boost converter output) |
| VBAT (VDD) | Supply voltage to the TPA2025D1 (Supply voltage to the EVM). |
| ΔI_L | Ripple current through the inductor. |
| ΔV | Ripple voltage on PVOUT (PVDD) due to capacitance |

2.2.2 Changing the Boost Inductor

Working inductance decreases as inductor current increases. If the drop in working inductance is severe enough, it may cause the boost converter to become unstable, or cause the TPA2025D1 to reach its current limit at a lower output power than expected. Inductor vendors specify currents at which inductor values decrease by a specific percentage. This can vary by 10% to 35%. Inductance is also affected by dc current and temperature.

Inductor current rating is determined by the requirements of the load. The inductance is determined by two factors: the minimum value required for stability and the maximum ripple current permitted in the application.

Use [Equation 1](#) to determine the required current rating. [Equation 1](#) shows the approximate relationship between the average inductor current, I_L , to the load current, load voltage, and input voltage (I_{PVDD} , PVOUT, and VBAT, respectively.) Insert I_{PVDD} , PVDD, and VBAT into [Equation 1](#) to solve for I_L . The inductor must maintain at least 90% of its initial inductance value at this current.

$$I_L = I_{PVDD} \times \left(\frac{PVDD}{VBAT \times 0.8} \right) \quad (1)$$

The minimum working inductance is 1.3 μ H. A lower value may cause instability.

Ripple current, ΔI_L , is peak-to-peak variation in inductor current. Smaller ripple current reduces core losses in the inductor as well as the potential for EMI. Use [Equation 2](#) to determine the value of the inductor, L. [Equation 2](#) shows the relationships among inductance L, VBAT, PVDD, the switching frequency, f_{boost} , and ΔI_L . Insert the maximum acceptable ripple current into [Equation 2](#) to solve for L.

$$L = \frac{VBAT \times (PVDD - VBAT)}{\Delta I_L \times f_{BOOST} \times PVDD} \quad (2)$$

ΔI_L is inversely proportional to L. Minimize ΔI_L as much as is necessary for a specific application. Increase the inductance to reduce the ripple current. Note that making the inductance too large prevents the boost converter from responding to fast load changes properly. Typical inductor values for the TPA2025D1 are 2.2 μH to 4.7 μH .

Select an inductor with a small dc resistance, DCR. DCR reduces the output power due to the voltage drop across the inductor.

2.2.3 Changing the Boost Capacitor

The value of the boost capacitor is determined by the minimum value of working capacitance required for stability and the maximum voltage ripple allowed on PVOOUT in the application. The minimum value of working capacitance is 4.7 μF . Do not use any component with a working capacitance less than 4.7 μF . Working capacitance is defined as the rated capacitance reduced by the DC Bias factor, temperature, and aging parameters of the capacitor being used. It may be necessary to request these parameters from the capacitor manufacturer. For best performance, only consider ceramic capacitors with X5R or X7R dielectric.

For X5R or X7R ceramic capacitors, Equation 3 shows the relationships among the boost capacitance, C, to load current, load voltage, ripple voltage, input voltage, and switching frequency (I_{PVOOUT} , PVOOUT, ΔV , VDD, f_{boost} respectively). Insert the maximum allowed ripple voltage into Equation 3 to solve for C. A factor of about 1.5 is included to account for capacitance loss due to dc voltage and temperature.

$$C = 1.5 \times \frac{I_{PVDD} \times (PVDD - VBAT)}{\Delta V \times f_{\text{BOOST}} \times PVDD} \quad (3)$$

For aluminum or tantalum capacitors, Equation 4 shows the relationships among the boost capacitance, C, to load current, load voltage, ripple voltage, input voltage, and switching frequency (I_{PVOOUT} , PVOOUT, ΔV , VDD, f_{boost} respectively). Insert the maximum allowed ripple voltage into Equation 4 to solve for C. Solve this equation assuming ESR is zero.

$$C = \frac{I_{PVDD} \times (PVDD - VBAT)}{\Delta V \times f_{\text{BOOST}} \times PVDD} \quad (4)$$

Capacitance of aluminum and tantalum capacitors is normally insensitive to applied voltage, so no factor of 1.5 is included in Equation 4. However, the ESR in aluminum and tantalum capacitors can be significant. Choose an aluminum or tantalum capacitor with an ESR around 30 m Ω . For best performance with tantalum capacitors, use at least a 10-V rating. Note that tantalum capacitors must generally be used at voltages of half their ratings or less.

2.3 Power Up

1. Verify that the correct connections are as described in Section 2.1.
2. Verify that the voltage setting of the power supply is between 2.5 V and 5.2 V, and turn on the power supply. Proper operation of the EVM begins.
3. Adjust the audio signal source as needed.

3 Reference

This section includes the EVM schematic, board layout reference, and parts list.

3.1 TPA2025D1EVM Schematic

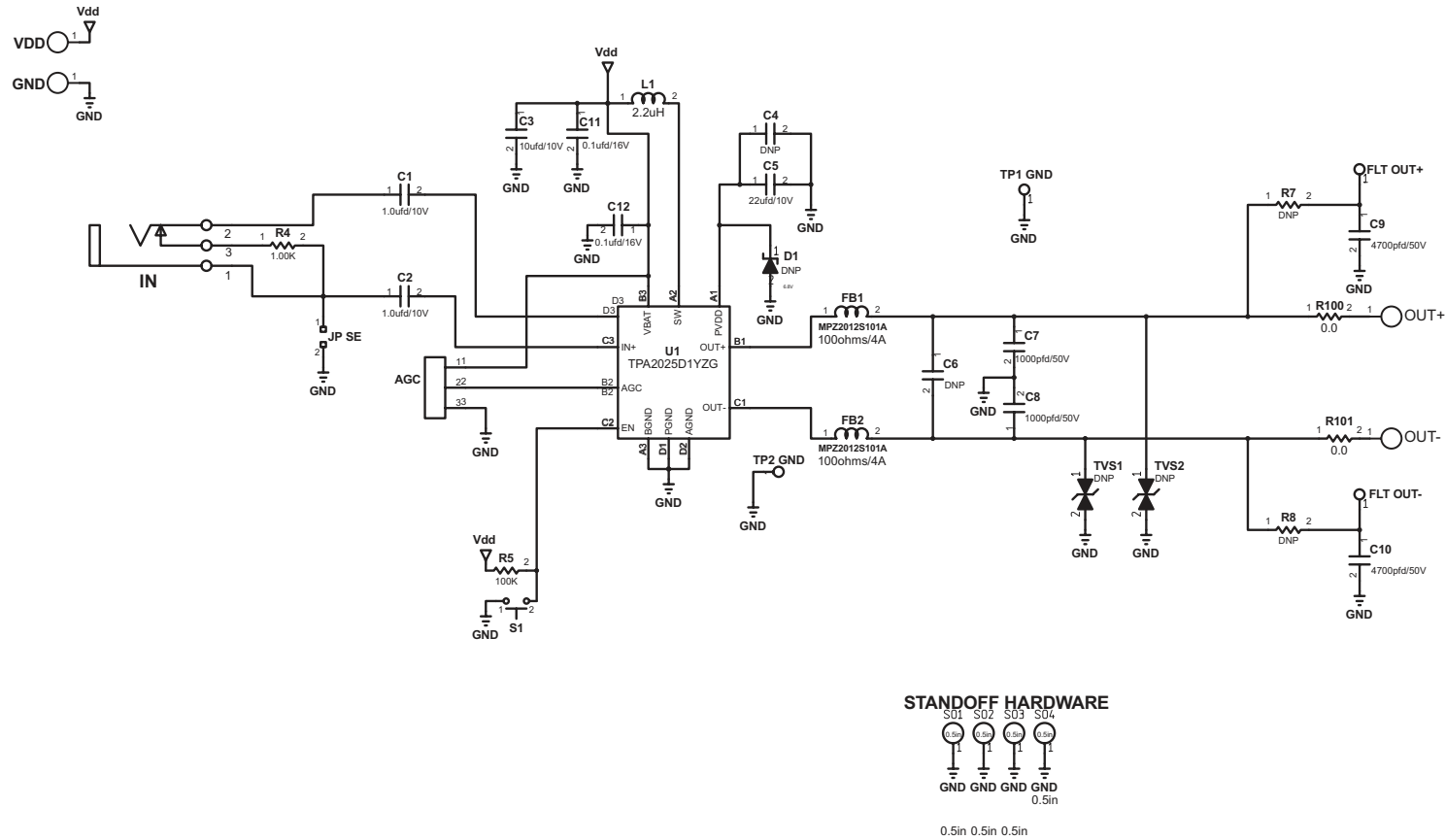

Figure 1. TPA2025D1EVM Schematic

3.2 TPA2025D1EVM PCB Layers

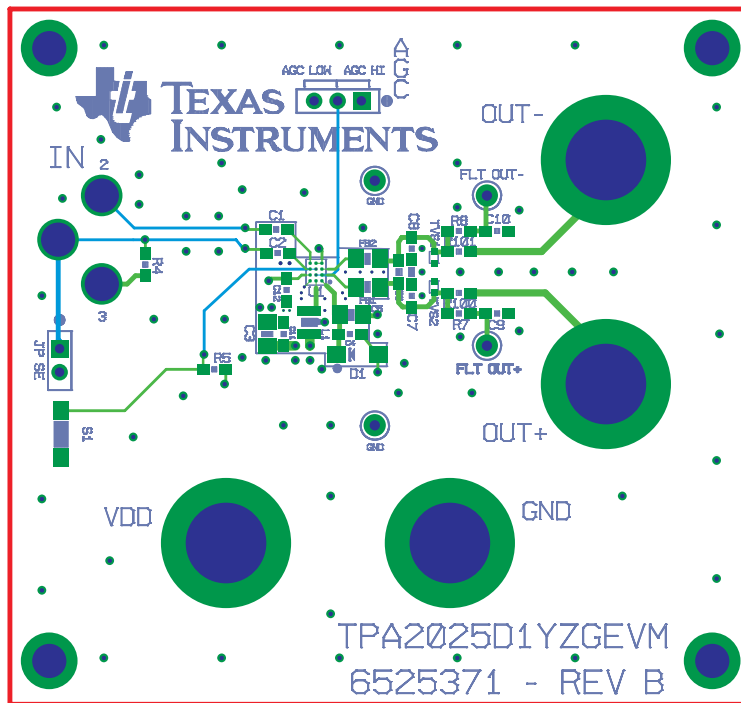

Figure 2. EVM Assembly Layer

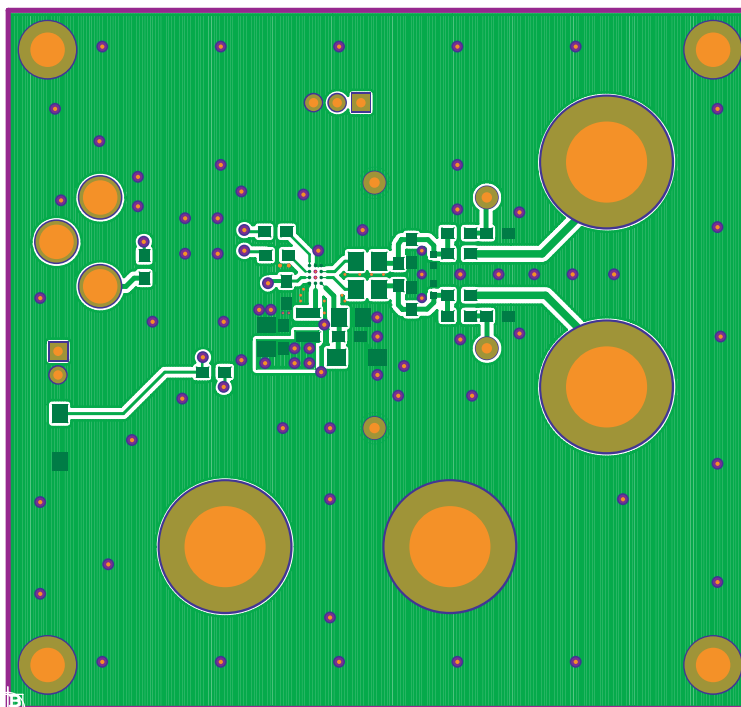

Figure 3. EVM Top Layer

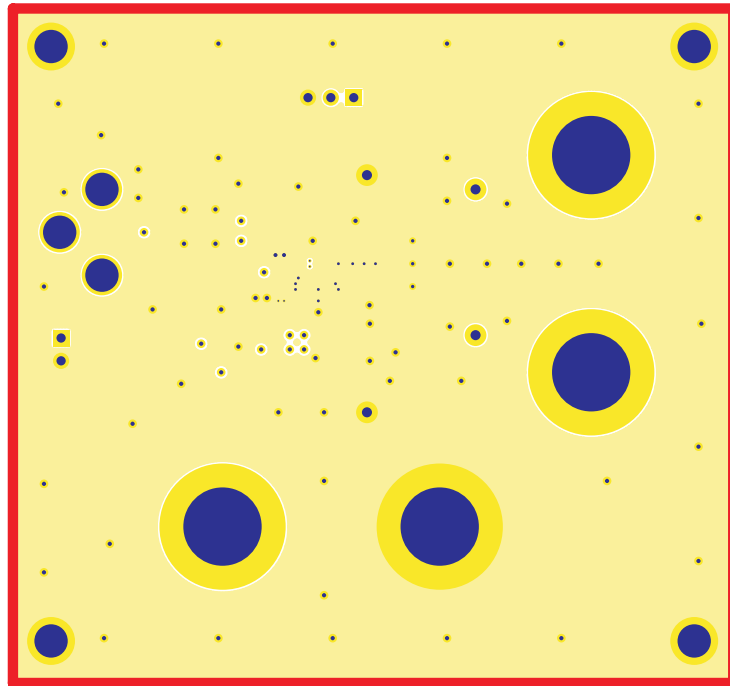

Figure 4. EVM Layer 2

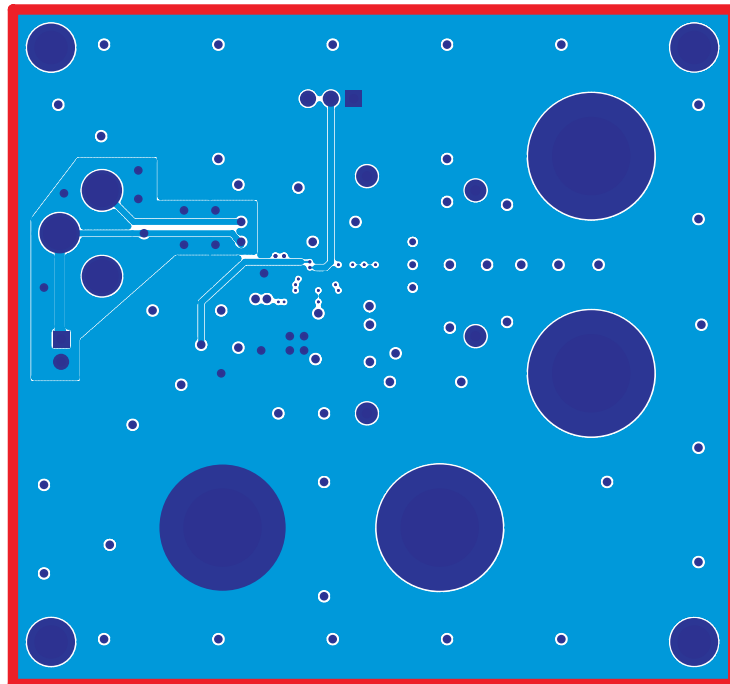

Figure 5. EVM Layer 3

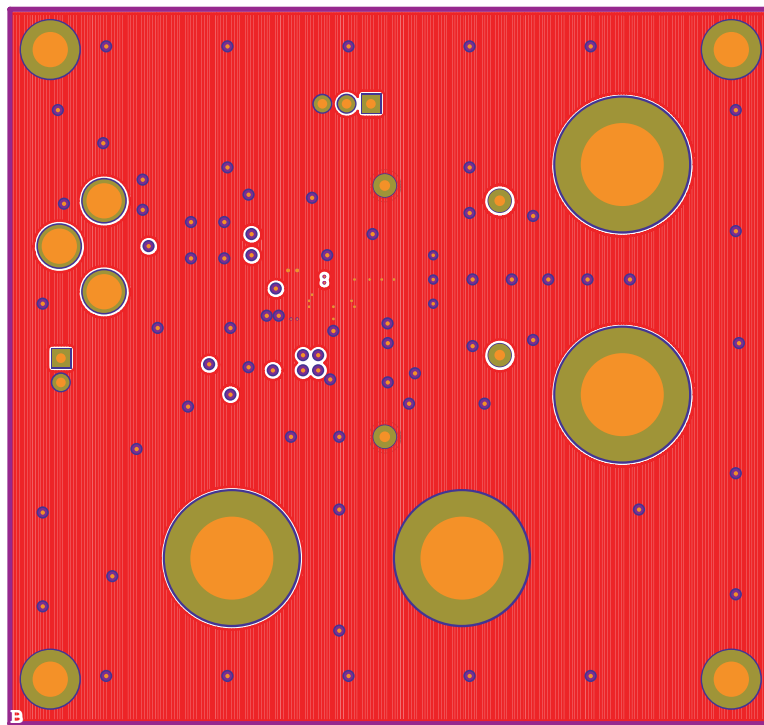

Figure 6. EVM Bottom Layer

3.3 TPA2025D1EVM Bill of Materials

Table 1. TPA2025D1EVM Bill of Materials

| ITEM | MANU PARTNUM | QTY | REF DESIGNATORS | VENDOR PARTNUM | DESCRIPTION | VENDOR | MANUFACTURER |
|-----------------------|--------------------|---------|-----------------|------------------|---|-------------------|---------------------|
| 1 | TPA2025D1YZG | 1 | U1 | TPA2025D1YZG | Audio Power Amplifier | TEXAS INSTRUMENTS | TEXAS INSTRUMENTS |
| SEMICONDUCTORS | | | | | | | |
| 2 | ESDALC6V1-1BT2 | (0) DNP | TVS1,TVS2 | ESDALC6V1-1BT2 | TRANSIENT VOLTAGE SUPPRESSION BIDIR 6.1V 9A SOD-882 ROHS | MOUSER | ST MICROELECTRONICS |
| CAPACITORS | | | | | | | |
| 3 | C1608C0G1H102J | 2 | C7,C8 | 445-1293-1 | CAP SMD0603 CERM 1000PFD 50V 5% COG ROHS | DIGI-KEY | TDK CORP. |
| 4 | ECJ-1VB1H472K | 2 | C9,C10 | PCC1780CT | CAP SMD0603 CERM 4700PFD 50V 10% X7R ROHS | DIGI-KEY | PANASONIC |
| 5 | GRM21BR71A106KE51L | 1 | C3 | 490-3905-1 | CAP SMD0805 CERM 10UFD 10V10% X7R ROHS | DIGI-KEY | MURATA |
| 6 | LMK212BJ226MG-T | 1 | C5 | 587-1958-1 | CAP SMD0805 CERM 22UFD 10V 20% X5R ROHS | DIGI-KEY | TAIYO YUDEN |
| 7 | ECJ-1VB1C104K | 2 | C11,C12 | PCC1762CT | CAP SMD0603 CERM 0.1UFD 16V 10% X7R ROHS | DIGI-KEY | PANASONIC |
| 8 | GRM185R61A105KE36D | 2 | C1,C2 | 490-3893-1 | CAP SMD0603 CERM 1.0UFD 10V 10% X5R ROHS | DIGI-KEY | MURATA |
| RESISTORS | | | | | | | |
| 9 | ERJ-3GEYJ104V | 1 | R5 | P100KGCT | RESISTOR SMD0603 100K OHM 5% THICK FILM 1/10W ROHS | DIGI-KEY | PANASONIC |
| 10 | RC0603FR-071KL | 1 | R4 | 311-1.00KHRCT | RESISTOR SMD0603 THICK FILM 1.00K OHM 1% 1/10W ROHS | DIGI-KEY | YAGEO |
| 11 | ERJ-3GEY0R00V | 2 | R100,R101 | P0.0GCT | RESISTOR SMD0603 0.0 OHM 5% THICK FILM 1/10W ROHS | DIGI-KEY | PANASONIC |
| INDUCTORS | | | | | | | |
| 12 | 1239AS-H-2R2N=P2 | 1 | L1 | 1239AS-H-2R2N=P2 | INDUCTOR POWER SMD1008 2.2uH RDC=80mOHMS 2.3A DFE252012C ROHS | TOKO JAPAN | TOKO JAPAN |
| 13 | MMSZ5235BT1 | (0) DNP | D1 | | ZENER DIODE,6.8V,SMT SOD-123 | | |
| 14 | MPZ2012S101A | 2 | FB1,FB2 | 445-1567-1 | FERRITE BEAD, 100 Ohms 4A 100MHz SM0805 ROHS | DIGI-KEY | TDK |

Table 1. TPA2025D1EVM Bill of Materials (continued)

| ITEM | MANU PARTNUM | QTY | REF DESIGNATORS | VENDOR PARTNUM | DESCRIPTION | VENDOR | MANUFACTURER |
|-----------------------------------|-----------------|-----|---------------------------|----------------|---|----------|----------------------|
| HEADERS, JACKS, AND SHUNTS | | | | | | | |
| 15 | 26630301RP2 | 1 | AGC | 2663S-03 | HEADER 3 PIN, PCB 2.0MM ROHS | DIGI-KEY | NORCOMP |
| 16 | 26630201RP2 | 1 | JP SE | 2663S-02 | HEADER 2 PIN, PCB 2.0MM ROHS | DIGI-KEY | NORCOMP |
| 17 | PJРАН1X1U01X | 1 | IN | 65K7770 | JACK, RCA 3-PIN PCB-RA BLACK ROHS | NEWARK | SWITCHCRAFT |
| 18 | 810-002-SP2L001 | 2 | JP SE, AGC ⁽¹⁾ | SP2-001E | SHUNT, BLACK AU FLASH 2 MM ROHS | DIGI-KEY | NORCOMP |
| TESTPOINTS AND SWITCHES | | | | | | | |
| 19 | 5002 | 1 | FLT OUT- | 5002K | PC TESTPOINT, WHITE, ROHS | DIGI-KEY | KEYSTONE ELECTRONICS |
| 20 | 5001 | 2 | TP1 GND,TP2 GND | 5001K | PC TESTPOINT, BLACK, ROHS | DIGI-KEY | KEYSTONE ELECTRONICS |
| 21 | 5000 | 1 | FLT OUT+ | 5000K | PC TESTPOINT, RED, ROHS | DIGI-KEY | KEYSTONE ELECTRONICS |
| STANDOFFS AND HARDWARE | | | | | | | |
| 22 | TL1015AF160QG | 1 | S1 | EG4344CT | SWITCH, MOM, 160G SMT 4X3MM ROHS | DIGI-KEY | E-SWITCH |
| 23 | 2027 | 4 | SO1,SO2,SO3,SO4 | 2027K | STANDOFF,4-40,0.5INx3/16IN,ALUM RND F-F | DIGI-KEY | KEYSTONE ELECTRONICS |
| 24 | 111-2223-001 | 4 | GND, VDD, OUT+, OUT- | J587 | BINDING-POST,NONINS,THRU,ROHS | DIGI-KEY | EMERSON NPCS |
| COMPONENTS NOT ASSEMBLED | | | | | | | |
| 25 | R0603_DNP | 2 | R7, R8 | | | | |
| 26 | C0603_DNP | 2 | C4, C6 | | | | |

⁽¹⁾ Place Shunts Only On Pin2 of JP SE and on Pin3 of AGC

Evaluation Board/Kit Important Notice

Texas Instruments (TI) provides the enclosed product(s) under the following conditions:

This evaluation board/kit is intended for use for **ENGINEERING DEVELOPMENT, DEMONSTRATION, OR EVALUATION PURPOSES ONLY** and is not considered by TI to be a finished end-product fit for general consumer use. Persons handling the product(s) must have electronics training and observe good engineering practice standards. As such, the goods being provided are not intended to be complete in terms of required design-, marketing-, and/or manufacturing-related protective considerations, including product safety and environmental measures typically found in end products that incorporate such semiconductor components or circuit boards. This evaluation board/kit does not fall within the scope of the European Union directives regarding electromagnetic compatibility, restricted substances (RoHS), recycling (WEEE), FCC, CE or UL, and therefore may not meet the technical requirements of these directives or other related directives.

Should this evaluation board/kit not meet the specifications indicated in the User's Guide, the board/kit may be returned within 30 days from the date of delivery for a full refund. **THE FOREGOING WARRANTY IS THE EXCLUSIVE WARRANTY MADE BY SELLER TO BUYER AND IS IN LIEU OF ALL OTHER WARRANTIES, EXPRESSED, IMPLIED, OR STATUTORY, INCLUDING ANY WARRANTY OF MERCHANTABILITY OR FITNESS FOR ANY PARTICULAR PURPOSE.**

The user assumes all responsibility and liability for proper and safe handling of the goods. Further, the user indemnifies TI from all claims arising from the handling or use of the goods. Due to the open construction of the product, it is the user's responsibility to take any and all appropriate precautions with regard to electrostatic discharge.

EXCEPT TO THE EXTENT OF THE INDEMNITY SET FORTH ABOVE, NEITHER PARTY SHALL BE LIABLE TO THE OTHER FOR ANY INDIRECT, SPECIAL, INCIDENTAL, OR CONSEQUENTIAL DAMAGES.

TI currently deals with a variety of customers for products, and therefore our arrangement with the user **is not exclusive**.

TI assumes **no liability for applications assistance, customer product design, software performance, or infringement of patents or services described herein.**

Please read the User's Guide and, specifically, the Warnings and Restrictions notice in the User's Guide prior to handling the product. This notice contains important safety information about temperatures and voltages. For additional information on TI's environmental and/or safety programs, please contact the TI application engineer or visit www.ti.com/esh.

No license is granted under any patent right or other intellectual property right of TI covering or relating to any machine, process, or combination in which such TI products or services might be or are used.

FCC Warning

This evaluation board/kit is intended for use for **ENGINEERING DEVELOPMENT, DEMONSTRATION, OR EVALUATION PURPOSES ONLY** and is not considered by TI to be a finished end-product fit for general consumer use. It generates, uses, and can radiate radio frequency energy and has not been tested for compliance with the limits of computing devices pursuant to part 15 of FCC rules, which are designed to provide reasonable protection against radio frequency interference. Operation of this equipment in other environments may cause interference with radio communications, in which case the user at his own expense will be required to take whatever measures may be required to correct this interference.

EVM Warnings and Restrictions

It is important to operate this EVM within the input voltage range of -0.3 V to 6 V and the output voltage range of -0.3 V to $V_{DD} + 0.3\text{ V}$.

Exceeding the specified input range may cause unexpected operation and/or irreversible damage to the EVM. If there are questions concerning the input range, please contact a TI field representative prior to connecting the input power.

Applying loads outside of the specified output range may result in unintended operation and/or possible permanent damage to the EVM. Please consult the EVM User's Guide prior to connecting any load to the EVM output. If there is uncertainty as to the load specification, please contact a TI field representative.

During normal operation, some circuit components may have case temperatures greater than 85°C . The EVM is designed to operate properly with certain components above 85°C as long as the input and output ranges are maintained. These components include but are not limited to linear regulators, switching transistors, pass transistors, and current sense resistors. These types of devices can be identified using the EVM schematic located in the EVM User's Guide. When placing measurement probes near these devices during operation, please be aware that these devices may be very warm to the touch.

EVALUATION BOARD/KIT/MODULE (EVM) ADDITIONAL TERMS

Texas Instruments (TI) provides the enclosed Evaluation Board/Kit/Module (EVM) under the following conditions:

The user assumes all responsibility and liability for proper and safe handling of the goods. Further, the user indemnifies TI from all claims arising from the handling or use of the goods.

Should this evaluation board/kit not meet the specifications indicated in the User's Guide, the board/kit may be returned within 30 days from the date of delivery for a full refund. THE FOREGOING LIMITED WARRANTY IS THE EXCLUSIVE WARRANTY MADE BY SELLER TO BUYER AND IS IN LIEU OF ALL OTHER WARRANTIES, EXPRESSED, IMPLIED, OR STATUTORY, INCLUDING ANY WARRANTY OF MERCHANTABILITY OR FITNESS FOR ANY PARTICULAR PURPOSE. EXCEPT TO THE EXTENT OF THE INDEMNITY SET FORTH ABOVE, NEITHER PARTY SHALL BE LIABLE TO THE OTHER FOR ANY INDIRECT, SPECIAL, INCIDENTAL, OR CONSEQUENTIAL DAMAGES.

Please read the User's Guide and, specifically, the Warnings and Restrictions notice in the User's Guide prior to handling the product. This notice contains important safety information about temperatures and voltages. For additional information on TI's environmental and/or safety programs, please visit www.ti.com/esh or contact TI.

No license is granted under any patent right or other intellectual property right of TI covering or relating to any machine, process, or combination in which such TI products or services might be or are used. TI currently deals with a variety of customers for products, and therefore our arrangement with the user is not exclusive. TI assumes no liability for applications assistance, customer product design, software performance, or infringement of patents or services described herein.

REGULATORY COMPLIANCE INFORMATION

As noted in the EVM User's Guide and/or EVM itself, this EVM and/or accompanying hardware may or may not be subject to the Federal Communications Commission (FCC) and Industry Canada (IC) rules.

For EVMs **not** subject to the above rules, this evaluation board/kit/module is intended for use for ENGINEERING DEVELOPMENT, DEMONSTRATION OR EVALUATION PURPOSES ONLY and is not considered by TI to be a finished end product fit for general consumer use. It generates, uses, and can radiate radio frequency energy and has not been tested for compliance with the limits of computing devices pursuant to part 15 of FCC or ICES-003 rules, which are designed to provide reasonable protection against radio frequency interference. Operation of the equipment may cause interference with radio communications, in which case the user at his own expense will be required to take whatever measures may be required to correct this interference.

General Statement for EVMs including a radio

User Power/Frequency Use Obligations: This radio is intended for development/professional use only in legally allocated frequency and power limits. Any use of radio frequencies and/or power availability of this EVM and its development application(s) must comply with local laws governing radio spectrum allocation and power limits for this evaluation module. It is the user's sole responsibility to only operate this radio in legally acceptable frequency space and within legally mandated power limitations. Any exceptions to this are strictly prohibited and unauthorized by Texas Instruments unless user has obtained appropriate experimental/development licenses from local regulatory authorities, which is responsibility of user including its acceptable authorization.

For EVMs annotated as FCC – FEDERAL COMMUNICATIONS COMMISSION Part 15 Compliant

Caution

This device complies with part 15 of the FCC Rules. Operation is subject to the following two conditions: (1) This device may not cause harmful interference, and (2) this device must accept any interference received, including interference that may cause undesired operation.

Changes or modifications not expressly approved by the party responsible for compliance could void the user's authority to operate the equipment.

FCC Interference Statement for Class A EVM devices

This equipment has been tested and found to comply with the limits for a Class A digital device, pursuant to part 15 of the FCC Rules. These limits are designed to provide reasonable protection against harmful interference when the equipment is operated in a commercial environment. This equipment generates, uses, and can radiate radio frequency energy and, if not installed and used in accordance with the instruction manual, may cause harmful interference to radio communications. Operation of this equipment in a residential area is likely to cause harmful interference in which case the user will be required to correct the interference at his own expense.

FCC Interference Statement for Class B EVM devices

This equipment has been tested and found to comply with the limits for a Class B digital device, pursuant to part 15 of the FCC Rules. These limits are designed to provide reasonable protection against harmful interference in a residential installation. This equipment generates, uses and can radiate radio frequency energy and, if not installed and used in accordance with the instructions, may cause harmful interference to radio communications. However, there is no guarantee that interference will not occur in a particular installation. If this equipment does cause harmful interference to radio or television reception, which can be determined by turning the equipment off and on, the user is encouraged to try to correct the interference by one or more of the following measures:

- Reorient or relocate the receiving antenna.
- Increase the separation between the equipment and receiver.
- Connect the equipment into an outlet on a circuit different from that to which the receiver is connected.
- Consult the dealer or an experienced radio/TV technician for help.

For EVMs annotated as IC – INDUSTRY CANADA Compliant

This Class A or B digital apparatus complies with Canadian ICES-003.

Changes or modifications not expressly approved by the party responsible for compliance could void the user's authority to operate the equipment.

Concerning EVMs including radio transmitters

This device complies with Industry Canada licence-exempt RSS standard(s). Operation is subject to the following two conditions: (1) this device may not cause interference, and (2) this device must accept any interference, including interference that may cause undesired operation of the device.

Concerning EVMs including detachable antennas

Under Industry Canada regulations, this radio transmitter may only operate using an antenna of a type and maximum (or lesser) gain approved for the transmitter by Industry Canada. To reduce potential radio interference to other users, the antenna type and its gain should be so chosen that the equivalent isotropically radiated power (e.i.r.p.) is not more than that necessary for successful communication.

This radio transmitter has been approved by Industry Canada to operate with the antenna types listed in the user guide with the maximum permissible gain and required antenna impedance for each antenna type indicated. Antenna types not included in this list, having a gain greater than the maximum gain indicated for that type, are strictly prohibited for use with this device.

Cet appareil numérique de la classe A ou B est conforme à la norme NMB-003 du Canada.

Les changements ou les modifications pas expressément approuvés par la partie responsable de la conformité ont pu vider l'autorité de l'utilisateur pour actionner l'équipement.

Concernant les EVMs avec appareils radio

Le présent appareil est conforme aux CNR d'Industrie Canada applicables aux appareils radio exempts de licence. L'exploitation est autorisée aux deux conditions suivantes : (1) l'appareil ne doit pas produire de brouillage, et (2) l'utilisateur de l'appareil doit accepter tout brouillage radioélectrique subi, même si le brouillage est susceptible d'en compromettre le fonctionnement.

Concernant les EVMs avec antennes détachables

Conformément à la réglementation d'Industrie Canada, le présent émetteur radio peut fonctionner avec une antenne d'un type et d'un gain maximal (ou inférieur) approuvé pour l'émetteur par Industrie Canada. Dans le but de réduire les risques de brouillage radioélectrique à l'intention des autres utilisateurs, il faut choisir le type d'antenne et son gain de sorte que la puissance isotrope rayonnée équivalente (p.i.r.e.) ne dépasse pas l'intensité nécessaire à l'établissement d'une communication satisfaisante.

Le présent émetteur radio a été approuvé par Industrie Canada pour fonctionner avec les types d'antenne énumérés dans le manuel d'usage et ayant un gain admissible maximal et l'impédance requise pour chaque type d'antenne. Les types d'antenne non inclus dans cette liste, ou dont le gain est supérieur au gain maximal indiqué, sont strictement interdits pour l'exploitation de l'émetteur.

【Important Notice for Users of this Product in Japan】

This development kit is NOT certified as Confirming to Technical Regulations of Radio Law of Japan

If you use this product in Japan, you are required by Radio Law of Japan to follow the instructions below with respect to this product:

1. Use this product in a shielded room or any other test facility as defined in the notification #173 issued by Ministry of Internal Affairs and Communications on March 28, 2006, based on Sub-section 1.1 of Article 6 of the Ministry's Rule for Enforcement of Radio Law of Japan,
2. Use this product only after you obtained the license of Test Radio Station as provided in Radio Law of Japan with respect to this product, or
3. Use of this product only after you obtained the Technical Regulations Conformity Certification as provided in Radio Law of Japan with respect to this product. Also, please do not transfer this product, unless you give the same notice above to the transferee. Please note that if you could not follow the instructions above, you will be subject to penalties of Radio Law of Japan.

Texas Instruments Japan Limited
(address) 24-1, Nishi-Shinjuku 6 chome, Shinjuku-ku, Tokyo, Japan

<http://www.tij.co.jp>

【ご使用にあたっての注】

本開発キットは技術基準適合証明を受けておりません。

本製品のご使用に際しては、電波法遵守のため、以下のいずれかの措置を取っていただく必要がありますのでご注意ください。

1. 電波法施行規則第6条第1項第1号に基づく平成18年3月28日総務省告示第173号で定められた電波暗室等の試験設備でご使用いただく。
2. 実験局の免許を取得後ご使用いただく。
3. 技術基準適合証明を取得後ご使用いただく。

なお、本製品は、上記の「ご使用にあたっての注意」を譲渡先、移転先に通知しない限り、譲渡、移転できないものとします。

上記を遵守頂けない場合は、電波法の罰則が適用される可能性があることをご留意ください。

日本テキサス・インスツルメンツ株式会社
東京都新宿区西新宿6丁目24番1号
西新宿三井ビル

<http://www.tij.co.jp>

EVALUATION BOARD/KIT/MODULE (EVM) WARNINGS, RESTRICTIONS AND DISCLAIMERS

For Feasibility Evaluation Only, in Laboratory/Development Environments. Unless otherwise indicated, this EVM is not a finished electrical equipment and not intended for consumer use. It is intended solely for use for preliminary feasibility evaluation in laboratory/development environments by technically qualified electronics experts who are familiar with the dangers and application risks associated with handling electrical mechanical components, systems and subsystems. It should not be used as all or part of a finished end product.

Your Sole Responsibility and Risk. You acknowledge, represent and agree that:

1. You have unique knowledge concerning Federal, State and local regulatory requirements (including but not limited to Food and Drug Administration regulations, if applicable) which relate to your products and which relate to your use (and/or that of your employees, affiliates, contractors or designees) of the EVM for evaluation, testing and other purposes.
2. You have full and exclusive responsibility to assure the safety and compliance of your products with all such laws and other applicable regulatory requirements, and also to assure the safety of any activities to be conducted by you and/or your employees, affiliates, contractors or designees, using the EVM. Further, you are responsible to assure that any interfaces (electronic and/or mechanical) between the EVM and any human body are designed with suitable isolation and means to safely limit accessible leakage currents to minimize the risk of electrical shock hazard.
3. You will employ reasonable safeguards to ensure that your use of the EVM will not result in any property damage, injury or death, even if the EVM should fail to perform as described or expected.
4. You will take care of proper disposal and recycling of the EVM's electronic components and packing materials.

Certain Instructions. It is important to operate this EVM within TI's recommended specifications and environmental considerations per the user guidelines. Exceeding the specified EVM ratings (including but not limited to input and output voltage, current, power, and environmental ranges) may cause property damage, personal injury or death. If there are questions concerning these ratings please contact a TI field representative prior to connecting interface electronics including input power and intended loads. Any loads applied outside of the specified output range may result in unintended and/or inaccurate operation and/or possible permanent damage to the EVM and/or interface electronics. Please consult the EVM User's Guide prior to connecting any load to the EVM output. If there is uncertainty as to the load specification, please contact a TI field representative. During normal operation, some circuit components may have case temperatures greater than 60°C as long as the input and output are maintained at a normal ambient operating temperature. These components include but are not limited to linear regulators, switching transistors, pass transistors, and current sense resistors which can be identified using the EVM schematic located in the EVM User's Guide. When placing measurement probes near these devices during normal operation, please be aware that these devices may be very warm to the touch. As with all electronic evaluation tools, only qualified personnel knowledgeable in electronic measurement and diagnostics normally found in development environments should use these EVMs.

Agreement to Defend, Indemnify and Hold Harmless. You agree to defend, indemnify and hold TI, its licensors and their representatives harmless from and against any and all claims, damages, losses, expenses, costs and liabilities (collectively, "Claims") arising out of or in connection with any use of the EVM that is not in accordance with the terms of the agreement. This obligation shall apply whether Claims arise under law of tort or contract or any other legal theory, and even if the EVM fails to perform as described or expected.

Safety-Critical or Life-Critical Applications. If you intend to evaluate the components for possible use in safety critical applications (such as life support) where a failure of the TI product would reasonably be expected to cause severe personal injury or death, such as devices which are classified as FDA Class III or similar classification, then you must specifically notify TI of such intent and enter into a separate Assurance and Indemnity Agreement.

Mailing Address: Texas Instruments, Post Office Box 655303, Dallas, Texas 75265
Copyright © 2012, Texas Instruments Incorporated

IMPORTANT NOTICE

Texas Instruments Incorporated and its subsidiaries (TI) reserve the right to make corrections, enhancements, improvements and other changes to its semiconductor products and services per JESD46, latest issue, and to discontinue any product or service per JESD48, latest issue. Buyers should obtain the latest relevant information before placing orders and should verify that such information is current and complete. All semiconductor products (also referred to herein as "components") are sold subject to TI's terms and conditions of sale supplied at the time of order acknowledgment.

TI warrants performance of its components to the specifications applicable at the time of sale, in accordance with the warranty in TI's terms and conditions of sale of semiconductor products. Testing and other quality control techniques are used to the extent TI deems necessary to support this warranty. Except where mandated by applicable law, testing of all parameters of each component is not necessarily performed.

TI assumes no liability for applications assistance or the design of Buyers' products. Buyers are responsible for their products and applications using TI components. To minimize the risks associated with Buyers' products and applications, Buyers should provide adequate design and operating safeguards.

TI does not warrant or represent that any license, either express or implied, is granted under any patent right, copyright, mask work right, or other intellectual property right relating to any combination, machine, or process in which TI components or services are used. Information published by TI regarding third-party products or services does not constitute a license to use such products or services or a warranty or endorsement thereof. Use of such information may require a license from a third party under the patents or other intellectual property of the third party, or a license from TI under the patents or other intellectual property of TI.

Reproduction of significant portions of TI information in TI data books or data sheets is permissible only if reproduction is without alteration and is accompanied by all associated warranties, conditions, limitations, and notices. TI is not responsible or liable for such altered documentation. Information of third parties may be subject to additional restrictions.

Resale of TI components or services with statements different from or beyond the parameters stated by TI for that component or service voids all express and any implied warranties for the associated TI component or service and is an unfair and deceptive business practice. TI is not responsible or liable for any such statements.

Buyer acknowledges and agrees that it is solely responsible for compliance with all legal, regulatory and safety-related requirements concerning its products, and any use of TI components in its applications, notwithstanding any applications-related information or support that may be provided by TI. Buyer represents and agrees that it has all the necessary expertise to create and implement safeguards which anticipate dangerous consequences of failures, monitor failures and their consequences, lessen the likelihood of failures that might cause harm and take appropriate remedial actions. Buyer will fully indemnify TI and its representatives against any damages arising out of the use of any TI components in safety-critical applications.

In some cases, TI components may be promoted specifically to facilitate safety-related applications. With such components, TI's goal is to help enable customers to design and create their own end-product solutions that meet applicable functional safety standards and requirements. Nonetheless, such components are subject to these terms.

No TI components are authorized for use in FDA Class III (or similar life-critical medical equipment) unless authorized officers of the parties have executed a special agreement specifically governing such use.

Only those TI components which TI has specifically designated as military grade or "enhanced plastic" are designed and intended for use in military/aerospace applications or environments. Buyer acknowledges and agrees that any military or aerospace use of TI components which have **not** been so designated is solely at the Buyer's risk, and that Buyer is solely responsible for compliance with all legal and regulatory requirements in connection with such use.

TI has specifically designated certain components which meet ISO/TS16949 requirements, mainly for automotive use. Components which have not been so designated are neither designed nor intended for automotive use; and TI will not be responsible for any failure of such components to meet such requirements.

Products

| | |
|------------------------------|--|
| Audio | www.ti.com/audio |
| Amplifiers | amplifier.ti.com |
| Data Converters | dataconverter.ti.com |
| DLP® Products | www.dlp.com |
| DSP | dsp.ti.com |
| Clocks and Timers | www.ti.com/clocks |
| Interface | interface.ti.com |
| Logic | logic.ti.com |
| Power Mgmt | power.ti.com |
| Microcontrollers | microcontroller.ti.com |
| RFID | www.ti-rfid.com |
| OMAP Applications Processors | www.ti.com/omap |
| Wireless Connectivity | www.ti.com/wirelessconnectivity |

Applications

| | |
|-------------------------------|--|
| Automotive and Transportation | www.ti.com/automotive |
| Communications and Telecom | www.ti.com/communications |
| Computers and Peripherals | www.ti.com/computers |
| Consumer Electronics | www.ti.com/consumer-apps |
| Energy and Lighting | www.ti.com/energy |
| Industrial | www.ti.com/industrial |
| Medical | www.ti.com/medical |
| Security | www.ti.com/security |
| Space, Avionics and Defense | www.ti.com/space-avionics-defense |
| Video and Imaging | www.ti.com/video |

TI E2E Community

e2e.ti.com