

NOTES:

1. TERMINAL TO BE USED IN HOUSINGS 70066-**** AND 70450-****
2. REFER TO PRODUCT SPECIFICATION PS-71851
3. REFER TO MOLEX OPERATIONS AND SERVICE MANUAL FOR CRIMP DETAILS
4. TERMINAL TO BE USED WITH (0.64)/.025 SQUARE PINS
5. TERMINAL TO BE USED WITH 24-30 AWG STRANDED WIRE WITH (1.52)/.060 MAX. DIA. INSULATION
6. TERMINALS SUPPLIED IN REEL FORM

PLATING:

.000150 MINIMUM TIN PLATE
OVER NICKEL PLATE.

*THE PRIMARY SHIPPING CARTON WILL BE LABELED "COMPLIANT TO
RoHS DIRECTIVE 2002/95/EC AND ELV ANNEX II OF DIRECTIVE 2000/53/EC".
CARTONS WITHOUT THIS LABEL MAY CONTAIN PRODUCT WITH LEAD.

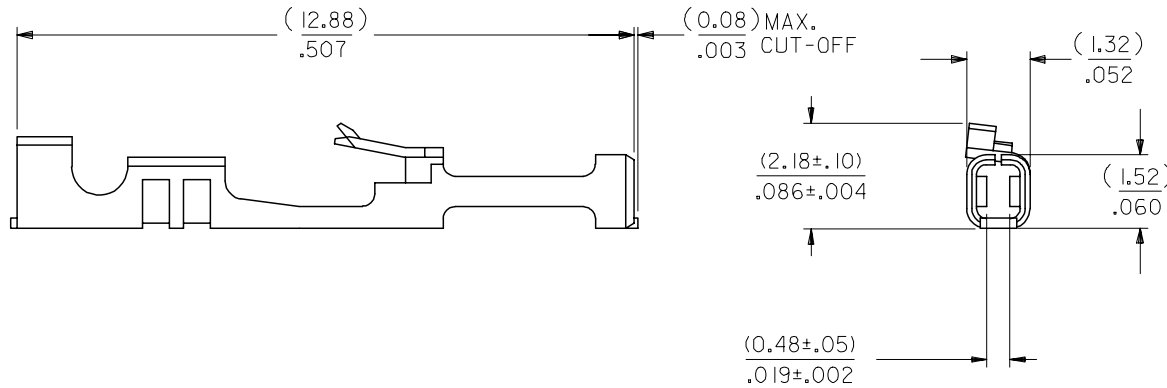
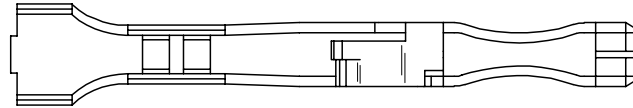

INITIAL RELEASE EC NO: UCP2005-1611 DRWN:MS IBARRA 2005/04/04 CHKD:DMORGAN 2005/04/04 APPR:SMILLER 2005/04/08	DESCRIPTION A	QUALITY SYMBOLS ▽=0 ▽=0	GENERAL TOLERANCES (UNLESS SPECIFIED)		DIMENSION STYLE IN/MM	SCALE 10:1	DESIGN UNITS INCH	THIRD ANGLE PROJECTION
		4 PLACES ± --- ± ---	mm INCH	DRAWN BY DATE MS IBARRA 05/02/02	TITLE TERMINAL-BOX/CRIMP HIGH FORCE CONTACT			
		3 PLACES ± --- ± .010		CHECKED BY DATE DMORGAN 05/02/02	MOLEX INCORPORATED			
		2 PLACES ± 0.25 ± .014 1 PLACE ± 0.35 ± --- ANGULAR ±1/2°		APPROVED BY DATE SMILLER 05/02/02	MATERIAL NO. 016-02-1112	DOCUMENT NO. SD-71851-0004	SHEET NO. 1 OF 1	
DRAFT WHERE APPLICABLE MUST REMAIN WITHIN DIMENSIONS			SIZE B	THIS DRAWING CONTAINS INFORMATION THAT IS PROPRIETARY TO MOLEX INCORPORATED AND SHOULD NOT BE USED WITHOUT WRITTEN PERMISSION				