

PART NUMBER	REVISION	DESCRIPTION	FEED TYPE
2266454-2	C	FINE CRIMP HEIGHT ADJUST	PNEUMATIC
7-2266454-2	C	PNEUMATIC AND CRIMP TOOLING KIT	PNEUMATIC
7-2266454-7	B	CRIMP TOOLING KIT	-

ATLANTIC VERSION TERMINATOR INTERFACE ADAPTER

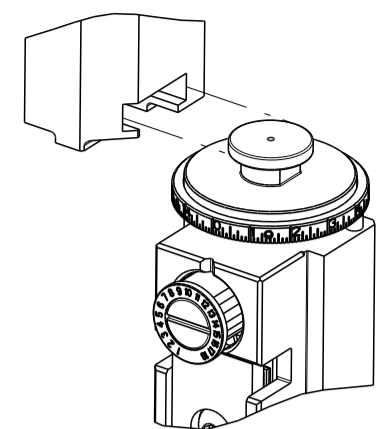

APPLICATOR DATA		
CRIMP	SIZE	TYPE
WIRE	3.94 mm [.155]	F
INSUL	6.00 mm [.236]	F

APPLICATOR INSTRUCTIONS 408-35042

TERMINAL DATA: HIROSE TERMINAL HIROSE CRIMP SPECIFICATION			
TERMINAL NAME: TERMINAL			
WIRE STRIP LENGTH	INSULATION DIAMETER RANGE		
6.50-7.50 mm [.256-.295 IN]	Ø4.04-4.69 mm [.159-.185 IN]		
TERMINAL APPLICATION SPECIFICATION	HIROSE SPEC Rev 2		
TERMINALS APPLIED			
TE TERMINAL	HIROSE TERMINAL	TE TERMINAL	HIROSE TERMINAL
2113561-1	DF60-1012SCFA	2113565-1	DF60-1012PCFA

WIRE SIZE	CRIMP HEIGHT mm [INCH]	CRIMP HEIGHT REFERENCE SETTING
10 AWG	2.63+/-0.05 [1.04+/-0.002]	5.5
12 AWG	2.32+/-0.05 [0.91+/-0.002]	8.6

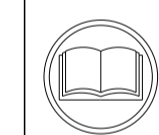

- RECOMMENDED SPARE PARTS
- REFER TO SUPPLIED INSTRUCTION SHEET FOR CLEANING, LUBRICATION AND STORAGE OF APPLICATOR.
- APPLY PART NUMBER 2-23419-6 LOCTITE TO THREADS OF ITEM 242.
- CRIMP HEIGHT REFERENCE SETTING WAS THE SETTING USED WHEN THE APPLICATOR WAS QUALIFIED AT THE FACTORY. ADJUSTMENT MAY BE NECESSARY WHEN RUNNING APPLICATOR IN THE FIELD.
- TERMINAL LUBRICANT IS RECOMMENDED.
- 6. UNLESS SPECIFIED OTHERWISE TORQUE VALUES SHALL BE USED PER DOCUMENT, 101-35000.
- TERMINAL PITCH NOT COMPATIBLE WITH MECHANICAL FEED.

***WARNING**
ON INSTALLATION, SET WIRE DISC TO CRIMP HEIGHT REFERENCE SETTING FOR LARGEST WIRE SIZE. CRIMP HEIGHT REFERENCE SETTINGS GREATER THAN THE VALUE SHOWN MAY CAUSE DAMAGE TO THE CRIMP TOOLING. REFER TO THE INSTRUCTION SHEET FOR PROPER SETUP AND ADJUSTMENTS.

LOC	DIST	REVISIONS					
A	66	P	LTN	DESCRIPTION	DATE	OWN	APVD
		1		DEVELOPMENT	11AUG2014	JH	UG
		A		RELEASED	09OCT2014	JH	TE
		B		ECR-15-017076	23NOV2015	TT	TE
		C		ECR-21-003459	21MAR2021	TB	RK

-	1	1	2119791-5	DEPRESSOR, WIRE	286
-	1	1	2119641-1	FEED CAM, AIR FEED	248
-	1	1	2119082-3	CAM, SNAIL, INSULATION ADJUSTMENT	244
-	1	1	2079764-1	WASHER, WAVE SPRING, CREST-TO-CREST	243
	-	1	2119083-1	RETAINER, INSULATION DIAL	242
-	1	1	7-18023-7	SCR, SKT HD CAP M3 X 4.0	241
-	1	1	2844940-2	AIR FEED MODULE	238
-	REF	REF	994970-2	COUNTER, MAGNETIC	164
	-	1	2119955-1	ASSY, LUBRICATOR, SIDE FEED	113
-	1	1	2844908-1	SCREW, LOCKING	99
-	1	1	2844907-1	POST, LOCKING	98
-	1	1	455888-5	SPACER, CRIMPER	82
-	1	1	1803607-3	DOCUMENTATION PACKAGE	71
-	1	1	2119943-1	WASHER, SPACER	69
-	1	1	2119740-1	TAG, IDENTIFICATION	67
-	2	2	2168078-1	SCREW, DRIVE, RH, RoHS, 2 x .188	66
-	1	1	2168083-2	SCR, SKT HD CAP, RoHS, M4 X 8.0	60
-	1	1	5-18022-5	SCR, HEX HD CAP, M4 X 6.0	59
-	1	1	1338683-8	FEED PAWL	56
-	4	4	2168083-3	SCR, SKT HD CAP, RoHS, M4 X 12.0	54
-	2	2	1-2168083-0	SCR, SKT HD CAP, RoHS, M4 X 10	53
-	1	1	5018030-1	NUT, HEX, REG, RoHS, M3	52
-	1	1	811242-5	BUMPER, HOLD DOWN	51
-	1	1	690753-2	SPACER, TONKER	50
-	1	1	18023-9	SCR, SKT HD CAP M4 X 6.0	49
-	1	1	1803583-9	APPLICATOR BASIC ASSEMBLY, SF	46
-	1	1	1803515-1	RAM ASSEMBLY, SF ATLANTIC	44
-	1	1	1803602-1	SCR, BHSC, RoHS (M8 X 25)	41
-	1	1	1-1752356-9	SUPPORT, TERMINAL	34
-	2	2	2079383-5	SCR, BHSC, RoHS (M4 X 20)	33
-	2	2	3-2844962-3	SPACER, CYLINDRICAL, STRIP GUIDE	30
-	1	1	2844992-1	ASSEMBLY, STRIP GUIDE	29
-	1	1	455888-3	SPACER, CRIMPER	28
-	1	1	1320928-2	STRIP GUIDE	24
-	1	1	2168083-2	SCR, SKT HD CAP, RoHS, M4 X 8.0	21
-	2	2	1-18028-2	WASHER, FLAT, REG M4	20
-	1	1	2119533-1	STRIPPER, SIDE FEED	19
	-	1	2119806-1	INSERT, SHEAR	13
-	1	1	3-22280-3	SPRING, COMPRESSION	12
-	1	1	1-356885-3	STOP, SHEAR	11
	-	1	2119805-1	SHEAR HOLDER, FRONT	10
	-	1	318707-1	FLOATING SHEAR, FRONT	9
	1	2	1803334-7	ANVIL, COMBINATION	8
-	-	-	-	-	7
-	-	-	-	-	6
-	1	1	1-2119757-0	DEPRESSOR, SHEAR	5
-	1	1	2-238011-6	BLOCK, CRIMPER SPACER	4
	1	2	1803327-1	CRIMPER, INSULATION F PREMIUM	3
-	1	1	455888-3	SPACER, CRIMPER	2
	1	2	1803325-7	CRIMPER, WIRE	1

DIMENSIONS:		TOLERANCES UNLESS OTHERWISE SPECIFIED:		MATERIAL:		FINISH:		WEIGHT:		SCALE:	
mm	0 PLC ±	1 PLC ±	2 PLC ±	3 PLC ±	4 PLC ±	ANGLES	FINISH	Customer Accessible Production Drawing	SCALE	1:2	SHEET 1 OF 4

ATLANTIC VERSION
Shown on sheets 1 of 4 & 2 of 4
(Pacific version shown on sheets 3 of 4 & 4 of 4)

LOC	DIST	REVISIONS					
A	66	P	LYN	DESCRIPTION	DATE	DWN	APVD
		-		SEE SHEET 1	-	-	-

FEED TYPE

PNEUMATIC

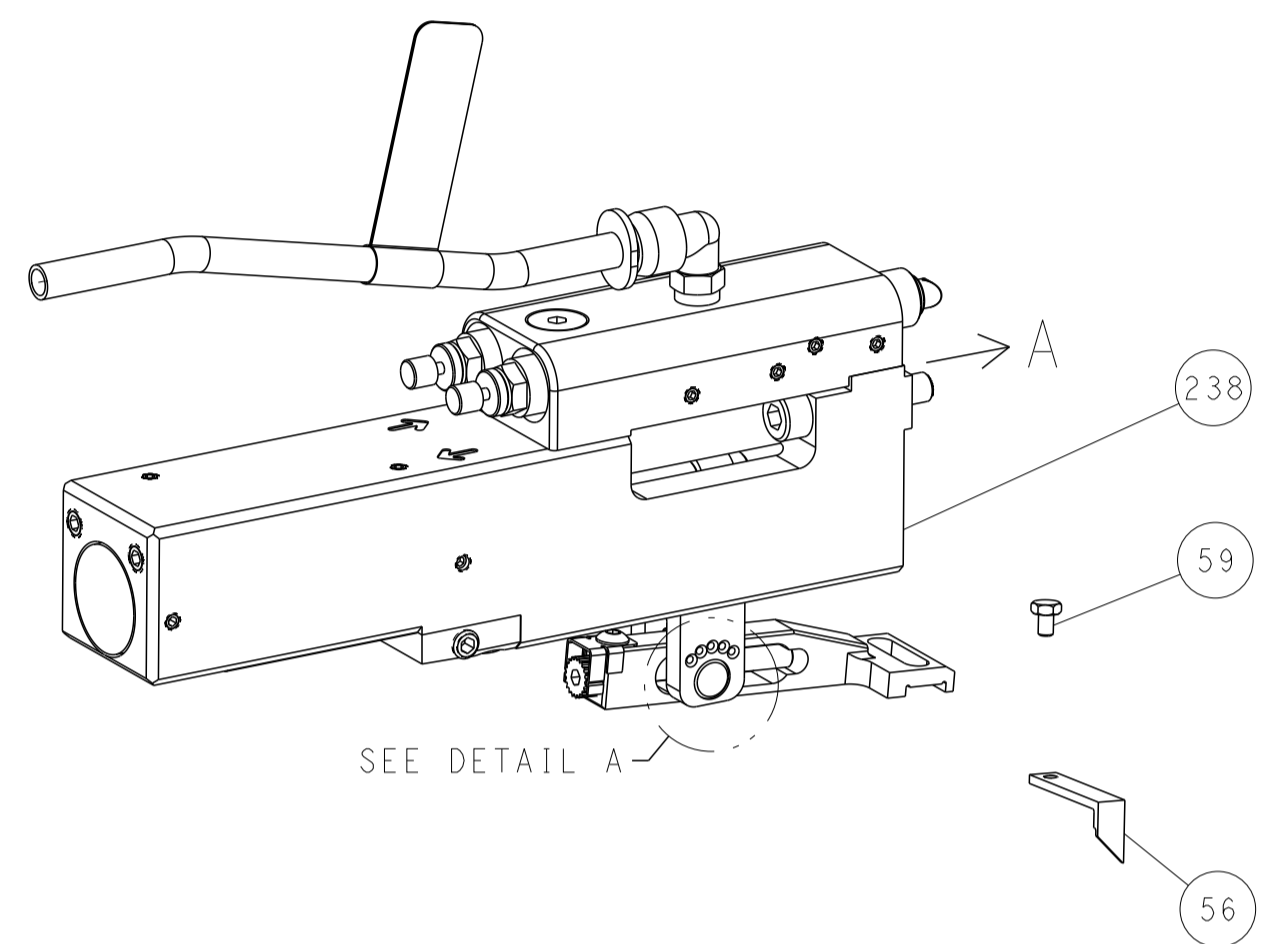

SEE DETAIL A

FEED SPRING SETTING POSITION (SHOWN FROM REAR SIDE)

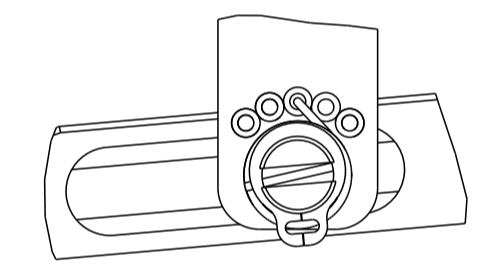

DETAIL A

CAM POSITION

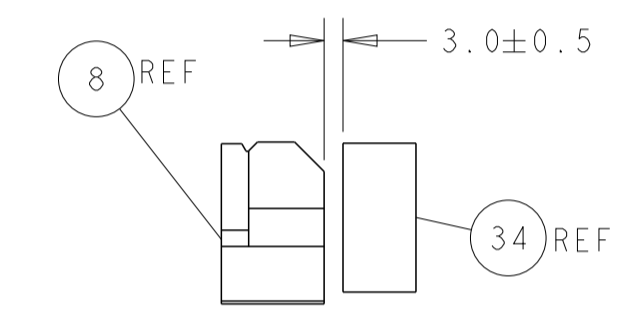
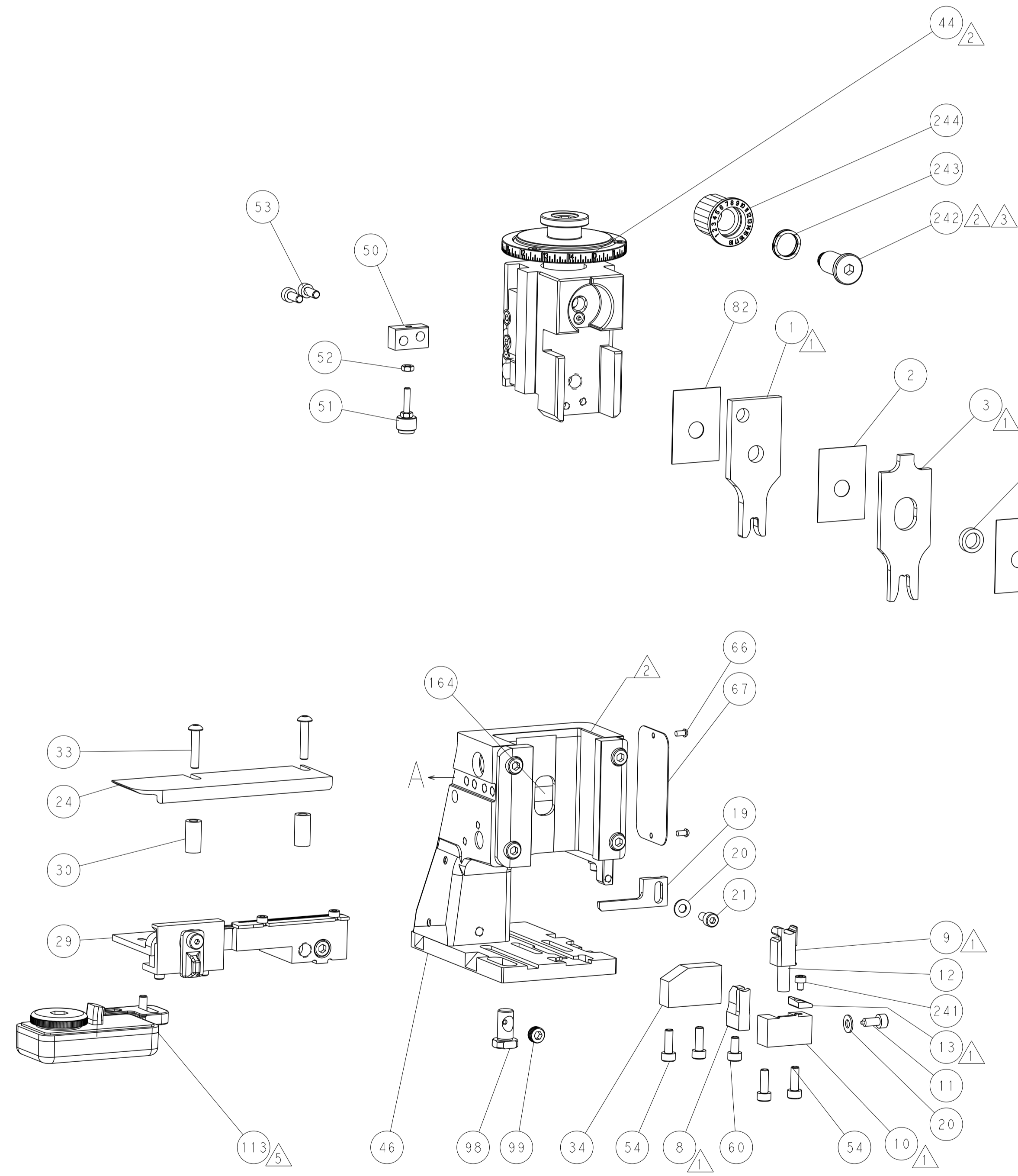
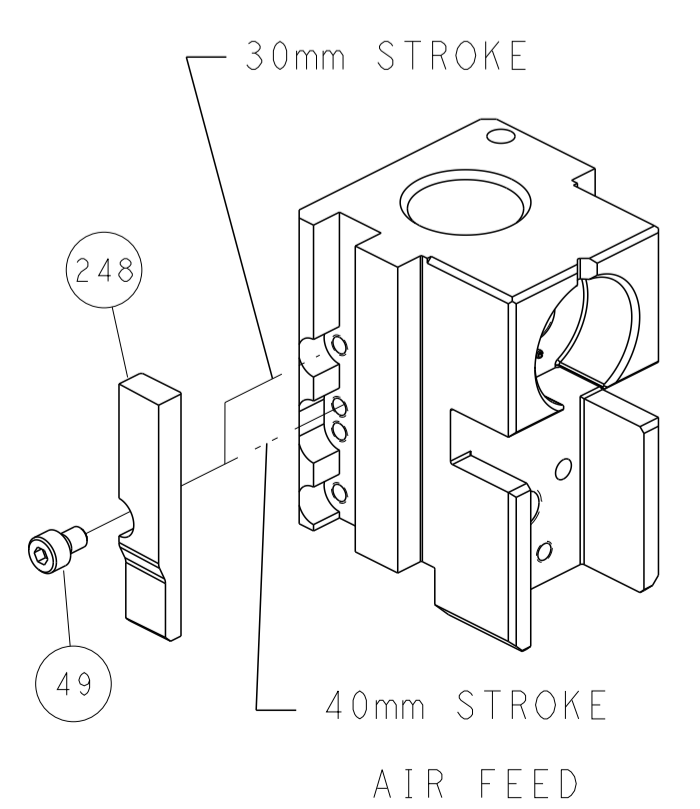

TERMINAL SUPPORT LOCATION

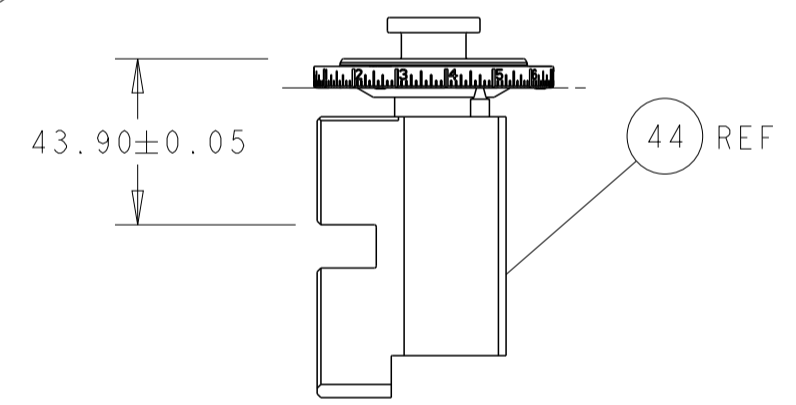

RAM SET-UP

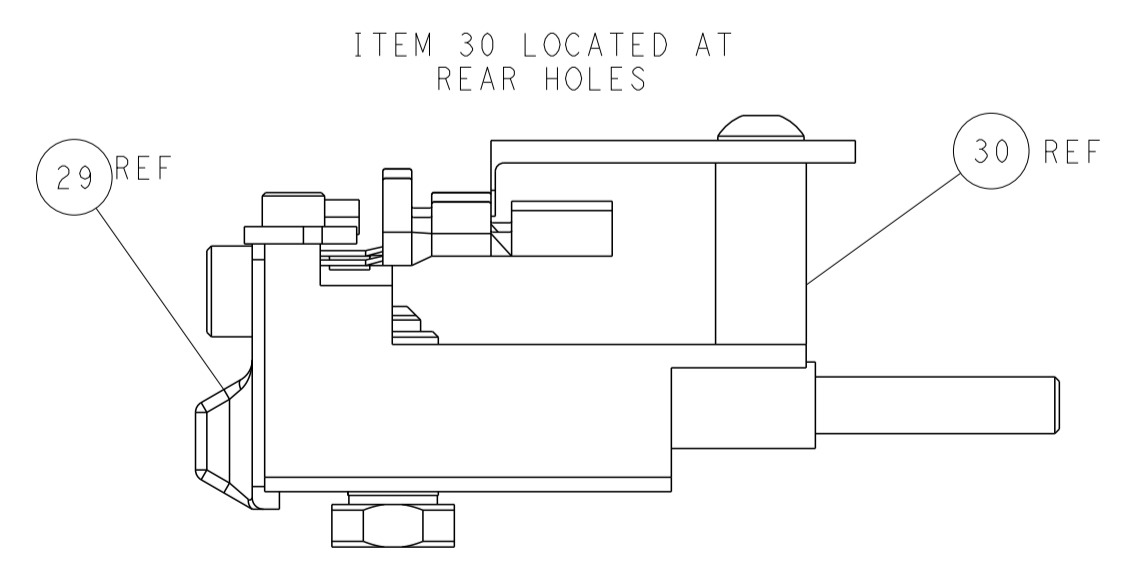

FEED TRACK POSITION GUIDE BY WIRE BARREL

ATLANTIC VERSION
 Shown on sheets 1 of 4 & 2 of 4
 (Pacific version shown on sheets 3 of 4 & 4 of 4)

<small>THIS DRAWING IS UNPUBLISHED. RELEASED FOR PUBLICATION BY TYCO ELECTRONICS CORPORATION. ALL RIGHTS RESERVED.</small>		DWN: J.HOU 8AUGUST2014 CHK: Y.YIN 8AUGUST2014 APVD: H.GUO 8AUGUST2014	NAME: Ocean Side Feed Applicator SIZE: A1 CAGE CODE: 00779 DRAWING NO: 2266454	RESTRICTED TO: - SCALE: 1:2 SHEET: 2 OF 4 REV: C
DIMENSIONS: mm TOLERANCES UNLESS OTHERWISE SPECIFIED: 0 PLC ± 1 PLC ± 2 PLC ± 3 PLC ± 4 PLC ± ANGLES ± FINISH ±	TOLERANCES UNLESS OTHERWISE SPECIFIED: 0 PLC ± 1 PLC ± 2 PLC ± 3 PLC ± 4 PLC ± ANGLES ± FINISH ±	WEIGHT: - MATERIAL: -	CUSTOMER ACCESSIBLE PRODUCTION DRAWING	SHEETS 3 & 4 ARE NOT REQUIRED FOR ATLANTIC VERSION

PART NUMBER	REVISION	DESCRIPTION	FEED TYPE
2-2266454-2	C	FINE CRIMP HEIGHT ADJUST	PNEUMATIC
7-2266454-7	B	CRIMP TOOLING KIT	-

PACIFIC VERSION TERMINATOR
 INTERFACE ADAPTER



APPLICATOR DATA		
CRIMP	SIZE	TYPE
WIRE	3.94 mm [.155]	F
INSUL	6.00 mm [.236]	F

APPLICATOR INSTRUCTIONS
 408-35042

TERMINAL DATA: HIROSE TERMINAL HIROSE CRIMP SPECIFICATION	
TERMINAL NAME: TERMINAL	
WIRE STRIP LENGTH 6.50-7.50 mm [.256-.295 IN]	INSULATION DIAMETER RANGE Ø4.04-4.69 mm [.159-.185 IN]
TERMINAL APPLICATION SPECIFICATION HIROSE SPEC Rev 2	
TERMINALS APPLIED	
TE TERMINAL 2113561-1	HIROSE TERMINAL DF60-1012SCFA
TE TERMINAL 2113565-1	HIROSE TERMINAL DF60-1012PCFA

WIRE SIZE	CRIMP HEIGHT mm [INCH]	CRIMP HEIGHT REFERENCE SETTING
10 AWG	2.63+/-0.05 [.104+/-0.002]	5.5
12 AWG	2.32+/-0.05 [.091+/-0.002]	8.6

***WARNING**
 ON INSTALLATION, SET WIRE DISC TO CRIMP HEIGHT REFERENCE SETTING FOR LARGEST WIRE SIZE. CRIMP HEIGHT REFERENCE SETTINGS GREATER THAN THE VALUE SHOWN MAY CAUSE DAMAGE TO THE CRIMP TOOLING. REFER TO THE INSTRUCTION SHEET FOR PROPER SETUP AND ADJUSTMENTS.

- 1 RECOMMENDED SPARE PARTS
- 2 REFER TO SUPPLIED INSTRUCTION SHEET FOR CLEANING, LUBRICATION AND STORAGE OF APPLICATOR.
- 3 APPLY PART NUMBER 2-23419-6 LOCTITE TO THREADS OF ITEM 242.
- 4 CRIMP HEIGHT REFERENCE SETTING WAS THE SETTING USED WHEN THE APPLICATOR WAS QUALIFIED AT THE FACTORY. ADJUSTMENT MAY BE NECESSARY WHEN RUNNING APPLICATOR IN THE FIELD.
- 5 TERMINAL LUBRICANT IS RECOMMENDED.
- 6 UNLESS SPECIFIED OTHERWISE TORQUE VALUES SHALL BE USED PER DOCUMENT, 101-35000.
- 7 TERMINAL PITCH NOT COMPATIBLE WITH MECHANICAL FEED.

LOC	DIST	REVISIONS					
A	66	P	LTN	DESCRIPTION	DATE	OWN	APVD
-	-	-	-	SEE SHEET 1	-	-	-

-	1	2119791-5	DEPRESSOR, WIRE	286
-	1	2119082-3	CAM, SNAIL, INSULATION ADJUSTMENT	244
-	1	2079764-1	WASHER, WAVE SPRING, CREST-TO-CREST	243
-	1	2119083-1	RETAINER, INSULATION DIAL	242
-	1	7-18023-7	SCR, SKT HD CAP M3 X 4.0	241
-	1	2844940-2	AIR FEED MODULE	238
-	REF	994970-2	COUNTER, MAGNETIC	164
-	1	2119641-2	FEED CAM, AIR FEED	151
-	1	2168083-8	SCR, SKT HD CAP, RoHS, M4 X 16	144
-	4	2168083-9	SCR, SKT HD CAP, RoHS, M4 X 20	143
-	-	2119653-2	FEED CAM, POST FEED	142
-	1	1-1803583-0	APPLICATOR BASIC ASSEMBLY, SF	141
-	1	1803516-1	RAM ASSEMBLY, SF PACIFIC	140
-	1	2119955-1	ASSY, LUBRICATOR, SIDE FEED	113
-	1	2844908-1	SCREW, LOCKING	99
-	1	2844907-1	POST, LOCKING	98
-	1	455888-5	SPACER, CRIMPER	82
-	1	1803607-3	DOCUMENTATION PACKAGE	71
-	1	2119943-1	WASHER, SPACER	69
-	1	2119740-1	TAG, IDENTIFICATION	67
-	2	2168078-1	SCREW, DRIVE, RH, RoHS, 2 x .188	66
-	1	5-18022-5	SCR, HEX HD CAP, M4 X 6.0	59
-	1	1338683-8	FEED PAWL	56
-	2	1-2168083-0	SCR, SKT HD CAP, RoHS, M4 X 10	53
-	1	5018030-1	NUT, HEX, REG, RoHS, M3	52
-	1	811242-5	BUMPER, HOLD DOWN	51
-	1	690753-2	SPACER, TONKER	50
-	1	18023-9	SCR, SKT HD CAP M4 X 6.0	49
-	1	1803602-1	SCR, BHSC, RoHS (M8 X 25)	41
-	1	1-1752356-9	SUPPORT, TERMINAL	34
-	2	2079383-5	SCR, BHSC, RoHS (M4 X 20)	33
-	2	3-2844962-3	SPACER, CYLINDRICAL, STRIP GUIDE	30
-	1	2844992-1	ASSEMBLY, STRIP GUIDE	29
-	1	455888-3	SPACER, CRIMPER	28
-	1	1320928-2	STRIP GUIDE	24
-	1	2168083-2	SCR, SKT HD CAP, RoHS, M4 X 8.0	21
-	2	1-18028-2	WASHER, FLAT, REG M4	20
-	1	2119533-1	STRIPPER, SIDE FEED	19
-	1	2119806-1	INSERT, SHEAR	13
-	1	3-22280-3	SPRING, COMPRESSION	12
-	1	1-356885-3	STOP, SHEAR	11
-	1	2119805-1	SHEAR HOLDER, FRONT	10
-	1	318707-1	FLOATING SHEAR, FRONT	9
-	1	1803334-7	ANVIL, COMBINATION	8
-	-	-	-	7
-	-	-	-	6
-	1	1-2119757-0	DEPRESSOR, SHEAR	5
-	1	2-238011-6	BLOCK, CRIMPER SPACER	4
-	1	1803327-1	CRIMPER, INSULATION F PREMIUM	3
-	1	455888-3	SPACER, CRIMPER	2
-	1	1803325-7	CRIMPER, WIRE	1

DIMENSIONS:		TOLERANCES UNLESS OTHERWISE SPECIFIED:		DWG CHK Y.YIN		8AUGUST2014 8AUGUST2014		TE Connectivity Harrisburg, PA 17105-3608	
mm		0 PLC ± 1 PLC ± 2 PLC ± 3 PLC ± 4 PLC ± ANGLES ± FINISH		APVD U.GUO		8AUGUST2014		NAME Ocean Side Feed Applicator	
MATERIAL		FINISH		APPLICATION SPEC		SIZE A1		CAGE CODE 00779	
				WEIGHT		DRAWING NO C=2266454		RESTRICTED TO	
				SCALE		1:2		SHEET 3 OF 4	

PACIFIC VERSION
 Shown on sheets 3 of 4 & 4 of 4
 (Atlantic version shown on sheets 1 of 4 & 2 of 4)

LOC		DIST		REVISIONS			
A	66	P	LTM	DESCRIPTION	DATE	OWN	APVD
		-		SEE SHEET 1			

FEED TYPE

PNEUMATIC

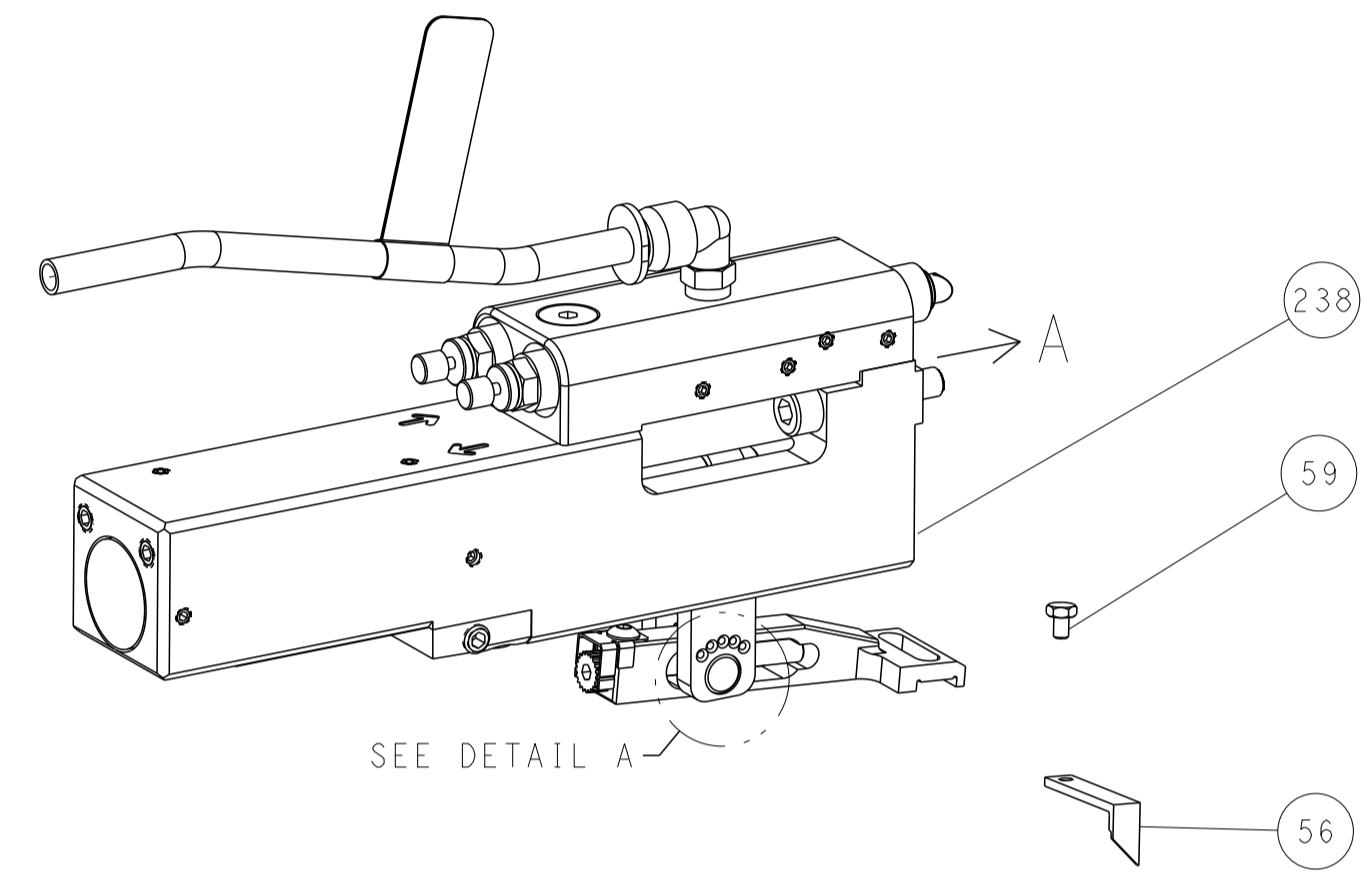

FEED SPRING SETTING POSITION (SHOWN FROM REAR SIDE)

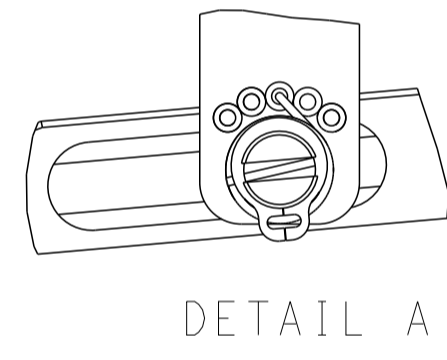

CAM POSITION

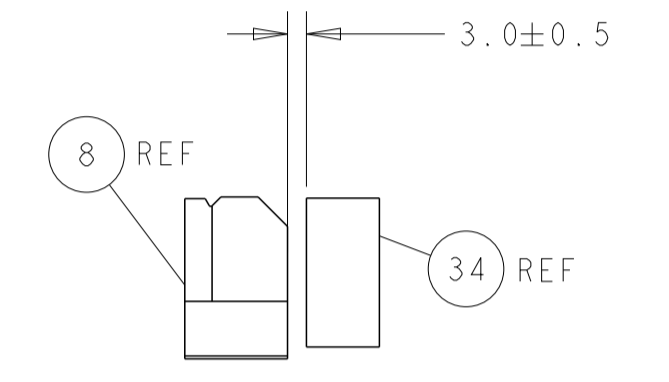
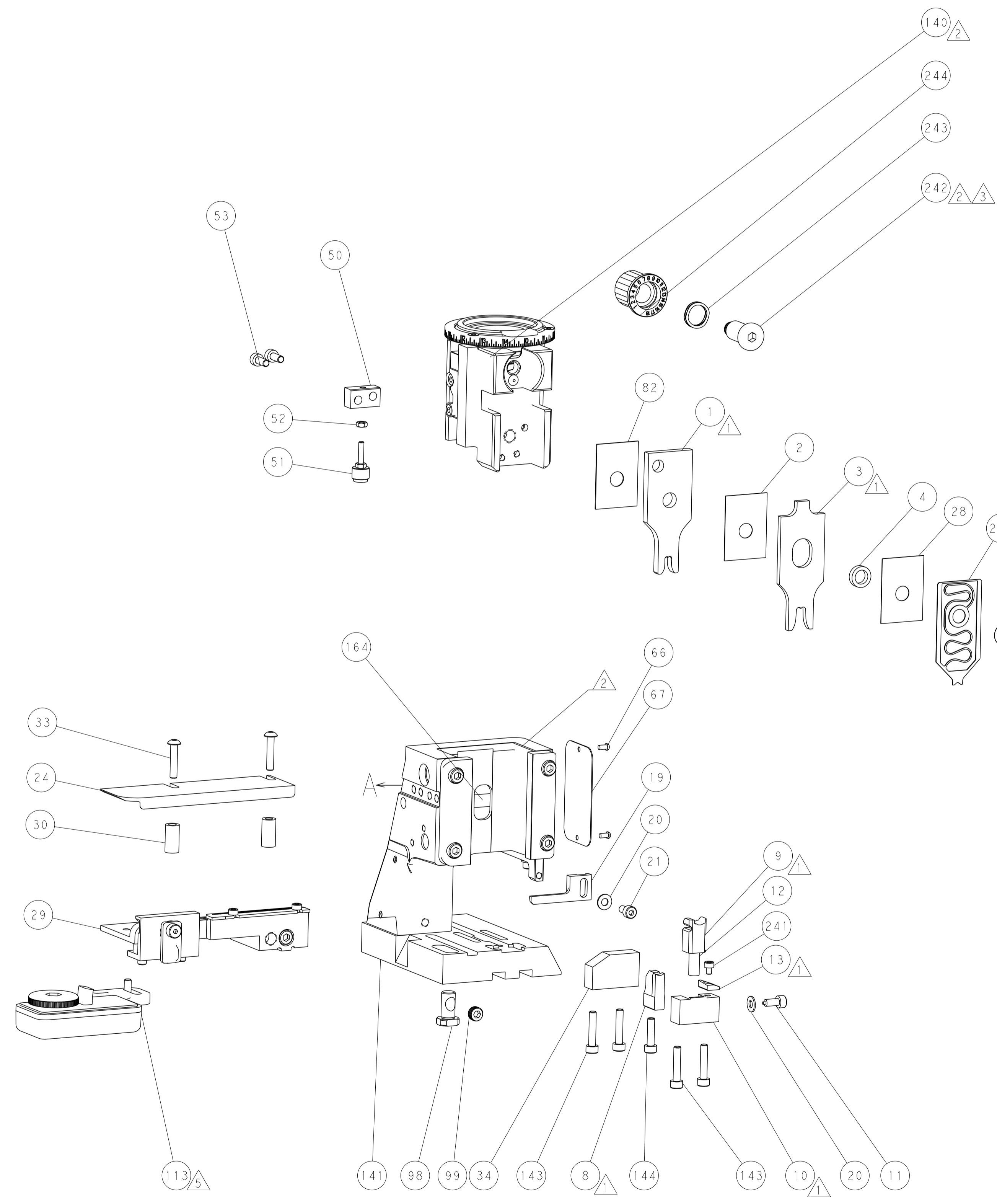
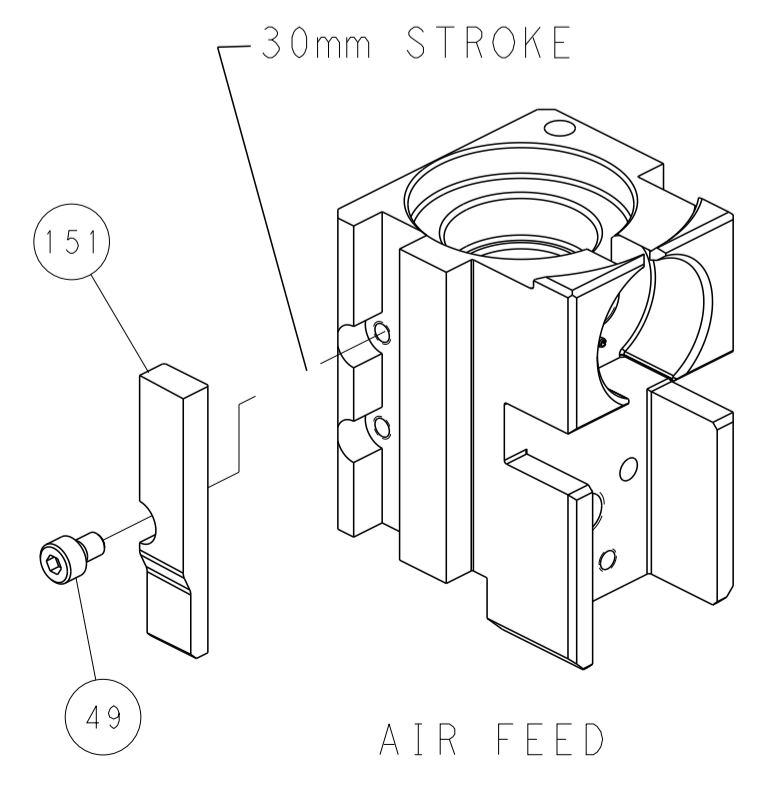

TERMINAL SUPPORT LOCATION

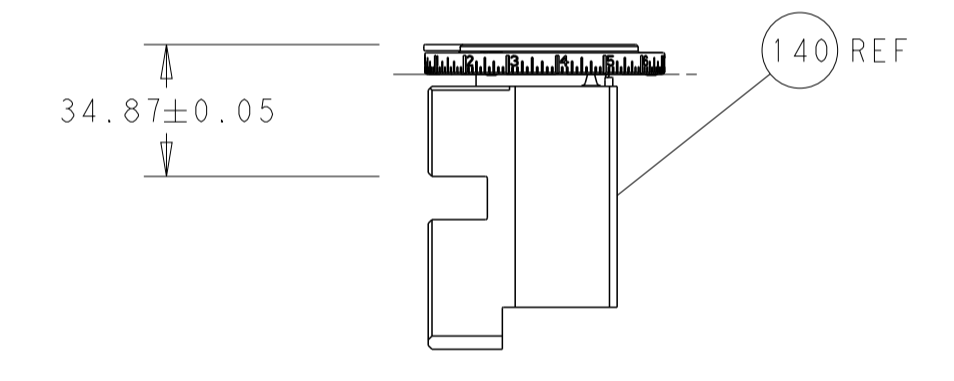

RAM SET-UP

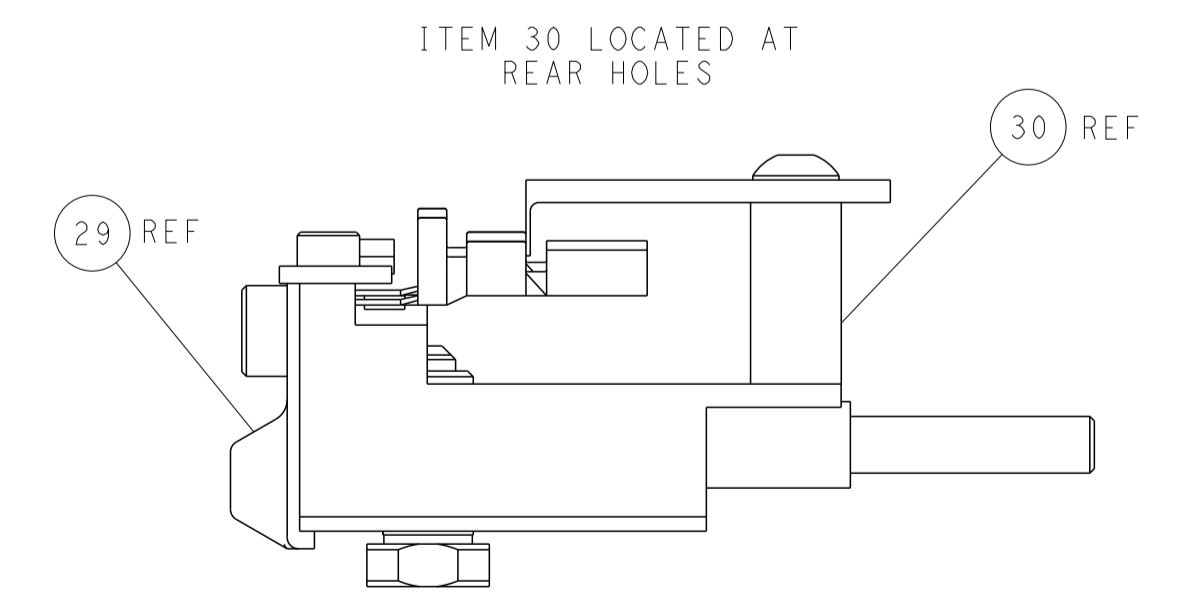

FEED TRACK POSITION GUIDE BY WIRE BARREL

PACIFIC VERSION
 Shown on sheets 3 of 4 & 4 of 4
 (Atlantic version shown on sheets 1 of 4 & 2 of 4)

DIMENSIONS:		TOLERANCES UNLESS OTHERWISE SPECIFIED:		DWG: J.HOU 8AUGUST2014		CHK: Y.YIN 8AUGUST2014		APVD: H.GUO 8AUGUST2014		NAME: Ocean Side Feed Applicator	
mm	0 PLC	±		SIZE	CAGE CODE	DRAWING NO	RESTRICTED TO	STE TE Connectivity Harrisburg, PA 17105-3608			
	1 PLC	±		SCALE	00779	©=2266454		Customer Accessible Production Drawing			
	2 PLC	±		SCALE	1:2			SHEETS 1 & 2 ARE NOT REQUIRED FOR PACIFIC VERSION			
	3 PLC	±		SHEET	4	OF 4	REV	C			
	4 PLC	±									
	ANGLES	±									
MATERIAL	FINISH										