

RC4136

General Performance Quad 741 Operational Amplifier

Features

- Unity gain bandwidth – 3 MHz
- Short circuit protection
- No frequency compensation required
- No latch-up
- Large common mode and differential voltage ranges
- Low power consumption
- Parameter tracking over temperature range
- Gain and phase match between amplifiers

Description

The RC4136 is made up of four 741 type independent high gain operational amplifiers internally compensated and constructed on a single silicon chip using the planar epitaxial process.

This amplifier meets or exceeds all specifications for 741 type amplifiers. Excellent channel separation allows the use

of the RC4136 quad amplifier in all 741 operational amplifier applications providing the highest possible packaging density.

The specially designed low noise input transistors allow the RC4136 to be used in low noise signal processing applications such as audio preamplifiers and signal conditioners.

Block Diagram

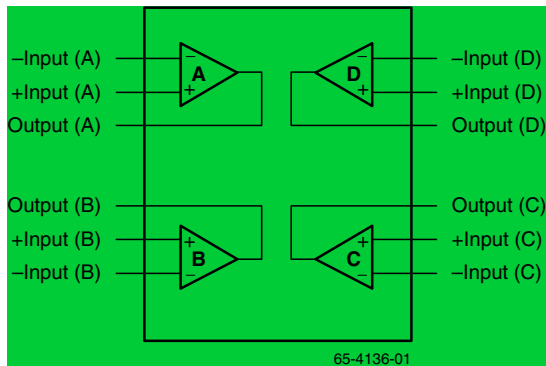

Pin Assignments



Absolute Maximum Ratings

(beyond which the device may be damaged)¹

Parameter		Min	Typ	Max	Units
Supply Voltage	RC4136			±18	V
Input Voltage ²				±30	V
Differential Input Voltage				30	V
Output Short Circuit Duration ³		Indefinite			
PDTA < 50°C	SOIC			300	mW
	PDIP			468	mW
Operating Temperature	RC4136	0		70	°C
Storage Temperature		-65		150	°C
Junction Temperature	SOIC, PDIP			125	°C
Lead Soldering Temperature (60 seconds)	DIP			300	°C
	SOIC			260	°C

Notes:

1. Functional operation under any of these conditions is NOT implied. Performance and reliability are guaranteed only if Operating Conditions are not exceeded.
2. For supply voltages less than ±15V, the absolute maximum input voltage is equal to the supply voltage.
3. Short circuit may be to ground, typically 45 mA.

Operating Conditions

Parameter		Min	Typ	Max	Units
θ _{JC}	Thermal resistance		60		°C/W
θ _{JA}	Thermal resistance	SOIC	200		°C/W
		PDIP	160		°C/W
For T _A > 50°C Derate at			5.0		mW/°C

Electrical Characteristics

($V_S = \pm 15V$ and $T_A = +25^\circ C$, unless otherwise noted)

Parameters	Test Conditions	RC4136			Units
		Min	Typ	Max	
Input Offset Voltage	$R_S \leq 10k\Omega$		0.5	6.0	mV
Input Offset Current			5.0	200	nA
Input Bias Current			40	500	nA
Input Resistance		0.3	5.0		M Ω
Large Signal Voltage Gain	$R_L \geq 2k\Omega$, $V_{OUT} = \pm 10V$	20	300		V/mV
Output Voltage Swing	$R_L \geq 10k\Omega$	± 12	± 14		V
	$R_L \geq 2k\Omega$	± 10	± 13		
Input Voltage Range		± 12	± 14		V
Common Mode Rejection Ratio	$R_S \leq 10k\Omega$	70	100		dB
Power Supply Rejection Ratio	$R_S \leq 10k\Omega$	76	100		dB
Power Consumption	$R_L = \infty$, All Outputs		210	340	mW
Transient Response					
Rise Time	$V_{IN} = 20mV$, $R_L = 2k\Omega$		0.13		μS
Overshoot	$C_L \leq 100pF$		5.0		%
Unity Gain Bandwidth			3.0		MHz
Slew Rate	$R_L \geq 2k\Omega$		1.0		V/ μS
Channel Separation	$F = 1.0kHz$, $R_S = 1k\Omega$		90		dB

Electrical Characteristics

($R_C = 0^\circ C \leq T_A \leq 70^\circ$, $V_S = \pm 15V$)

Parameters	Test Conditions	RC4136			Units
		Min	Typ	Max	
Input Offset Voltage	$R_S \leq 10k\Omega$			7.5	mV
Input Offset Current				300	nA
Input Bias Current				800	nA
Large Signal Voltage Gain	$R_L \geq 2k\Omega$, $V_{OUT} = \pm 10V$	15			V/mV
Output Voltage Swing	$R_L \geq 2k\Omega$	± 10			V
Power Consumption			240	400	mW

Electrical Characteristics Comparison

($V_S = \pm 15V$ and $T_A +25^\circ C$ unless otherwise noted)

Parameter	RC4136 (Typ.)	RC741 (Typ.)	LM324 (Typ.)	Units
Input Offset Voltage	0.5	2.0	2.0	mV
Input Offset Current	5.0	10	5.0	nA
Input Bias Current	40	80	55	nA
Input Resistance	5.0	2.0		M Ω
Large Signal Voltage Gain ($R_L = 2k\Omega$)	300	200	100	V/mV
Output Voltage Swing ($R_L = 2k\Omega$)	$\pm 13V$	$\pm 13V$	$ +V_S - 1.2V $ to $-V_S$	V
Input Voltage Range	$\pm 14V$	$\pm 13V$	$ +V_S - 1.5V $ to $-V_S$	V
Common Mode Rejection Ratio	100	90	85	dB
Power Supply Rejection Ratio	100	90	100	dB
Transient Response				
Rise Time	0.13	0.3		μS
Overshoot	5.0	5.0		%
Unity Gain Bandwidth	3.0	0.8	0.8	MHz
Slew Rate	1.0	0.5	0.5	V/ μS
Input Noise Voltage Density (F= 1kHz)	10	22.5		nV/ \sqrt{Hz}
Short Circuit Current	± 45	± 25		mA

Typical Performance Characteristics

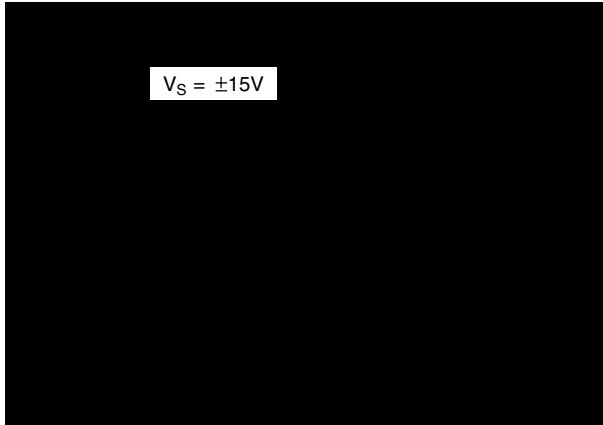

Figure 1. Input Bias Current vs. Temperature

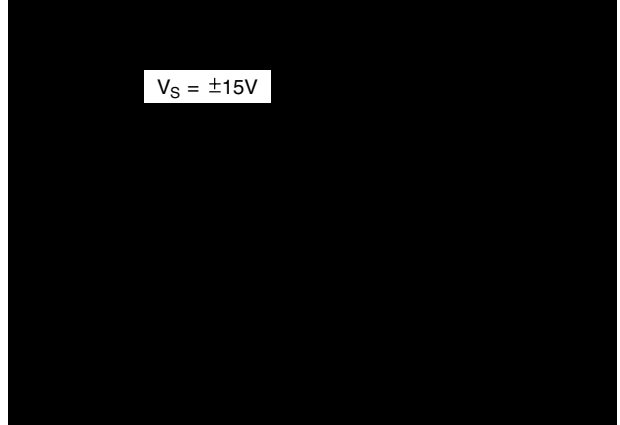

Figure 2. Input Offset Current vs. Temperature

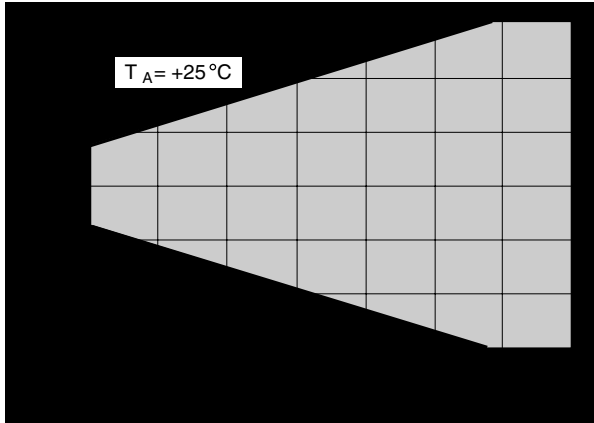

Figure 3. Input Common Mode Voltage Range vs. Supply Voltage

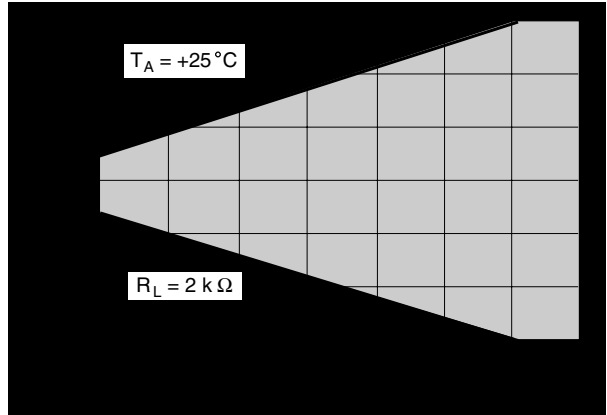

Figure 4. Output Voltage vs. Supply Voltage

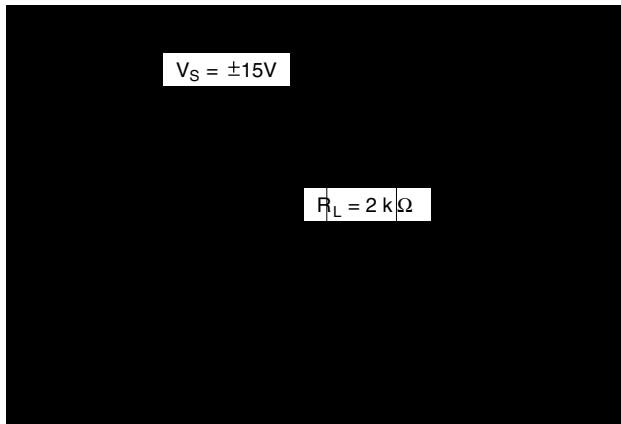

Figure 5. Open Loop Gain vs. Temperature

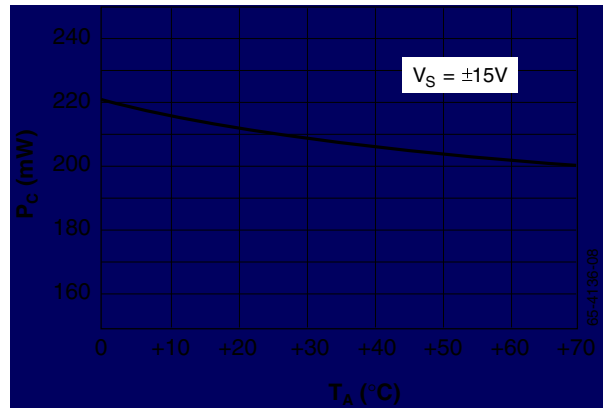

Figure 6. Power Consumption vs. Temperature

Typical Performance Characteristics (continued)

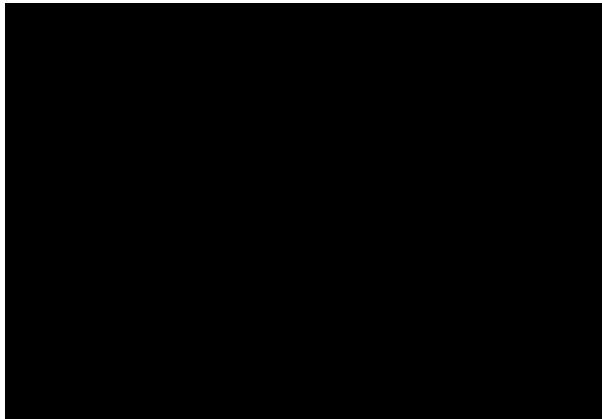

Figure 7. Open Loop Gain vs. Frequency

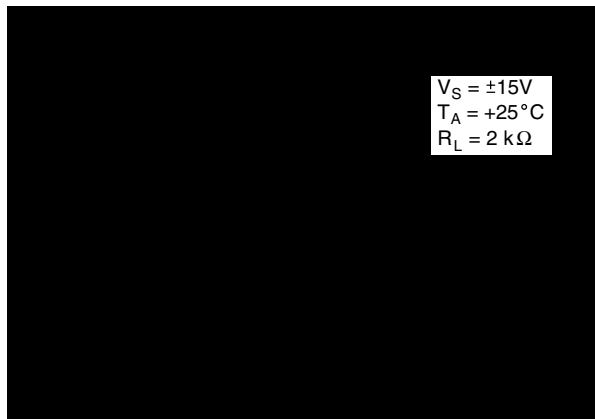

Figure 8. Output Voltage Swing vs. Frequency

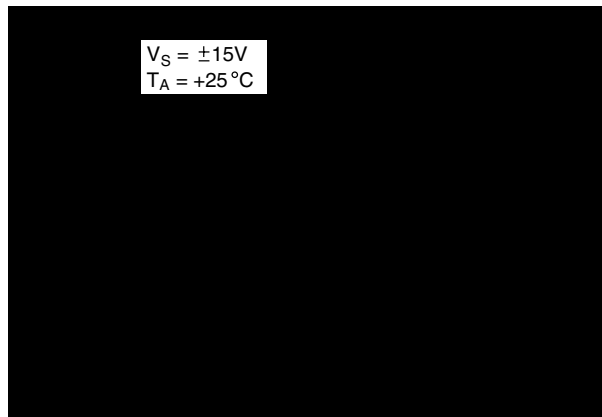

Figure 9. Output Voltage Swing vs. Load Resistance

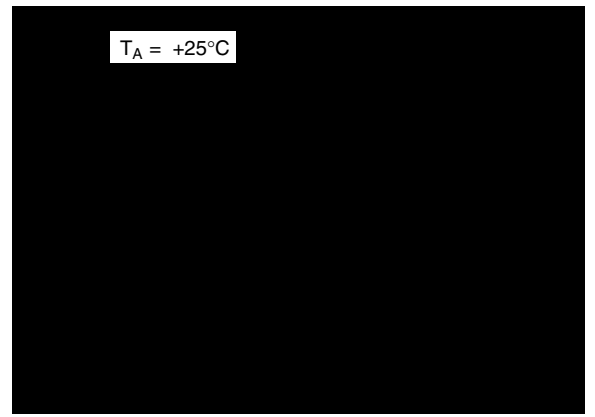

Figure 10. Quiescent Current vs. Supply Voltage

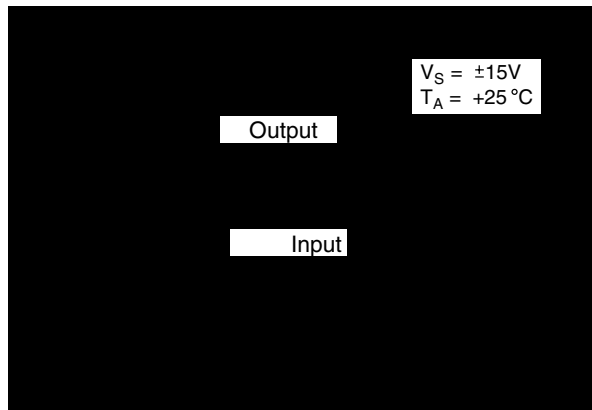

Figure 11. Follower Large Signal Pulse Response

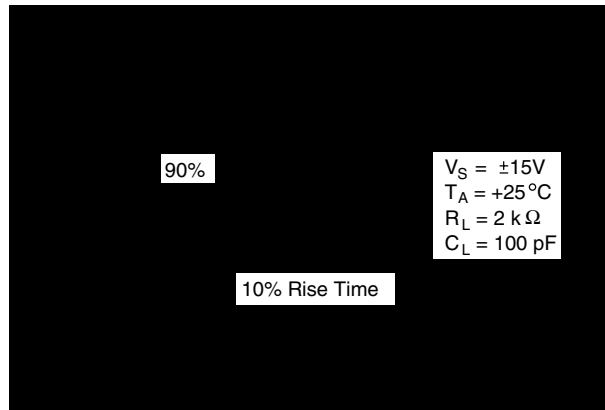

Figure 12. Transient Response Output Voltage vs. Time

Typical Performance Characteristics (continued)

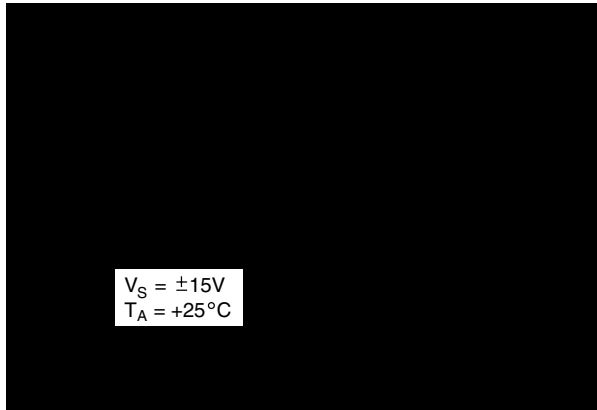

Figure 13. Channel Separation vs. Frequency

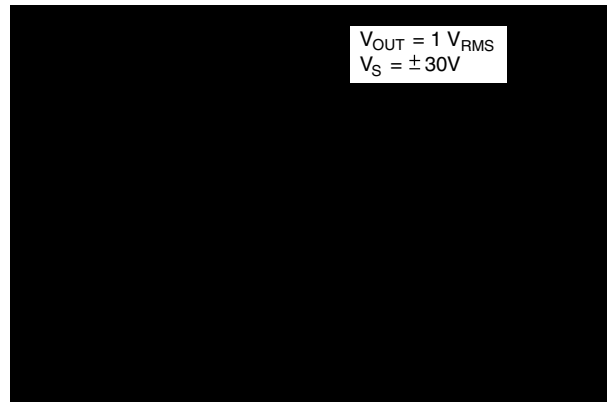

Figure 14. Total Harmonic Distortion vs. Frequency

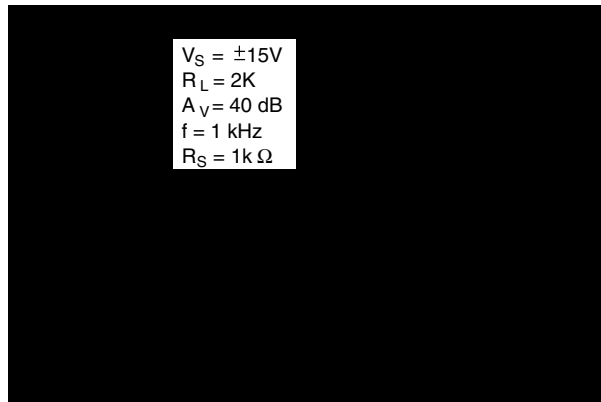

Figure 15. Total Harmonic Distortion vs. Output Voltage

RC4136 Versus LM324

Although the LM324 is an excellent device for single-supply applications where ground sensing is important, it is a poor substitute for four 741s in split supply circuits. The simplified input circuit of the RC4136 exhibits much lower noise

than that of the LM324 and exhibits no crossover distortion as compared with the LM324 (see Figure 16). The LM324 shows significant crossover distortion and pulse delay in attempting to handle a large signal input pulse.

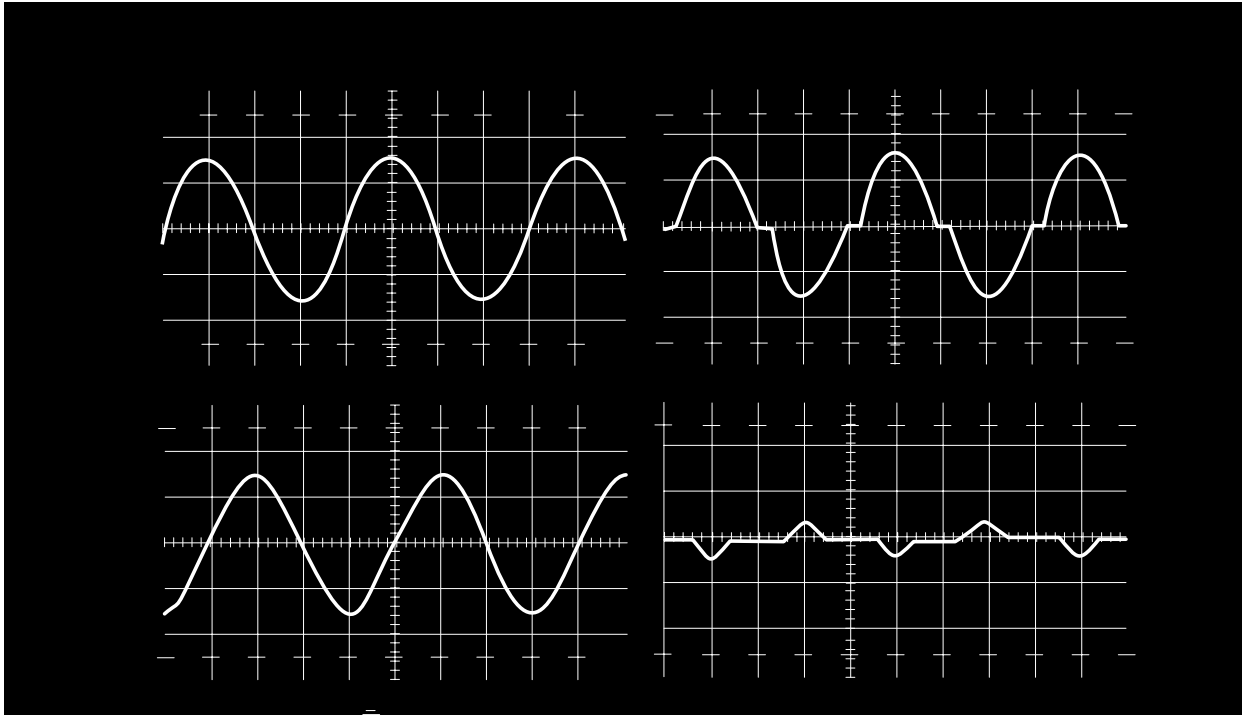

Figure 16. Comparative Crossover Distortion

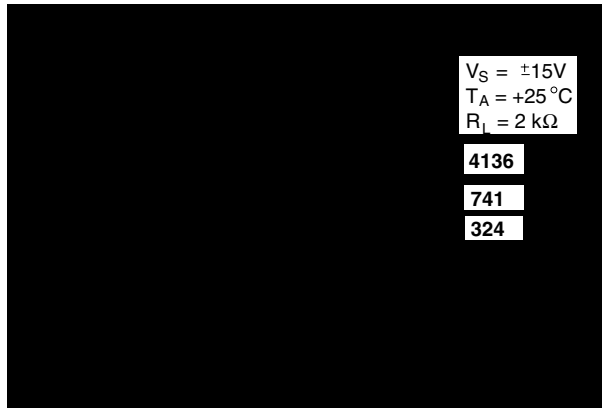

Figure 17. Output Voltage Swing vs. Frequency

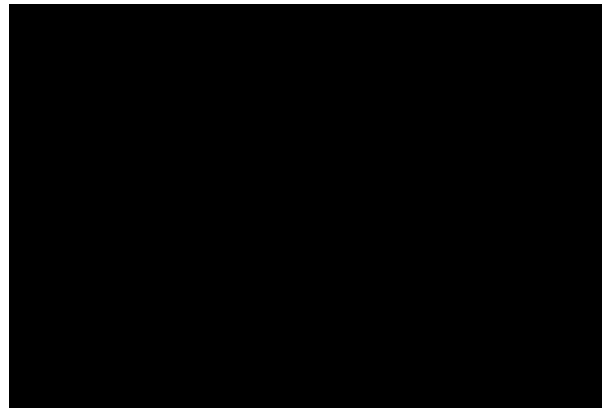

Figure 18. Open Loop Gain vs. Frequency

RC4136 Versus LM324 (continued)

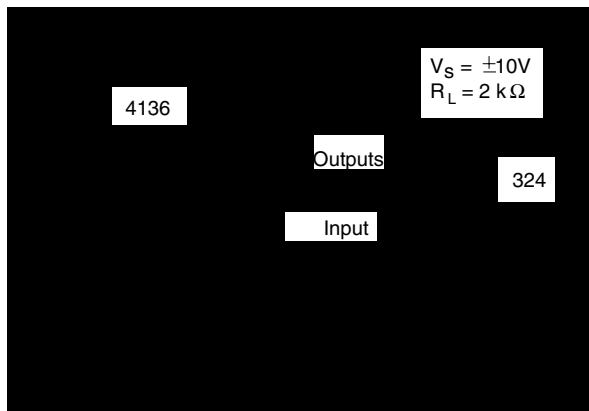

Figure 19. Follower Large Signal Pulse Response Output Voltage vs. Time

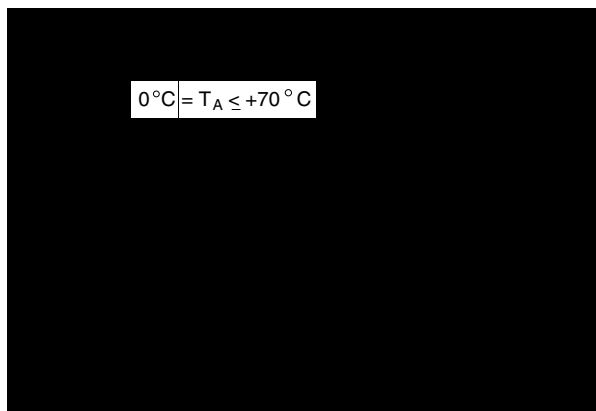

Figure 20. Input Common Mode Voltage Range vs. Supply Voltage

Typical Applications

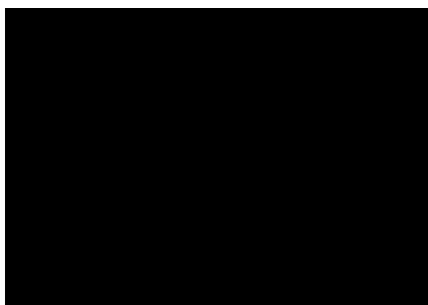

Figure 21. Lamp Driver

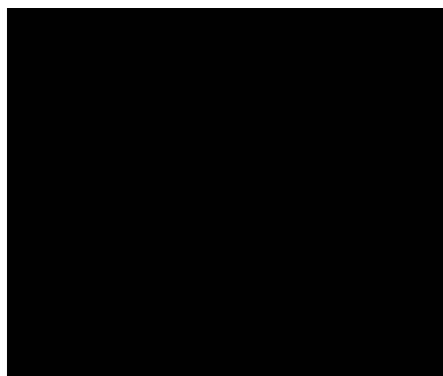

Figure 22. Power Amplifier



Figure 23. Voltage Follower

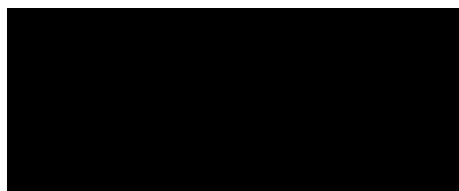

Figure 24. Comparator with Hysteresis

Typical Applications (continued)

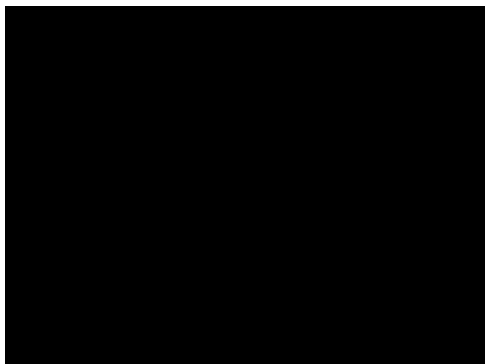

Figure 25. DC Coupled 1kHz Lowpass Active Filter

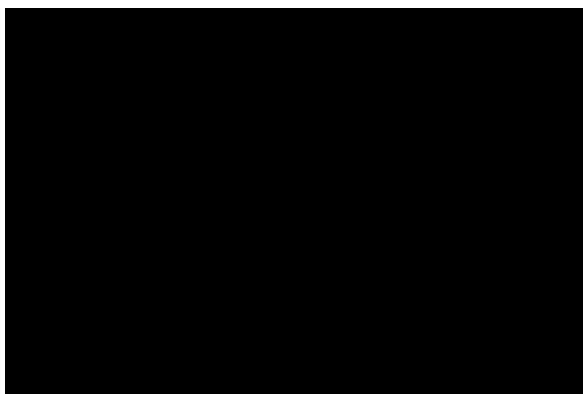

Figure 26. Squarewave Oscillator

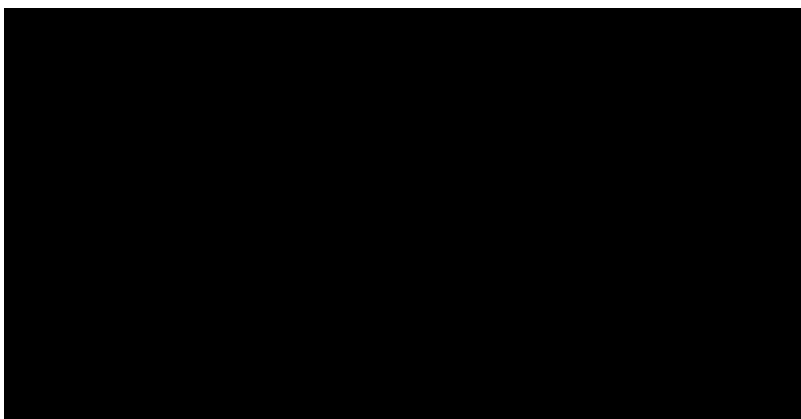

Figure 27. 1kHz Bandpass Active Filter

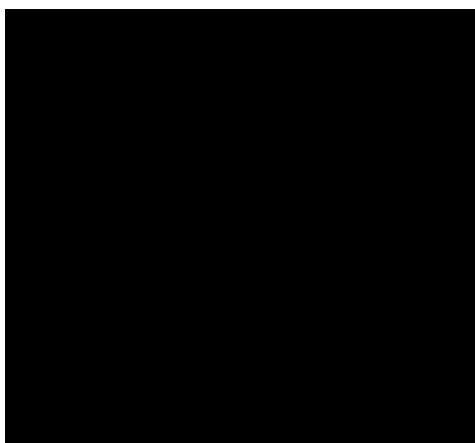

Figure 28. AC Coupled Non-Inverting Amplifier

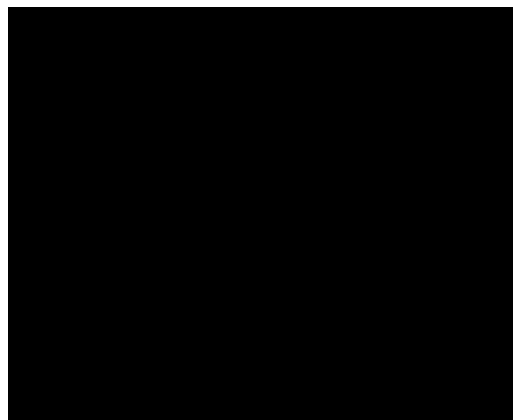

Figure 29. AC Coupled Inverting Amplifier

Typical Applications (continued)

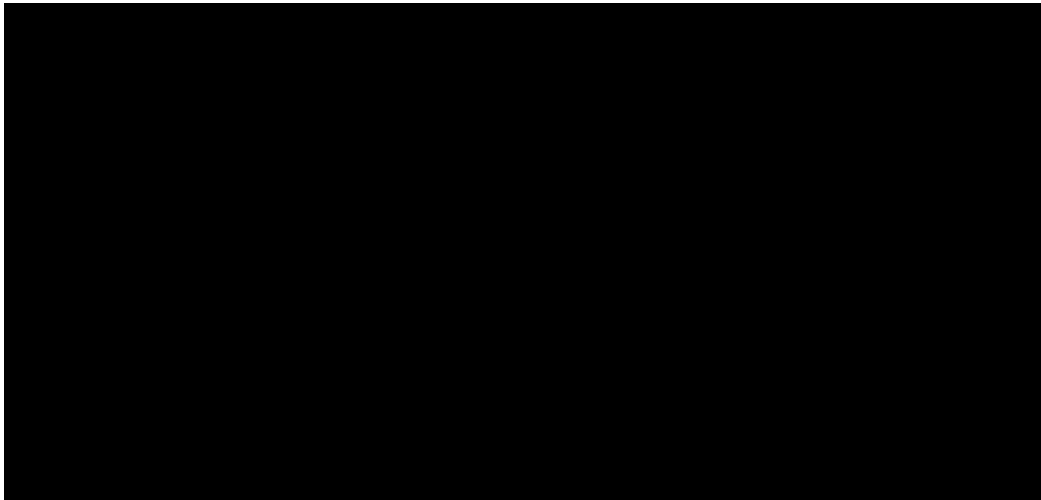

Figure 30. Voltage Control Oscillator (VCO)

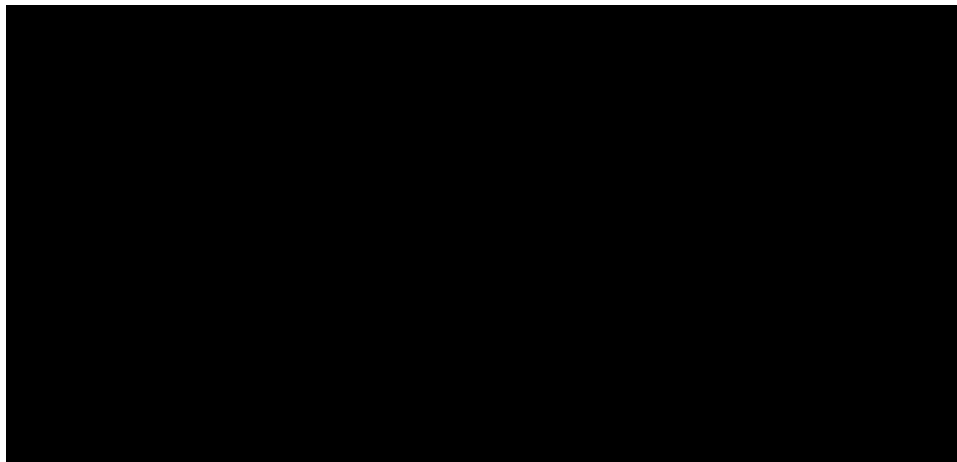

Figure 31. Full-Wave Rectifier and Averaging Filter

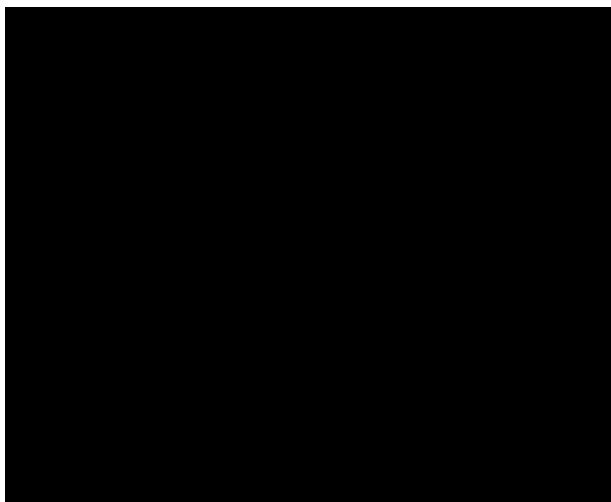

Figure 32. Notch Filter Using the RC4136 as a Gyrator

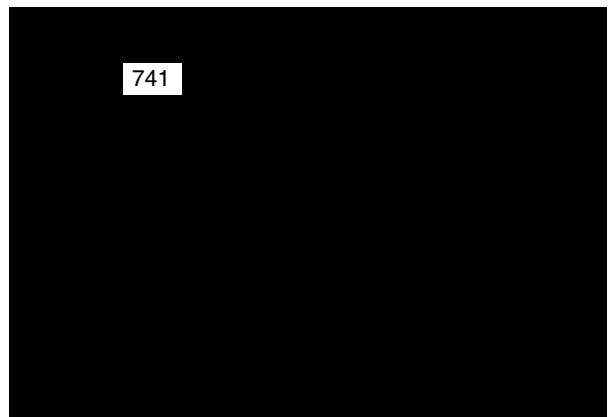

Figure 33. Notch Frequency vs. C1

Typical Applications (continued)



Figure 34. Multiple Aperture Window Discriminator

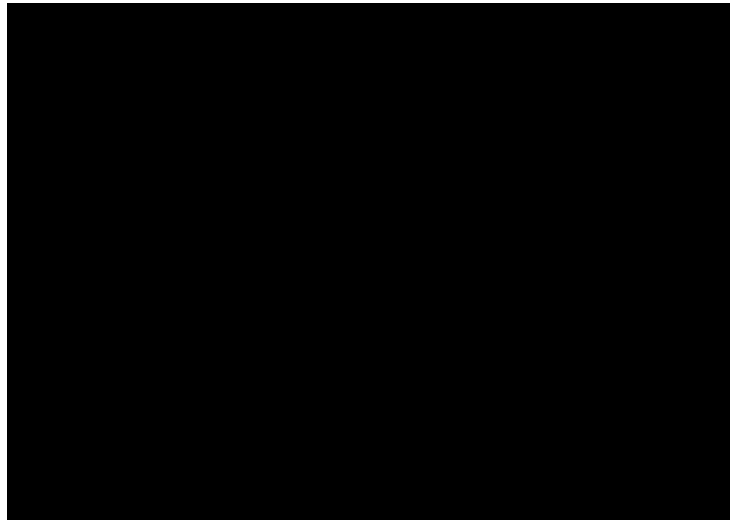

Figure 35. Differential Input Instrumentation Amplifier with High Common Mode Rejection

Typical Applications (continued)

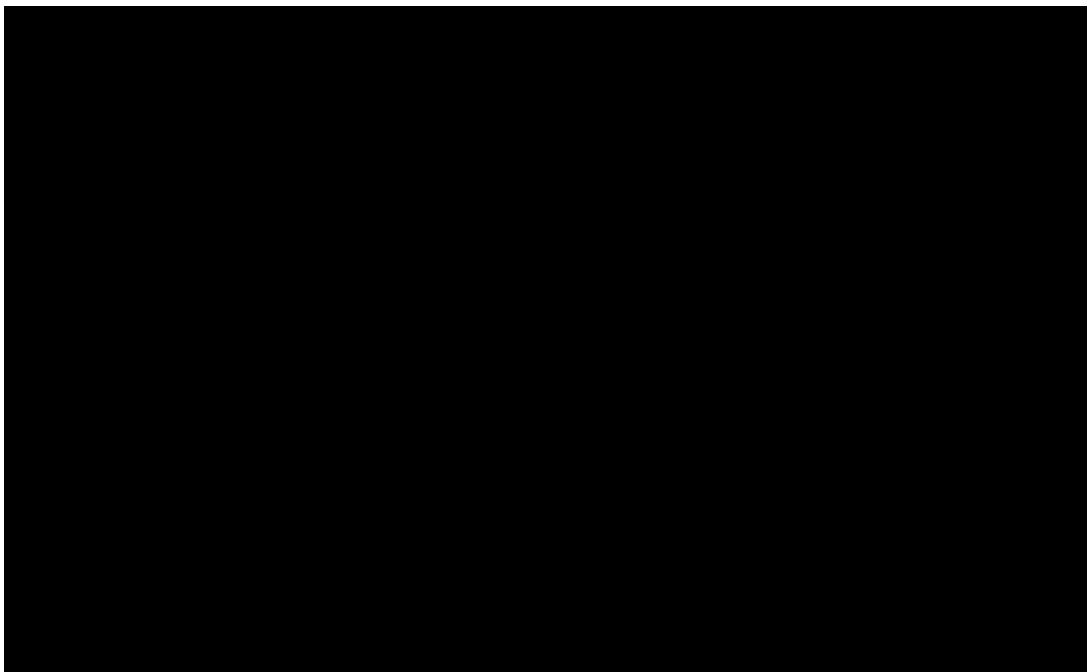

Figure 36. Analog Multiplier/Divider

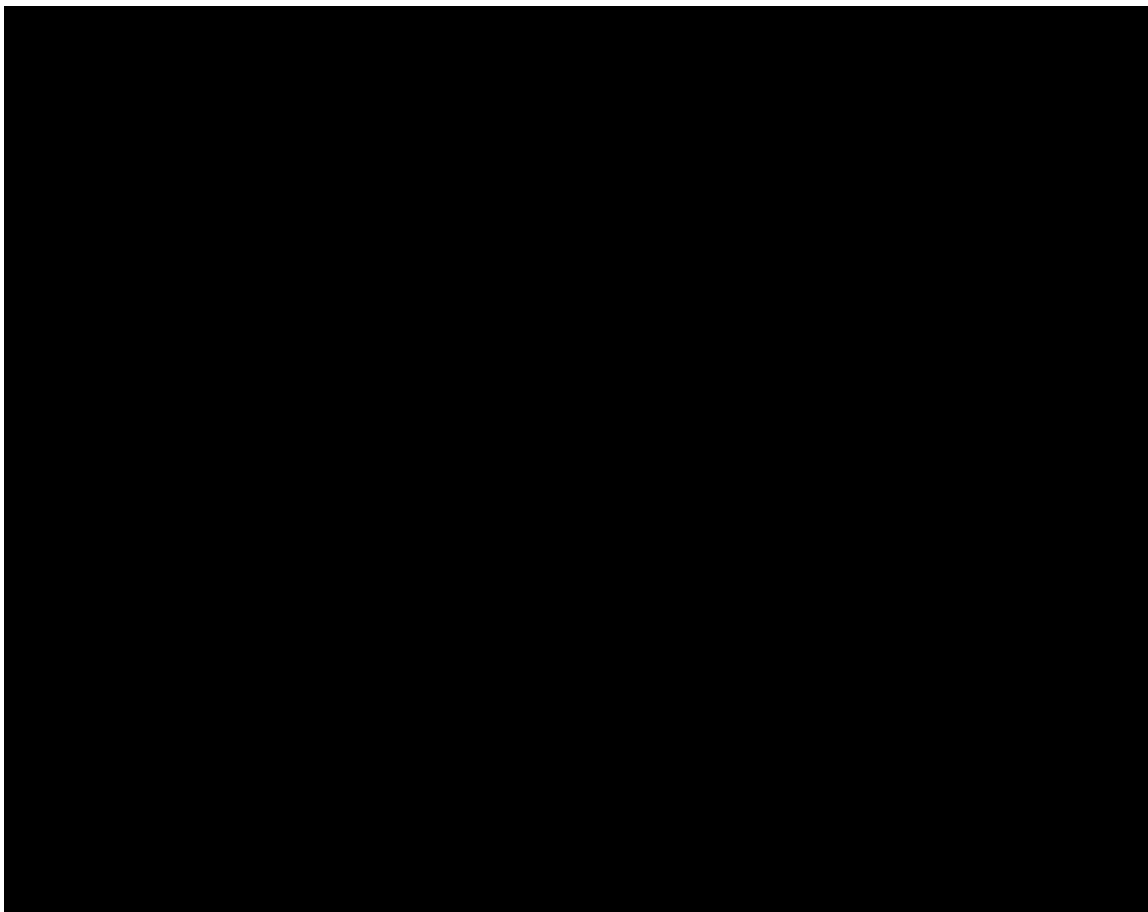
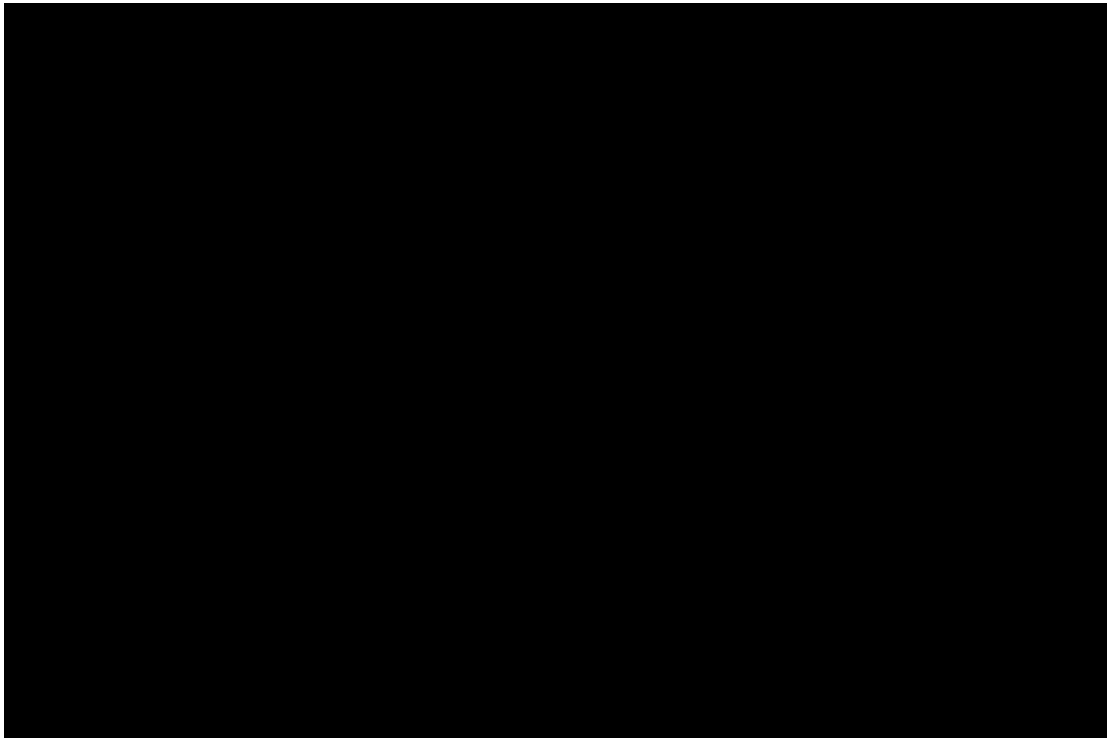

Figure 37. Spot Noise Measurement Test Circuit

Simplified Schematic Diagram



Mechanical Dimensions (continued)

14-Lead Plastic DIP Package

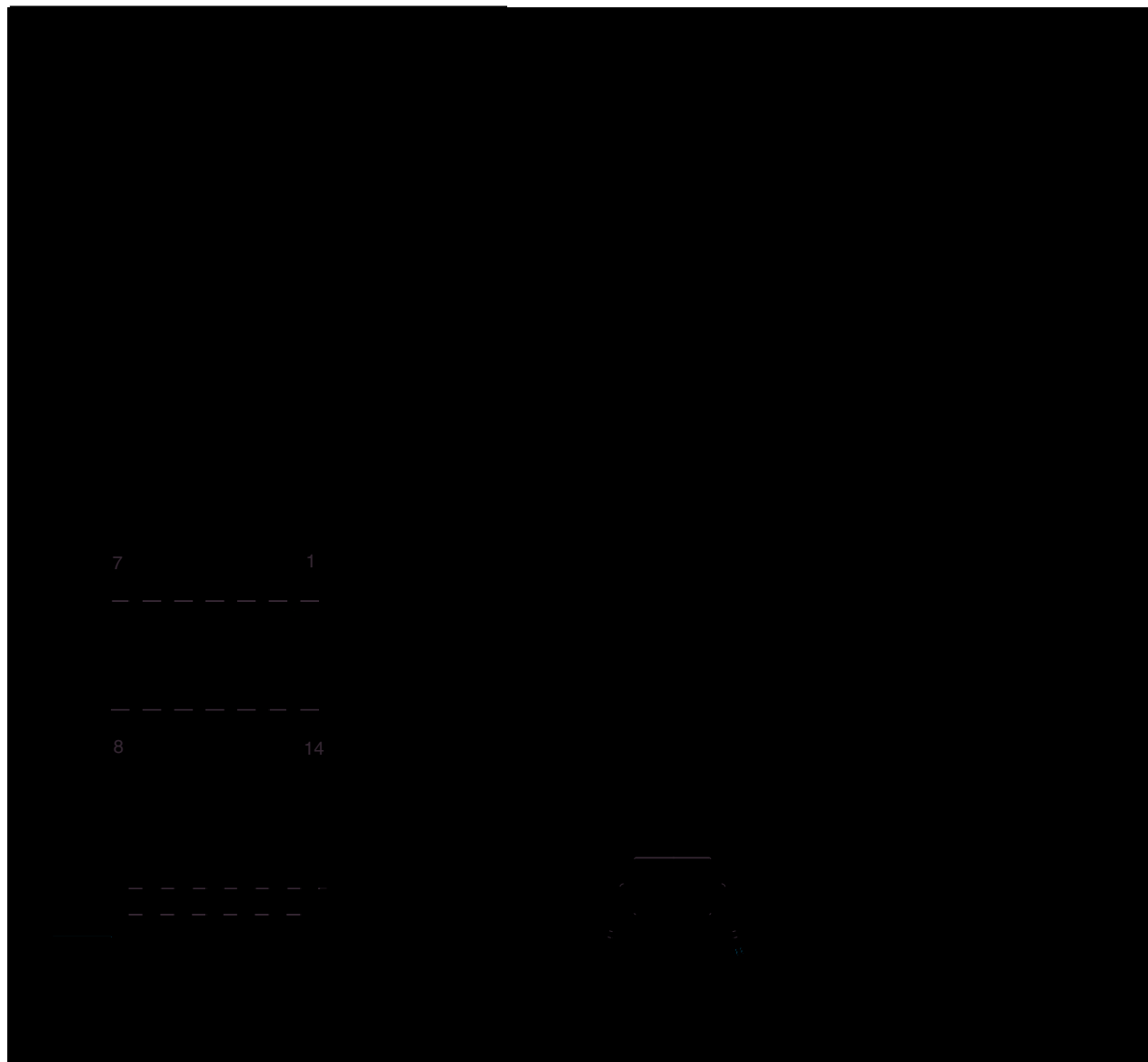

Mechanical Dimensions (continued)

14-Lead SOIC Package

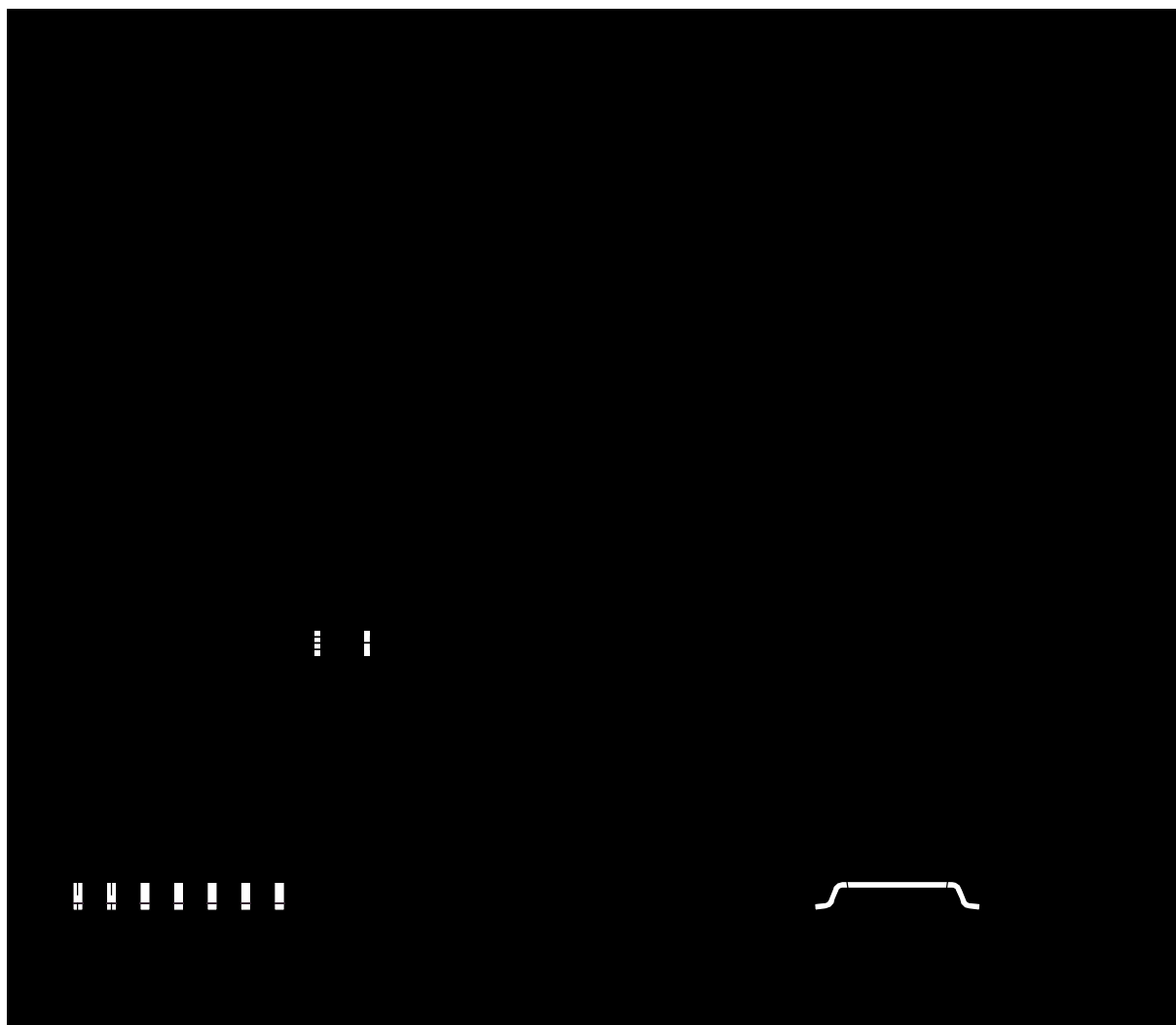

Ordering Information

Product Number	Temperature Range	Screening	Package	Package Marking
RC4136N	0° to 70°C	Commercial	14 Pin Plastic DIP	RC4136N
RC4136M	0° to 70°C	Commercial	14 Pin Narrow SOIC	RC4136M

DISCLAIMER

FAIRCHILD SEMICONDUCTOR RESERVES THE RIGHT TO MAKE CHANGES WITHOUT FURTHER NOTICE TO ANY PRODUCTS HEREIN TO IMPROVE RELIABILITY, FUNCTION OR DESIGN. FAIRCHILD DOES NOT ASSUME ANY LIABILITY ARISING OUT OF THE APPLICATION OR USE OF ANY PRODUCT OR CIRCUIT DESCRIBED HEREIN; NEITHER DOES IT CONVEY ANY LICENSE UNDER ITS PATENT RIGHTS, NOR THE RIGHTS OF OTHERS.

LIFE SUPPORT POLICY

FAIRCHILD'S PRODUCTS ARE NOT AUTHORIZED FOR USE AS CRITICAL COMPONENTS IN LIFE SUPPORT DEVICES OR SYSTEMS WITHOUT THE EXPRESS WRITTEN APPROVAL OF THE PRESIDENT OF FAIRCHILD SEMICONDUCTOR CORPORATION. As used herein:

1. Life support devices or systems are devices or systems which, (a) are intended for surgical implant into the body, or (b) support or sustain life, and (c) whose failure to perform when properly used in accordance with instructions for use provided in the labeling, can be reasonably expected to result in a significant injury of the user.
2. A critical component in any component of a life support device or system whose failure to perform can be reasonably expected to cause the failure of the life support device or system, or to affect its safety or effectiveness.