

Transfer or duplication of this document as well as the utilisation or communication of its content are not permitted unless express consent is granted. Violations give rise to claims for damages. All rights reserved in case of patent, utility model or design patent registrations.

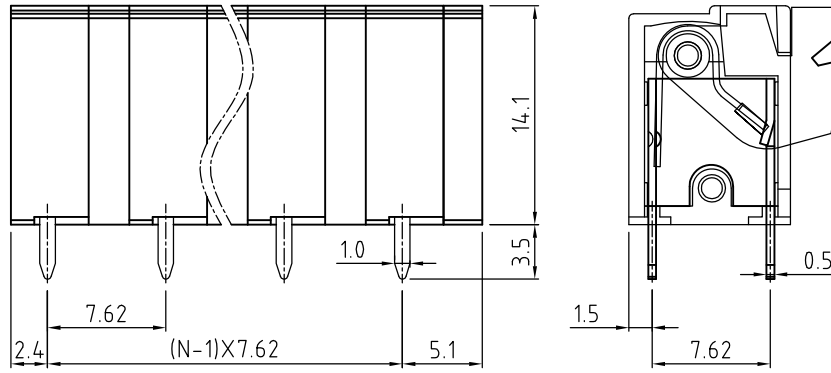

N=Number of contacts

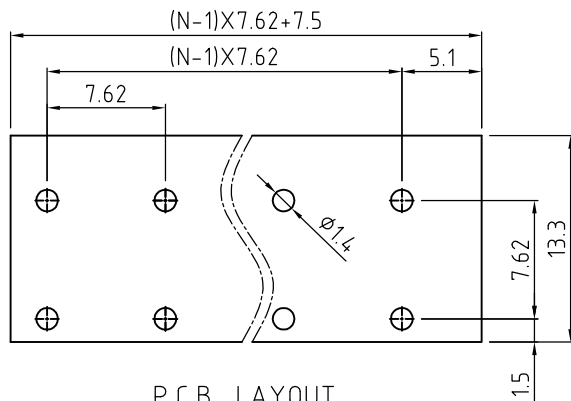
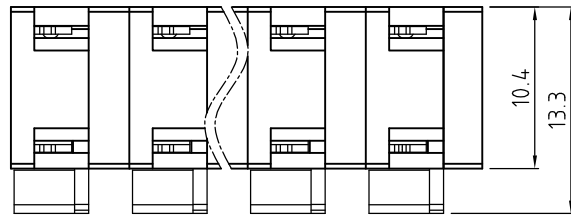

P.C.B. LAYOUT

Technical Data:

Electrical

Pitch: 7.62MM

Voltage rating: 300V

Current rating: 10 Amps

Contact resistance: 20mΩ(max)

Withstanding Voltage: 2500VAC(1min) Test time=60sec/1pcs

Wire Range:14-22AWG

Wire strip length: 6-7MM

Mechanical:

Operating temperature: -40°C to +105°C

Soldering temperature:

Temperature= 250°C±10°C

5 seconds max

Safety approval:

RoHS Compliance

Part No.:

OSTHAXX2050

No. of Poles

02 2 Poles

03 3 Poles

... ..

24 24 Poles

COLOR

0: Black

2: Red

3: Orange

4: Yellow

5: Green (Standard)

6: Blue

8: Grey

Nonstandard colors
Mins could apply

6	Terminal	Copper Alloy	Tin plated	1xN
5	Spring clamp	Stainless steel		1xN
4	Lever	PA66 UL94V-0		1xN
3	Layer	PA66 UL94V-0		N-1
2	Cover	PA66 UL94V-0		1
1	Body	PA66 UL94V-0		1xN
ITEM	NAME OF PART	MATERIAL	NOTES	Q"TY
DWG.	DATE	UNITS: MM	SHEET: 1 OF 1	Tolerance
CHK.	DATE	SCALE: NONE 3:1 (:)	REV.: A	X. ±0.50
APP.	DATE	TITLE: OSTHA SERIES 7.62MM VERTICAL (90° WIRE INLET)		X.XX ±0.30
		PART NO. OSTHAXX2050		X° ±1°
		DWG NO. OSTHAXX2050.DWG		

REV	△	DESCRIPTION	CHK.	DATE
-----	---	-------------	------	------



ON-SHORE TECHNOLOGY, INC.