

LOC		DIST		REVISIONS			
GP	00	REV	DATE	BY	APPV	DATE	REV
G		REVISED PER ECR-13-008593	13SEP2013	KH	TM		

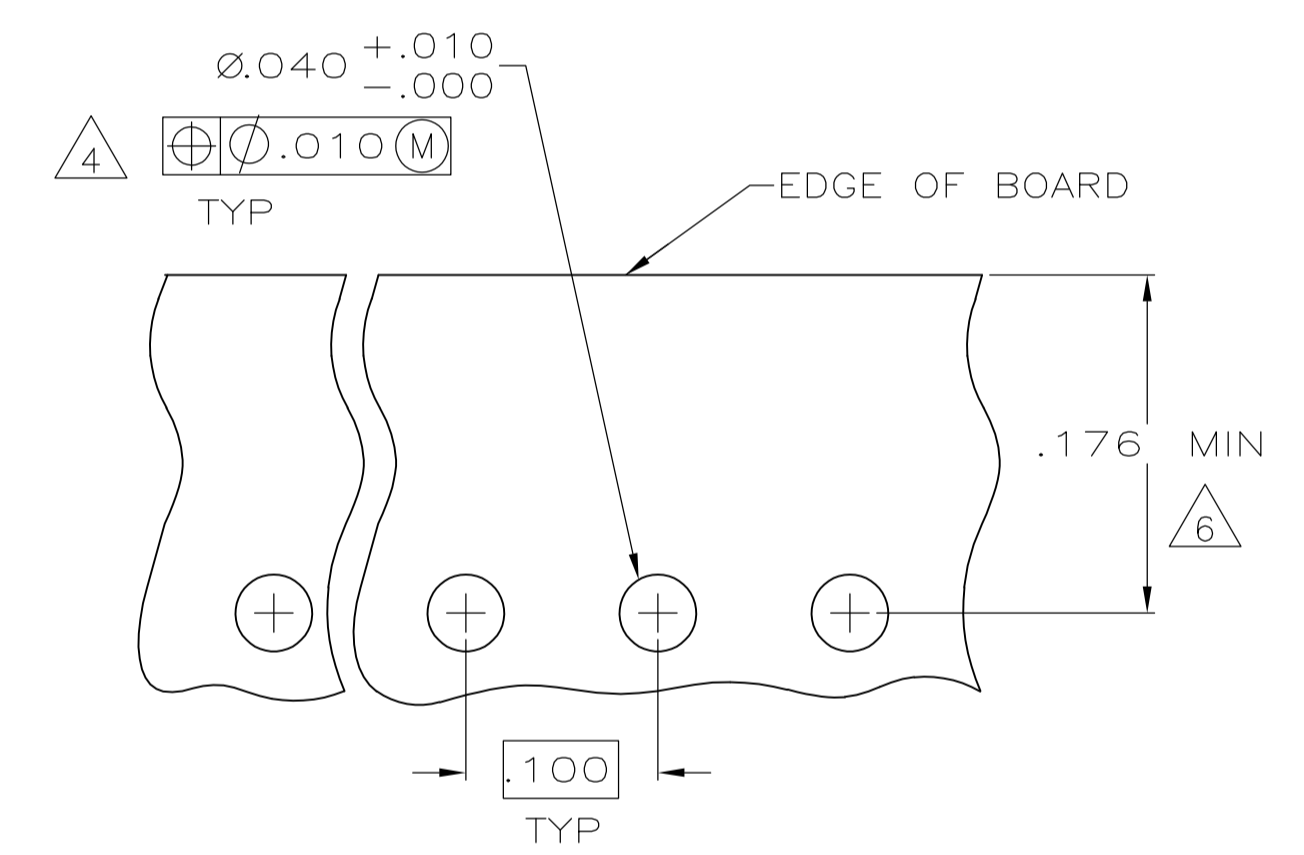
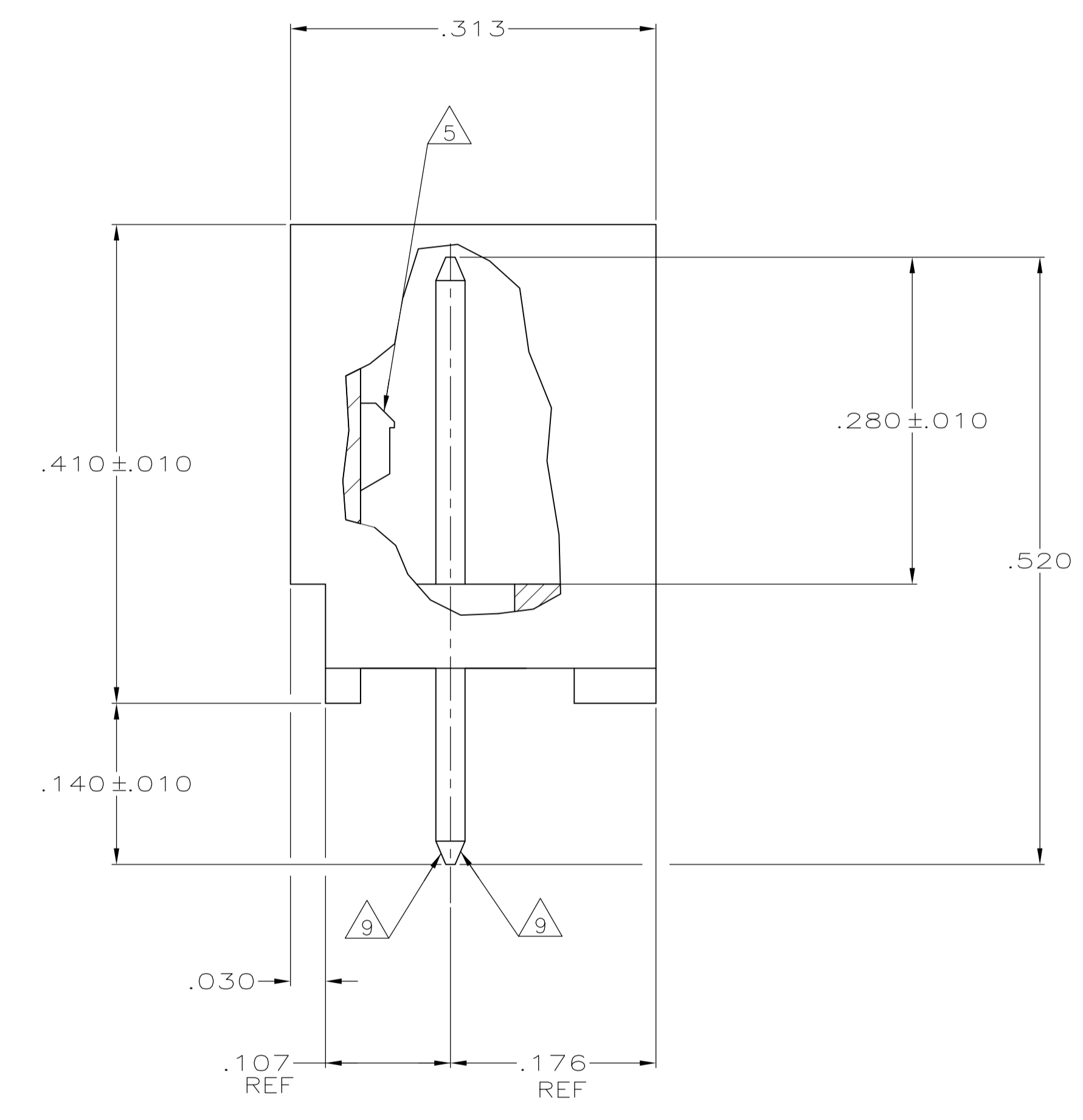
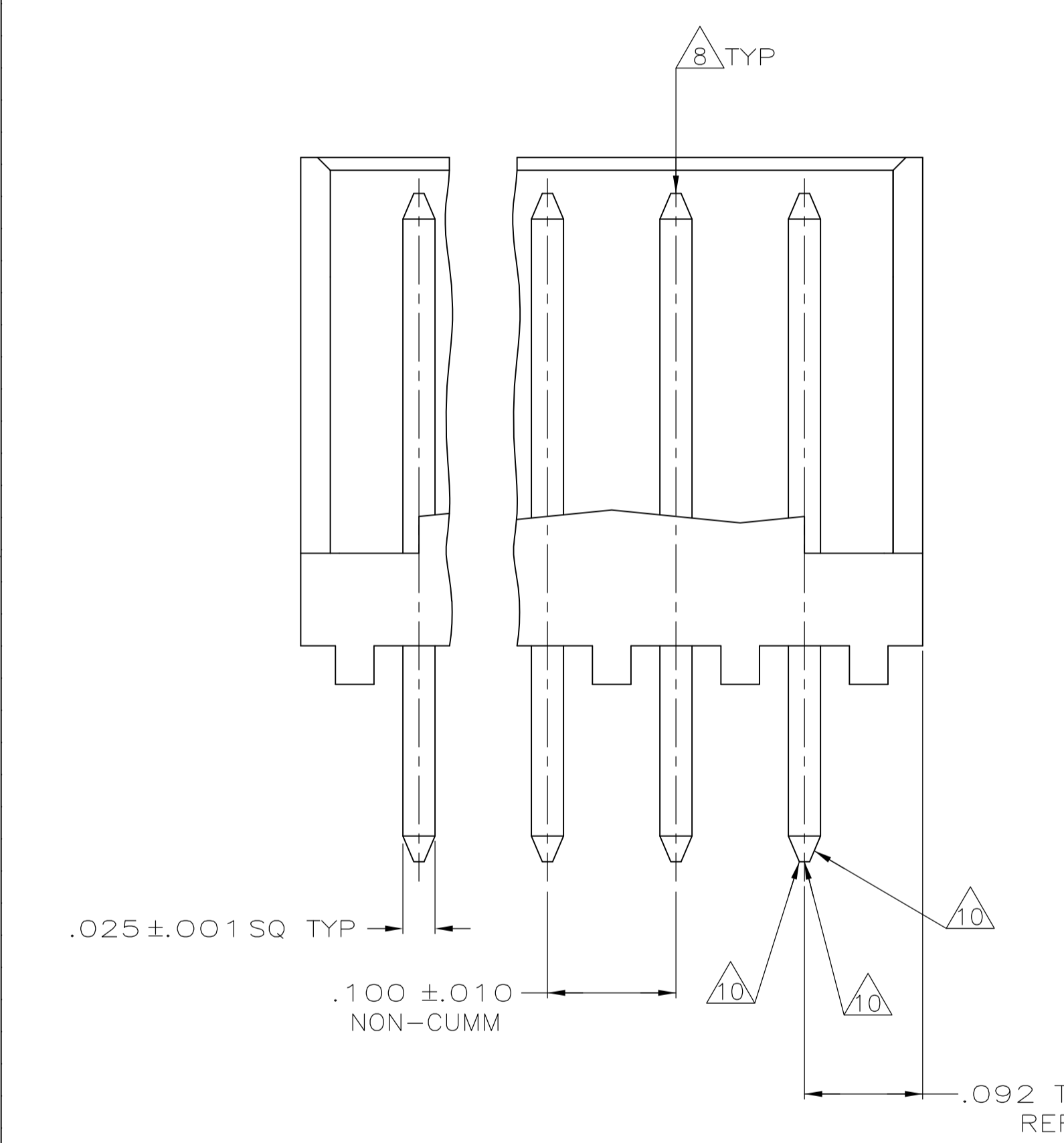
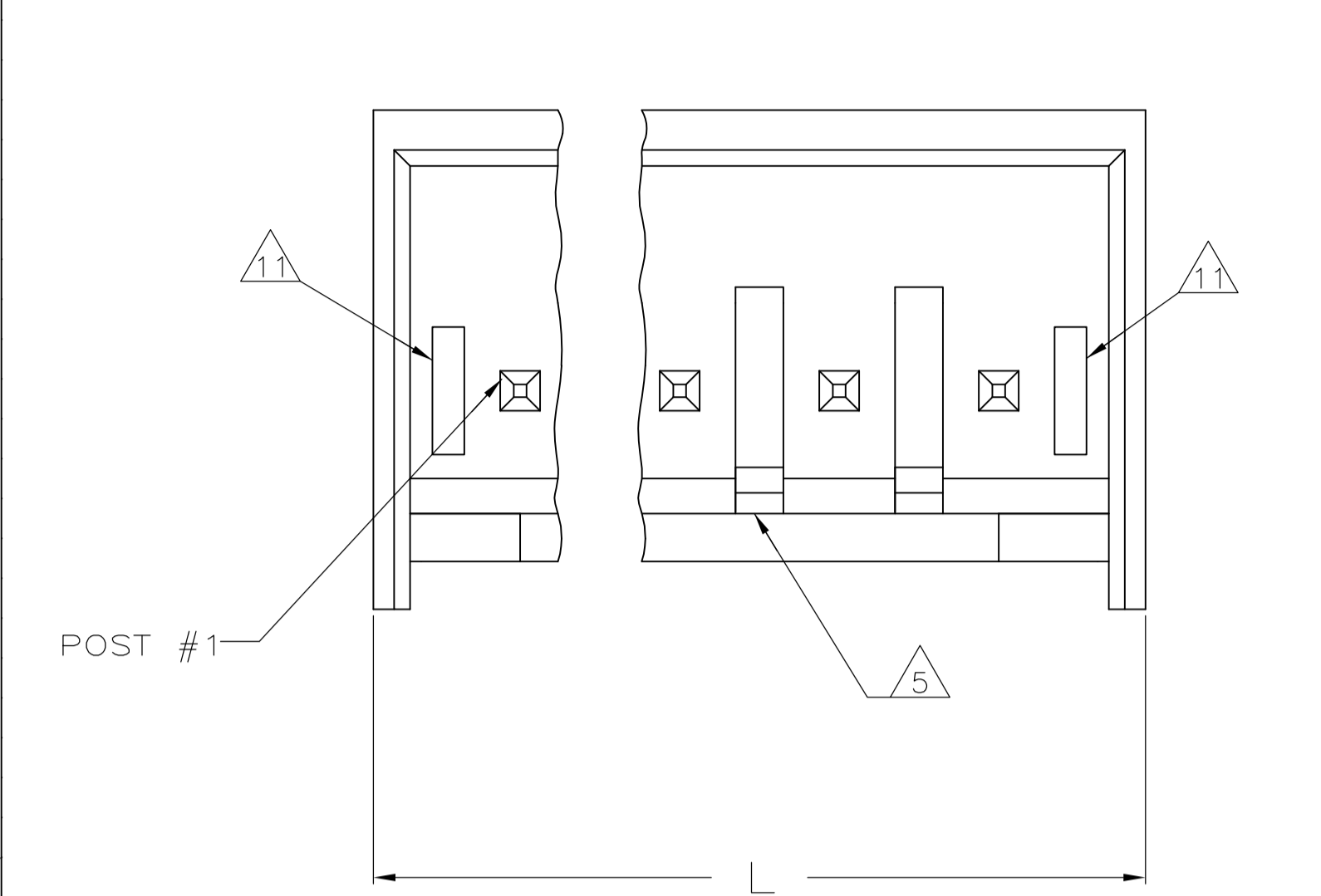

- 1 MATERIAL: HEADER - POLYESTER UL94V-0 (BLACK)
POST - COPPER ALLOY.
- 2 SOLDER SIDE OF P.C. BOARD SHOWN.
- 3 PARTS COMPLY WITH AMP SOLDERABILITY SPEC 109-11-2.
- 4 ONE HOLE MAY BE UNDERSIZED (.032-.035 DIA) FOR ASSEMBLY RETENTION DURING WAVE SOLDERING.
- 5 LATCH DETENT FEATURE OCCURS 2 PLACES ON EACH END (MAXIMUM OF FOUR PER PART). FOR 2 THRU 5 CIRCUIT HEADERS, LATCH FEATURE OCCURS BETWEEN EACH CIRCUIT.
- 6 COORDINATE DIMENSION APPLIES FROM CENTER OF ACTUAL FEATURE.
- 7 POST: 93/7 BRIGHT TIN-LEAD PLATING (-2 THRU -14) OR 100% MATTE TIN PLATING (-32 THRU -44).
- 8 POST MUST WITHSTAND 3.0 LBS (13.34 NEWTONS) MIN FORCE WITHOUT DISLODGING, EITHER DIRECTION.
- 9 TWO SIDES OF TAPER, AS SHOWN, MUST BE PLATED. TYPICAL, BOTH ENDS.
- 10 TWO SIDES OF TAPER, AS SHOWN, AND TIP MAY BE UNPLATED. TYPICAL, BOTH ENDS.
- 11 SLOTS MAY OR MAY NOT APPEAR ON THESE PARTS.
- 12 UL RECOGNIZED (UR) LOGO AND CSA LOGO WILL APPEAR ON THE SIDE OF THE PART. THE AMP LOGO MAY APPEAR ON THE SIDE OR ON BOTTOM OF PART.

RECOMMENDED MOUNTING HOLE PATTERN FOR .063 THK PRINTED CIRCUIT BOARD

IN	MM	NO OF POSITIONS	PART NUMBER
1.484	37.69	14	4-644892-4
1.384	35.15	13	4-644892-3
1.284	32.61	12	4-644892-2
1.184	30.07	11	4-644892-1
1.084	27.53	10	4-644892-0
.984	24.99	9	3-644892-9
.884	22.45	8	3-644892-8
.784	19.91	7	3-644892-7
.684	17.37	6	3-644892-6
.584	14.83	5	3-644892-5
.484	12.29	4	3-644892-4
.384	9.75	3	3-644892-3
.284	7.21	2	3-644892-2

.025	0.64	.100	2.54	.520	13.21
.010	0.25	.092	2.34	.410	10.41
.005	0.13	.063	1.60	.313	7.95
.001	0.03	.040	1.02	.280	7.11
.000350	0.00889	.035	0.89	.176	4.47
.000150	0.00381	.032	0.81	.140	3.56
.000	0.00	.030	0.76	.107	2.72
IN	MM	IN	MM	IN	MM

CONVERSION TABLE

THIS DRAWING IS A CONTROLLED DOCUMENT.

DIMENSIONS: INCHES	TOLERANCES UNLESS OTHERWISE SPECIFIED:	DRAWING NO	RESTRICTED TO
0 PLC ± -	1 PLC ± -	24JUNE2005	
2 PLC ± -	3 PLC ± .005	24JUNE2005	
4 PLC ± -	ANGLES ± -		

MATERIAL: 1 FINISH: 7

APPROVED: K. WHITAKER, D. ROSSI, D. ROSSI

NAME: CST-100 SHROUDED HEADER ASSEMBLY, FRICTION LOCK, STRAIGHT POST, TIN OR TIN LEAD PLATED

SIZE: A1, WEIGHT: 00779, SCALE: 10:1, SHEET: 1 OF 1, REV: G