



## Value SSTL\_2 Clock Driver (60MHz - 220MHz)

### Recommended Application:

Zero delay board fan-out memory modules

### Product Description/Features:

- Meets PC3200 specification for DDRI-400 support
- Low skew, low jitter PLL clock driver
- 1 to 10 differential clock distribution (SSTL\_2)
- Feedback pins for input to output synchronization
- PD# for power management
- Spread Spectrum tolerant inputs
- Auto PD when input signal removed

### Switching Characteristics:

- CYCLE - CYCLE jitter (>100MHz): <75ps
- OUTPUT - OUTPUT skew: <100ps

### Pin Configuration

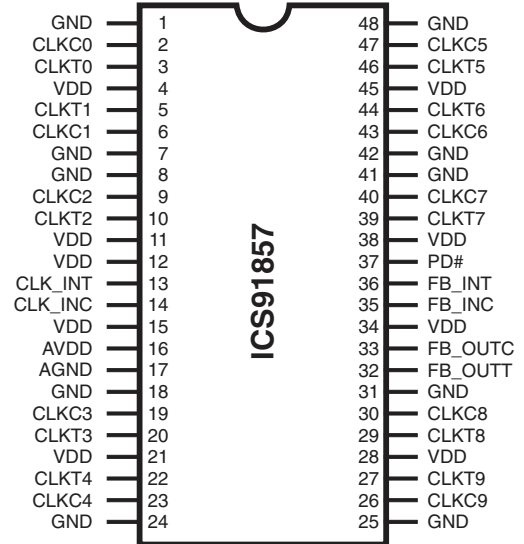

### 48-Pin TSSOP

6.10 mm. Body, 0.50 mm. pitch TSSOP

### Functionality

INPUTS				OUTPUTS				PLL State
AVDD	PD#	CLK_INT	CLK_INC	CLKT	CLKC	FB_OUTT	FB_OUTC	
GND	H	L	H	L	H	L	H	Bypassed/off
GND	H	H	L	H	L	H	L	Bypassed/off
2.5V (nom)	L	L	H	Z	Z	Z	Z	off
2.5V (nom)	L	H	L	Z	Z	Z	Z	off
2.5V (nom)	H	L	H	L	H	L	H	on
2.5V (nom)	H	H	L	H	L	H	L	on
2.5V (nom)	X	<20MHz <sup>(1)</sup>		Z	Z	Z	Z	off

### Block Diagram

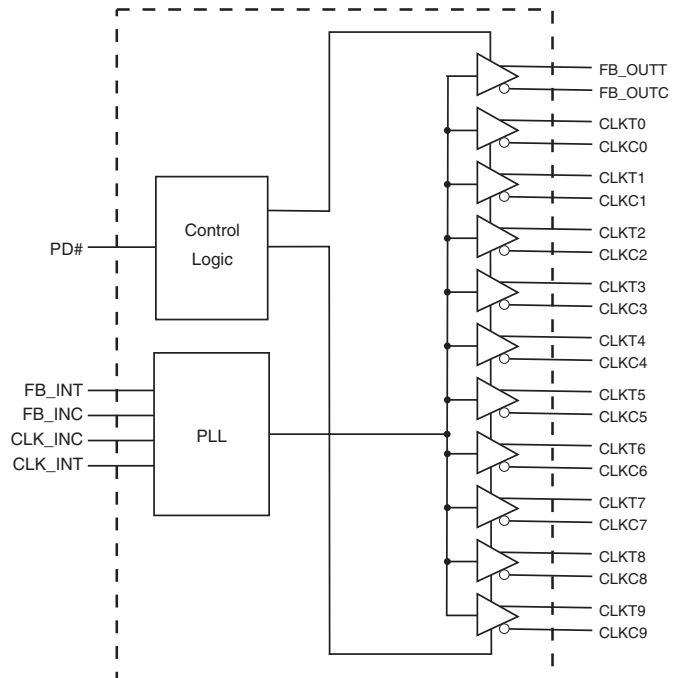

## Pin Descriptions

PIN NUMBER	PIN NAME	TYPE	DESCRIPTION
4, 11, 12, 15, 21, 28, 34, 38, 45,	VDD	PWR	Power supply 2.5V up to DDR 333. Power supply 2.6V for DDR-I at 400MHz.
1, 7, 8, 18, 24, 25, 31, 41, 42, 48	GND	PWR	Ground
16	AVDD	PWR	Analog power supply, 2.5V up to DDR 333. Power supply 2.6V for DDR-I at 400MHz.
17	AGND	PWR	Analog ground.
27, 29, 39, 44, 46, 22, 20, 10, 5, 3	CLKT(9:0)	OUT	"True" Clock of differential pair outputs.
26, 30, 40, 43, 47, 23, 19, 9, 6, 2	CLKC(9:0)	OUT	"Complementary" clocks of differential pair outputs.
14	CLK_INC	IN	"Complementary" reference clock input
13	CLK_INT	IN	"True" reference clock input
33	FB_OUTC	OUT	"Complementary" Feedback output, dedicated for external feedback. It switches at the same frequency as the CLK. This output must be wired to FB_INC.
32	FB_OUTT	OUT	"True" Feedback output, dedicated for external feedback. It switches at the same frequency as the CLK. This output must be wired to FB_INT.
36	FB_INT	IN	"True" Feedback input, provides feedback signal to the internal PLL for synchronization with CLK_INT to eliminate phase error.
35	FB_INC	IN	"Complementary" Feedback input, provides signal to the internal PLL for synchronization with CLK_INC to eliminate phase error.
37	PD#	IN	Power Down. LVCMOS input

This PLL Clock Buffer is designed for a  $V_{DD}$  of 2.5V, an  $AV_{DD}$  of 2.5V and differential data input and output levels.

**ICS91857** is a zero delay buffer that distributes a differential clock input pair (CLK\_INC, CLK\_INT) to ten differential pair of clock outputs (CLKT[0:9], CLKC[0:9]) and one differential pair feedback clock output (FB\_OUT, FB\_OUTC). The clock outputs are controlled by the input clocks (CLK\_INC, CLK\_INT), the feedback clocks (FB\_INT, FB\_INC) the 2.5-V LVCMOS input (PD#) and the Analog Power input ( $AV_{DD}$ ). When input (PD#) is low while power is applied, the receivers are disabled, the PLL is turned off and the differential clock outputs are Tri-States. When  $AV_{DD}$  is grounded, the PLL is turned off and bypassed for test purposes.

When the input frequency is less than the operating frequency of the PLL, approximately 20MHz, the device will enter a low power mode. An input frequency detection circuit on the differential inputs, independent from the input buffers, will detect the low frequency condition and perform the same low power features as when the (PD#) input is low. When the input frequency increases to greater than approximately 20 MHz, the PLL will be turned back on, the inputs and outputs will be enabled and PLL will obtain phase lock between the feedback clock pair (FB\_INT, FB\_INC) and the input clock pair (CLK\_INC, CLK\_INT).

The PLL in the **ICS91857** clock driver uses the input clocks (CLK\_INC, CLK\_INT) and the feedback clocks (FB\_INT, FB\_INC) provide high-performance, low-skew, low-jitter output differential clocks (CLKT [0:9], CLKC [0:9]). The ICS91857 is also able to track Spread Spectrum Clock (SSC) for reduced EMI.

**ICS91857** is characterized for operation from 0°C to 70°C and will meet JEDEC Standard 82-1 and 82-1A for Registered DDR Clock Driver.

## Absolute Maximum Ratings

Supply Voltage (VDD & AVDD)	-0.5V to 4.6V
Logic Inputs	GND -0.5 V to V <sub>DD</sub> + 0.5 V
Ambient Operating Temperature	0°C to +70°C
Storage Temperature	-65°C to +150°C

Stresses above those listed under *Absolute Maximum Ratings* may cause permanent damage to the device. These ratings are stress specifications only and functional operation of the device at these or any other conditions above those listed in the operational sections of the specifications is not implied. Exposure to absolute maximum rating conditions for extended periods may affect product reliability.

## Electrical Characteristics for DDR200/266/333 - Input/Supply/Common Output Parameters

T<sub>A</sub> = 0 - 70°C; Supply Voltage A<sub>VDD</sub>, V<sub>DD</sub> = 2.5V ± 0.2V (unless otherwise stated)

PARAMETER	SYMBOL	CONDITIONS	MIN	TYP	MAX	UNITS
Input High Current	I <sub>IH</sub>	V <sub>I</sub> = V <sub>DD</sub> or GND	5			μA
Input Low Current	I <sub>IL</sub>	V <sub>I</sub> = V <sub>DD</sub> or GND			5	μA
Operating Supply Current	I <sub>DD2.5</sub>	C <sub>L</sub> = 0pf @ 200MHz		260		mA
	I <sub>DDPD</sub>	C <sub>L</sub> = 0pf			100	mA
Output High Current	I <sub>OH</sub>	V <sub>DD</sub> = 2.3V, V <sub>OUT</sub> = 1V	-18	-32		mA
Output Low Current	I <sub>OL</sub>	V <sub>DD</sub> = 2.3V, V <sub>OUT</sub> = 1.2V	26	35		mA
High Impedance Output Current	I <sub>OZ</sub>	V <sub>DD</sub> =2.7V, V <sub>out</sub> =V <sub>DD</sub> or GND			±10	mA
Input Clamp Voltage	V <sub>IK</sub>	V <sub>DDQ</sub> = 2.3V I <sub>in</sub> = -18mA			-1.2	V
High-level output voltage	V <sub>OH</sub>	V <sub>DD</sub> = min to max, I <sub>OH</sub> = -1 mA	V <sub>DDQ</sub> - 0.1			V
		V <sub>DDQ</sub> = 2.3V, I <sub>OH</sub> = -12 mA	1.7			V
Low-level output voltage	V <sub>OL</sub>	V <sub>DD</sub> = min to max I <sub>OL</sub> =1 mA			0.1	V
		V <sub>DDQ</sub> = 2.3V I <sub>OH</sub> =12 mA			0.6	V
Input Capacitance <sup>1</sup>	C <sub>IN</sub>	V <sub>I</sub> = GND or V <sub>DD</sub>		3		pF
Output Capacitance <sup>1</sup>	C <sub>OUT</sub>	V <sub>OUT</sub> = GND or V <sub>DD</sub>		3		pF

<sup>1</sup>Guaranteed by design at 170MHz, not 100% tested in production.

## Electrical Characteristics for DDRI-400 - Input/Supply/Common Output Parameters

$T_A = 0 - 70^\circ\text{C}$ ; Supply Voltage  $A_{V_{DD}}$ ,  $V_{DD} = 2.6\text{V} \pm 0.1\text{V}$

PARAMETER	SYMBOL	CONDITIONS	MIN	TYP	MAX	UNITS
Input High Current	$I_{IH}$	$V_I = V_{DD}$ or GND	5			$\mu\text{A}$
Input Low Current	$I_{IL}$	$V_I = V_{DD}$ or GND			5	$\mu\text{A}$
Operating Supply Current	$I_{DD2.5}$	$C_L = 0\text{pf}$ @ 200MHz		260		mA
	$I_{DDPD}$	$C_L = 0\text{pf}$			100	mA
Output High Current	$I_{OH}$	$V_{DD} = 2.3\text{V}$ , $V_{OUT} = 1\text{V}$	-18	-32		mA
Output Low Current	$I_{OL}$	$V_{DD} = 2.3\text{V}$ , $V_{OUT} = 1.2\text{V}$	26	35		mA
High Impedance Output Current	$I_{OZ}$	$V_{DD}=2.7\text{V}$ , $V_{out}=V_{DD}$ or GND			$\pm 10$	mA
Input Clamp Voltage	$V_{IK}$	$V_{DDQ} = 2.3\text{V}$ $I_{in} = -18\text{mA}$			-1.2	V
High-level output voltage	$V_{OH}$	$V_{DD} = \text{min to max}$ , $I_{OH} = -1\text{ mA}$	$V_{DDQ} - 0.1$			V
		$V_{DDQ} = 2.3\text{V}$ , $I_{OH} = -12\text{ mA}$	1.7			V
Low-level output voltage	$V_{OL}$	$V_{DD} = \text{min to max}$ $I_{OL}=1\text{ mA}$			0.1	V
		$V_{DDQ} = 2.3\text{V}$ $I_{OH}=12\text{ mA}$			0.6	V
Input Capacitance <sup>1</sup>	$C_{IN}$	$V_I = \text{GND}$ or $V_{DD}$		3		pF
Output Capacitance <sup>1</sup>	$C_{OUT}$	$V_{OUT} = \text{GND}$ or $V_{DD}$		3		pF

<sup>1</sup>Guaranteed by design at 220MHz, not 100% tested in production.

### Recommended Operating Condition for DDR200/266/333 (see note1)

$T_A = 0 - 85^{\circ}\text{C}$ ; Supply Voltage AVDD, VDD =  $2.5\text{V} \pm 0.2\text{V}$  (unless otherwise stated)

PARAMETER	SYMBOL	CONDITIONS	MIN	TYP	MAX	UNITS
Supply Voltage	$V_{DDQ}, A_{VDD}$		2.3		2.7	V
Low level input voltage	$V_{IL}$	CLKT, CLKC, FB_INC			$V_{DDQ}/2 - 0.18$	V
		PD#	-0.3		0.7	V
High level input voltage	$V_{IH}$	CLKT, CLKC, FB_INC	$V_{DDQ}/2 + 0.18$			V
		PD#	1.7		$V_{DDQ} + 0.6$	V
DC input signal voltage (note 2)			-0.3		$V_{DDQ}$	V
Differential input signal voltage (note 3)	$V_{ID}$	DC - CLKT, FB_INT	0.36		$V_{DDQ} + 0.6$	V
		AC - CLKT, FB_INT	0.7		$V_{DDQ} + 0.6$	V
Output differential cross-voltage (note 4)	$V_{OX}$		$V_{DDQ}/2 - 0.15$		$V_{DDQ}/2 + 0.15$	V
Input differential cross-voltage (note 4)	$V_{IX}$		$V_{DDQ}/2 - 0.2$		$V_{DDQ}/2 + 0.2$	V
High level output current	$I_{OH}$				0.12	mA
Low level output current	$I_{OL}$				12	mA
Input slew rate	$S_R$		1		4	V/ns
Operating free-air temperature	$T_A$		0		70	$^{\circ}\text{C}$

#### Notes:

- Unused inputs must be held high or low to prevent them from floating.
- DC input signal voltage specifies the allowable DC execution of differential input.
- Differential inputs signal voltages specifies the differential voltage [VTR-VCP] required for switching, where VT is the true input level and VCP is the complementary input level.
- Differential cross-point voltage is expected to track variations of  $V_{CC}$  and is the voltage at which the differential signal must be crossing.

### Recommended Operating Condition for DDRI-400 (see note1)

$T_A = 0 - 70^{\circ}\text{C}$ ; Supply Voltage AVDD, VDD =  $2.6\text{V} \pm 0.1\text{V}$

PARAMETER	SYMBOL	CONDITIONS	MIN	TYP	MAX	UNITS
Supply Voltage	$V_{DDQ}, A_{VDD}$		2.5	2.6	2.7	V
Low level input voltage	$V_{IL}$	CLKT, CLKC, FB_INC			$V_{DDQ}/2 - 0.18$	V
		PD#	-0.3		0.7	V
High level input voltage	$V_{IH}$	CLKT, CLKC, FB_INC	$V_{DDQ}/2 + 0.18$			V
		PD#	1.7		$V_{DDQ} + 0.3$	V
DC input signal voltage (note 2)			-0.3		$V_{DDQ}$	V
Differential input signal voltage (note 3)	$V_{ID}$	DC - CLKT, FB_INT	0.36		$V_{DDQ} + 0.6$	V
		AC - CLKT, FB_INT	0.7		$V_{DDQ} + 0.6$	V
Output differential cross-voltage (note 4)	$V_{OX}$		$V_{DDQ}/2 - 0.15$		$V_{DDQ}/2 + 0.15$	V
Input differential cross-voltage (note 4)	$V_{IX}$		$V_{DDQ}/2 - 0.2$		$V_{DDQ}/2 + 0.2$	V
High level output current	$I_{OH}$				12	mA
Low level output current	$I_{OL}$				-12	mA
Input slew rate	$S_R$		1		4	V/ns
Operating free-air temperature	$T_A$		0		70	$^{\circ}\text{C}$

#### Notes:

- Unused inputs must be held high or low to prevent them from floating.
- DC input signal voltage specifies the allowable DC execution of differential input.
- Differential inputs signal voltages specifies the differential voltage [VTR-VCP] required for switching, where VT is the true input level and VCP is the complementary input level.
- Differential cross-point voltage is expected to track variations of  $V_{CC}$  and is the voltage at which the differential signal must be crossing.

### Timing Requirements for DDR200/266/333

$T_A = 0 - 70^\circ\text{C}$ ; Supply Voltage  $A_{VDD}$ ,  $V_{DD} = 2.5\text{V} \pm 0.2\text{V}$  (unless otherwise stated)

PARAMETER	SYMBOL	CONDITIONS	MIN	MAX	UNITS
Max clock frequency	$\text{freq}_{\text{op}}$	$2.5\text{V} \pm 0.2\text{V} @ 25^\circ\text{C}$	60	170	MHz
Application Frequency Range	$\text{freq}_{\text{App}}$	$2.5\text{V} \pm 0.2\text{V} @ 25^\circ\text{C}$	95	170	MHz
Input clock duty cycle	$d_{\text{tin}}$		40	60	%
CLK stabilization	$T_{\text{STAB}}$			100	$\mu\text{s}$

### Timing Requirements for DDRI-400

$T_A = 0 - 70^\circ\text{C}$ ; Supply Voltage  $A_{VDD}$ ,  $V_{DD} = 2.6\text{V} \pm 0.1\text{V}$

PARAMETER	SYMBOL	CONDITIONS	MIN	MAX	UNITS
Max clock frequency	$\text{freq}_{\text{op}}$	$2.6\text{V} \pm 0.1\text{V}$	60	230	MHz
Application Frequency Range	$\text{freq}_{\text{App}}$	$2.6\text{V} \pm 0.1\text{V}$	95	220	MHz
Input clock duty cycle	$d_{\text{tin}}$		40	60	%
CLK stabilization	$T_{\text{STAB}}$			100	$\mu\text{s}$

### Switching Characteristics for DDR200/266/333

PARAMETER	SYMBOL	CONDITION	MIN	TYP	MAX	UNITS
Low-to high level propagation delay time	$t_{\text{PLH}}^1$	CLK_IN to any output		3.5		ns
High-to low level propagation delay time	$t_{\text{PLL}}^1$	CLK_IN to any output		3.5		ns
Output enable time	$t_{\text{EN}}$	PD# to any output		3		ns
Output disable time	$t_{\text{dis}}$	PD# to any output		3		ns
Period jitter	$T_{\text{jit (per)}}$	100 - 200 MHz	-75		75	ps
Half-period jitter	$t_{\text{jit (hper)}}$	100 - 200 MHz	-75		75	
Input clock slew rate	$t_{\text{(sir I)}}$		1		4	V/ns
Output clock slew rate	$t_{\text{(sl_o)}}$		1		2	V/ns
Cycle to Cycle Jitter <sup>1</sup>	$T_{\text{cyc}} - T_{\text{cyc}}$	100 - 200 MHz	-75		75	ps
Static Phase Offset	$t_{\text{(spo)}}^3$		-50	0	50	ps
Output to Output Skew	$T_{\text{skew}}$				100	ps
Pulse skew	$T_{\text{skewp}}$				100	ps

#### Notes:

1. Refers to transition on noninverting output in PLL bypass mode.
2. Switching characteristics guaranteed for application frequency range.
3. Static phase offset shifted by design.

### Switching Characteristics for DDRI-400

PARAMETER	SYMBOL	CONDITION	MIN	TYP	MAX	UNITS
Low-to high level propagation delay time	$t_{PLH}^1$	CLK_IN to any output		3.5		ns
High-to low level propagation delay time	$t_{PLL}^1$	CLK_IN to any output		3.5		ns
Output enable time	$t_{EN}$	PD# to any output		3		ns
Output disable time	$t_{dis}$	PD# to any output		3		ns
Period jitter	$T_{jit(per)}$	100 - 200 MHz	-50		50	ps
Half-period jitter	$t_{jit(hper)}$	100 - 200 MHz	-75		75	
Input clock slew rate	$t_{(sir\ l)}$		1		4	V/ns
Output clock slew rate	$t_{(sl\ o)}$		1		2	V/ns
Cycle to Cycle Jitter <sup>1</sup>	$T_{cyc}-T_{cyc}$	100 - 200 MHz	-75		75	ps
Static Phase Offset	$t_{(spo)}^3$		-50	0	50	ps
Output to Output Skew	$T_{skew}$				75	ps
Pulse skew	$T_{skewp}$				100	ps

**Notes:**

1. Refers to transition on noninverting output in PLL bypass mode.
2. Switching characteristics guaranteed for application frequency range.
3. Static phase offset shifted by design.



Parameter Measurement Information

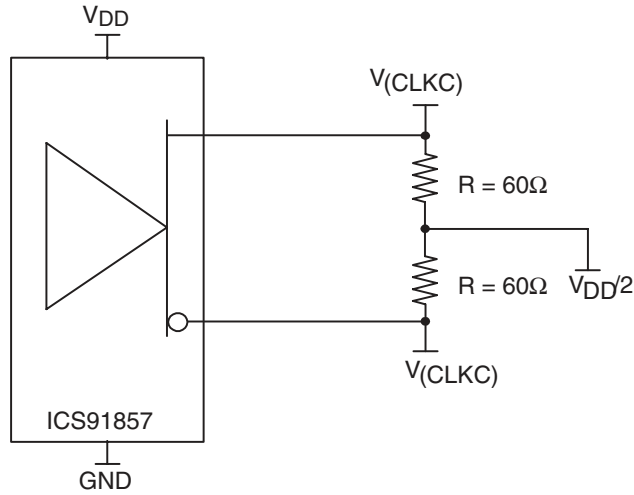
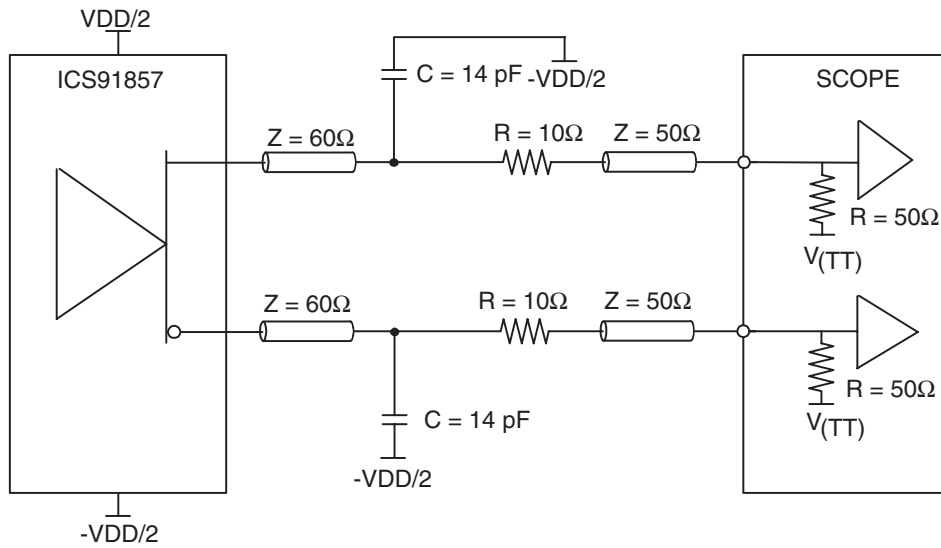

Figure 1. IBIS Model Output Load



NOTE:  $V_{(TT)} = \text{GND}$

Figure 2. Output Load Test Circuit

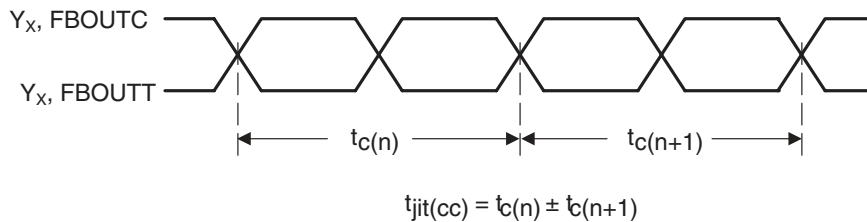

Figure 3. Cycle-to-Cycle Jitter

Parameter Measurement Information

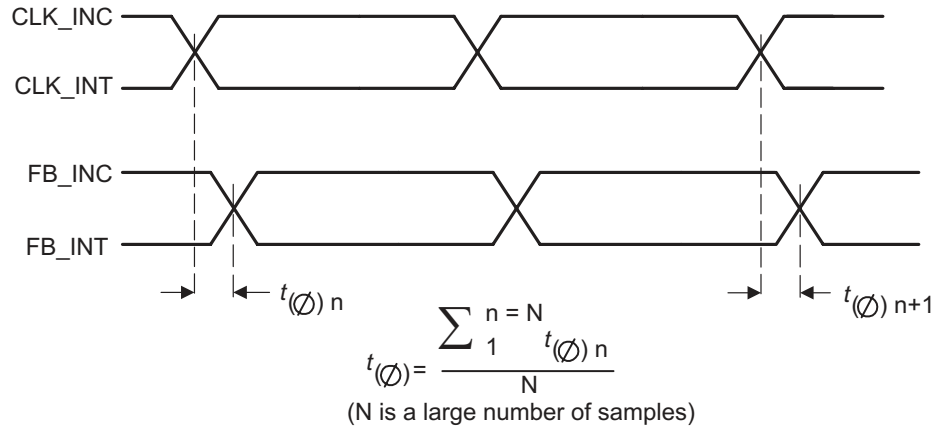

Figure 4. Static Phase Offset

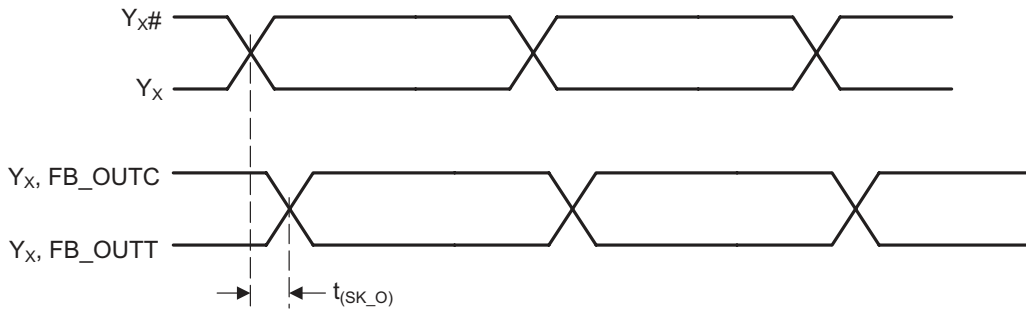

Figure 5. Output Skew

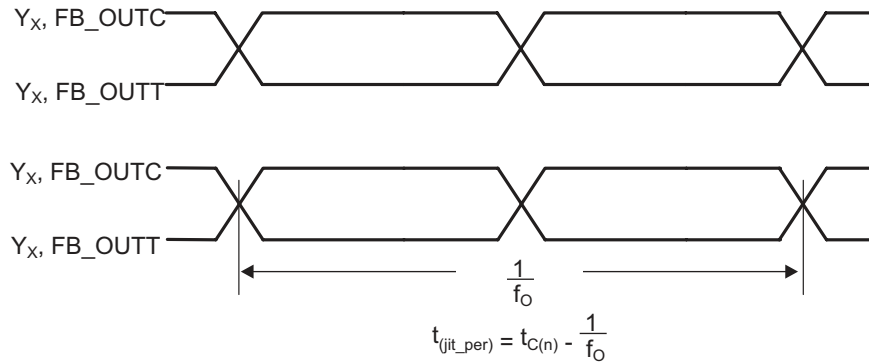

Figure 6. Period Jitter

Parameter Measurement Information

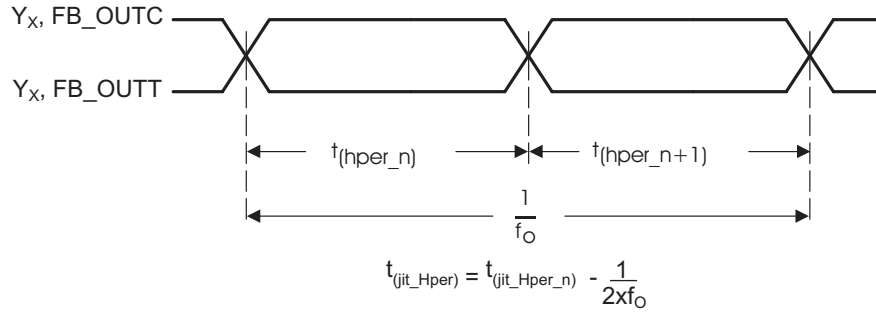
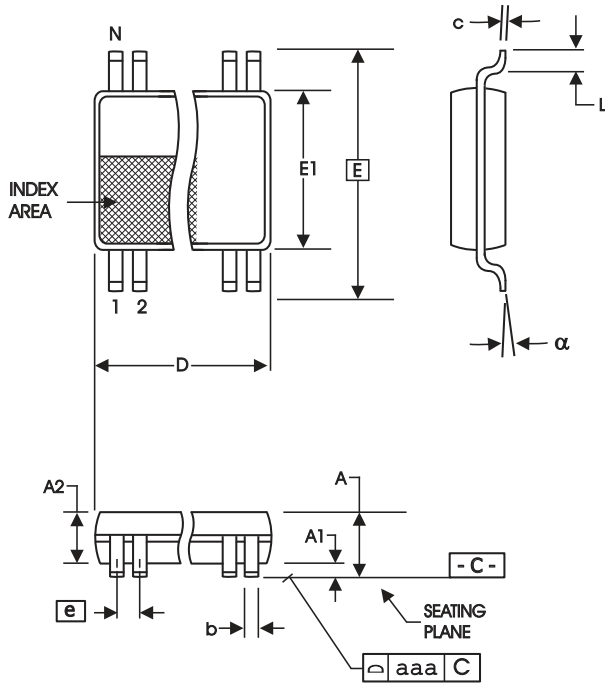

Figure 7. Half-Period Jitter



Figure 8. Input and Output Slew Rates



SYMBOL	In Millimeters		In Inches	
	COMMON DIMENSIONS	COMMON DIMENSIONS	COMMON DIMENSIONS	COMMON DIMENSIONS
	MIN	MAX	MIN	MAX
A	--	1.20	--	.047
A1	0.05	0.15	.002	.006
A2	0.80	1.05	.032	.041
b	0.17	0.27	.007	.011
c	0.09	0.20	.0035	.008
D	SEE VARIATIONS		SEE VARIATIONS	
E	8.10 BASIC		0.319 BASIC	
E1	6.00	6.20	.236	.244
e	0.50 BASIC		0.020 BASIC	
L	0.45	0.75	.018	.030
N	SEE VARIATIONS		SEE VARIATIONS	
a	0°	8°	0°	8°
aaa	--	0.10	--	.004

VARIATIONS

N	D mm.		D (inch)	
	MIN	MAX	MIN	MAX
48	12.40	12.60	.488	.496

Reference Doc.: JEDEC Publication 95, M O-163

10-0039

6.10 mm. Body, 0.50 mm. pitch TSSOP  
(240 mil) (20 mil)

## Ordering Information

ICS91857yGLFT

Example:

ICS XXXX y G - PPP - LF - T

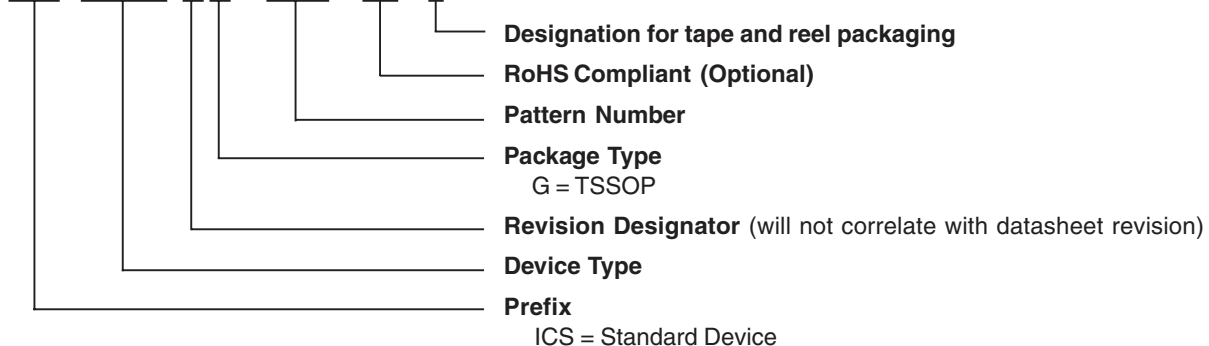

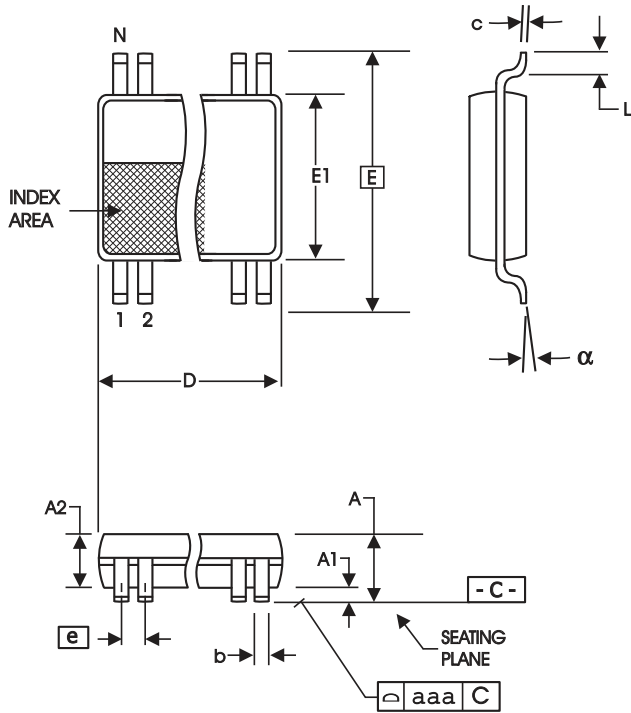

SYMBOL	In Millimeters		In Inches	
	COMMON DIMENSIONS	COMMON DIMENSIONS	COMMON DIMENSIONS	COMMON DIMENSIONS
	MIN	MAX	MIN	MAX
A	--	1.20	--	.047
A1	0.05	0.15	.002	.006
A2	0.80	1.05	.032	.041
b	0.13	0.23	.005	.009
c	0.09	0.20	.0035	.008
D	SEE VARIATIONS		SEE VARIATIONS	
E	6.40 BASIC		0.252 BASIC	
E1	4.30	4.50	.169	.177
e	0.40 BASIC		0.016 BASIC	
L	0.45	0.75	.018	.030
N	SEE VARIATIONS		SEE VARIATIONS	
a	0°	8°	0°	8°
aaa	--	0.08	--	.003

VARIATIONS

N	D mm.		D (inch)	
	MIN	MAX	MIN	MAX
48	9.60	9.80	.378	.386

Reference Doc.: JEDEC Publication 95, M O-153  
10-0037

4.40 mm. Body, 0.40 mm. pitch TSSOP (TVSOP)  
(173 mil) (16 mil)

Ordering Information

ICS91857yLLFT

Example:

ICS XXXX y L - PPP - LF - T

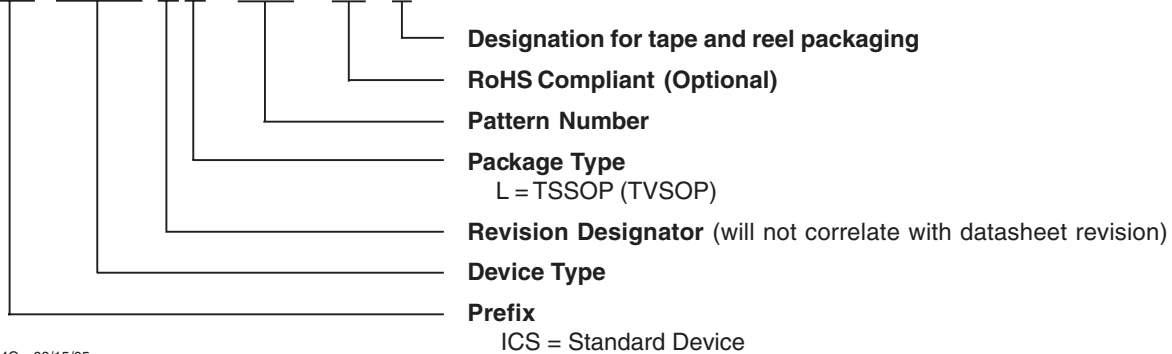

**Revision History**

<b>Rev.</b>	<b>Issue Date</b>	<b>Description</b>	<b>Page #</b>
C	8/15/2005	Added LF Ordering Information.	12-13

## IMPORTANT NOTICE AND DISCLAIMER

RENESAS ELECTRONICS CORPORATION AND ITS SUBSIDIARIES (“RENESAS”) PROVIDES TECHNICAL SPECIFICATIONS AND RELIABILITY DATA (INCLUDING DATASHEETS), DESIGN RESOURCES (INCLUDING REFERENCE DESIGNS), APPLICATION OR OTHER DESIGN ADVICE, WEB TOOLS, SAFETY INFORMATION, AND OTHER RESOURCES “AS IS” AND WITH ALL FAULTS, AND DISCLAIMS ALL WARRANTIES, EXPRESS OR IMPLIED, INCLUDING, WITHOUT LIMITATION, ANY IMPLIED WARRANTIES OF MERCHANTABILITY, FITNESS FOR A PARTICULAR PURPOSE, OR NON-INFRINGEMENT OF THIRD PARTY INTELLECTUAL PROPERTY RIGHTS.

These resources are intended for developers skilled in the art designing with Renesas products. You are solely responsible for (1) selecting the appropriate products for your application, (2) designing, validating, and testing your application, and (3) ensuring your application meets applicable standards, and any other safety, security, or other requirements. These resources are subject to change without notice. Renesas grants you permission to use these resources only for development of an application that uses Renesas products. Other reproduction or use of these resources is strictly prohibited. No license is granted to any other Renesas intellectual property or to any third party intellectual property. Renesas disclaims responsibility for, and you will fully indemnify Renesas and its representatives against, any claims, damages, costs, losses, or liabilities arising out of your use of these resources. Renesas' products are provided only subject to Renesas' Terms and Conditions of Sale or other applicable terms agreed to in writing. No use of any Renesas resources expands or otherwise alters any applicable warranties or warranty disclaimers for these products.

(Disclaimer Rev.1.0 Mar 2020)

### Corporate Headquarters

TOYOSU FORESIA, 3-2-24 Toyosu,  
Koto-ku, Tokyo 135-0061, Japan  
[www.renesas.com](http://www.renesas.com)

### Contact Information

For further information on a product, technology, the most up-to-date version of a document, or your nearest sales office, please visit:  
[www.renesas.com/contact/](http://www.renesas.com/contact/)

### Trademarks

Renesas and the Renesas logo are trademarks of Renesas Electronics Corporation. All trademarks and registered trademarks are the property of their respective owners.