

Detailed Specification

Product Name : TOF Camera (Interior RGB/IR)

Serial Number : CDM-GCGC1ZA

Version : Ver.1.3

Date : Apr. 25th, 2016

Company Name : Panasonic Photo & Lighting Co., Ltd.

1-1 Saiwai-cho, Takatsuki City, Osaka 569-1193, Japan

© Panasonic Photo & Lighting Co., Ltd. 2016

This document is copyright and issued on the strict understanding that it is not to be reproduced, copied, or disclosed to any third party, either in whole or part, without the prior written consent of Panasonic Photo & Lighting Co., Ltd.

The information contained in this document and all right in any design disclosed therein, are and remain the exclusive property of Panasonic Photo & Lighting Co., Ltd

TOF Camera (Indoors, RGB/IR)

Changes History

Date	Ver	Items	Contents	Remarks
2016/4/25	1.0		First Version	
2016/12/5	1.3			

Table of Contents

Detailed Specification	1
1. Overview.....	4
1.1 Application scope.....	4
1.1.1 Product Specification	4
1.2 Overall diagram and functions list	6
1.2.1 Connections Schematics.....	6
1.2.2 Functions list.....	7
2. Hardware specifications.....	8
2.1 Overall diagram.....	8
2.1.1 External shape diagram	8
2.1.2 Functions terminal.....	9
2.1.3 Exterior functional position.....	11
2.2 Data Format.....	13
2.2.1 Paralel 36bit	13
2.2.2 Paralel 16bit	16
2.2.3 Paralel 14bit	18
2.3 Serial Communication.....	20
2.3.1 I2C Communication Spec	20
2.4 Pins Processing.....	21
2.4.1 Pins processing.....	21
2.4.2 Unused pins processing.....	21
3. Operation Sequence.....	22
3.1 State transition diagram.....	22
3.2 Startup sequence.....	23
3.3 Exit sequence	23
3.4 Error processing.....	24
4. Commands list	25
5. Others	30
5.1 Lot number.....	30
6. Important Notes.....	31
6.1 Safety Precautions.....	31
6.2 Usage Precautions	
6.2.1 Basic principles	31
6.2.2 Usage precautions	32
6.2.3 Static charge precautions.....	エラー! ブックマークが定義されていません。
6.2.4 Cleaning	32
6.2.5 Storage	32
6.3 Laser Safety.....	33
6.4 EMI	33
6.5 Special Items	34

1. Overview

1.1 Application scope

This specification applies for indoors TOF camera VGA-RGB shooting.

1.1.1 Product Specification

- Image sensor
 - Type: Color combination type CCD sensor (MN34903TLJ5Z@Panasonic)
 - Pixel number: VGA
 - Size: 1/4" (5.6 μ m \times 5.6 μ m)
- Lens specification
 - Focal distance: 3.66mm \pm 3%
 - F: 1.3 \pm 5%
 - Distortion: min -8.1%, typ -5.1%, max -2.1% (Horizontal edge)
 - Angle of view: Diagonal 67.1°, Horizontal 54.6°, Perpendicular 41.4° each \pm 3%
 - Resolution: Center/Peripheral (0.7H) : above 160TV (@800mm)
- Camera focus position
 - Focus adjustment rate: \sim 800mm (@RGB)
 - Recommended shooting range RGB: \sim 400mm - 5000mm
- Light emitting part
 - Light source: Semiconductor Laser 4 light
 - Wave length: 855nm (typ)
 - Dispersion angle: Horizontal: above 54.6°, Vertical: above 41.4
 - Safety: Class 1 Laser product (IEC60825-1, JIS C 6802 compliant)
 - Light emitting strength: Rated 5600 (Register setting value)
- Image distance specification
 - Shooting distance range
 - Computational Power Limit: 100mm \sim 13200mm
 - ※ This is the setting range, it does not guarantee performance
 - Recommended practical range: 100mm \sim approx 6000mm
 - ※ Depends on various conditions as reflection rate, required accuracy and so on
 - Distance repeatability: shooting range 1000mm, \pm 50mm (Center pixel)
 - Distance accuracy: shooting range 1000m, standard deviation under 26mm (Center pixel)
 - Distance resolution: 1mm (distance range until 2500mm) \sim 2mm (distance range until 13200mm)
 - In-plane resolution: more than 60TV
- Output format
 - Data format
 - 1) Parallel 36bit (Depth/IR24bit, RGB12bit Data line separation)
 - 2) Parallel 16bit (Depth/IR/RGB 16bit same data line)

3) Parallel 14bit (Depth/IR/RGB 14bit same data line+2bit synchronized signal)

※ For details please refer to 「1.2.1 Connection Scheme」, 「2.2 Data format」

- Image size
Depth: 320x240, IR: 320x240, RGB: 640x480
- Standard Clock
 - 1) 45MHz@parallel 36bit
 - 2) 90MHz@parallel 16bit, parallel 14bit
- Signal level common with CMOS 3.3V
- RGB output in Bayer format
- Frame rate
 - 23.5fps ±0.1
- External communication specification
 - I2C (Signal speed: 100kHz)
 - Signal level: 3.3V (pulled up on the camera board)
 - Signal level: absolute maximum range: -0.3V ~ 3.6V
- External dimensions
 - H66mm×W100mm×D24mm (Excluding protrusions)
※ Detailed dimensions please refer to 2.1.1
- Weight
 - less than 150g
- Average current
 - In operation (rated emission intensity): 1020mA (typ)
 - In standby: 215mA (typ)
- Power supply
 - Recommended 5V (Tolerance±5%, ripple factor 100mVp-p under), 4A power
 - Absolute maximum ratings: +0 ~ +5.5V
 - Current capacitance: min 3A
- Guaranteed operating temperature (at rated light emission intensity)
 - 0°C ~ +40°C (surrounding environment temperature)
 - Camera position: Upright (upper and lower openings in vertical position)
 - Camera stand-alone (the camera is not in a fixed enclosure)
 - ※ For heat dissipation design please refer to 2.1.4(2) for cases when camera is enclosed or not in upright design
- Storage temperature range
 - -40°C ~ +85°C
- Ambient illuminance
 - Please refer to section 6.2

1.2 Overall diagram and functions list

1.2.1 Connections Schematics

The following drawing shows the camera:

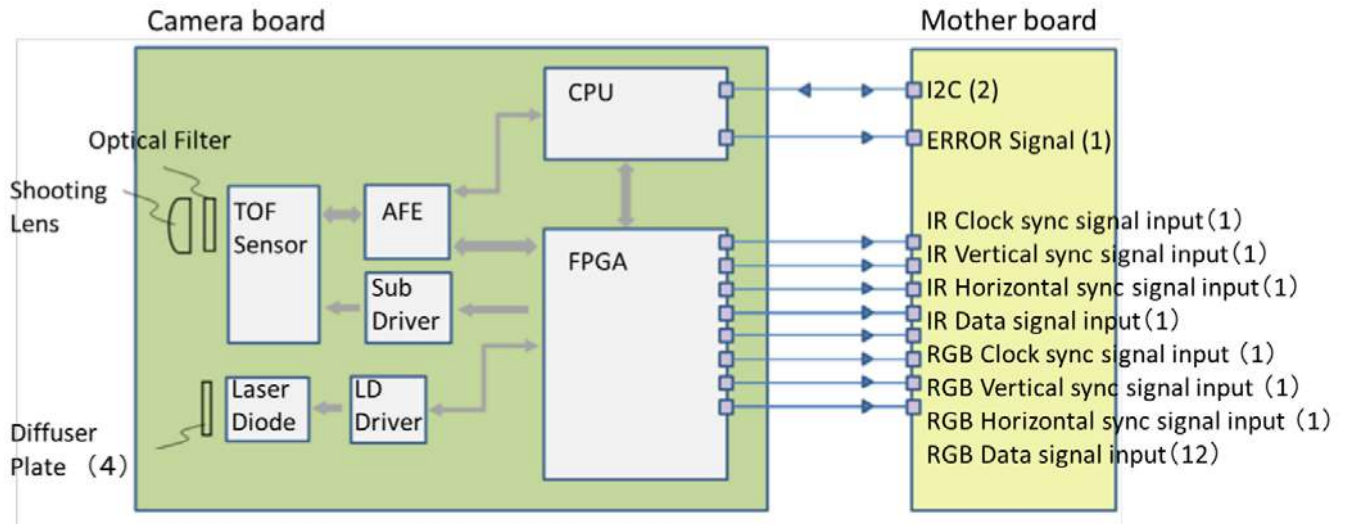

The FPGA outputs the RGB Data and the IR Data.

The IR data outputs the image distance data (the below Depth Data) in 16bit and the IR data in 8bit.

※ The IR data is the image at the light source emission

Also, the IR data outputs an IR synchronized signal for

IR/Depth Clock synchronization signal (IMG_DAT_FCK)

IR/Depth VD vertical synchronization signal (IMG_DAT_VD_SYC)

IR/Depth HD horizontal synchronization signal (IMG_DAT_HD_SYC)

RGB data outputs the RGB data in 12bits. Also, RGB data outputs the following signals ,

RGB Clock synchronization signal (IMG_CDAT_FCK)

RGB VD VD vertical synchronization signal (IMG_DAT_VD_SYC)

RGB HD HD horizontal synchronization signal (IMG_DAT_HD_SYC)

The communication with the TOF camera is done via I2C. In this case, the TOF camera operates as a slave.

The ERROR signal terminal conveys malfunctions from the TOF camera to the motherboard.

1.2.2 Functions list

Please refer to the below functions list.

① Video data output

Depth data, IR data, RGB data are transmitted to the motherboard as digital parallel signals.

The Clock, VD, HD signals are transmitted as synchronized signals.

- a) Depth data (16bit), IR data (8bit)
- b) RGB data (12bit)

② Malfunction detection

When the TOF camera malfunctions, the ERROR signal becomes low and the abnormality is transmitted to the motherboard.

ERROR Signal: High: normal operation, Low: malfunction

The malfunction detection happens under the following conditions

- The TOF camera does not start (Device init error)
- The camera data is not transmitted (No signal error)
- The camera temperature is abnormal (Temp over error)

③ Temperature feedback function

This function compensates for the gap in the Depth Data due to the change in camera temperature.

④ Serial communication function

The camera communication protocol is I2C. The TOF camera operates as a slave.

It is possible to change the camera state, settings, controls, setting values readings.

⑤ Parameters hold function

The camera saves the parameters set by the user.

At start-up these parameters are used.

*the guaranteed parameters rewrite: 100,000 times

⑥ Noise reduction

The noise is reduced by using filter processing for the IR data and depth data.

⑦ IR-AE (IR Automatic Exposure Control)

In order to optimize the brightness value of the IR data, the light intensity of each frame is automatically changed.

⑧ RGB-AE (RGB Automatic Exposure Control)

In order to optimize the brightness value of the RGB data, the digital gain and the exposure time are automatically changed.

While flicker countermeasures are effective under normal circumstances, they are not useful when the brightness in a certain environment is higher.

2. Hardware specifications

2.1 Overall diagram

2.1.1 External shape diagram

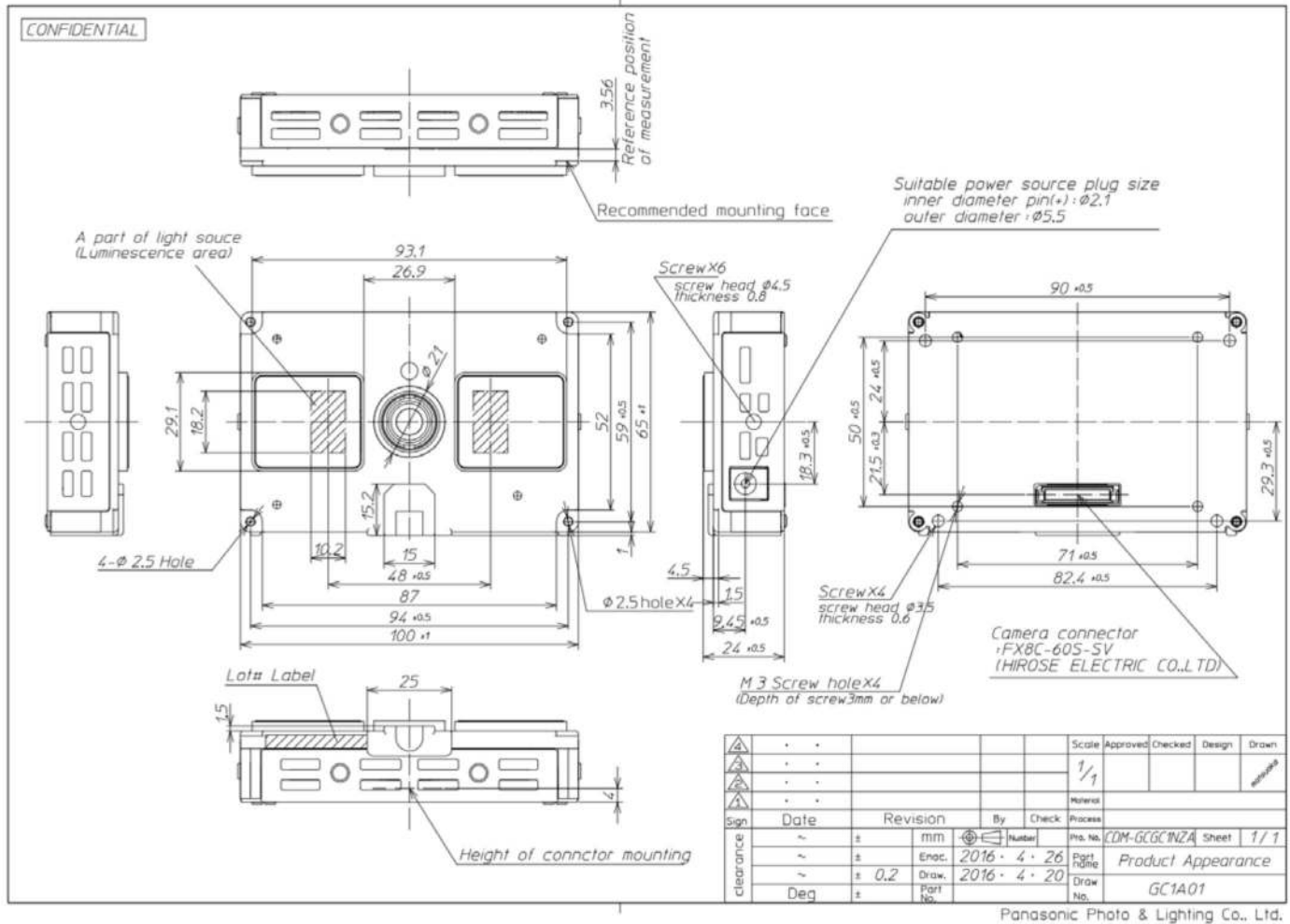

※ The evaluation sample can have a tripod.

2.1.2 Functions Terminal

The table below shows the pin arrangement of the camera connectors.

Camera Connectors (FX8C-60S-SV)		Contents	Camera Connectors (FX8C-60S-SV)		Contents
Pin No.	Pin Name		Pin No.	Pin Name	
1	IMG_5V	+5V Power Note: Camera Power Supply Input	2	GND	GND
3	IMG_5V		4	GND	
5	IMG_5V		6	GND	
7	IMG_5V		8	GND	
9	IMG_5V		10	GND	
11	IMG_5V		12	GND	
13	TEST	※Unused	14	IMG_DAT[23]	IR/Depth data signal output
15	IMG_CDAT_HD_SYNC	RGB HD horizontal sync signal output	16	IMG_DAT[22]	IR/Depth data signal output
17	IMG_CDAT_VD_SYNC	RGB VD vertical sync signal output	18	IMG_DAT[21]	IR/Depth data signal output
19	IMG_CDAT_FCK	RGB clock sync signal output	20	IMG_DAT[20]	IR/Depth data signal output
21	IMG_CDAT_[11]	RGB image data signal output	22	IMG_DAT[19]	IR/Depth data signal output
23	IMG_CDAT_[10]	RGB image data signal output	24	IMG_DAT[18]	IR/Depth data signal output
25	IMG_CDAT_[9]	RGB image data signal output	26	IMG_DAT[17]	IR/Depth data signal output
27	IMG_CDAT_[8]	RGB image data signal output	28	IMG_DAT[16]	IR/Depth data signal output
29	IMG_CDAT_[7]	RGB image data signal output	30	IMG_DAT[15]	IR/Depth data signal output
31	IMG_CDAT_[6]	RGB image data signal output	32	IMG_DAT[14]	IR/Depth data signal output
33	IMG_CDAT_[5]	RGB image data signal output	34	IMG_DAT[13]	IR/Depth data signal output
35	IMG_CDAT_[4]	RGB image data signal output	36	IMG_DAT[12]	IR/Depth data signal output
37	IMG_CDAT_[3]	RGB image data signal output	38	IMG_DAT[11]	IR/Depth data signal output
39	IMG_CDAT_[2]	RGB image data signal output	40	IMG_DAT[10]	IR/Depth data signal output
41	IMG_CDAT_[1]	RGB image data signal output	42	IMG_DAT[9]	IR/Depth data signal output
43	IMG_CDAT_[0]	RGB image data signal output (※least significant bit)	44	IMG_DAT[8]	IR/Depth data signal output
45	ERROR	Abnormality detection ERROR signal output	46	IMG_DAT[7]	IR/Depth data signal output
47	SDA	I2C data signal input/output	48	IMG_DAT[6]	IR/Depth data signal output
49	SCL	I2C clock signal input	50	IMG_DAT[5]	IR/Depth data signal output
51	IMG_DAT_HD_SYNC	IR/Depth HD horizontal sync signal output	52	IMG_DAT[4]	IR/Depth data signal output
53	IMG_DAT_VD_SYNC	IR/Depth VD vertical sync signal output	54	IMG_DAT[3]	IR/Depth data signal output
55	IMG_DAT_FCK	IR/Depth clock sync signal output	56	IMG_DAT[2]	IR/Depth data signal output
57	UART16	For UART TX※unused	58	IMG_DAT[1]	IR/Depth data signal output
59	UART14	For UART RX※unused	60	IMG_DAT[0]	IR/Depth data signal output (※lower bit)

Connectors

TOF Camera connectors FX8C-60S-SV (HIROSE ELECTRIC CO.LTD)

Applicable connectors FX8C-60P-SV * (HIROSE ELECTRIC CO.LTD)

※The user has to use connectors compatible with the above connectors for the motherboard.

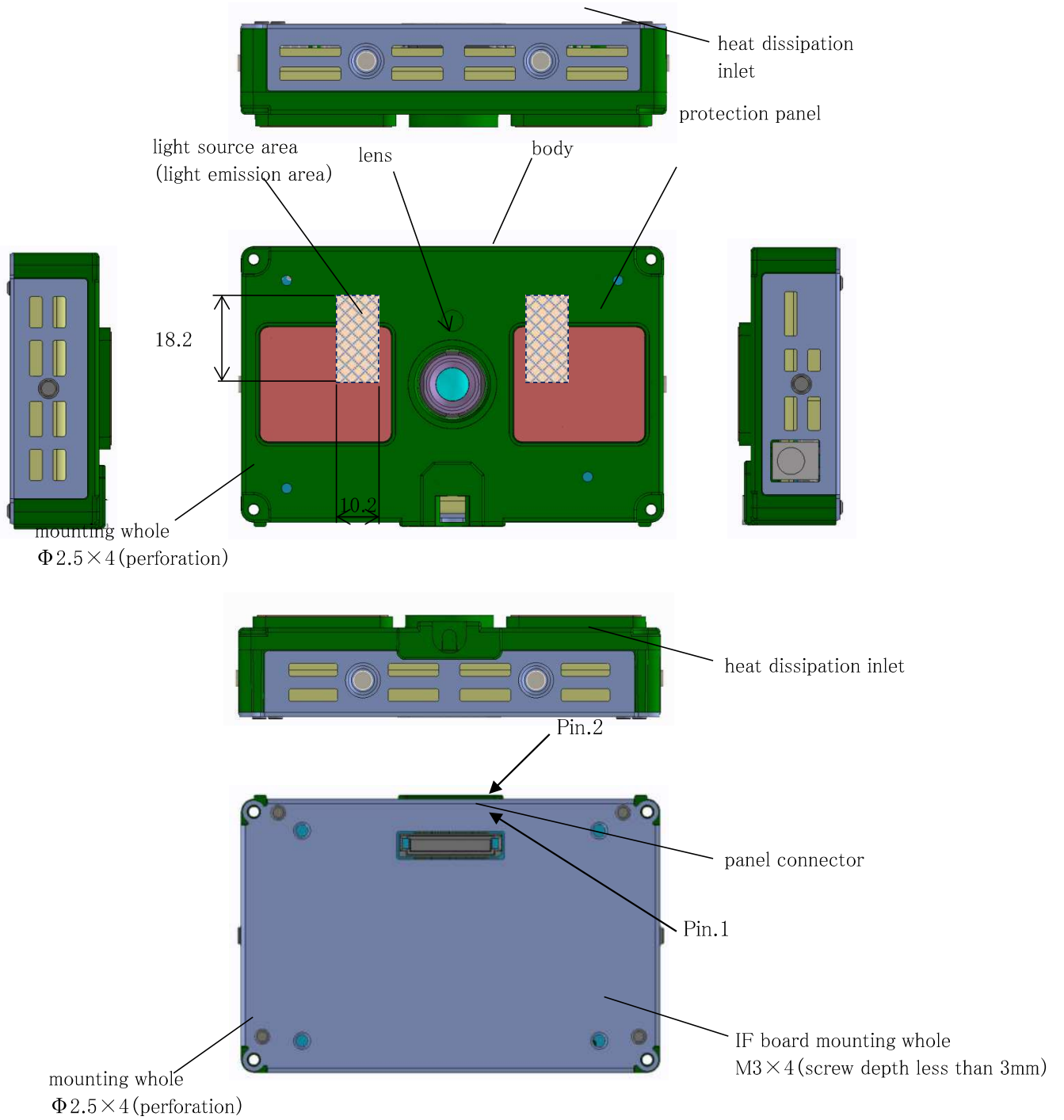

2.1.3 Exterior functional position

① Opening design

- The protective panel and the lens have the following dimensions.
- Refer to the previous section for the light emitting area of the protective panel

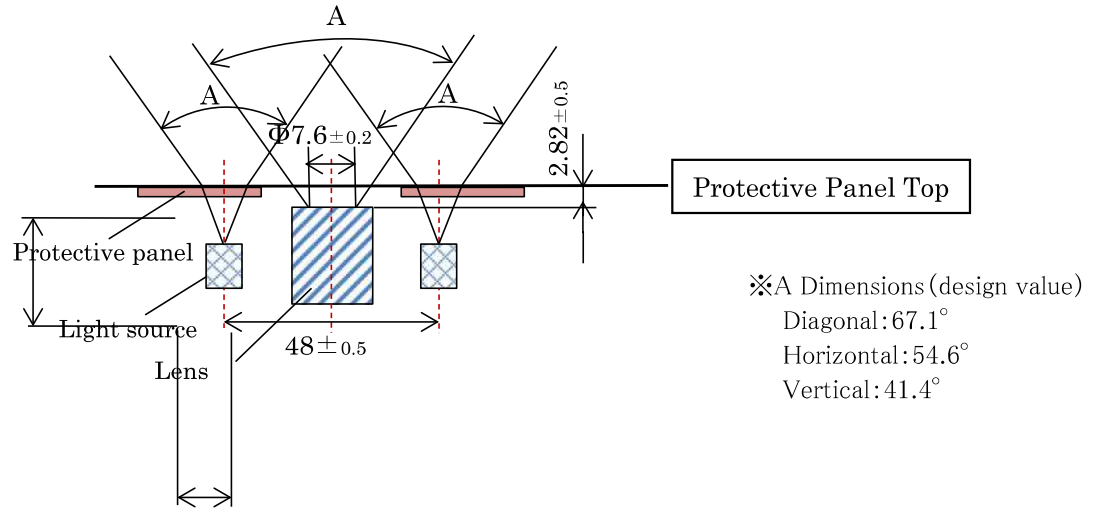

※ Since the angle of view is based on these values, please allow for extra space when you install an additional panel

※ There is the risk of halation or light attenuation in case another panel is installed in front of the protective panel or in front of the lens

※ The irradiation light from the light source is diffusing slightly even outside the viewing angle in the figure above. Please check the performance in actual use conditions, since errors may occur in the measured distance. When an opening is provided in front of the camera, irradiation light hits and halation occurs.

Please refer to the example below and design when setting up protective panel for the camera:

- Position: Keep it close to the front of the camera.
- Materials and colors: black type materials, especially those which do not easily reflect near infrared light, are desirable.
- Shape: make the cross section of the opening thin and edge shape.
- Surface condition: anti-reflection surface by matte treatment should be used.

② Heat radiation design

- When installing the camera and covering it with another part, consideration should be given to ventilation, so that the heat does not stay inside. Please provide ventilation openings.
- Please do not block the openings on the upper and lower surfaces of the camera since they are intake and exhaust ports for heat radiation.
- Also, if the left, right sides and the back side are blocked from outside air, the heat dissipation properties may decrease.
- While the camera is in operation, please take measures to dissipate heat so that the internal temperature of the camera is 60°C or less. (At ambient temperature of 25°C)
- Refer to the value of "Local Address 494 A" in "4. Command List" for the camera internal temperature.)

③ Recommended installation

<Camera body installation>

- The camera can be fixed using the through holes at the four corners of the front and back of the body.
- Refer to the external drawing for fixing hole position.
- Hole size : $\Phi 2.5$.
- Reference screw size
 - Tapping screw nominal diameter $\phi 3$
 - M screw less than M2.5

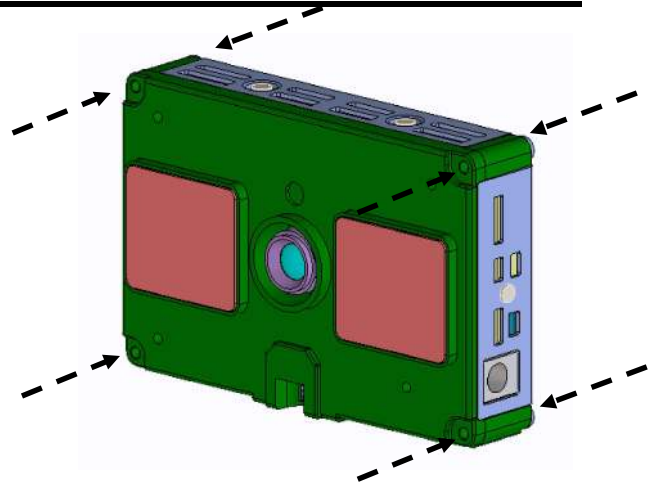

<Board installation>

- Please use a spacer, screws etc. that match the height of the connector in order to prevent unstable connections
 - Please refer to 2.1.1 for the fixed holes positions
 - Recommended screw size : M3 (screw height : less than 3mm for the shield, effective screw depth 2mm)
- ※ Please do not use screws longer than the recommended length as it might result in shorting with the Internal board.

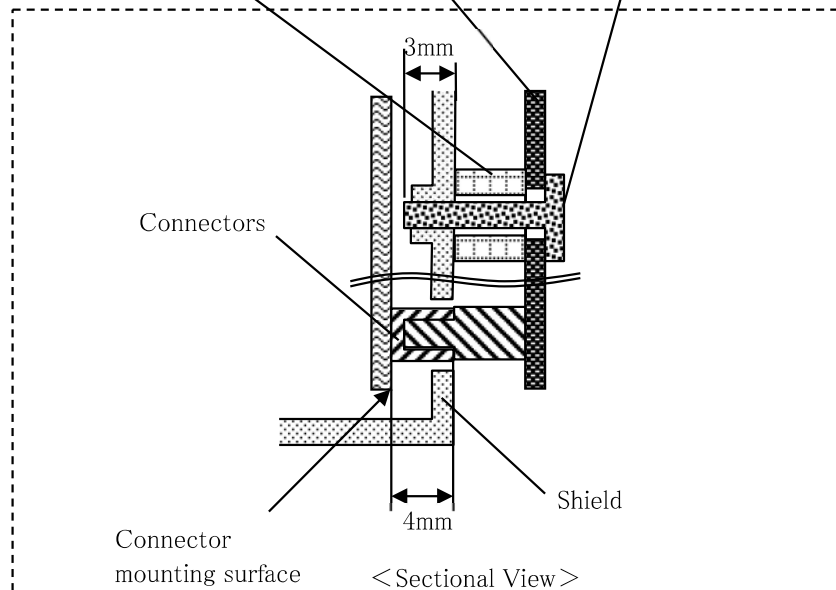
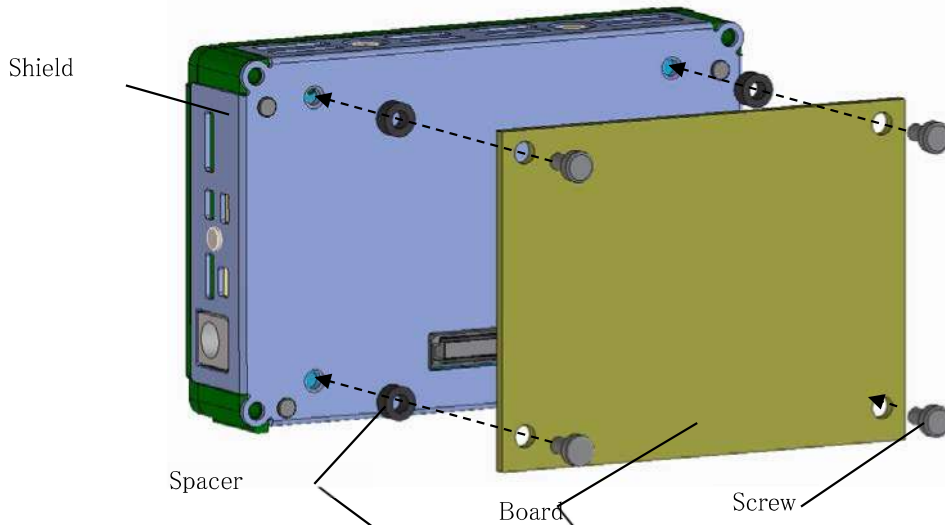

2.2 Data Format

2.2.1 Parallel 36bit

This format separates the Depth/IR and RGB data format, the Depth/IR is processed on a 24bit, RGB is processed on a 12bit data line.

The sync signal (VD, HD) is common for the Depth/IR while the sync signal for RGB is processed on a separate line.

The clock works at 45MHz, the Depth/IR and RGB have a separate signal/

Depth Output: IMG_DAT[15:0] + IMG_DAT_VD_SYNC + IMG_DAT_HD_SYNC

IR Output: :IMG_DAT[23:16] + IMG_DAT_VD_SYNC + IMG_DAT_HD_SYNC

RGB Output :IMG_CDAT[11:0] + IMG_CDAT_VD_SYNC + IMG_CDAT_HD_SYNC

(1) Depth/IR + RGB Output Timing

- Depth/IR Data and RGB Data use an alternate frame

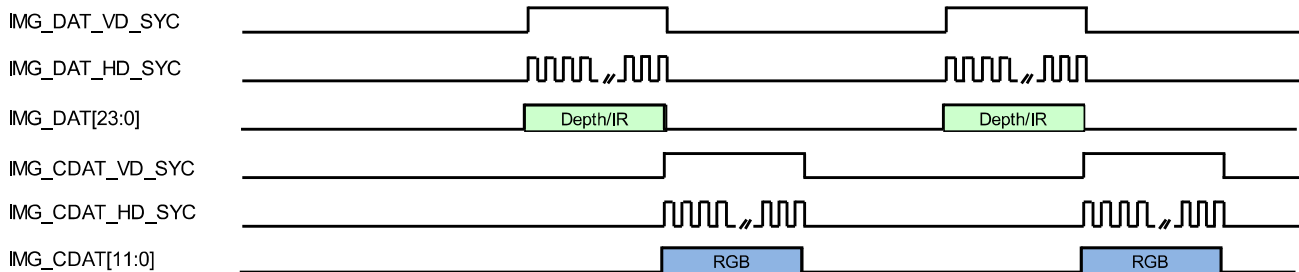

(2) Output Format

Depth/IR Output

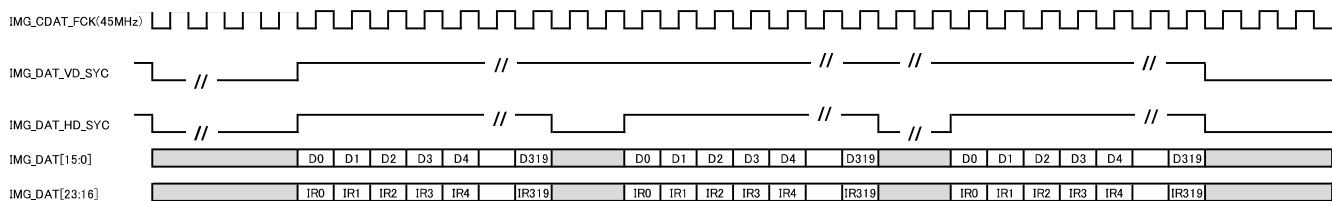

RGB Output

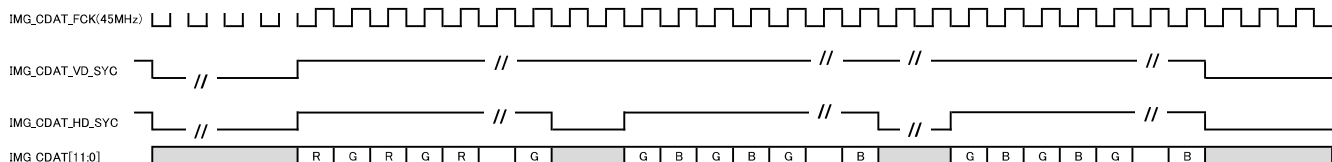

(3) Depth/IR Data Output

- Depth Data is represented on 16bits Depth (0,0)~Depth (Xcnt-1, Ycnt-1).
- IR Data is represented on 8bits IR (0,0)~IR (Xcnt-1, Ycnt-1).
- Depth Data and IR Data have a simultaneous output on 24 pixels with the target pixel position aligned.

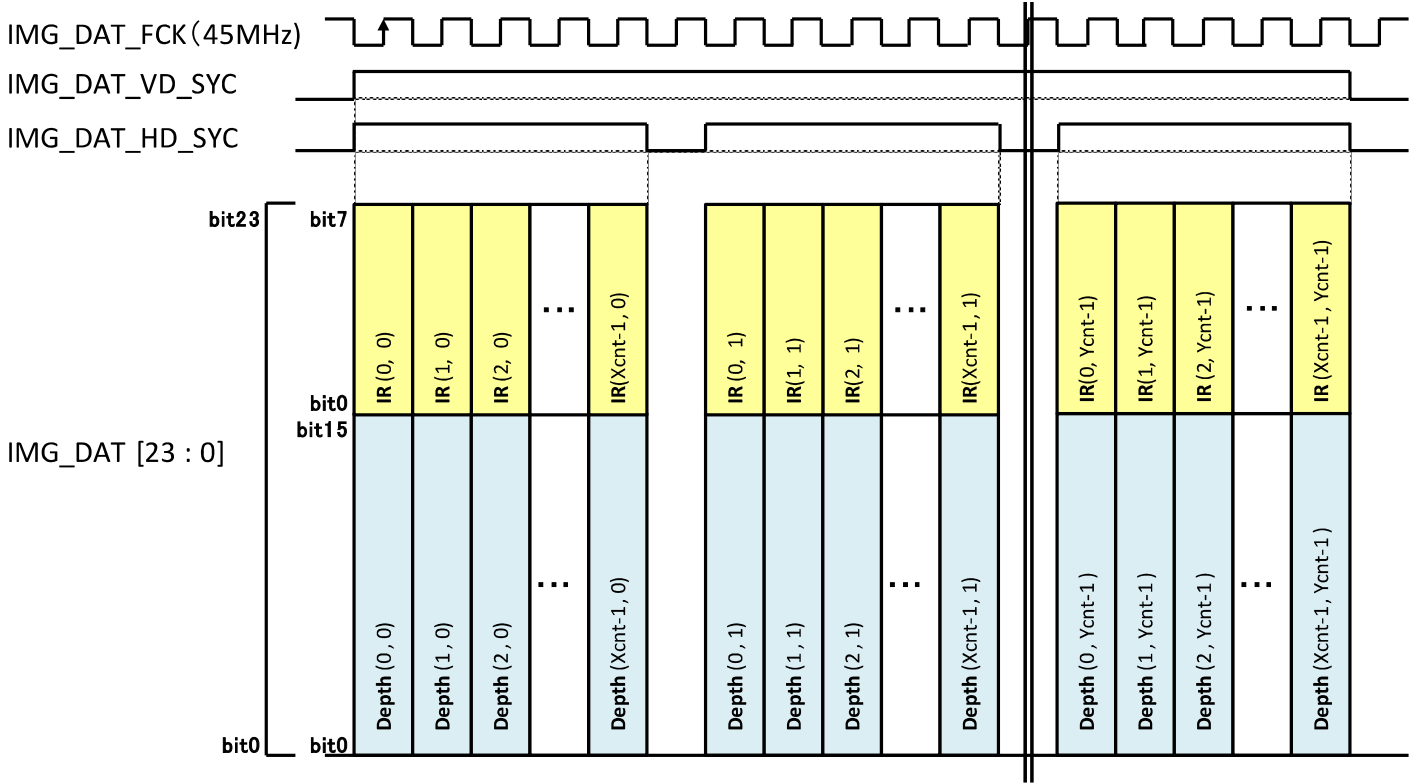

(0,0)	(1,0)	(2,0)	(Xcnt-1,0)
(0,1)	(1,1)	(2,1)	(Xcnt-1,1)
(0,2)	(1,2)	(2,2)	(Xcnt-1,2)
...					
(0,Ycnt-1)	(1,Ycnt-1)	(2,Ycnt-1)			(Xcnt-1,Ycnt-1)

Pixel Address Data Image

(4) RGB Data Output

- The RGB data is represented on 12 bits Bayer_R(0,0)~Bayer_B(Xcnt-1, Ycnt-1)

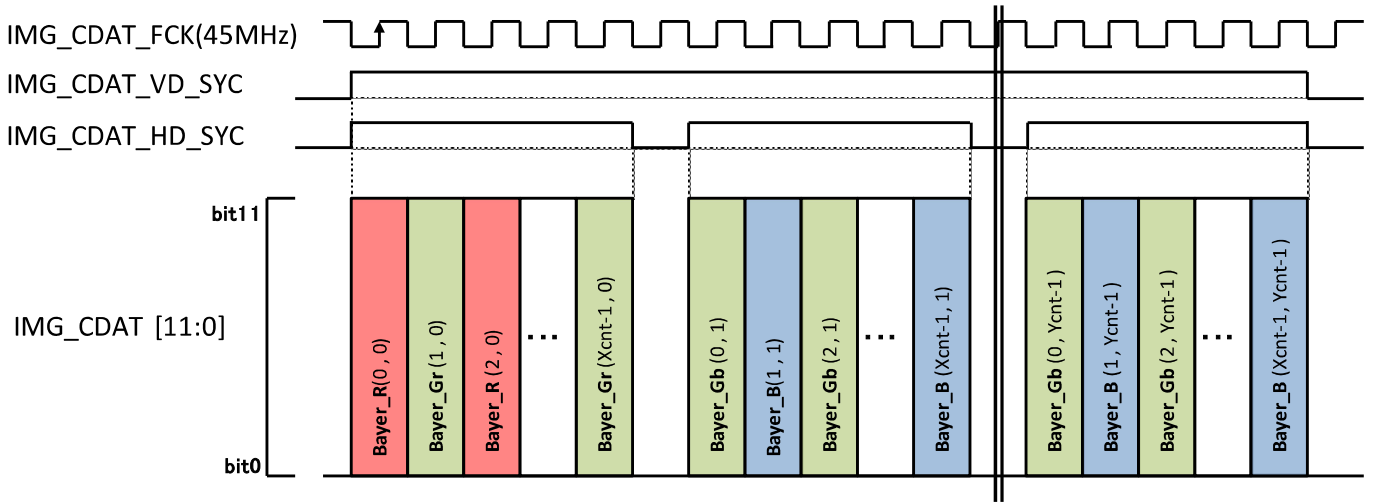

(0,0)	(1,0)	(2,0)	(Xcnt-1,0)
(0,1)	(1,1)	(2,1)	(Xcnt-1,1)
(0,2)	(1,2)	(2,2)	(Xcnt-1,2)
⋮					
(0,Ycnt-1)	(1,Ycnt-1)	(2,Ycnt-1)			(Xcnt-1,Ycnt-1)

Pixel Address Data Image

2.2.2 Parallel 16bit

Depth/IR and RGB are processed on the same data line, Depth/IR/RGB is processed on a 16bit line.

The sync signal (VD, HD) is common for Depth/IR/RGB.

The clock operates at 90MHz for Depth/IR/RGB.

Depth Output: $IMG_DAT[15:0] + IMG_DAT_VD_SYNC + IMG_DAT_HD_SYNC$

IR Output : $IMG_DAT[7:0] + IMG_DAT_VD_SYNC + IMG_DAT_HD_SYNC$

RGB Output : $IMG_DAT[11:0] + IMG_DAT_VD_SYNC + IMG_DAT_HD_SYNC$

(1) Depth/IR/RGB Output Timing

- Depth/IR data and RGB data output as alternate frames.

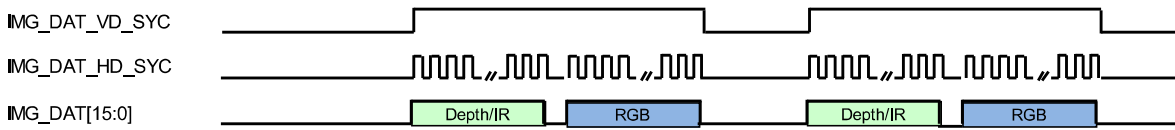

(2) Depth/IR/RGB Output Format

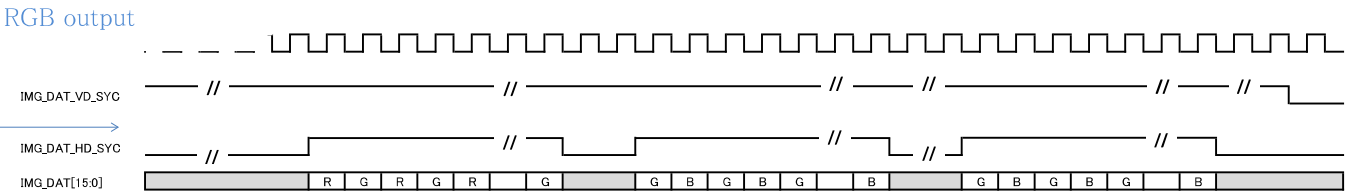
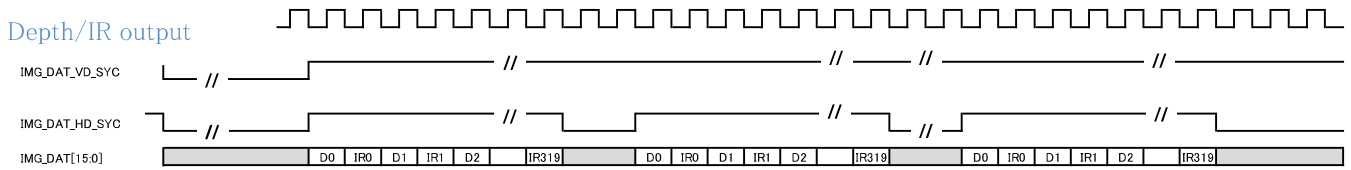

(3) Depth/IR Data and RGB Data Output

- Depth Data 16bit is represented on 16bits Depth(0,0)~Depth(Xcnt-1, Ycnt-1).
- IR Data is represented on 8 bits IR(0,0)~IR(Xcnt-1, Ycnt-1).
- Depth Data and IR data are represented on 16bits as an alternate output.
- Depth /IR Data and RGB Data have a continuous output
- RGB data is represented on 12 bits Bayer_R(0,0)~Bayer_B(Xcnt-1, Ycnt-1)

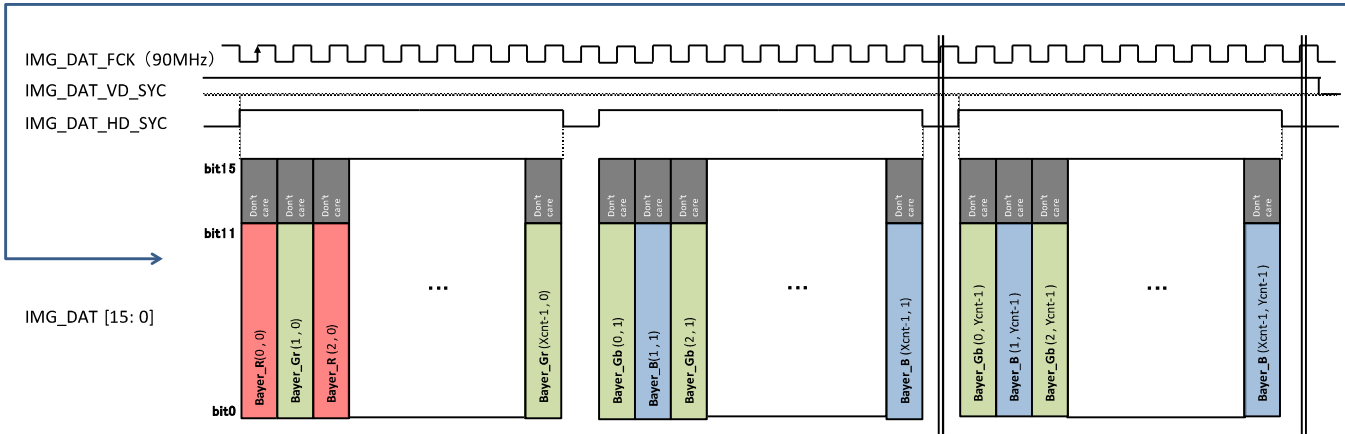
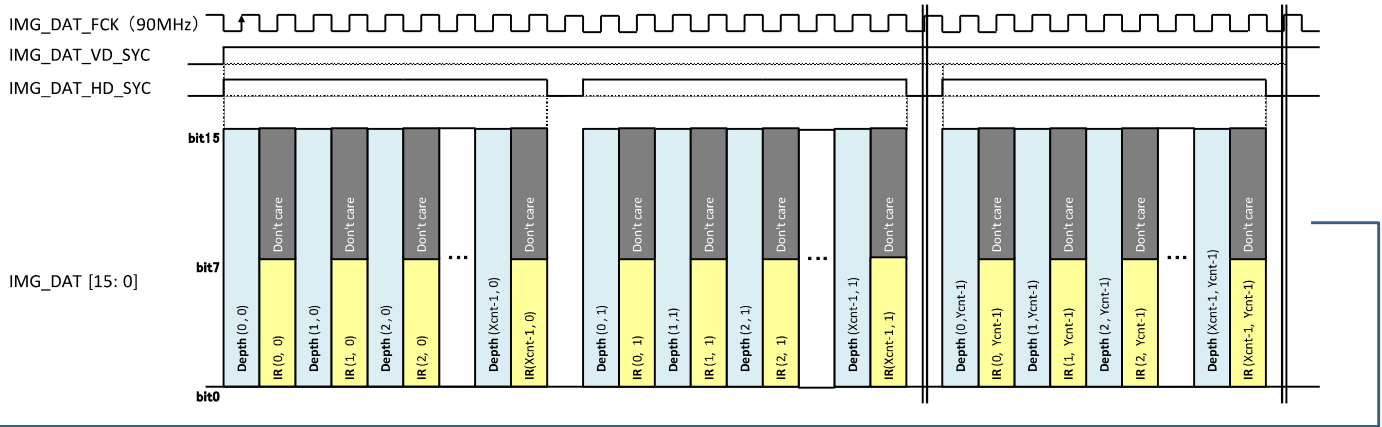

2.2.3 Parallel 14bit

Depth/IR/RGB + VDSYC/HD_SYNC have an embedded data format.

Depth/IR and RGB are processed on the same data line, Depth/IR/RGB are processed on the same 14bit line.

The upper 2 bits of the 16bits data output are HD and VD.

The embedded VD, HD are processed at the same time with the separately processed IMG_DAT_VD_SYNC, IMG_DAT_HD_SYNC.

The clock works at 90MHz for both Depth/IR/RGB.

- Depth Output : IMG_DAT[13:0](Data) + IMG_DAT[15:14](VD,HD)
+ IMG_DAT_VD_SYNC + IMG_DAT_HD_SYNC
- IR Output : IMG_DAT[7:0] (Data) + IMG_DAT[15:14](VD,HD)
+ IMG_DAT_VD_SYNC + IMG_DAT_HD_SYNC
- RGB Output : IMG_DAT[11:0] (Data) + IMG_DAT[15:14](VD,HD)
+ IMG_DAT_VD_SYNC + IMG_DAT_HD_SYNC

(1) Depth/IR/RGB Output Timing

- Depth/IR Data and RGB Data frames alternate

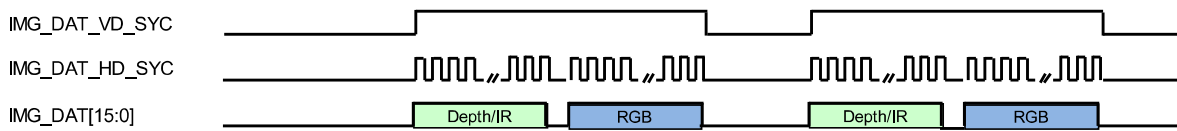

(2) Depth/IR/RGB Output Format

Depth/ IR Output

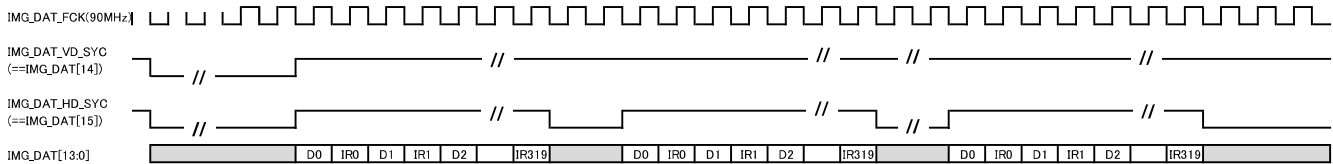

RGB Output

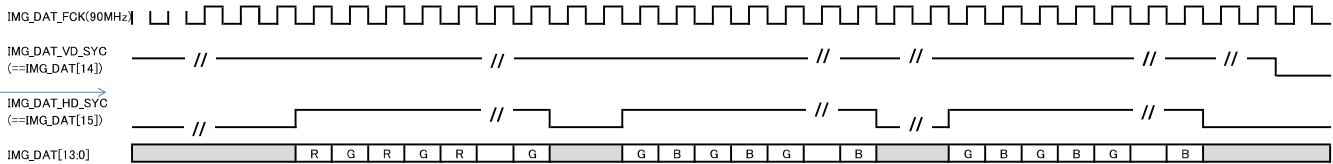

(3) Depth/IR Data and RGB Data Output

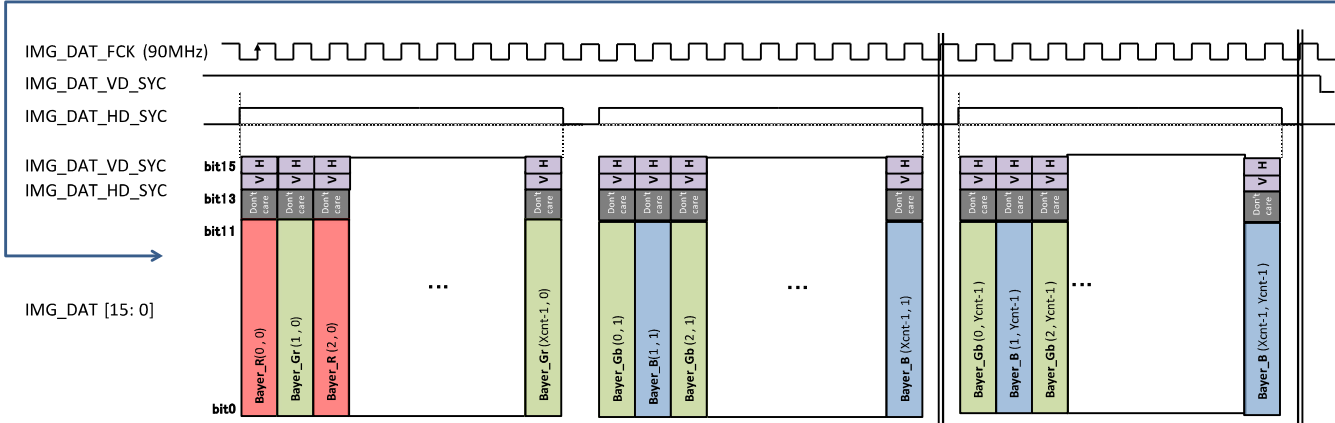
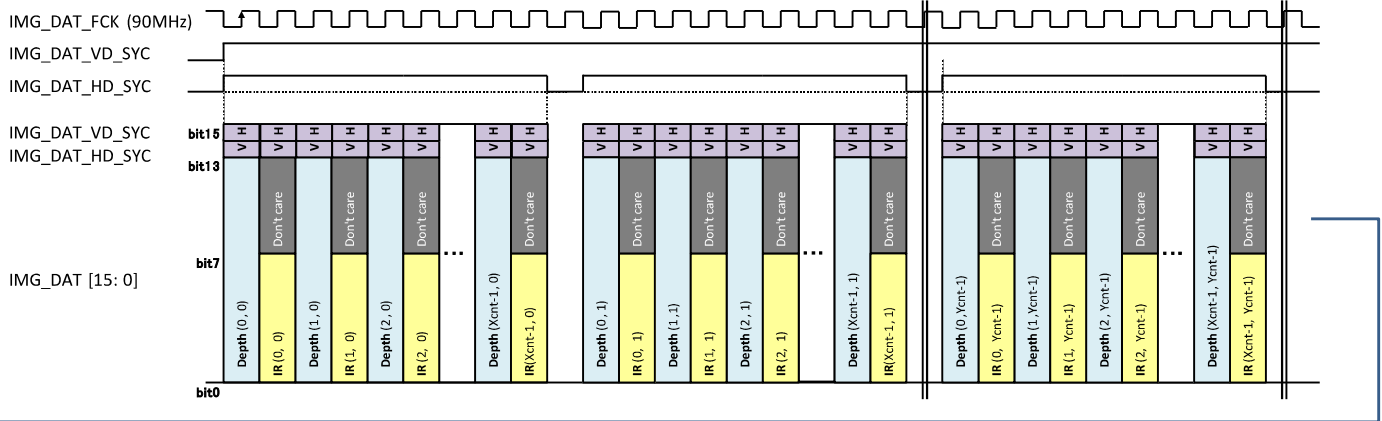

2.3 Serial Communication

The TOF camera communicates via I2C

(1) Communication Spec

The following represents the I2C communication. The TOF camera operates as a slave.

- The TOF camera operates as a slave

Item	Spec
Communication master	External device
Communication speed	Standard mode(100kHz)
Shift mode	MSB
Slave address	0xC2

a) Write

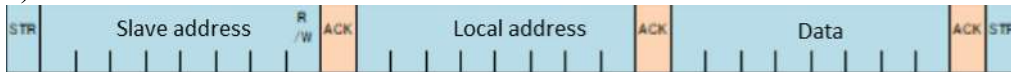

b) Read

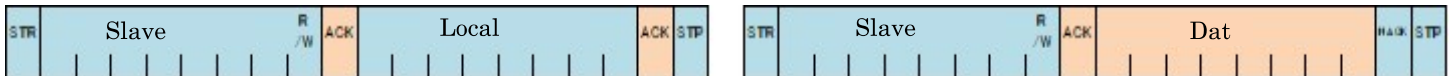

*SRT: start condition, STP: stop condition

* The Local address corresponds 「4. Command List」

* : Processing on the Master Side

(2) Communication Controls

1. Hard Constraints

Start Condition		SCLn "H" time \geq (SCnCLK cycle) x3
		SDAn setup time \geq (SCnCLK cycle) x2
		SDAn hold time \geq (SCnCLK cycle) x2
Stop Condition		SCLn "H" time \geq (SCnCLK cycle) x3
		SDAn setup time \geq (SCnCLK cycle) x2
		SDAn hold time \geq (SCnCLK cycle) x2

2. Command transmission constrains

- Communication frequency 95kHz~105kHz (corresponding clock stretch required).
- The camera can hold up to 10 commands at a time.
- In case the camera receives more than 10 commands, the local address becomes NACK (the slave address becomes ACK).
- One command per frame is processed.

- The commands received first are processed first
- The commands will not be processed and an NACK will be issued if more than the specified number of signals are sent during one transmission.

2.4 Pin Processing

2.4.1 Pin processing

The following indicate the terminal state after the camera activation:

Terminal Name	Contents	Polarity	Remarks
SCL	I2C Clock	High	Pulled up at the camera board (3.3V)
SDA	I2C Data	High	Pulled up at the camera board (3.3V)
ERROR	Camera Board Error Notification GPIO	High	Abnormal time low output

2.4.2 Unused pins processing

The following indicate the processing for unused pins

Terminal name	Contents	Polarity	Remarks
TEST	Unused	Not fixed	Open
UART16	Unused	High	Pulled up at the camera board (3.3V)
UART14	Unused	High	Pulled up at the camera board (3.3V)

3. Operation Sequence

3.1 State transition diagram

The following shows the state transition diagram. There are the following 6 states.

The transition to each state is done by the “SetModuleState” command.

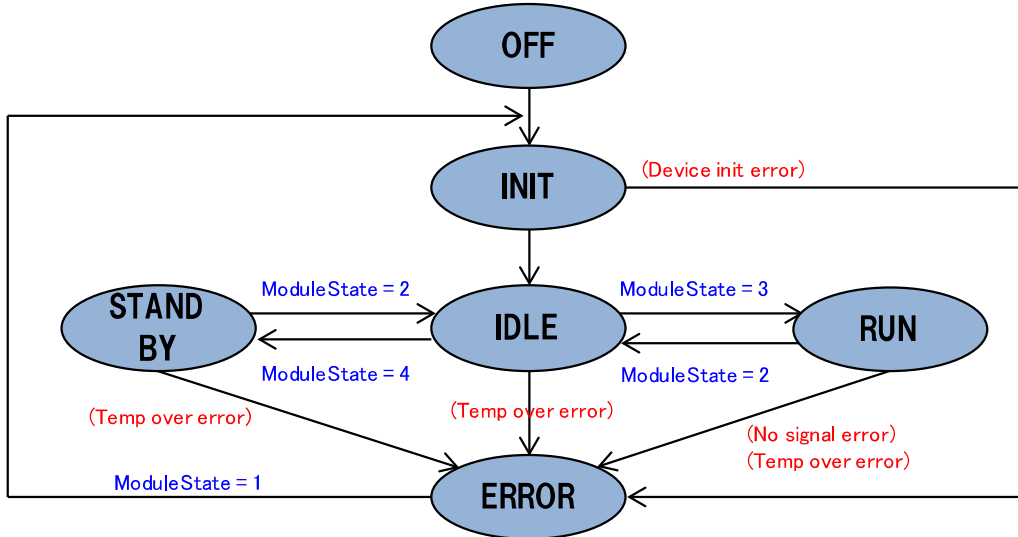

State	Contents	I2C Commands		Remarks
		Write	Read	
OFF	Power OFF	-	-	
INIT	Device initialization (including FPGA configuration)	-	-	
IDLE	Waiting	All commands	All commands	No LD light, no data output
RUN	Normal operation	All commands	All commands	No LD light, no data output
STANDBY	Standby	Only for ModuleState	All commands	No LD light, no data output
ERROR	Error occurred	Only for ModuleState	All commands	No LD light, no data output

3.2 Startup sequence

The following is an example of the startup sequence of the camera.

The camera board starts the initialization of each device after the TOF camera is powered ON. After the initialization is completed after this is completed the camera transitions automatically into IDLE.

If necessary, a state check will be performed.

While the camera is in IDLE, if RUN instructions are issued the TOF camera starts the normal operation.

* While the CPU is working the I2C becomes NACK

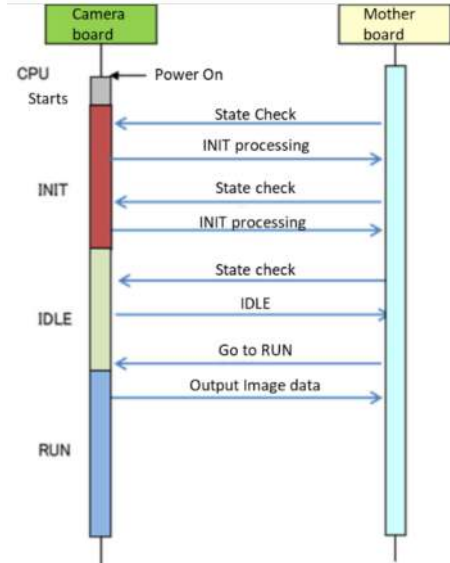

Item	Register name	LocalAddress	Setting value
Start Check	ModuleState	0x02	-
RUN Transfer instructions	ModuleState	0x02	0x03

3.3 Exit Sequence

An example of the end sequence operation is shown.

While the TOF camera is in operation, the IDLE instructions need to be issued.

After the camera transitioned into IDLE, one can turn OFF the power.

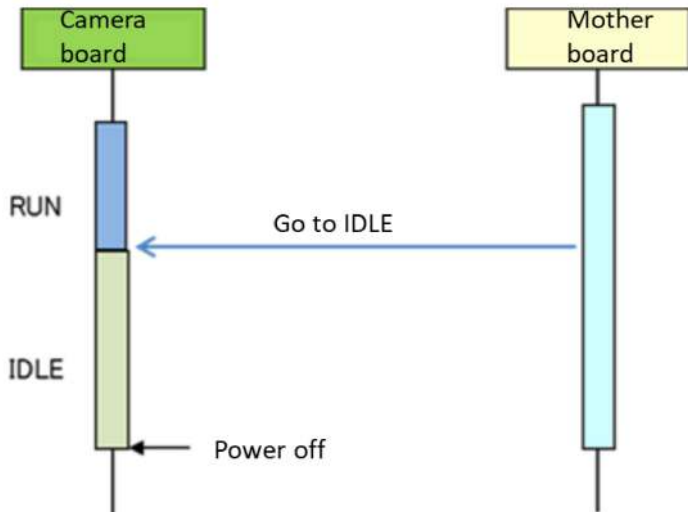

Item	Register name	LocalAddress	Setting Value
IDLE Transfer Instructions	ModuleState	0x02	0x02

3.4 Error processing

If a malfunction is detected within the camera, the camera transitions into ERROR mode, the ERROR (PinNo45) issues a Low signal.

On the motherboard ERROR output (ERROR Pin->Low), perform state restoration by I2C command.

For other kinds of undetected abnormalities, the camera is automatically initialized if the camera detects runaway through the watchdog timer.

Item	Register name	LocalAddress	Setting Value
INIT Transfer Instructions	ModuleState	0x02	0x01

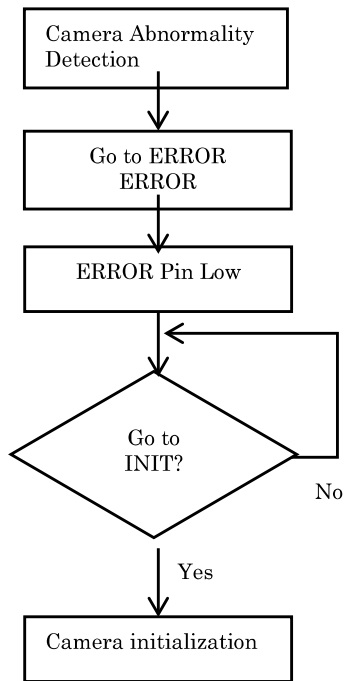

4. Commands list

Local Address	Register name	Initial Value (HEX)	R/W	Outline of Register
0	Soft ver	0x28	R	Read Camera Version (*1) [b7:0] 0 to 255
1	ModuleType	0x01	R	Read Module Type [b7:0] 0 to 255
2	ModuleState	0x00	R/W	Setting / reading state transition Please refer to 3.1 State Transition Diagram for details. [b7:0] 0:Reserved 1:INIT(RESET) 2:IDLE 3:RUN(Normal operating) 4:STANDBY 5:ERROR 6 to 255:Reserved
3	Param_Init	0xFF	W	Factory reset parameters (Note) The camera is reset, when the command is executed [b7:0] 0:Reserved 1:Initialize 2 to 255:Reserved
4	ModuleErrorState	0x00	R	Read error state of camera [b7:0] 0:No error 1:Device operating error 2:Image output error 3:Camera temperature error 4 to 255:Reserved
5	Depth Range_near_H	0x00	R/W	Set / read minimum distance [mm] (*2) Min. detection distance(16bit) = Depth Range_near_H << 8 + Depth Range_near_L [b15:0] 0 to 99 :Not used(Setting prohibited) 100 to 13230 :Setting value 13231 to 65535 :Reserved
6	Depth Range_near_L	0xC8	R/W	
7	Depth Range_far_H	0x0B	R/W	Set / read maximum distance [mm] (*2) Max. detection distance(16bit) = Depth Range_far_H << 8 + Depth Range_far_L [b15:0] 0 to 99 :Not used(Setting prohibited) 100 to 13330 :Setting value 13331 to 65535 :Reserved
8	Depth Range_far_L	0xB8	R/W	
9	OutputSel	0x01	R/W	Change Image output method [b7:0]0: Parallel 36bit 1: Parallel 14bit (USB3.0) 2: Not used(Setting prohibited) 3: Parallel 16bit 4 to 255: Not used(Setting prohibited)
A	FarLimit_H	0x00	R/W	Set / read threshold of far distance Replace the distance equal to or greater than the set value with 0xFFFF. [b15:0] 0 : Auto setting (Automatically set in conjunction with Depth Range_far_H,L) 1 to 9 : Not used 10 to 65535 : Manual setting
B	FarLimit_L	0x00	R/W	
C	Not used			
D	Not used			
E	Smoothing Filter	0x77	R/W	Set / read smoothing filter processing of depth image [b7:0] 0: Smoothing filter OFF 1 to 118: Not used(Setting prohibited) 119: Smoothing filter ON 120 to 255: Not used(Setting prohibited)
F	Out Of Depth Range	0x00	R/W	Set / read replacement method of out-of-range measurement data Image data of out-of-range data (error output) is replaced by appointed value. Threshold distance value of near is set by Depth Range_near_H,L(address: 0X05, 0X06), [b1:0] 0: to 0x0000 1: to 0xFFFF 2: to the value of Depth Range_near_H,L 3: Reserved [b2:7] Reserved
10	Not used			

TOF Camera (Indoors, RGB/IR)

11	Gradient_H	0x00	R/W	Set / read the gradient of Depth Correct slope of Depth linearity. Value big -> gradient big, Value small -> gradient small There are two types of operation auto setting and manual one. The value of the inclination 3331 is 1 time, and the inclination to be set is the following: Setting value = Depth inclination correction value(16bit)/3331
12	Gradient_L	0x00	R/W	Depth inclination correction value(16bit) = Gradient_H<<8 + Gradient_L [b15:0] 0 to 65535
13	Offset_H	0x00	R/W	Set / read Depth offset correction Set the correction value for the offset that is automatically set according to the value of Depth Range_near (address: 0x05, 0x06). The set value is a 2's complement, and the unit is [mm]. Offset value = Offset_H<<8 + Offset_L
14	Offset_L	0x00	R/W	[b15:0] 0x0000~0xFFFF (- 32768~ 32767)
15	LuminescenceStrength_H	0x07	R/W	Set / read of emission intensity Emission intensity(16bit) = LuminescenceStrength_H<<8 + LuminescenceStrength_L This register is valid when IR AE ([b0]) of AE Setting (address: 0x25) is OFF. When IR AE is ON, the set value is ignored. [b15:0] 0 : Auto setting (Optimum value is set in conjunction with Depth Range_near_H,L) 1 to 9: Reserved 10 to 8000 : Manual setting (Min:10, Max:8000) 8001 to 65535: Reserved
16	LuminescenceStrength_L	0xD0	R/W	
17	Depth Coordinate Trans	0x01	R/W	On / Off Depth Coordinate transformation (*3) [b7:0] 0: OFF 1: ON 2 to 255: Reserved
18	IR Selection	0x03	R/W	Set / read IR image type [b0] IR gamma correction setting [b1] Select the presence or absence of BG in the output value of the IR image [b0] 0: Not used 1: $\gamma = 1$ [b1] 0: with BG 1: without BG [b2:7] Reserved
19	Not used			
1A	RGB Exposure	0x50	R/W	Set / read RGB exposure time It is valid when RGB AE [b1] of AE Select (address: 0x25) is OFF [b7:0] 0 to 200(0:Minimum exposure, 200:Maximum exposure) 201 to 255 Reserved
1B	Not used			
1C	RGB R_Gain	0x24	R/W	Set / read R gain of RGB Minimum setting: 0.03125 times, Maximum setting: 7.96875times [b4:0] Decimal part [b7:5] Integer part
1D	RGB G_Gain	0x20	R/W	Set / read of G gain of RGB Minimum setting: 0.03125 times, Maximum setting: 7.96875times [b4:0] Decimal part [b7:5] Integer part
1E	RGB B_Gain	0x38	R/W	Set / read of B gain of RGB Minimum setting: 0.03125 times, Maximum setting: 7.96875times [b4:0] Decimal part [b7:5] Integer part
1F	Not used			
20	Not used			
21	Not used			
22	EDGE_DEL	0x60	R/W	Set/ read of edge removal A large setting value increases the effect of edge removal. [b7:0] 0 : OFF 1 to 254 : Setting value of edge removal 255 : Not used

TOF Camera (Indoors, RGB/IR)

23	CORING_H	0x00	R/W	Setting / reading small signal removal A large setting value increases the effect of small signal removal. Setting value(16bit) = CORING_H<<8 + CORING_L [b15:0] 0 : OFF 1 to 4095 : Setting value of small signal removal from 4096: Not used
24	CORING_L	0x30	R/W	
25	AE Select	0x03	R/W	Setting / reading of Auto Exposure (*4) [b0] IR Auto Exposure 0: OFF, Operates with the value set by LuminescenceStrength_H,L (address: 0x15, 0x16) 1: ON, AE operates so as to be the IR value set by IRAE_TargetVal (address 0x2A, 0x2B) [b1] RGB Auto Exposure 0: OFF, Operates with the value set by RGB Exposure (address: 0x1A) 1: ON, AE operates so as to be the RGB value set by RGBAE_TargetVal (address 0x39, 0x3A) [b7:2] Reserved
26	IRAE_StrX	0x00	R/W	Start position X of the IR-AE effective area (20 × 15 block) (*5) [b7:0] 0 to 19 : Start position X from 20 : Not used
27	IRAE_StrY	0x00	R/W	Start position Y of the IR-AE effective area (20 × 15 block) (*5) [b7:0] 0 to 14 : Start position Y from 15 : Not used
28	IRAE_SizeX	0x14	R/W	Width of IR-AE effective area (20 × 15 blocks) in X direction. (IRAE_StrX + IRAE_SizeX) is the effective width in the X direction. (*5) [b7:0] 0 : NotUsed 1 to 20 : X effective width from 21 : Not used
29	IRAE_SizeY	0x0F	R/W	Width of IR-AE effective area (20 × 15 blocks) in Y direction. (IRAE_StrY + IRAE_SizeY) is the effective width in the Y direction. (*5) [b7:0] 0 : NotUsed 1 to 15 : Y effective width from 16 : Not used
2A	IRAE_TargetVal_H	0x0A	R/W	Target 12-bit IR value for IR-AE (*5) Target IR value(12bit) = IRAE_TargetVal_H<<8 + IRAE_TargetVal_L [b15:0] 0 to 3800 : Setting value from 3801 : Not used
2B	IRAE_TargetVal_L	0xF0	R/W	
2C	Not used			
2D	Not used			
2E	Not used			
2F	Not used			
30	Not used			
31	Not used			
32	Not used			
33	Not used			
34	Not used			
35	RGBAE_StrX	0x05	R/W	Start position X of the RGB-AE effective area (20 × 15 block) (*6) [b7:0] 0 to 19 : Start position X from 20 : Not used
36	RGBAE_StrY	0x04	R/W	Start position Y of the RGB-AE effective area (20 × 15 block) (*6) [b7:0] 0 to 14 : Start position Y from 15 : Not used
37	RGBAE_SizeX	0x0A	R/W	Width of RGB-AE effective area (20 × 15 blocks) in X direction. (RGBAE_StrX + RGBAE_SizeX) is the effective width in the X direction. (*6) [b7:0] 0 : Not used 1 to 20 : X effective width from 21 : Not used
38	RGBAE_SizeY	0x07	R/W	Width of RGB-AE effective area (20 × 15 blocks) in Y direction. (RGBAE_StrY + RGBAE_SizeY) is the effective width in the Y direction. (*6) [b7:0] 0 : Not used 1 to 15 : Y effective width from 16 : Not used

TOF Camera (Indoors, RGB/IR)

39	RGBAE_TargetVal_H	0x0E	R/W	Target 12-bit RGB value for RGB-AE (*6) Target RGB value(12bit) = RGBAE_TargetVal_H<<8 + RGBAE_TargetVal_L [b15:0] 0 to 3800 : Setting value from 3801 : Not used
3A	RGBAE_TargetVal_L	0xD8	R/W	
3B	RGBAE_Frequency	0x00	R/W	Frequency setting for anti-flicker of RGB-AE (*6) [b7:0] 0 : 50Hz 1 : 60Hz from 2 : Not used
3C	Not used			
3D	Not used			
3E	Not used			
3F	Not used			
40	LuminescenceStrengthMax	0x15	R/W	Setting / reading maximum emission strength Maximum emission strength(16bit) = LuminescenceStrengthMax_H<<8 + LuminescenceStrengthMax_L This register sets the maximum emission strength of IR-AE. [b15:0] 0 to 9 :Not used 10 to 8000 : Setting value 8001 to 65535 : Reserved
41	LuminescenceStrengthMax	0xE0	R/W	
42	Not used			
43	Not used			
44	Not used			
45	Not used			
46	Not used			
47	Not used			
48	Not used			
49	ModuleTemp_H	0x00	R	Reading Module temperature [°C] The value is a 2's complement, and it is output with a value obtained by multiplying the actual temperature by 10 times. To return to the actual temperature, multiply by 0.1. Module temperature = (ModuleTemp_H<<8 + ModuleTemp_L) * 0.1 [b15:0] 0 to 65535 : Module temperature * 10
4A	ModuleTemp_L	0x00	R	
ED	ParamSaveSel	0x01	R/W	Parameter save settings for each communication [b7:0] 0: OFF : without save settings 1: ON : with save settings from 2 : Not used

Note1 : Set the register in the following order: high order (H) then low order (L).

Note2 : Operation is not guaranteed if you enter anything other than the setting value specified in this register map.

Note3 : If one inputs commands for NotUsed, Reserved, operation is not guaranteed.

(*1) Please contact the sales person for Soft ver of your camera.

(*2) Please set the distance range to be used.
The optimum setting is done inside the camera according to the set distance range.

Please note that distance shorter than the minimum distance setting can not be used.
Please make a distance difference of 100 mm or more by setting the maximum distance and minimum distance.

(*3) The distance value around the screen becomes farther from the center distance value.
For example, when imaging a plane, it curves as shown below.
Depth Coordinate Trans is a process to correct the distance difference between the center and the around.

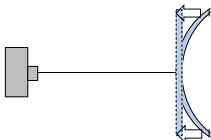

(*4) When changing the register related to IR-AE, the setting operation is performed according to the following flow.

Flow of setting emission strength

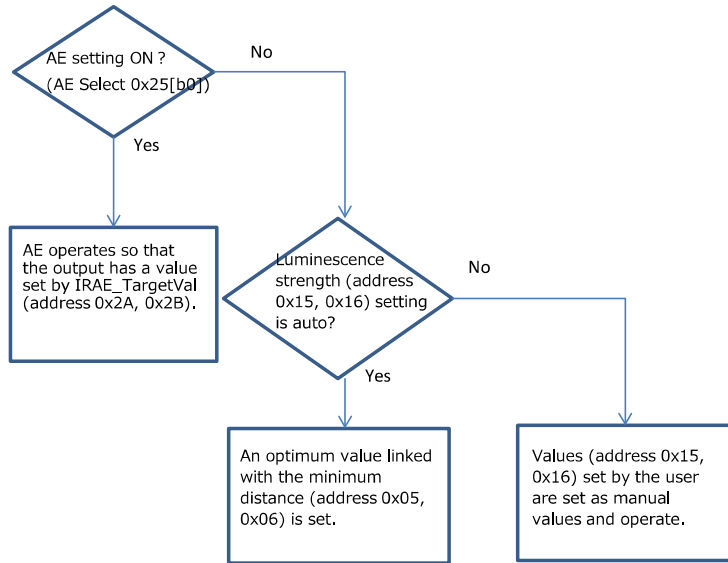

(*5) About setting value of IR-AE

The effective area of the AE is divided into 20 x 15 (1 block 16 x 16) and the output image is divided into 20 x 15 (1 block 16 x 16), and within the effective area determined by the start position (IRAE_StrX: 0x26, IRAE_StrY: 0x27) and the block size (IRAE_SizeX: 0x28, IRAE_SizeY: 0x29) Blocks are used.

An average frame value is calculated for each block of the effective area, and the maximum value among the average values is used as the IR acquisition value.

In the AE, the emission strength is automatically adjusted

so that the acquired value of IR becomes the target IR value (IRAE_TargetVal: 0x2A,0x2B) of IR-AE.

*Calculation of IR is internally calculated with 12 bits. Therefore, IRAE_TargetVal: 0x2A, 0x2B should be set with 12 bits.

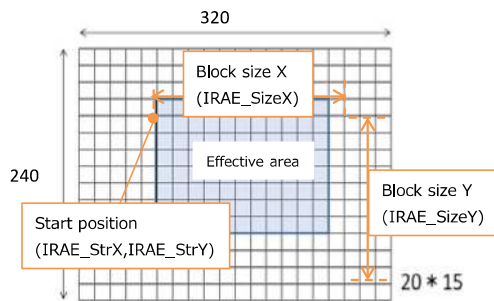

(*6) About setting value of RGB-AE

The effective area of the AE is divided into 20 x 15 (1 block 32 x 32) and the output image is divided into 20 x 15 (1 block 32 x 32), and within the effective area determined by the start position (RGBAE_StrX: 0x35, RGBAE_StrY: 0x36) and the block size (RGBAE_SizeX: 0x37, RGBAE_SizeY: 0x38) Blocks are used.

An average frame value is calculated for each block of the effective area, and the maximum value among the average values is used as the RGB acquisition value.

In the AE, the emission strength is automatically adjusted

so that the acquired value of RGB becomes the target RGB value (RGBAE_TargetVal: 0x39,0x3A) of RGB-AE.

* To set the fixed exposure time, perform flicker countermeasure frequency setting (RGBAE_Frequency: 0x3B) according to the environment to

However, in the case of an environment that can not be fully adjusted by digital gain, processing is performed with shorter exposure time.

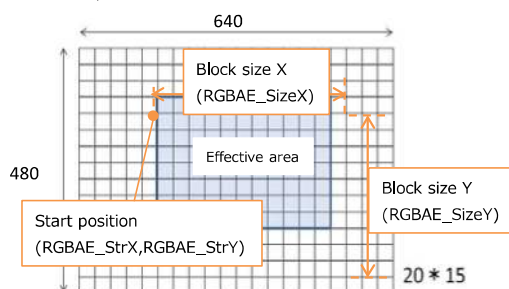

5. Others

5.1 Lot number

- The lot number is assigned in the following way

YYYYMMDD * * * * * 01

(* * * * * Panasonic management number)

- Display position

There will be a seal with the lot number attached at the bottom of the camera.

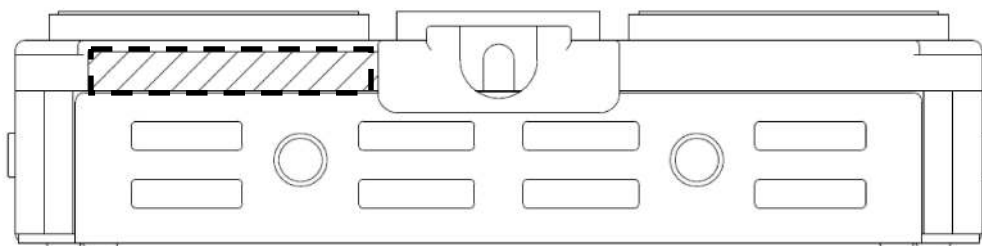

6. Important Notes

6.1 Safety precautions

- This product is meant for indoors. Please do not use outdoors or in wet places.
- Please do not exceed the rated voltage range and environmental conditions
- If the camera is used beyond the specification range, there is the danger of fire due to abnormal heat generation, smoke etc.
- If dust, metal, water, etc. enter the product, it may cause failure, electric shock, fire; consider carefully the installation and usage.
- Please use the specified power supply and connect correctly. Failure to do so will result in fire, electric shock, etc. due to product failure, abnormal heat generation, smoke etc.
- Depending on the conditions of use of this product, the temperature of the outer shell surface will be high, so please use carefully and do not touch it or make sure it has an enclosure safe for touching.
- Do not disassemble or modify this product. There is the danger of laser exposure and other hazards.

6.2 Usage Precautions

6.2.1 Basic Principles

The sensor for distance image shooting is a sensor that measures the distance by reflection of near infrared rays. Please confirm the performance and reliability. Caution is generally necessary in the following cases:

① **Strong reflection of the object**

When receiving reflected light from a regularly reflecting object such as a mirror, the received light power becomes extremely strong, saturation of pixels happens and the measurement cannot be performed correctly.

In addition, errors may occur in distance measurement even at positions other than the object being measured.

② **Strong ambient light**

An error in distance measurement may occur when light with a near infrared wavelength component, e.g. sunlight, incandescent lamp, halogen light, heater, etc., is irradiated within the measurement area. Furthermore, if the ambient light becomes strong, pixel saturation may occur, and normal measurement may not be possible.

③ **Fast movement of the measured object**

Miscalculation of the outline of the object can occur resulting in errors in the distance measurement.

④ **Vicinity of floors, walls to the measured object**

Multiple reflections e.g. light reflected by a wall, floor, etc. being reflected again by the object to be measured) may result in errors in measurement.

⑤ **Other points to be aware of:**

- There may be errors in the distance measurement depending on the distance and reflectance of the object to be measured and the position in the screen.
- Errors may occur in distance measurement immediately after starting up the product or when the

emission intensity suddenly changes

⑥ **Continuous operation**

We recommend operation with intensity below the recommended value.

However, this does not necessarily apply if it meets the camera internal temperature limit shown in 2.1.4.

In addition, this product uses a semiconductor laser, the emission intensity may decrease with long-term use.

Please set the emission intensity considering aged deterioration.

6.2.2 Usage precautions

- Do not directly touch the lens surface and protective panel surface with bare hands or pressurize it. Dirt may affect the optical characteristics, distance characteristics, etc.
- If the TOF camera is dropped, it will cause breakage of the outer part, cracks in the circuit part, disconnection, etc. Therefore, please be careful
- Do not remove screws attached to this product. If the screw loosens, the functions of the product may be affected.
- Do not apply excessive load to the power jack or connector in each direction.

6.2.3 Static Charge Precautions

- Due to static electricity or surge voltage, this product may cause damage to circuit parts and lower reliability. Please handle static electricity thoroughly with reference to the following example when handling.
 - Eliminate electric charge caused by wrist strap, conductive clothing, conductive shoes, conductive floor material, etc.
 - Eliminate electric charge caused by grounding devices, jigs, etc. in the work area
 - Ground the working table, storage shelf, etc. with conductive material
- Please install properly the equipment, jigs and work area. Also, regarding equipment connections, it is recommended to implement surge countermeasures.
- When insulators such as glass and plastics are used for the equipment and jigs, please take ensure the following:
 - Conductivity via conductive material
 - Anti-static via humidification
 - Neutralization of electric charge via static control unit (ionizer)

6.2.4 Cleaning

- Protective use a soft paper towel or wiper to wipe off the dirt when the lens or protective panel are dirt
- Please do not use chemicals because they may cause resin cracks, discoloration and deterioration.

6.2.5 Storage

- Please use the TOF camera within one year from the date of delivery and keep it in a stable temperature and humidity environment in order to maintain the same properties as at delivery
- Please manage carefully the storage environment since in an atmosphere containing corrosive gas or the like, there is a risk of deterioration of properties and change of the surface of the product.

6.3 Laser Safety

- This product is based on the risk group specified in "IEC 60825 - 1, JIS - C - 6802" (safety standards of laser products). It corresponds to class 1.
- Since the laser explanation label is not displayed on this product, follow the instructions "IEC 60825-1, JIS-C-6802" for the embedded equipment exterior, and display them.
- Please be careful as the product might be damaged and there is a danger of hurting one's eyes with the laser light, when the product is handled or adjusted by methods not described in this specification sheet.

6.4 EMI

- The noise level is equivalent to the following classes. Please note the noise level was measured in our test environment, this meaning we did not obtain the certification of the following standards
 - Equivalent to VCCI Class
 - Equivalent to CISPR 22 class B
- A ferrite core used for confirmation, the ferrite core was wrapped around the AC adapter cable as follows.
 - Part number: HF70T31X13X19 made by TDK
 - Number of turns: 2 turns or more

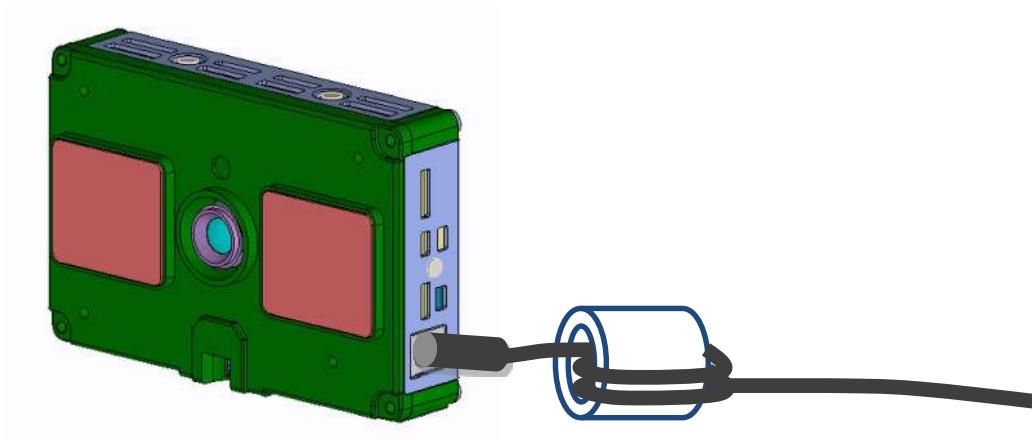

6.5 Special Items

- Please do not use or dispose (transfer, loan, diversion, license etc.) directly or indirectly for the purpose of military use in accordance to the Foreign Exchange and Foreign Trade Control Law and related ministry ordinance, etc. and export control by resolution of the United Nations Security Council. Please comply with the various regulations related to this document regarding all tangible items (deliverables, equipment, fixtures, parts, etc.) and intangible (all technologies, know-how, information, intellectual property rights, etc.)
- The contents described in this document are indicative of the characteristics of the product and do not guarantee or license the right to intellectual property rights or other rights of our company and third parties.
- Please contact us beforehand, in case of malfunction or miss-operation that could result to harm to the human body or life or threaten human life.
- Please take care that the acquired images (including recording) does not violate privacy.
- If you find any trouble etc. in this product, please contact the sales person.
- The quality assurance of this product shall be one year after delivery and shall be limited to the items and their ranges described in this specification sheet. After delivery, if a defect due to our company's responsibility should be identified, we will repair this product or provide alternative products. However, even within the warranty period, we are not liable for damages arising from natural disasters and inappropriate use.
- Please do not reverse engineer the product through disassembly or analysis without obtaining permission from our company
- Please understand beforehand that specifications and appearance of this product may be changed without prior notice for improvement.