

LOC		DIST		REVISIONS			
P	LTR	DESCRIPTION	DATE	DN	APVD		
P		REVISED PER ECO-15-016251	13NOV15	KG	CD		

- THIS PLUG WILL MATE WITH ANY 17C5, SIZE 4 RECEPTACLE IN AMPLIMITE SERIES.
- MAXIMUM WIRE INSULATION TO BE USED WITH THIS PLUG IS  $\phi$ .068.
- THIS CONNECTOR ACCEPTS (5) POWER 8, OR COAX PIN CONTACTS IN POSITIONS A1 THRU A5, PURCHASED SEPARATELY.
- THIS CONNECTOR ACCEPTS SIZE 20 PIN SIGNAL CONTACTS IN POSITIONS 1 THRU 12, PURCHASED SEPARATELY.
- UL/CSA DESIGNATION STAMPED IN THIS AREA, OPTIONAL.
- STEEL PER ASTM-A-109.
- BRASS PER MIL-C-50 AND ASTM-B-36 UNS NO. C26000.
- CADMIUM PLATED PER QQ-P-416.
- FINISH: GOLD PLATED PER MIL-G-45204 TYPE II, GRADE C, CLASS 1 OVER COPPER PER MIL-C-14550, CLASS IV.
- WESTINGHOUSE PART NO. 97942-645A935H07, INK STAMPED, FAR SIDE.
- FINISH: TIN PER ASTM-B-545, .000400 MIN THK OVER COPPER PER AMS2418 .000050 MIN THK.
- GROUNDING INDENTS FOR 212514-5 & 5-212514-5 ONLY.
- FINISH: ZINC PLATE PER ASTM-B-633 .000200-.000400 THK WITH SUPPLEMENTARY CHROMATE (Cr3+).

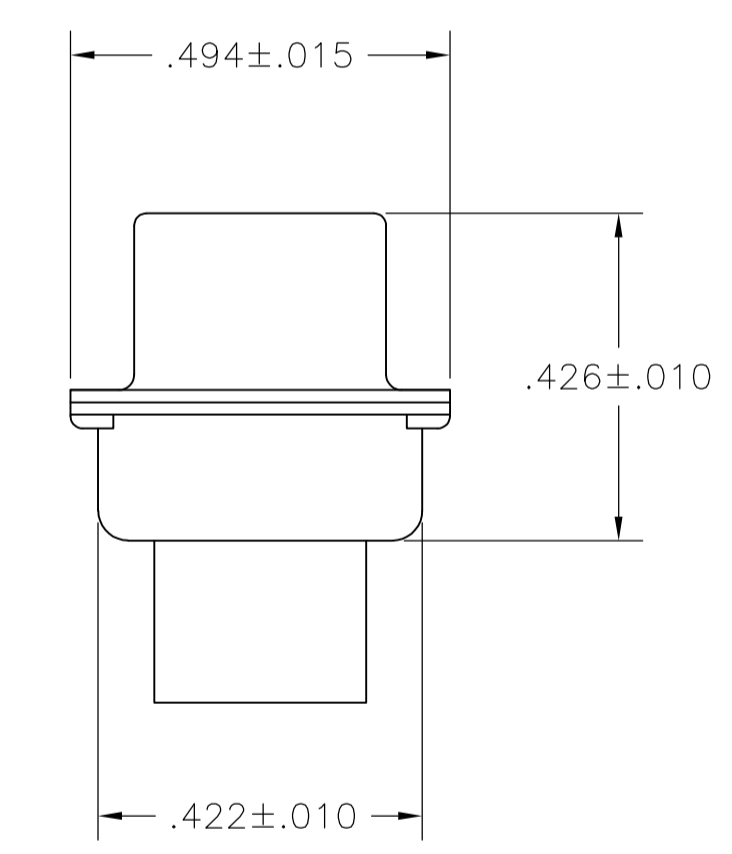
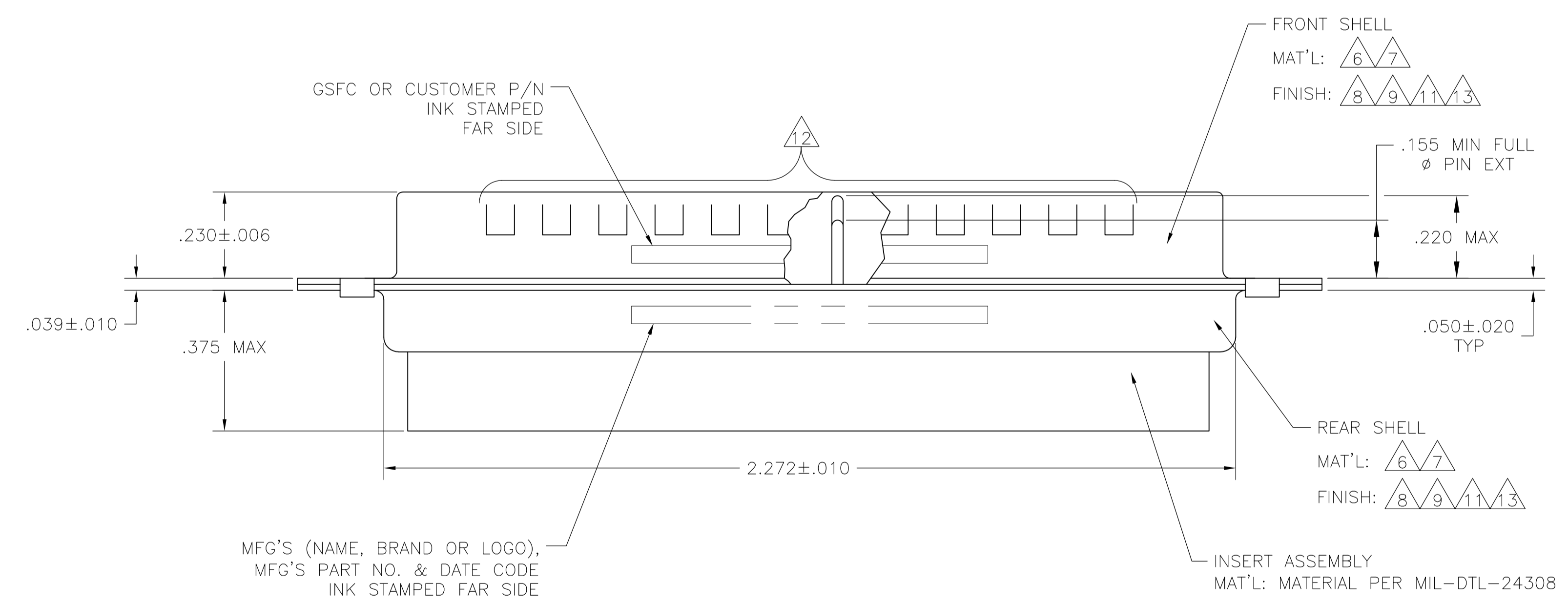
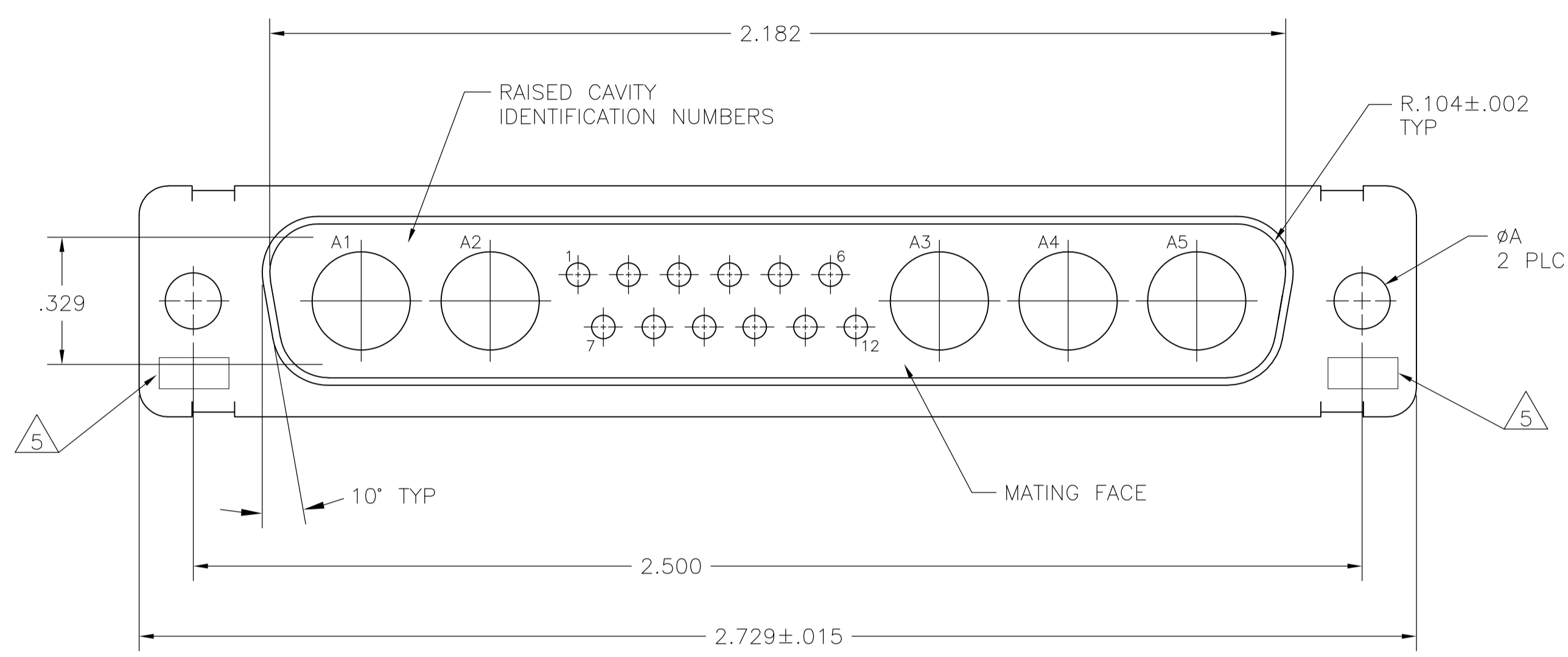

6 12 11	.120	-	5-212514-5
6 13	.120	-	5-212514-1
6 11 12	.120	-	212514-5
7 9	.154	311P405-17S-B-15	212514-4
7 9	.120	311P405-17S-B-12	212514-3
6 8 10	.120	-	212514-2
6 8	.120	-	212514-1
REMARKS	ØA	GSFC P/N	PART NO.

THIS DRAWING IS A CONTROLLED DOCUMENT.

DIMENSIONS: INCHES	TOLERANCES UNLESS OTHERWISE SPECIFIED:	APPROVED: MANJUNATH G.M. 27-May-15	NAME: PLUG ASSEMBLY
0 PLC ± -	1 PLC ± -	CHK: CHARLES THOMAS 27-May-15	AMPLIMITE 17C5
2 PLC ± -	3 PLC ± .005(0.13)	APPROVED: CHARLES THOMAS 27-May-15	SIZE 4, SERIES 109, COAX MIX
4 PLC ± -	ANGLES ± # 0', 30'	APPLICATION SPEC	SIZE: A1
MATERIAL	FINISH	WEIGHT	SCALE: 4:1
			SHEET 1 OF 1
CUSTOMER DRAWING		SCALE: 4:1	REV P

STE TE Connectivity