

Sealed Choke Coil SDES064T type

■ Features

Low profile : 6.0mm x 6.0mm x 4.0mm

Low coil resistance with large currents.

High magnetic shield construction should actualize high resolution for EMC protection.

100% lead (Pb) free meet RoHS standard

■ Application

Cellular PSones, LCD displays, HDDs, DVCs, DSCs, PDAs etc..

■ Outline Dimensions

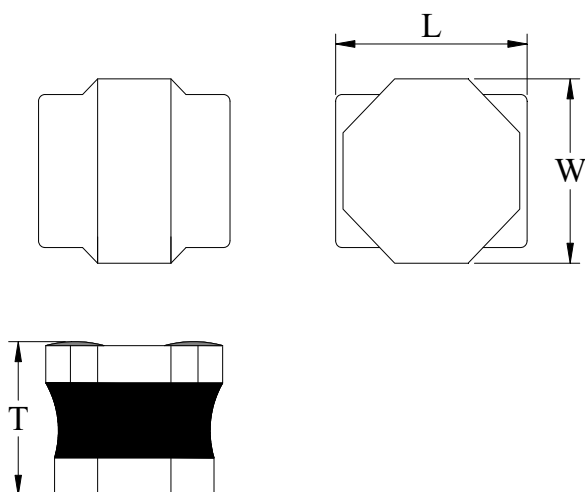

Code	Dimensions (mm)
L	6.0 ± 0.2
W	6.0 ± 0.2
T	4.0 Max.

Note: This graph is in regard to outline dimensions spec. For outer appearance, please refer to actual product.

■ Marking

The inductor is marked with a 3-digit code

Example -- 15.0 μ H → 150

Upside of Chip

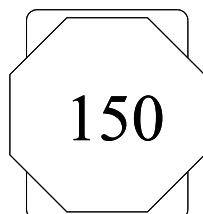

■ Recommend Land Pattern Dimensions

The customer shall determine the land dimensions shown below after confirming and safety.

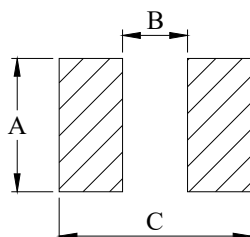

A	4.5
B	2.2
C	6.5

Unit : mm

Specifications

Part Number	L0 Inductance (μ H) @ (0A)	R _{dc} (m Ω)		Heat Rating Current DC Amps. I _{dc} (A)		Saturation Current DC Amps. I _{sat} (A)	
		Typical	Maximum	Typical	Maximum	Typical	Maximum
SDES064T-1R5MS	1.5	10.0	13.0	6.60	5.90	7.80	7.00
SDES064T-2R2MS	2.2	14.0	17.0	6.30	5.70	7.30	6.40
SDES064T-3R3MS	3.3	19.0	24.0	5.10	4.60	5.50	5.00
SDES064T-4R7MS	4.7	22.0	26.0	4.75	4.25	5.00	4.50
SDES064T-6R8MS	6.8	31.0	39.0	4.20	3.60	4.10	3.70
SDES064T-8R2MS	8.2	38.0	47.0	3.40	3.12	3.50	3.15
SDES064T-100MS	10.0	39.0	49.0	3.40	3.10	3.40	3.10
SDES064T-150MS	15.0	69.0	87.0	2.50	2.30	2.60	2.34
SDES064T-220MS	22.0	95.0	120.0	2.20	2.00	2.20	2.00
SDES064T-330MS	33.0	136.0	171.0	2.00	1.80	1.70	1.50
SDES064T-470MS	47.0	193.0	232.0	1.60	1.45	1.40	1.20
SDES064T-560MS	56.0	245.0	306.0	1.40	1.20	1.30	1.15
SDES064T-680MS	68.0	285.0	360.0	1.20	1.10	1.20	1.10
SDES064T-101MS	100.0	420.0	530.0	1.05	0.95	1.00	0.95
SDES064T-121MS	120.0	480.0	540.0	0.90	0.81	0.92	0.82
SDES064T-221MS	220.0	830.0	1,040	0.64	0.58	0.71	0.64
SDES064T-331MS	330.0	1265.0	1575.0	0.58	0.52	0.58	0.52

* : If you require another part number please contact with us.

** : Inductance Tolerance \pm 20%

Note 1. : All test data is referenced to 25°C ambient.

Note 2. : Test Condition:100KHz, 1.0Vrms

Note 3. : I_{dc} : DC current (A) that will cause an approximate Δ T of 40°C

Note 4. : I_{sat} : DC current (A) that will cause L0 to drop approximately 30%

Note 5. : Operating Temperature Range -55°C to +125°C

Note 6. : The part temperature (ambient + temp rise) should not exceed 125°C under the worst case operating conditions. Circuit design, component placement, PCB trace size and thickness, airflow and other cooling provision all affect the part temperature. Part temperature should be verified in the end application.

Note 7. : The rated current as listed is either the saturation current or the heating current depending on which value is lower.

Current Characteristic

