



Loadmonitors - GAMMA series
 Multifunction
 Fault latch
 Recognition of disconnected consumers
 Suitable for VFI (10 to 100Hz)
 Supply voltage selectable via power modules
 2 change-over contacts
 Width 22.5mm
 Industrial design



Technical data

1. Functions

Load monitoring ($\cos\varphi$) in 1- or 3-phase mains with adjustable thresholds, timing for start-up suppression and tripping delay separately adjustable and the following functions which are selected by means of rotary switch:

OVER	Overload monitoring
OVER+LATCH	Overload monitoring with fault latch
UNDER	Underload monitoring
UNDER+LATCH	Underload monitoring with fault latch
WIN	Monitoring the window between Min and Max
WIN+LATCH	Monitoring the window between Min and Max with fault latch

2. Time ranges

	Adjustment range
Start-up suppression time:	1s 100s
Tripping delay:	0.1s 40s

3. Indicators

Green LED ON:	indication of supply voltage
Green LED flashes:	indication of start-up suppression time
Yellow LED R ON/OFF:	indication of relay output
Yellow LED I=0 ON/OFF:	indication of disconnected consumers
Red LED ON/OFF:	indication of failure of the corresponding threshold
Red LED flashes:	indication of tripping delay of the corresponding threshold

4. Mechanical design

Self-extinguishing plastic housing, IP rating IP40
 Mounted on DIN-Rail TS 35 according to EN 60715
 Mounting position: any
 Shockproof terminal connection according to VBG 4 (PZ1 required), IP rating IP20
 Tightening torque: max. 1Nm
 Terminal capacity:
 1 x 0.5 to 2.5mm² with/without multicore cable end
 1 x 4mm² without multicore cable end
 2 x 0.5 to 1.5mm² with/without multicore cable end
 2 x 2.5mm² flexible without multicore cable end

5. Input circuit

Supply voltage:
 12 to 400V a.c. terminals A1-A2 (galvanically separated) selectable via power modules TR2

Tolerance: according to specification of power module
 Rated frequency: according to specification of power module
 Rated consumption: 2VA (1.5W)
 Duration of operation: 100%
 Reset time: 500ms
 Residual ripple for d.c.: -
 Drop-out voltage: >30% of the supply voltage
 Overvoltage category: III (in accordance with IEC 60664-1)
 Rated surge voltage: 4kV

6. Output circuit

2 potential free change-over contacts
 Rated voltage: 250V a.c.
 Switching capacity: 750VA (3A / 250V a.c.)
 If the distance between the devices is less than 5mm.
 Switching capacity: 1250VA (5A / 250V a.c.)
 If the distance between the devices is greater than 5mm.
 Fusing: 5A fast acting
 Mechanical life: 20 x 10⁶ operations
 Electrical life: 2 x 10⁵ operations
 at 1000VA resistive load
 max. 60/min at 100VA resistive load
 max. 6/min at 1000VA resistive load
 (in accordance with IEC 60947-5-1)
 III (in accordance with IEC 60664-1)
 4kV

7. Measuring circuit

Measured variable: a.c. Sinus (10 to 400Hz)
 Measuring input voltage:
 1-phase mains 40 to 415V a.c. (300V against ground) terminals L1-L2/L3
 3-phase mains 3~ 40/23V to 415/240V, terminals L1-L2-L3
 Overload capacity:
 1-phase mains 500V
 3-phase mains 3~ 500/289V
 Input resistance: ≥1MΩ
 Measuring input current: 0.5 to 10A, terminals L1-L1k (I>8A distance >5mm)
 Overload capacity: 11A permanently
 Input resistance: 5mΩ
 Switching threshold $\cos\varphi$
 Max: 0.2 to 1.0
 Min: 0.1 to 0.99
 Overvoltage category: III (in accordance with IEC 60664-1)
 Rated surge voltage: 4kV

9. Accuracy

Base accuracy: ±5° (equivalent to 5% at $\cos\varphi = 0.8$)
 Frequency response: -
 Adjustment accuracy: ≤5% (at $\cos\varphi = 0.8$)
 Repetition accuracy: ±1.8° (equivalent to 1.8% at $\cos\varphi = 0.8$)
 Voltage influence: -
 Temperature influence: ≤0.1% / °C

9. Ambient conditions

Ambient temperature: -25 to +55°C (in accordance with IEC 60068-1)
 -25 to +40°C (in accordance with UL 508)
 Storage temperature: -25 to +70°C
 Transport temperature: -25 to +70°C
 Relative humidity: 15% to 85%
 (in accordance with IEC 60721-3-3 class 3K3)
 Pollution degree: 3 (in accordance with IEC 60664-1)
 Vibration resistance: 10 bis 55Hz 0.35mm
 (in accordance with IEC 60068-2-6)
 Shock resistance: 15g 11ms
 (in accordance with IEC 60068-2-27)

Functions

When the supply voltage U is applied, the output relays switch into on-position (yellow LED R and LED I=0 illuminated) and the set interval of the start-up suppression (START) begins (green LED U flashes). Changes of the measured power factor ($\cos\phi$) during this period do not affect the state of the output relay. After the interval has expired the green LED is illuminated steadily. For all the functions the LEDs MIN and MAX are flashing alternating, when the minimum value for the measured power factor was chosen to be greater than the maximum value.

Overload monitoring (OVER, OVER+LATCH)

When the measured power factor exceeds the value adjusted at the MAX-regulator, the set interval of the tripping delay (DELAY) begins (red LED MAX flashes). After the interval has expired (red LED MAX illuminated), the output relays switch into off-position (yellow LED R not illuminated). The output relays again switch into on-position (yellow LED R illuminated), when the measured power factor falls below the value adjusted at the MIN-regulator (red LED MAX not illuminated). If the fault latch is activated (OVER+LATCH) and the measured power factor remains above the MAX-value longer than the set interval of the tripping delay, the output relays remain in the off-position even if the measured power factor falls below the value adjusted at the MIN-regulator. After resetting the failure (interrupting and re-applying the supply voltage), the output relays switch into on-position and a new measuring cycle begins with the set interval of the start-up suppression (START).

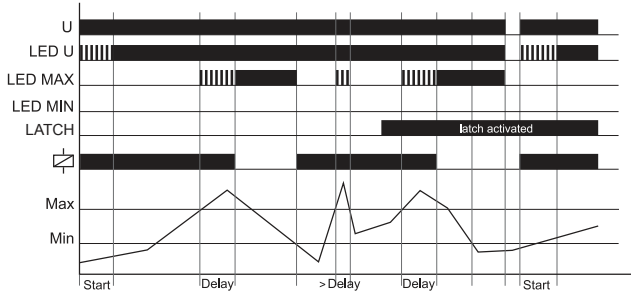

Underload monitoring (UNDER, UNDER+LATCH)

When the measured power factor falls below the value adjusted at the MIN-regulator, the set interval of the tripping delay (DELAY) begins (red LED MIN flashes). After the interval has expired (red LED MIN illuminated), the output relays switch into off-position (yellow LED R not illuminated). The output relays again switch into on-position (yellow LED R illuminated), when the measured power factor exceeds the value adjusted at the MAX-regulator. If the fault latch is activated (UNDER+LATCH) and the measured power factor remains below the MIN-value longer than the set interval of the tripping delay, the output relays remain in the off-position even if the measured power factor exceeds the value adjusted at the MAX-regulator. After resetting the failure (interrupting and re-applying the supply voltage), the output relays switch into on-position and a new measuring cycle begins with the set interval of the start-up suppression (START).

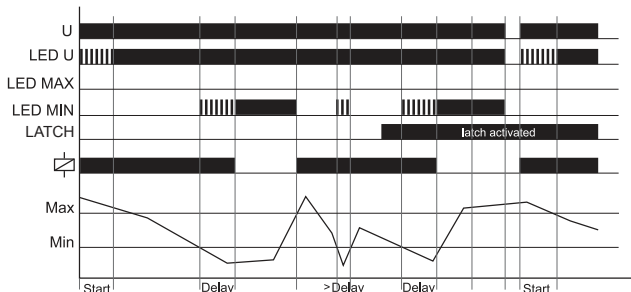

Window function (WIN, WIN+LATCH)

The output relays switch into on-position (yellow LED R illuminated) when the measured power factor exceeds the value adjusted at the MIN-regulator. When the measured power factor exceeds the value adjusted at the MAX-regulator, the set interval of the tripping delay (DELAY) begins (red LED MAX flashes). After the interval has expired (red LED MAX illuminated), the output relays switch into off-position (yellow LED R not illuminated). The output relays again switch into on-position (yellow LED R illuminated) when the measured power factor falls below the value adjusted at the MAX-regulator (red LED MAX not illuminated). When the measured power factor falls below the value adjusted at the MIN-regulator, the set interval of the tripping delay (DELAY) begins again (red LED MIN flashes). After the interval has expired (red LED MIN illuminated), the output relays switch into off-position (yellow LED R not illuminated).

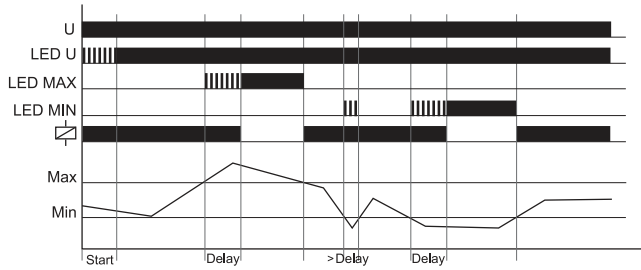

If the fault latch is activated (WIN+LATCH) and the measured power factor remains below the MIN-value longer than the set interval of the tripping delay, the output relays remain in the off-position even if the measured power factor exceeds the value adjusted at the MIN-regulator. If the measured power factor remains above the MAX-value longer than the set interval of the tripping delay, the output relays remain in the off-position even if the measured power factor falls below the value adjusted at the MAX-regulator. After resetting the failure (interrupting and re-applying the supply voltage), the output relays switch into on-position and a new measuring cycle begins with the set interval of the start-up suppression (START).

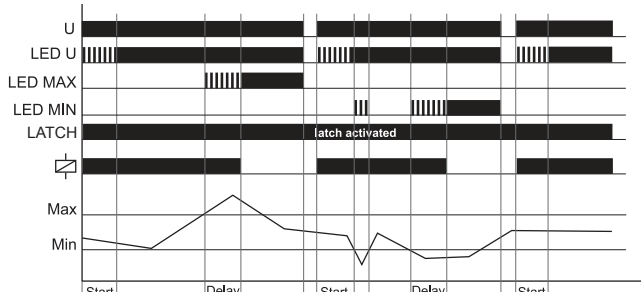

Recognition of disconnected consumers

When the current flow between L1i and L1k is interrupted (yellow LED I=0 illuminated) and no fault has been stored the output relays switch into on-position resp. remain in on-position (yellow LED R illuminated). When the current flow is restored, the measuring cycle is restarted with the set interval of the start-up suppression (START).

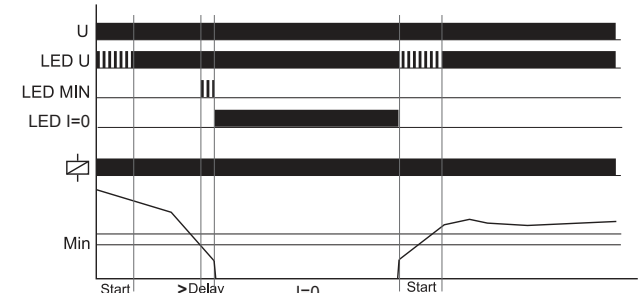

Connections

Connected to 3~ 400V mains with power module 24V a.c. without fault latch
 $I_N < 10A$

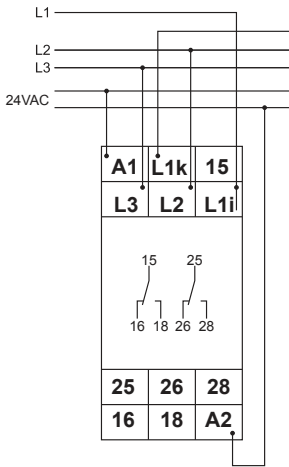

Connections

Connected to 3~ 400V mains with power module 400V a.c. and fault latch
 $I_N > 10A$

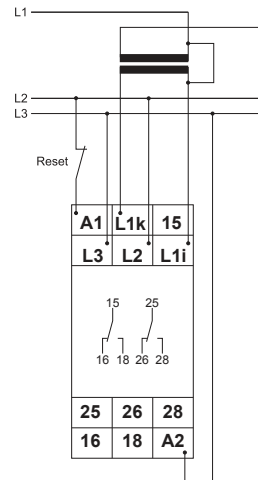

Connected to 1~ 230V mains with power module 230V a.c. without fault latch
 $I_N < 10A$

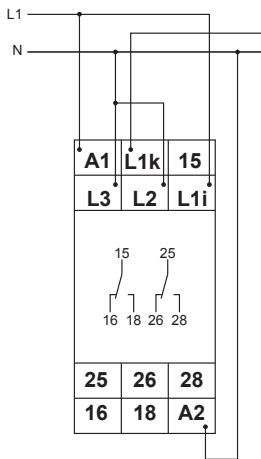

Dimensions

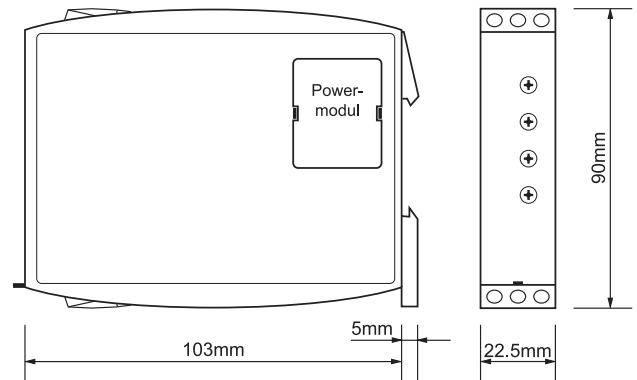

Connected to 3~ 400V mains with power module 400V a.c. and fault latch
 $I_N < 10A$

