

4

3

2

1

THIS DRAWING IS UNPUBLISHED. RELEASED FOR PUBLICATION
 © COPYRIGHT - By - ALL RIGHTS RESERVED.

REVISIONS					
P	LTR	DESCRIPTION	DATE	DWN	APVD
	AB2	REVISED PER ECO-11-004820	11MAR11	RK	HMR
	AB3	REVISED PER ECO-17-014338	16MAY2018	RS	DR
	AB4	REVISED PER ECO-19-012963	28AUG2020	SG	DR

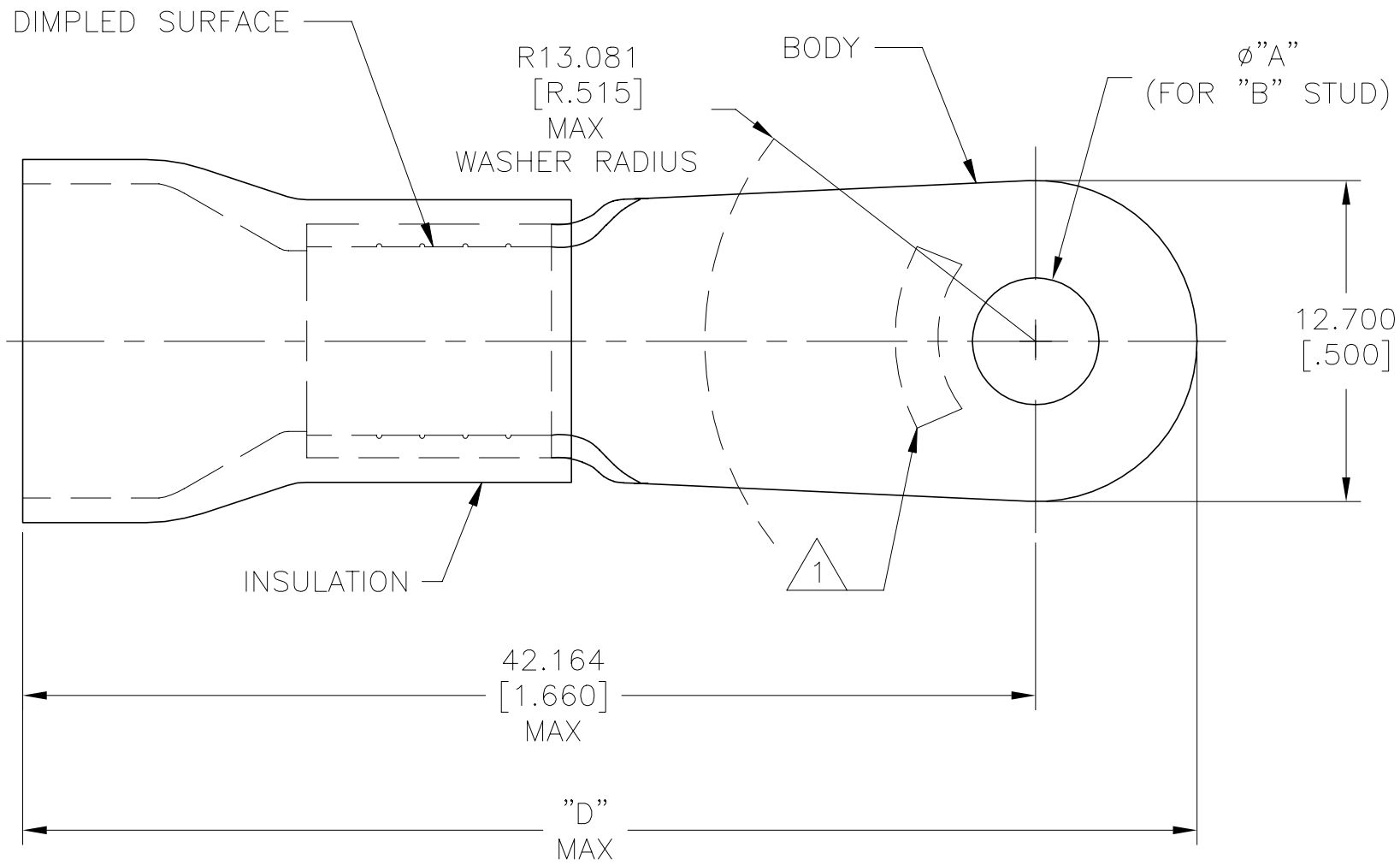

AMP WIRE RANGE	RA FILE E13288	SR LR7189 Certified
6 AWG STRANDED	6 AWG STRANDED	6 AWG STRANDED

- 1 STAMP AMP 6* LOCATE APPROX AS SHOWN
- 2 BODY MATERIAL THK 1.143±0.051[.045±.002]
- 3 SEE TABLE FOR WIRE INSULATION DIA MAX
- 4 TAPE ITEMS ARE ON 30.480[1.200] CENTERS
- 5 NOTE DELETED
- 6 NOTE DELETED

46.838 [1.844]	11.074 [.436]	#10	5.004±0.076 [.197±.003]			1-52042-0
47.473 [1.869]	9.144 [.360]	M6[1/4]	6.731 [.265]	500	ON TAPE	52042-9
46.838 [1.844]	11.074 [.436]					52042-7
47.473 [1.869]	9.144 [.360]	#10	5.004±0.076 [.197±.003]			52042-5
46.838 [1.844]	11.074 [.436]					52042-4
47.473 [1.869]	9.144 [.360]	M6[1/4]	6.731 [.265]	100	LOOSE PC	52042-3
		M4[#8]	4.343±0.076 [.171±.003]			52042-2
46.838 [1.844]	11.074 [.436]	M6[1/4]	6.731 [.265]			52042-1
		M4[#8]	4.343±0.076 [.171±.003]			52042
"D"	WIRE INSULATION DIA	"B"	"A"	QTY	PACKAGE TYPE	PART NO

AMP INCORPORATED CUSTOMER SERVICE SYSTEMS		MAX RECOMMENDED OPERATING TEMPERATURE: 105°C[221°F]
FOR ADDITIONAL PRODUCT INFORMATION OR COPIES OF DRAWINGS AND TECHNICAL DOCUMENTS	PRODUCT INFORMATION CENTER 1-800-522-6752	VOLTAGE RATING 600 V MAX
FOR APPLICATION TOOLING INFORMATION	TOOLING ASSISTANCE CENTER 1-800-722-1111	CIRCULAR MIL AREA: 10.54-16.77mm ² [20,800-33,100] STRANDED
FOR ORDER ENTRY	1-800-526-5142	THIS DRAWING IS A CONTROLLED DOCUMENT FOR AMP INCORPORATED. IT IS SUBJECT TO CHANGE AND THE CONTROLLING ENGINEERING ORGANIZATION SHOULD BE CONTACTED FOR THE LATEST REVISION.

THIS DRAWING IS A CONTROLLED DOCUMENT.	
DIMENSIONS: mm [INCHES]	TOLERANCES UNLESS OTHERWISE SPECIFIED:
	0 PLC ± - 1 PLC ± - 2 PLC ± - 3 PLC ± 0.127[.005] 4 PLC ± - ANGLES ± -
MATERIAL BODY: COPPER PER ASTM B-152 INSULATION: PVC	FINISH BODY: TIN PLATE PER ASTM B-545 INSULATION: COLOR-BLUE

DWN S.S. GOULDEN 9-29-93	STE TE Connectivity Ltd.	
CHK R. HERSEY 9-29-93	NAME TERMINAL, RING TONGUE, PLASTI-GRIP,™ WIRE SIZE: 6 AWG	
APVD B. BARE 9-29-93	APPLICATION SPEC 114-2161	
PRODUCT SPEC	SIZE A3	CAGE CODE 00779
WEIGHT	DRAWING NO C-52042	RESTRICTED TO -
CUSTOMER DRAWING	SCALE 4:1	SHEET 1 OF 1
		REV AB4