

PART NUMBER	REVISION	DESCRIPTION	FEED TYPE
2266728-1	D	FINE CRIMP HEIGHT ADJUST	MECHANICAL
2266728-2	D	FINE CRIMP HEIGHT ADJUST	PNEUMATIC
7-2266728-1	D	MECHANICAL AND CRIMP TOOLING KIT	MECHANICAL
7-2266728-2	D	PNEUMATIC AND CRIMP TOOLING KIT	PNEUMATIC
7-2266728-7	A	CRIMP TOOLING KIT	-

ATLANTIC VERSION TERMINATOR INTERFACE ADAPTER

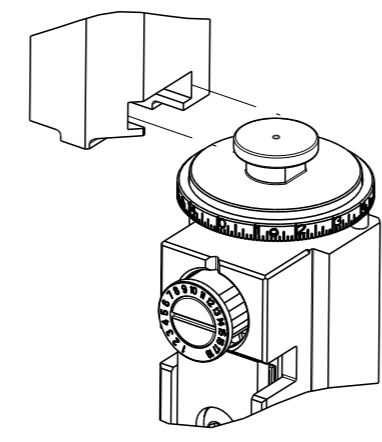

APPLICATOR DATA		
CRIMP	SIZE	TYPE
WIRE	1.98 mm [.078]	F
INSUL	4.32 mm [.170]	O

APPLICATOR INSTRUCTIONS 408-35042

TERMINAL DATA: DELPHI PACKARD TERMINAL DELPHI PACKARD CRIMP SPECIFICATION	
TERMINAL NAME: TAXI TERMINAL F M/P 280 SEALED	
WIRE STRIP LENGTH	INSULATION DIAMETER RANGE
5.20-6.00 mm [.205-.236 IN]	Ø1.60-2.15 mm [.063-.085 IN]
TERMINAL APPLICATION SPECIFICATION (A)12084201 PAGE 12 OF 42 Rev - -	
TERMINALS APPLIED	

TERMINAL DATA: DELPHI PACKARD TERMINAL DELPHI PACKARD CRIMP SPECIFICATION	
TERMINAL NAME: TAXI TERMINAL F M/P 280 SEALED	
WIRE STRIP LENGTH	INSULATION DIAMETER RANGE
5.20-6.00 mm [.205-.236 IN]	Ø1.29-1.70 mm [.051-.067 IN]
TERMINAL APPLICATION SPECIFICATION (A)12084201 PAGE 12 OF 42 Rev - -	
TERMINALS APPLIED (B)12084201 PAGE 1 OF 42 Rev - -	

TE TERMINAL	DELPHI PACKARD TERMINAL	TE SEAL	DELPHI PACKARD SEAL	CABLE DIAMETER
(A) 1949616-1	(A) 12084201	(A) 1949092-1	(A) 15324985	Ø1.6-2.15
		(A) 1949772-1	(A) 15324983	Ø1.29-1.70

TE TERMINAL	DELPHI PACKARD TERMINAL	TE SEAL	DELPHI PACKARD SEAL	CABLE DIAMETER
(B) 1949616-1	(B) 12084201	(B) 1949772-1	(B) 15324983	Ø1.29-1.70
		(B) 1949092-1	(B) 15324985	Ø1.6-2.15

WIRE SIZE	CRIMP HEIGHT mm [INCH]	CRIMP HEIGHT REFERENCE SETTING
0.50mm2	1.30+/-0.05 [.051+/-0.002]	6.5
0.35mm2	1.20+/-0.05 [.047+/-0.002]	7.6

WIRE SIZE	CRIMP HEIGHT mm [INCH]	CRIMP HEIGHT REFERENCE SETTING
0.50mm2	1.30+/-0.05 [.051+/-0.002]	6.5
0.35mm2	1.15+/-0.05 [.045+/-0.002]	8.2

- RECOMMENDED SPARE PARTS
- REFER TO SUPPLIED INSTRUCTION SHEET FOR CLEANING, LUBRICATION AND STORAGE OF APPLICATOR.
- APPLY PART NUMBER 2-23419-6 LOCTITE TO THREADS OF ITEM 242.
- CRIMP HEIGHT REFERENCE SETTING WAS THE SETTING USED WHEN THE APPLICATOR WAS QUALIFIED AT THE FACTORY. ADJUSTMENT MAY BE NECESSARY WHEN RUNNING APPLICATOR IN THE FIELD.
- APPLY TORQ-SEAL IN ALLEN SOCKET TO FILL HOLE AFTER FLAT HD HAS BEEN ADJUSTED TO CORRECT HEIGHT AT QUALIFICATION. APPLY #1-23419-5 LOC-TITE TO THREADS.
- UNLESS SPECIFIED OTHERWISE TORQUE VALUES SHALL BE USED PER DOCUMENT, 101-35000.

**\*WARNING**  
ON INSTALLATION, SET WIRE DISC TO CRIMP HEIGHT REFERENCE SETTING FOR LARGEST WIRE SIZE. CRIMP HEIGHT REFERENCE SETTINGS GREATER THAN THE VALUE SHOWN MAY CAUSE DAMAGE TO THE CRIMP TOOLING, REFER TO THE INSTRUCTION SHEET FOR PROPER SETUP AND ADJUSTMENTS.

LOC	DIST	REVISIONS			
		REV	DATE	OWN	APPV
A	66	1	18MAR2015	JH	TE
		2	31AUG2015	JH	TE
		3	05JAN2018	JAH	CT
		4	21APR2020	JAH	RR

-	1	-	1	-	2119641-1	FEED CAM, AIR FEED	248	
-	1	1	1	1	2119082-2	CAM, SNAIL, INSULATION ADJUSTMENT	244	
-	1	1	1	1	2079764-1	WASHER, WAVE SPRING, CREST-TO-CREST	243	
-	1	1	1	1	2119083-1	RETAINER, INSULATION DIAL	242	
-	1	1	1	1	7-18023-7	SCR, SKT HD CAP M3 X 4.0	241	
-	-	1	-	1	2119580-1	MECHANICAL FEED ASSEMBLY	239	
-	1	-	1	-	2844940-1	AIR FEED MODULE	238	
-	REF	REF	REF	REF	994970-2	COUNTER, MAGNETIC	164	
-	1	1	1	1	2844908-1	SCREW, LOCKING	99	
-	1	1	1	1	2844907-1	POST, LOCKING	98	
-	1	1	1	1	455888-5	SPACER, CRIMPER	82	
-	1	1	1	1	1803607-3	DOCUMENTATION PACKAGE	71	
-	1	1	1	1	2119740-1	TAG, IDENTIFICATION	67	
-	2	2	2	2	2168078-1	SCREW, DRIVE, RH, RoHS, 2 x .188	66	
-	1	1	1	1	2168083-2	SCR, SKT HD CAP, RoHS, M4 X 8.0	60	
-	1	1	1	1	5-18022-5	SCR, HEX HD CAP, M4 X 6.0	59	
-	1	1	1	1	985575-3	SCR, FLT SKT HD CAP M3 X 10.0	57	
-	1	1	1	1	1338685-1	PAWL, FEED	56	
-	4	4	4	4	2168083-3	SCR, SKT HD CAP, RoHS, M4 X 12.0	54	
-	2	2	2	2	1-2168083-0	SCR, SKT HD CAP, RoHS, M4 X 10	53	
-	1	1	1	1	5018030-1	NUT, HEX, REG, RoHS, M3	52	
-	1	1	1	1	811242-5	BUMPER, HOLD DOWN	51	
-	1	1	1	1	690753-2	SPACER, TONKER	50	
-	1	2	1	2	18023-9	SCR, SKT HD CAP M4 X 6.0	49	
-	-	1	-	1	2119652-1	FEED CAM, PRE FEED	48	
-	-	1	-	1	2119653-1	FEED CAM, POST FEED	47	
-	1	1	1	1	1803583-9	APPLICATOR BASIC ASSEMBLY, SF	46	
-	1	1	1	1	1803515-1	RAM ASSEMBLY, SF ATLANTIC	44	
-	1	1	1	1	1803602-1	SCR, BHSC, RoHS (M8 X 25)	41	
-	1	1	1	1	1752356-1	SUPPORT, TERMINAL	34	
-	2	2	2	2	2079383-5	SCR, BHSC, RoHS (M4 X 20)	33	
-	2	2	2	2	3-2844962-0	SPACER, CYLINDRICAL, STRIP GUIDE	30	
-	1	1	1	1	2844992-1	ASSEMBLY, STRIP GUIDE	29	
-	1	1	1	1	455888-3	SPACER, CRIMPER	28	
-	1	1	1	1	1320928-2	STRIP GUIDE	24	
-	1	1	1	1	2168083-2	SCR, SKT HD CAP, RoHS, M4 X 8.0	21	
-	2	2	2	2	1-18028-2	WASHER, FLAT, REG M4	20	
-	1	1	1	1	2119533-1	STRIPPER, SIDE FEED	19	
-	1	1	1	1	2119806-1	INSERT, SHEAR	13	
-	1	1	1	1	3-22280-3	SPRING, COMPRESSION	12	
-	1	1	1	1	1-356885-4	STOP, SHEAR	11	
-	1	1	1	1	2119805-1	SHEAR HOLDER, FRONT	10	
-	1	1	1	1	318707-1	FLOATING SHEAR, FRONT	9	
-	1	2	2	1	1	4-1803056-9	ANVIL, COMBINATION	8
-	-	-	-	-	-	-	7	
-	-	-	-	-	-	-	6	
-	1	1	1	1	2-2119781-4	DEPRESSOR, SHEAR	5	
-	1	1	1	1	2-238011-1	BLOCK, CRIMPER SPACER	4	
-	1	2	2	1	1	4-1633965-2	CRIMPER, INSULATION O PREMIUM	3
-	1	1	1	1	455888-4	SPACER, CRIMPER	2	
-	1	2	2	1	1	8-1633305-0	CRIMPER, WIRE PREMIUM	1

ATLANTIC VERSION  
Shown on sheets 1 of 4 & 2 of 4  
(Pacific version shown on sheets 3 of 4 & 4 of 4)

DIMENSIONS:		TOLERANCES UNLESS OTHERWISE SPECIFIED:		MATERIAL:	
mm	PLC	mm	PLC	FINISH	WEIGHT
0	PLC	±	PLC	-	-
1	PLC	±	PLC	-	-
2	PLC	±	PLC	-	-
3	PLC	±	PLC	-	-
4	PLC	±	PLC	-	-
ANGLES		±			

OWN	HOFFNER	18MAR2015
CHK	T. ELBIN	19MAR2015
APPV	T. ELBIN	19MAR2015
NAME	Ocean Side Feed Applicator	
SIZE	CAGE CODE	DRAWING NO
A1	00779	2266728
Customer Accessible Production Drawing	SCALE	1:2
SHEET	1	OF 4
REV	D	

REVOLUTIONS		DATE	OWN	APVD
LOC	DIST			
A	66			
P	LYR	DESCRIPTION		
		SEE SHEET 1		

# FEED TYPE MECHANICAL

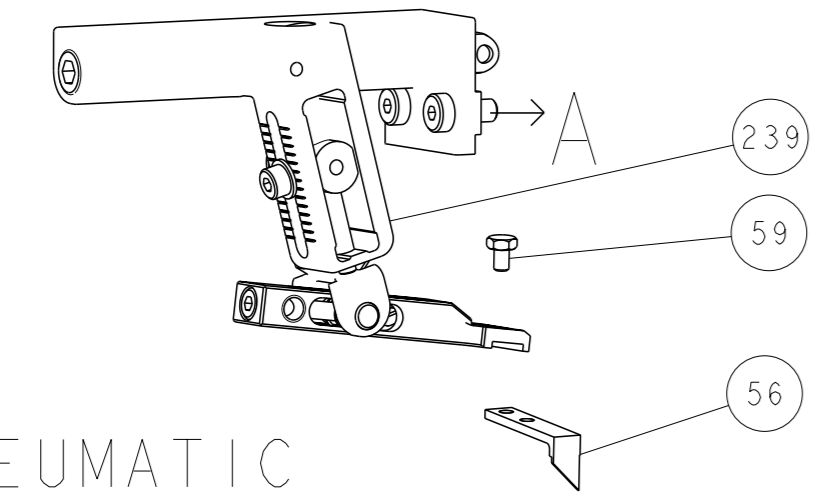

## PNEUMATIC

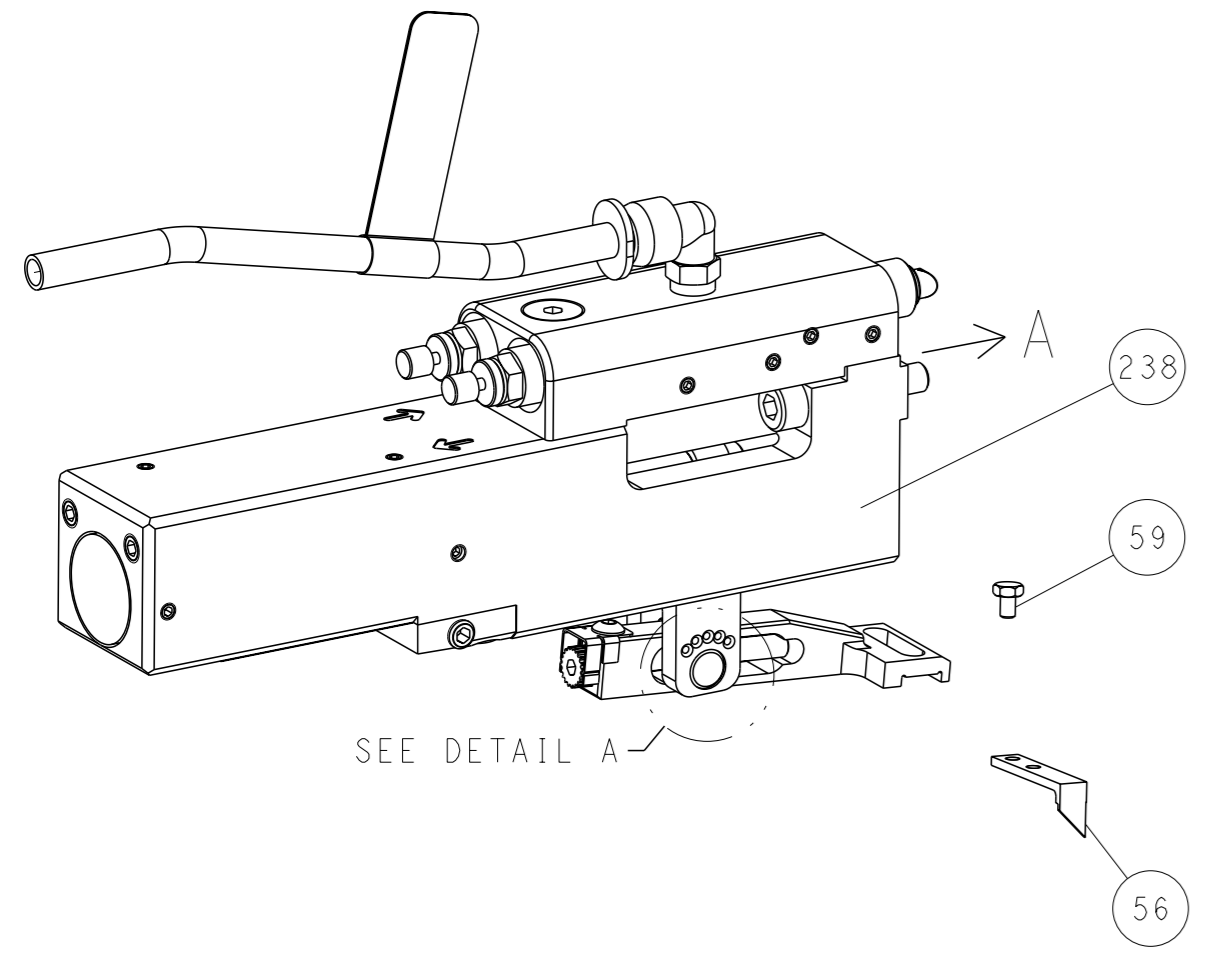

## FEED SPRING SETTING POSITION (SHOWN FROM REAR SIDE)

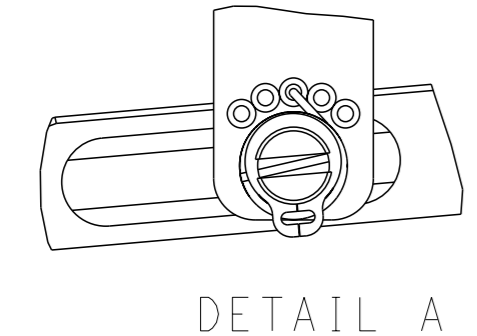

DETAIL A

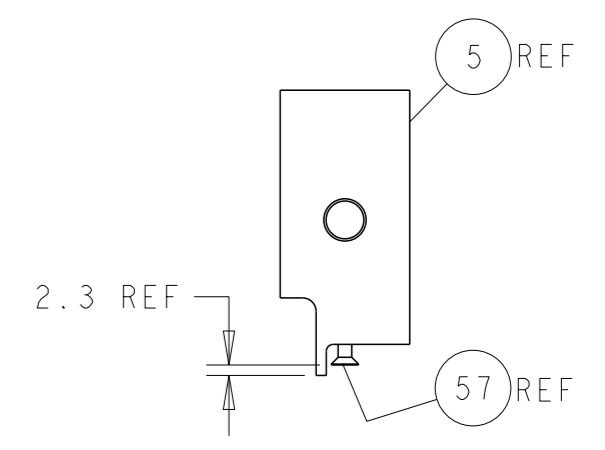
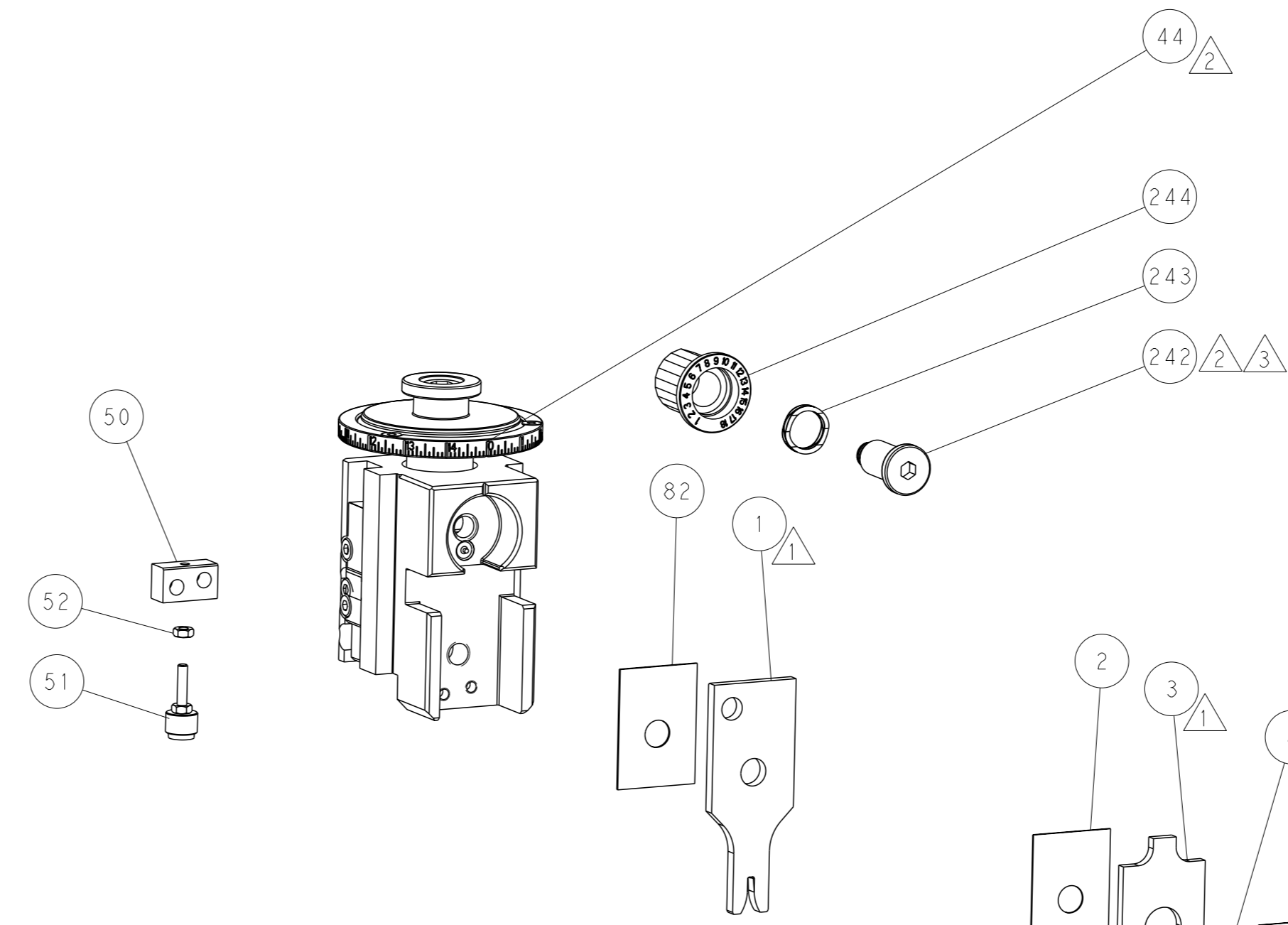
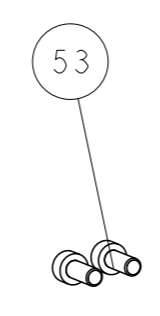

SHEAR DEPRESSOR DETAIL

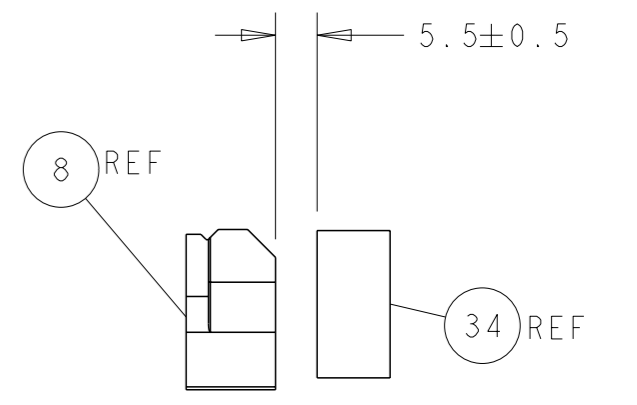

TERMINAL SUPPORT LOCATION

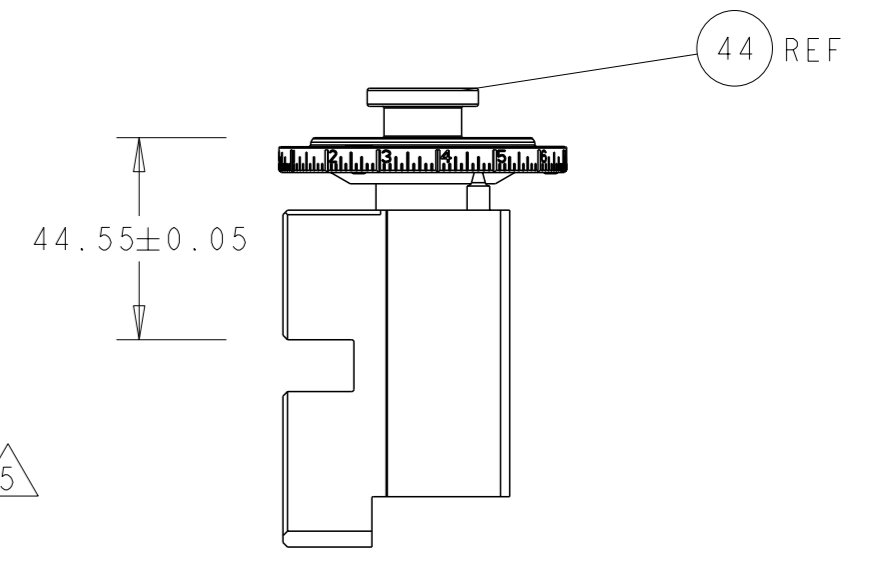

RAM SET-UP

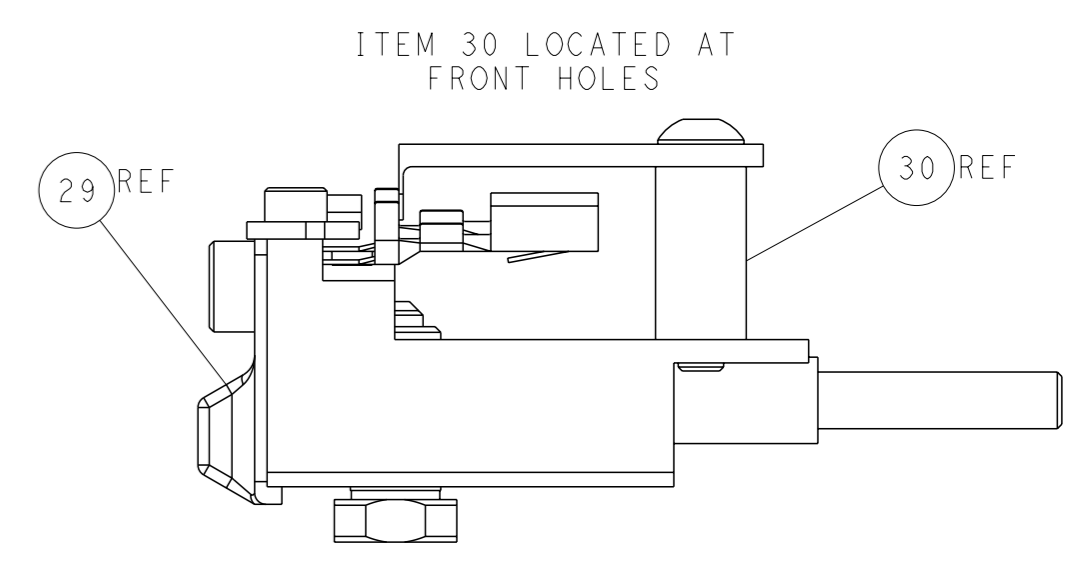
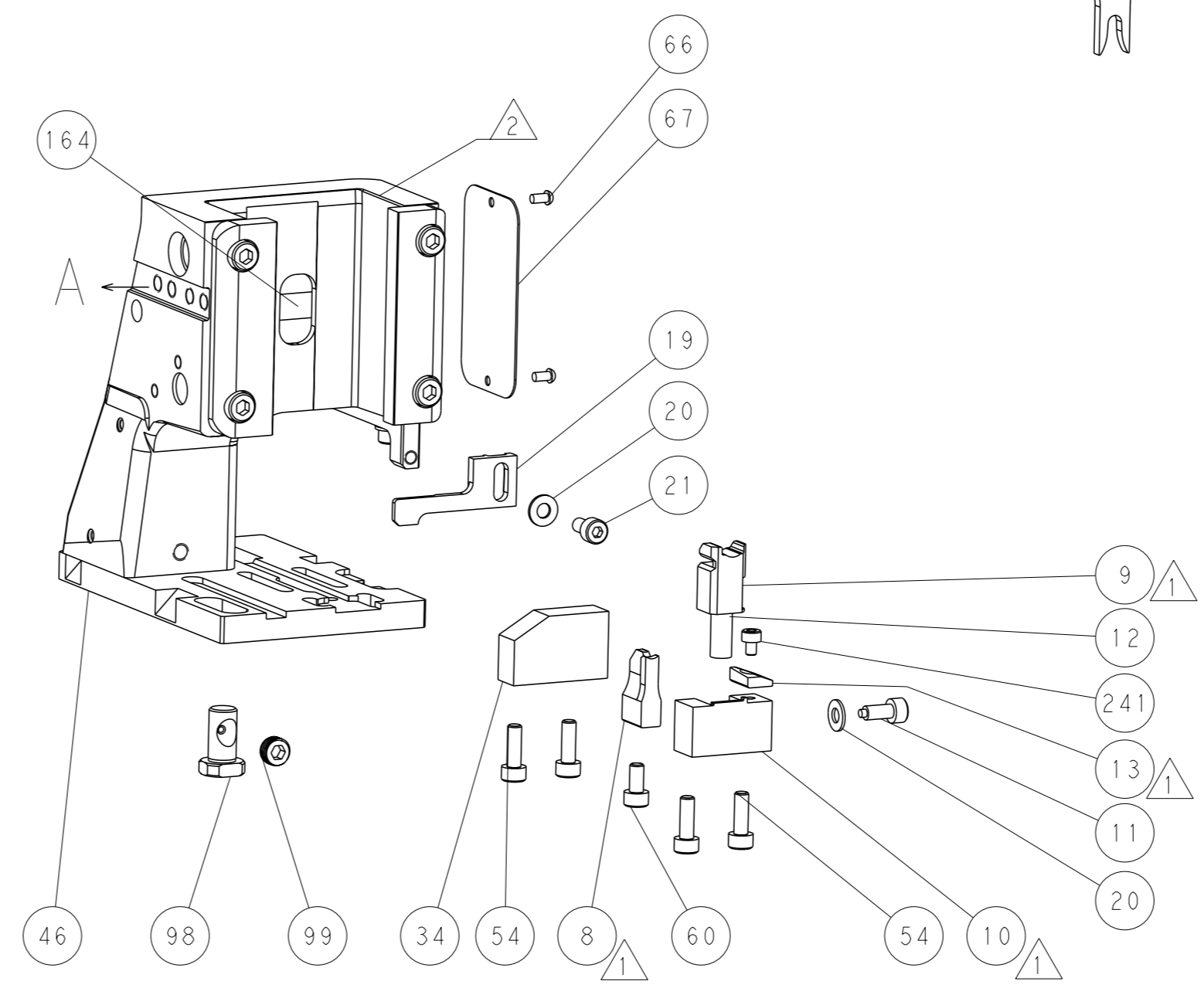
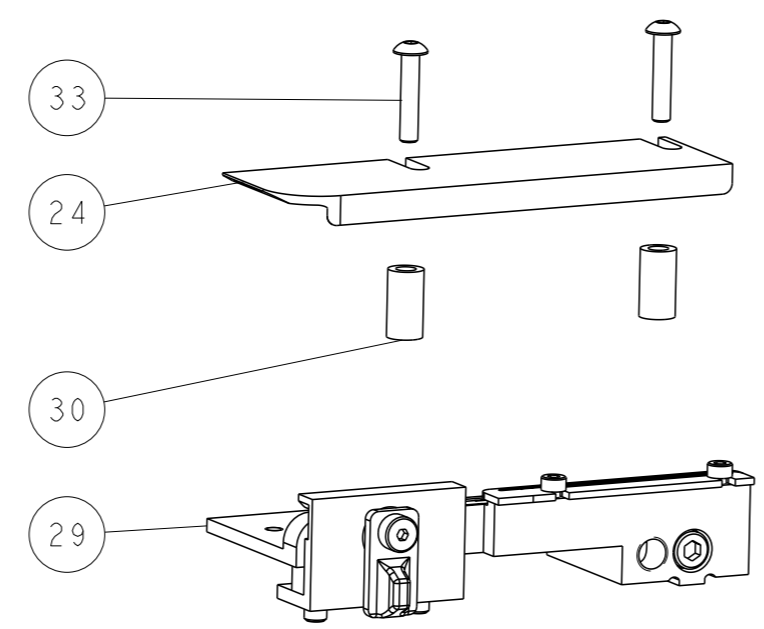

FEED TRACK POSITION GUIDE BY INSULATION BARREL

# CAM POSITIONS

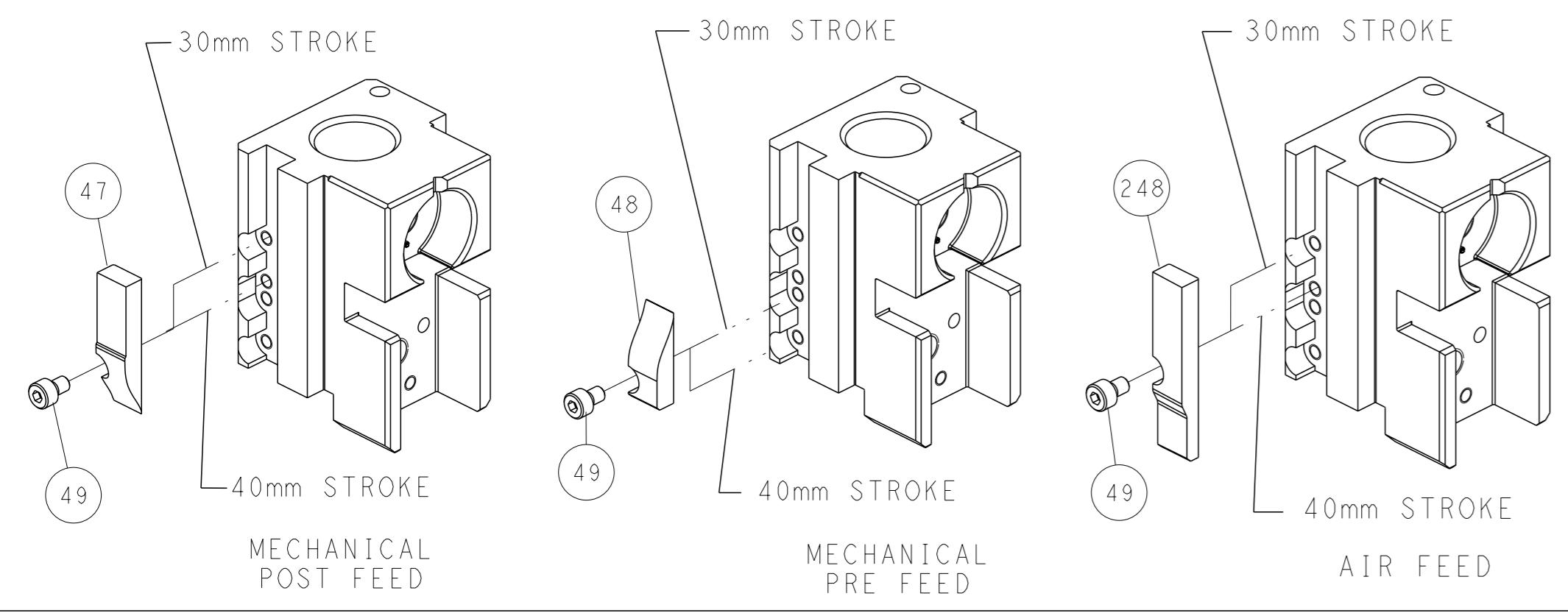

**ATLANTIC VERSION**  
 Shown on sheets 1 of 4 & 2 of 4  
 (Pacific version shown on sheets 3 of 4 & 4 of 4)

DIMENSIONS:		TOLERANCES UNLESS OTHERWISE SPECIFIED:		OWN	18MAR2015	TE Connectivity Harrisburg, PA 17105-3608
mm	0 PLC ±	1 PLC ±	2 PLC ±	HOFFNER	19MAR2015	
MATERIAL:	3 PLC ±	4 PLC ±	ANGLES	CHK	T. ELBIN	NAME Ocean Side Feed Applicator
	FINISH	APVD	WEIGHT	T. ELBIN	19MAR2015	
Customer Accessible Production Drawing		SCALE	1:2	SHEET 2 of 4		REV D

PART NUMBER	REVISION	DESCRIPTION	FEED TYPE
2-2266728-1	D	FINE CRIMP HEIGHT ADJUST	MECHANICAL
2-2266728-2	D	FINE CRIMP HEIGHT ADJUST	PNEUMATIC
7-2266728-7	A	CRIMP TOOLING KIT	-

PACIFIC VERSION TERMINATOR  
INTERFACE ADAPTER

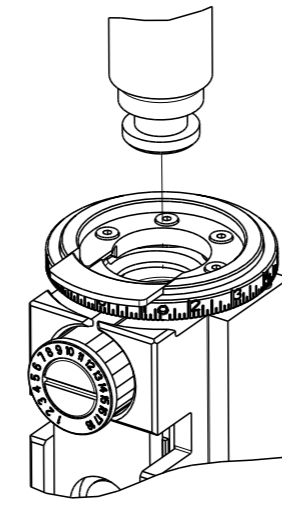

APPLICATOR DATA		
CRIMP	SIZE	TYPE
WIRE	1.98 mm [.078]	F
INSUL	4.32 mm [.170]	O
APPLICATOR INSTRUCTIONS 408-35042		

TERMINAL DATA: DELPHI PACKARD TERMINAL DELPHI PACKARD CRIMP SPECIFICATION				
TERMINAL NAME: TAXI TERMINAL F M/P 280 SEALED				
WIRE STRIP LENGTH	INSULATION DIAMETER RANGE	TE SEAL	DELPHI PACKARD SEAL	CABLE DIAMETER
5.20-6.00 mm [.205-.236 IN]	Ø1.60-2.15 mm [.063-.085 IN]	(A) 1949092-1	(A) 15324985	Ø1.6-2.15
TERMINALS APPLIED				
TE TERMINAL	DELPHI PACKARD TERMINAL	TE SEAL	DELPHI PACKARD SEAL	CABLE DIAMETER
(A) 1949616-1	(A) 12084201	(A) 1949772-1	(A) 15324983	Ø1.29-1.70

TERMINAL DATA: DELPHI PACKARD TERMINAL DELPHI PACKARD CRIMP SPECIFICATION				
TERMINAL NAME: TAXI TERMINAL F M/P 280 SEALED				
WIRE STRIP LENGTH	INSULATION DIAMETER RANGE	TE SEAL	DELPHI PACKARD SEAL	CABLE DIAMETER
5.20-6.00 mm [.205-.236 IN]	Ø1.29-1.70 mm [.051-.067 IN]	(B) 1949772-1	(B) 15324983	Ø1.29-1.70
TERMINALS APPLIED				
TE TERMINAL	DELPHI PACKARD TERMINAL	TE SEAL	DELPHI PACKARD SEAL	CABLE DIAMETER
(B) 1949616-1	(B) 12084201	(B) 1949092-1	(B) 15324985	Ø1.6-2.15

WIRE SIZE	CRIMP HEIGHT mm [INCH]	CRIMP HEIGHT REFERENCE SETTING
0.50mm2	1.30+/-0.05 [.051+/-0.002]	6.5
0.35mm2	1.20+/-0.05 [.047+/-0.002]	7.6

WIRE SIZE	CRIMP HEIGHT mm [INCH]	CRIMP HEIGHT REFERENCE SETTING
0.50mm2	1.30+/-0.05 [.051+/-0.002]	6.5
0.35mm2	1.15+/-0.05 [.045+/-0.002]	8.2

- RECOMMENDED SPARE PARTS
- REFER TO SUPPLIED INSTRUCTION SHEET FOR CLEANING, LUBRICATION AND STORAGE OF APPLICATOR.
- APPLY PART NUMBER 2-23419-6 LOCTITE TO THREADS OF ITEM 242.
- CRIMP HEIGHT REFERENCE SETTING WAS THE SETTING USED WHEN THE APPLICATOR WAS QUALIFIED AT THE FACTORY. ADJUSTMENT MAY BE NECESSARY WHEN RUNNING APPLICATOR IN THE FIELD.
- APPLY TORQ-SEAL IN ALLEN SOCKET TO FILL HOLE AFTER FLAT HD HAS BEEN ADJUSTED TO CORRECT HEIGHT AT QUALIFICATION. APPLY #1-23419-5 LOC-TITE TO THREADS.
- UNLESS SPECIFIED OTHERWISE TORQUE VALUES SHALL BE USED PER DOCUMENT, 101-35000.

**\*WARNING**  
ON INSTALLATION, SET WIRE DISC TO CRIMP HEIGHT REFERENCE SETTING FOR LARGEST WIRE SIZE. CRIMP HEIGHT REFERENCE SETTINGS GREATER THAN THE VALUE SHOWN MAY CAUSE DAMAGE TO THE CRIMP TOOLING, REFER TO THE INSTRUCTION SHEET FOR PROPER SETUP AND ADJUSTMENTS.

LOC	DIST	REV	DATE	BY	APPV
A	66				

REV	DATE	DESCRIPTION	ITEM NO		
-	1	1	2119082-2	CAM, SNAIL, INSULATION ADJUSTMENT	244
-	1	1	2079764-1	WASHER, WAVE SPRING, CREST-TO-CREST	243
-	1	1	2119083-1	RETAINER, INSULATION DIAL	242
-	1	1	7-18023-7	SCR, SKT HD CAP M3 X 4.0	241
-	-	-	2119580-1	MECHANICAL FEED ASSEMBLY	239
-	1	-	2844940-1	AIR FEED MODULE	238
-	REF	REF	994970-2	COUNTER, MAGNETIC	164
-	1	-	2119641-2	FEED CAM, AIR FEED	151
-	1	1	2168083-8	SCR, SKT HD CAP, RoHS, M4 X 16	144
-	4	4	2168083-9	SCR, SKT HD CAP, RoHS, M4 X 20	143
-	-	-	2119653-2	FEED CAM, POST FEED	142
-	1	1	1-1803583-0	APPLICATOR BASIC ASSEMBLY, SF	141
-	1	1	1803516-1	RAM ASSEMBLY, SF PACIFIC	140
-	1	1	2844908-1	SCREW, LOCKING	99
-	1	1	2844907-1	POST, LOCKING	98
-	1	1	455888-5	SPACER, CRIMPER	82
-	1	1	1803607-3	DOCUMENTATION PACKAGE	71
-	1	1	2119740-1	TAG, IDENTIFICATION	67
-	2	2	2168078-1	SCREW, DRIVE, RH, RoHS, 2 x .188	66
-	1	1	5-18022-5	SCR, HEX HD CAP, M4 X 6.0	59
-	1	1	985575-3	SCR, FLT SKT HD CAP M3 X 10.0	57
-	1	1	1338685-1	PAWL, FEED	56
-	2	2	1-2168083-0	SCR, SKT HD CAP, RoHS, M4 X 10	53
-	1	1	5018030-1	NUT, HEX, REG, RoHS, M3	52
-	1	1	811242-5	BUMPER, HOLD DOWN	51
-	1	1	690753-2	SPACER, TONKER	50
-	1	2	18023-9	SCR, SKT HD CAP M4 X 6.0	49
-	-	-	2119652-1	FEED CAM, PRE FEED	48
-	1	1	1803602-1	SCR, BHSC, RoHS (M8 X 25)	41
-	1	1	1752356-1	SUPPORT, TERMINAL	34
-	2	2	2079383-5	SCR, BHSC, RoHS (M4 X 20)	33
-	2	2	3-2844962-0	SPACER, CYLINDRICAL, STRIP GUIDE	30
-	1	1	2844992-1	ASSEMBLY, STRIP GUIDE	29
-	1	1	455888-3	SPACER, CRIMPER	28
-	1	1	1320928-2	STRIP GUIDE	24
-	1	1	2168083-2	SCR, SKT HD CAP, RoHS, M4 X 8.0	21
-	2	2	1-18028-2	WASHER, FLAT, REG M4	20
-	1	1	2119533-1	STRIPPER, SIDE FEED	19
-	1	1	2119806-1	INSERT, SHEAR	13
-	1	1	3-22280-3	SPRING, COMPRESSION	12
-	1	1	1-356885-4	STOP, SHEAR	11
-	1	1	2119805-1	SHEAR HOLDER, FRONT	10
-	1	1	318707-1	FLOATING SHEAR, FRONT	9
-	1	1	4-1803056-9	ANVIL, COMBINATION	8
-	-	-	-	-	7
-	-	-	-	-	6
-	1	1	2-2119781-4	DEPRESSOR, SHEAR	5
-	1	1	2-238011-1	BLOCK, CRIMPER SPACER	4
-	1	1	4-1633965-2	CRIMPER, INSULATION O PREMIUM	3
-	1	1	455888-4	SPACER, CRIMPER	2
-	1	1	8-1633305-0	CRIMPER, WIRE PREMIUM	1

PACIFIC VERSION  
Shown on sheets 3 of 4 & 4 of 4  
(Atlantic version shown on sheets 1 of 4 & 2 of 4)

DIMENSIONS:	TOLERANCES UNLESS OTHERWISE SPECIFIED:	APPROVED:	DATE:	DESCRIPTION:	ITEM NO:
mm	0 PLC ± 1 PLC ± 2 PLC ± 3 PLC ± 4 PLC ± ANGLES ±	OWN: HOFFNER CHK: T. ELBIN APPV: T. ELBIN	18MAR2015 19MAR2015 19MAR2015	TE Connectivity Harrisburg, PA 17105-3608	
MATERIAL:		APPLICATOR SPEC:		Customer Accessible Production Drawing	
FINISH:		WEIGHT:		SCALE: 1:2 SHEET 3 of 4 REV D	
SIZE:		CAGE CODE:		DRAWING NO: 00779 C=2266728	

LOC	DIST	REVISIONS			
A	66	REV	DATE	OWN	APVD
		1	SEE SHEET 1		

# FEED TYPE MECHANICAL

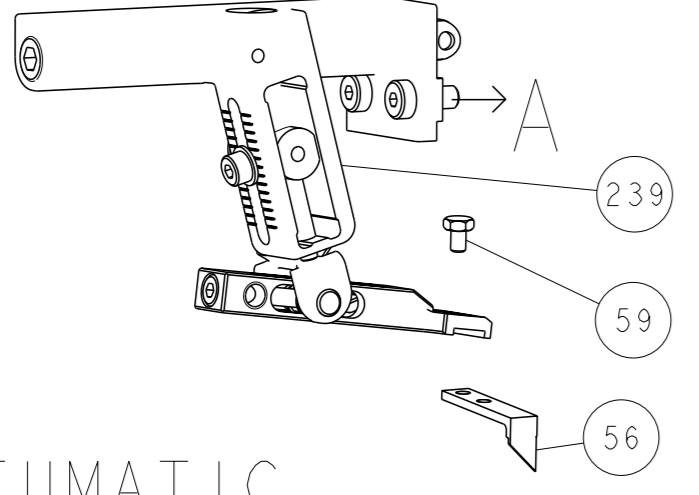

# PNEUMATIC

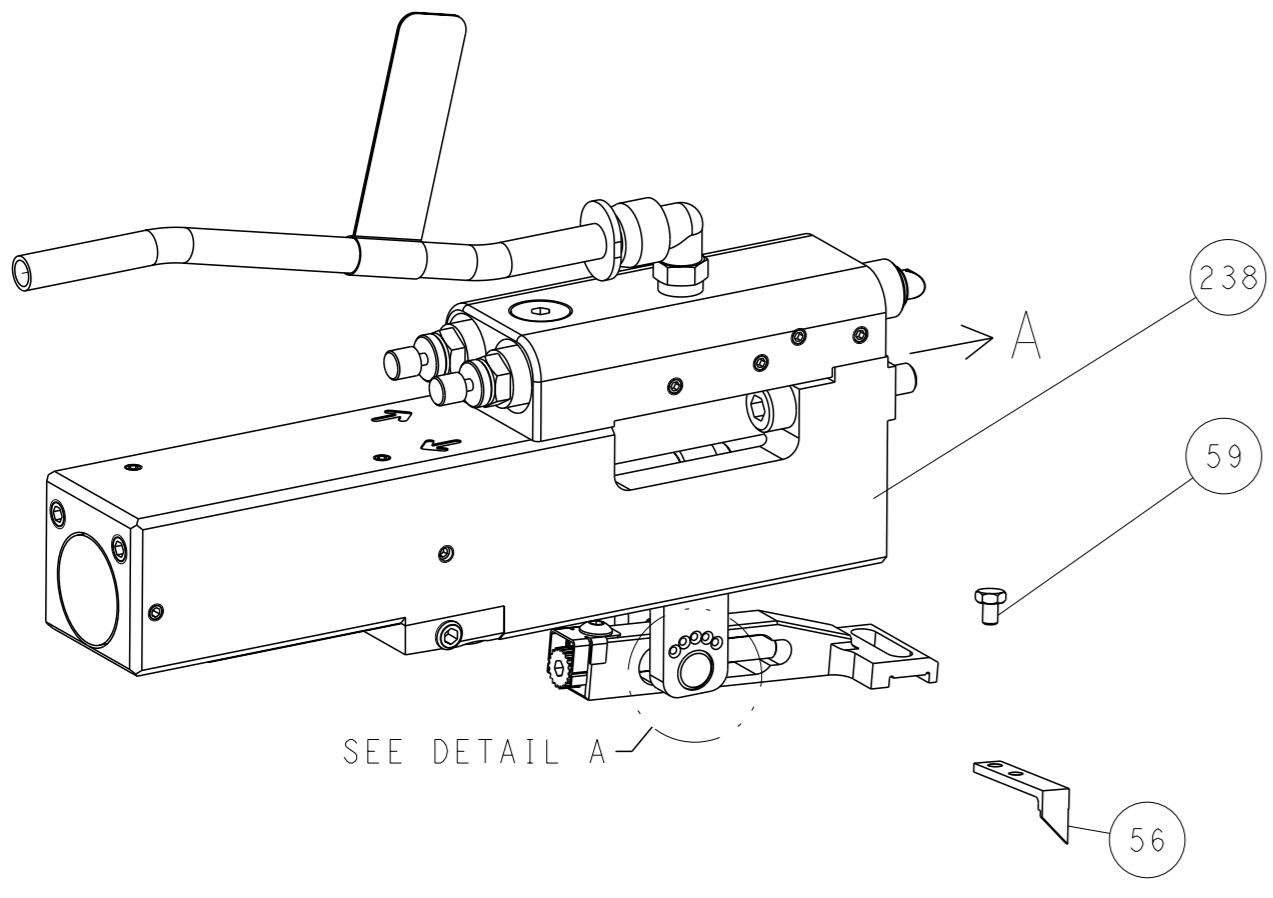

FEED SPRING SETTING POSITION  
(SHOWN FROM REAR SIDE)

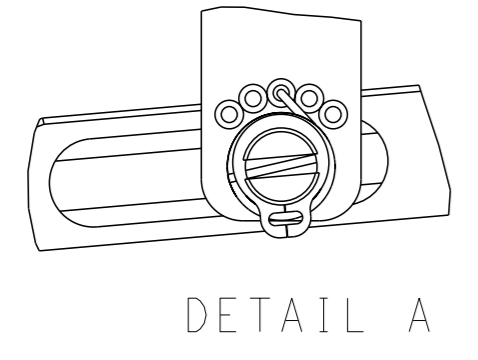

# CAM POSITIONS

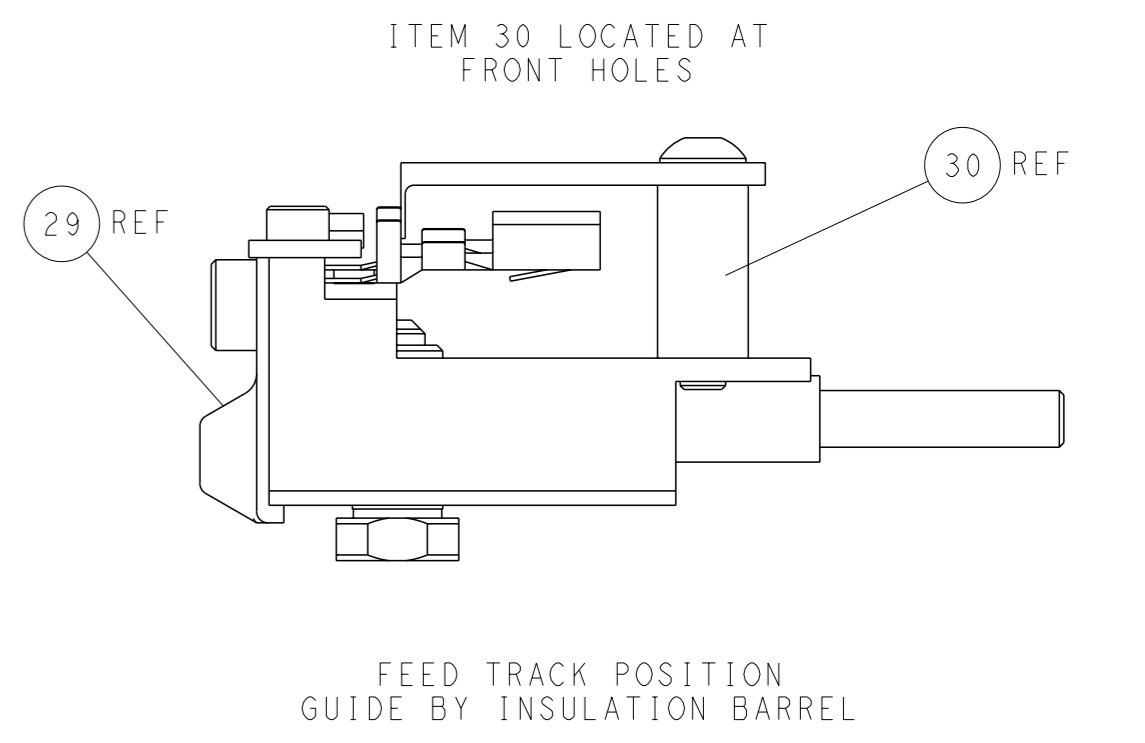
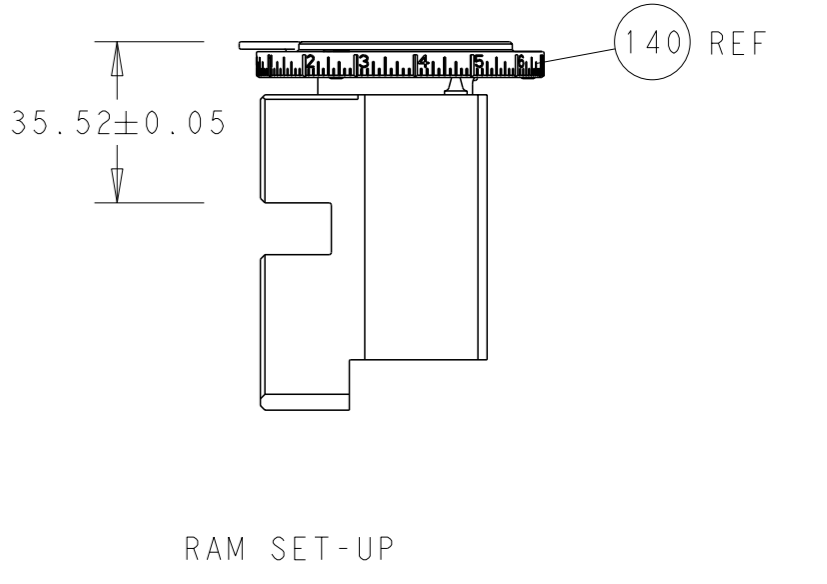
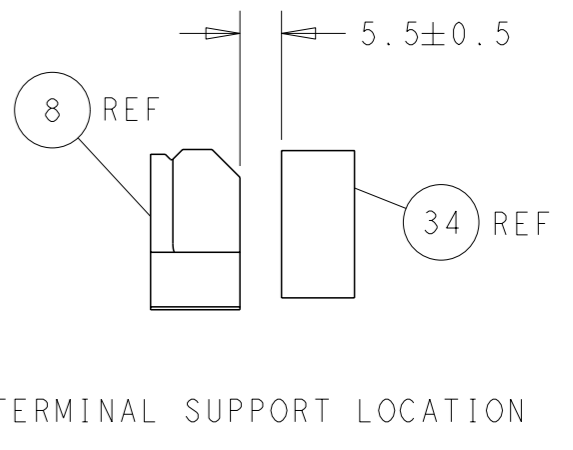
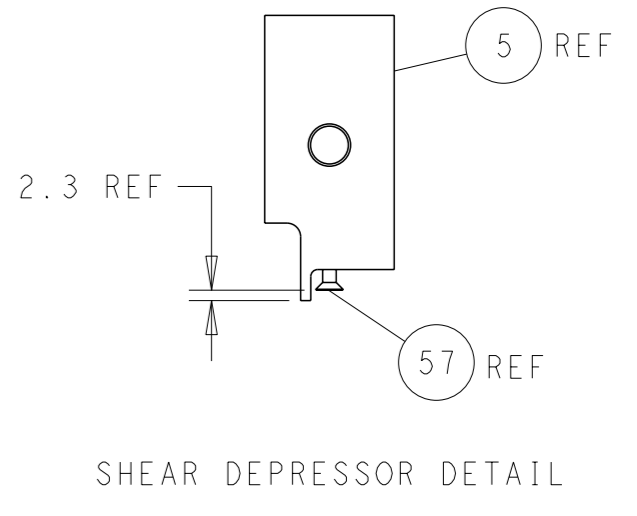
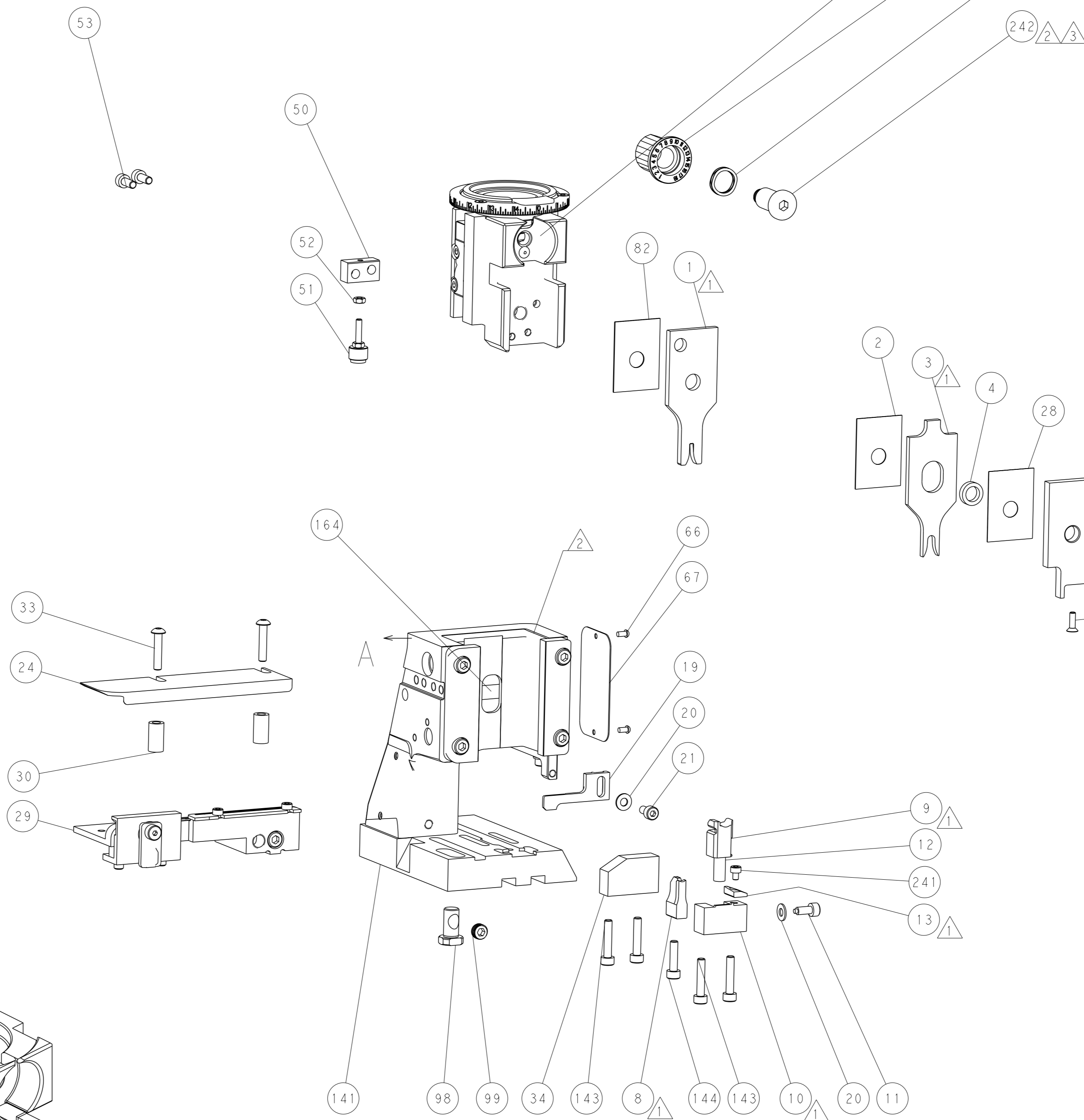
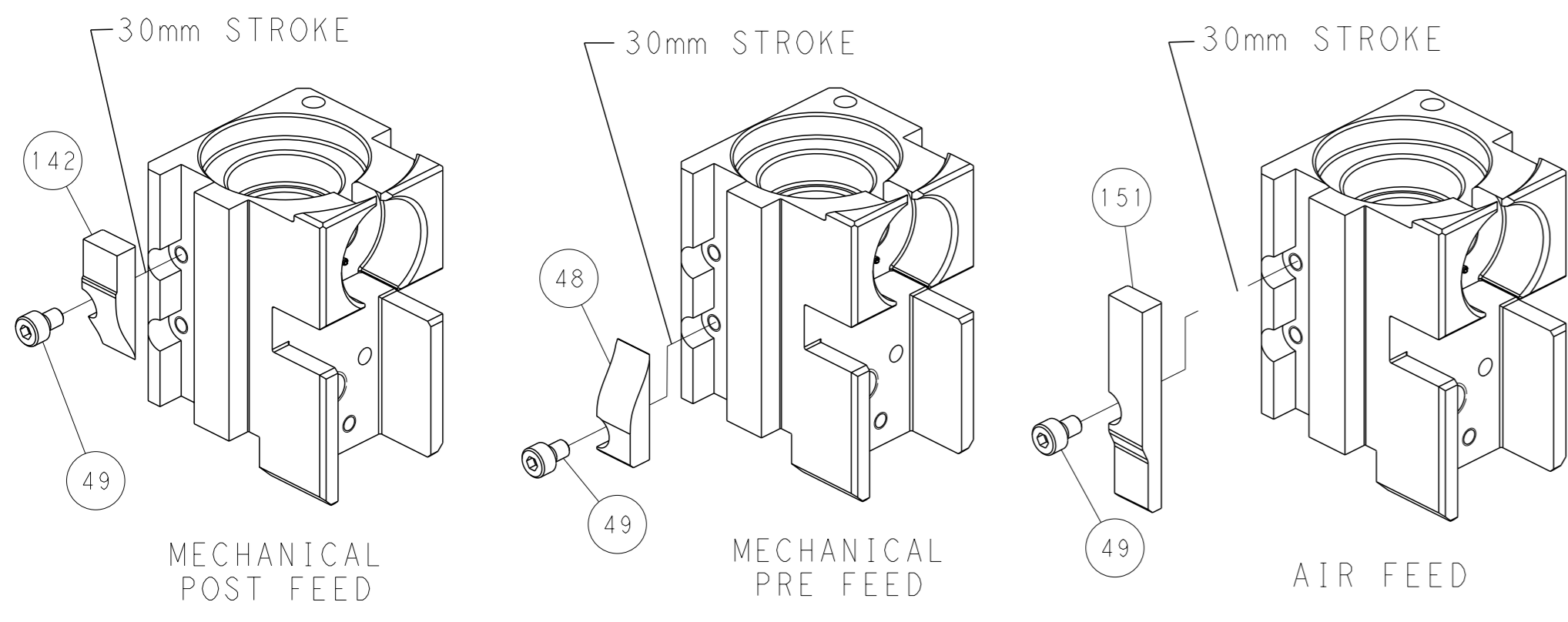

**PACIFIC VERSION**  
 Shown on sheets 3 of 4 & 4 of 4  
 (Atlantic version shown on sheets 1 of 4 & 2 of 4)

<small>THIS DRAWING IS A CONTROLLED DOCUMENT FOR TYCO ELECTRONICS CORPORATION. IT IS SUBJECT TO CHANGE AND THE CONTROLLER'S ENGINEERING ORGANIZATION SHOULD BE CONTACTED FOR THE LATEST REVISION.</small>		OWN: HOFFNER 18MAR2015 CHK: T. ELBIN 19MAR2015 APVD: T. ELBIN 19MAR2015	TE Connectivity Harrisburg, PA 17105-3608
DIMENSIONS: mm TOLERANCES UNLESS OTHERWISE SPECIFIED: 0 PLC ± 1 PLC ± 2 PLC ± 3 PLC ± 4 PLC ± ANGLES FINISH *		NAME: Ocean Side Feed Applicator APPLICATION SPEC: - SIZE: A1 CAGE CODE: 00779 DRAWING NO: C=2266728	RESTRICTED TO: - SCALE: 1:2 SHEET: 4 of 4 REV: D
MATERIAL: - FINISH: -		WEIGHT: - Customer Accessible Production Drawing	SHEETS 1 & 2 ARE NOT REQUIRED FOR PACIFIC VERSION