

PRODUCT NUMBER	PEG TYPE	TAIL TYPE	TAIL LGTH. DIM "A"	PCB THICKNESS	LOADING CONFIGURATION
89095-X02LF	PRESS	PRESS-FIT	2.90	1.6	FULLY LOADED
89095-X12LF	PRESS	PRESS-FIT	3.53	2.4	

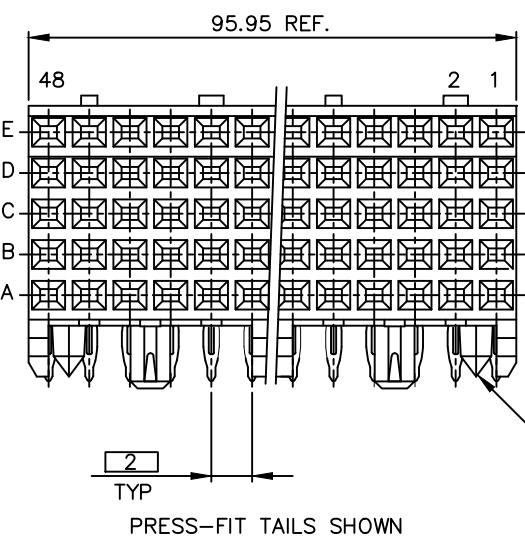

REFER NOTE-2
89095-XYLFF

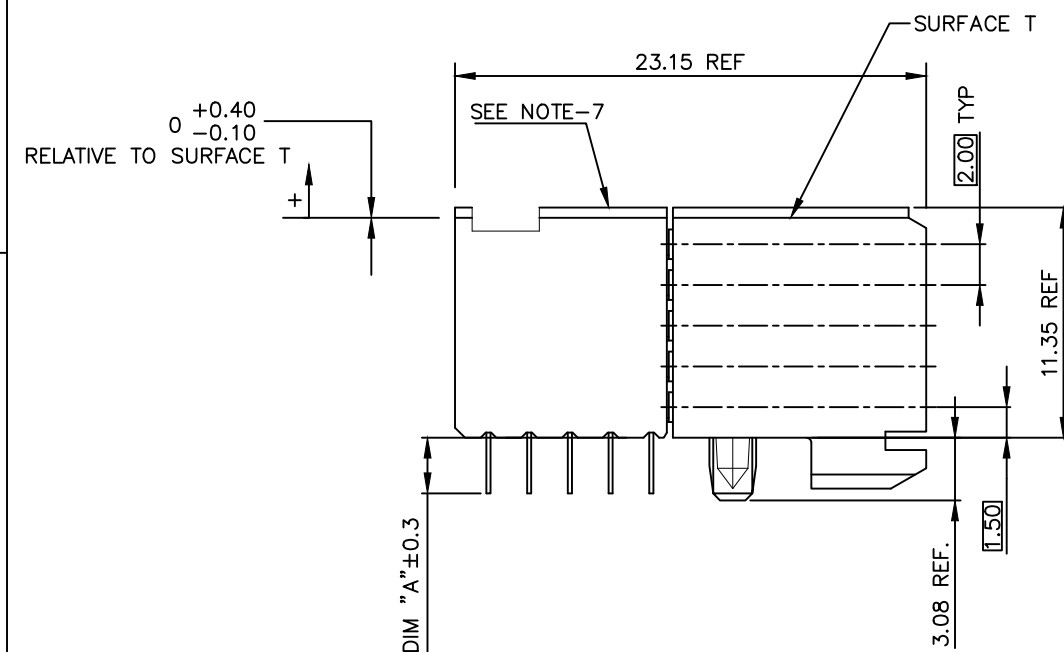
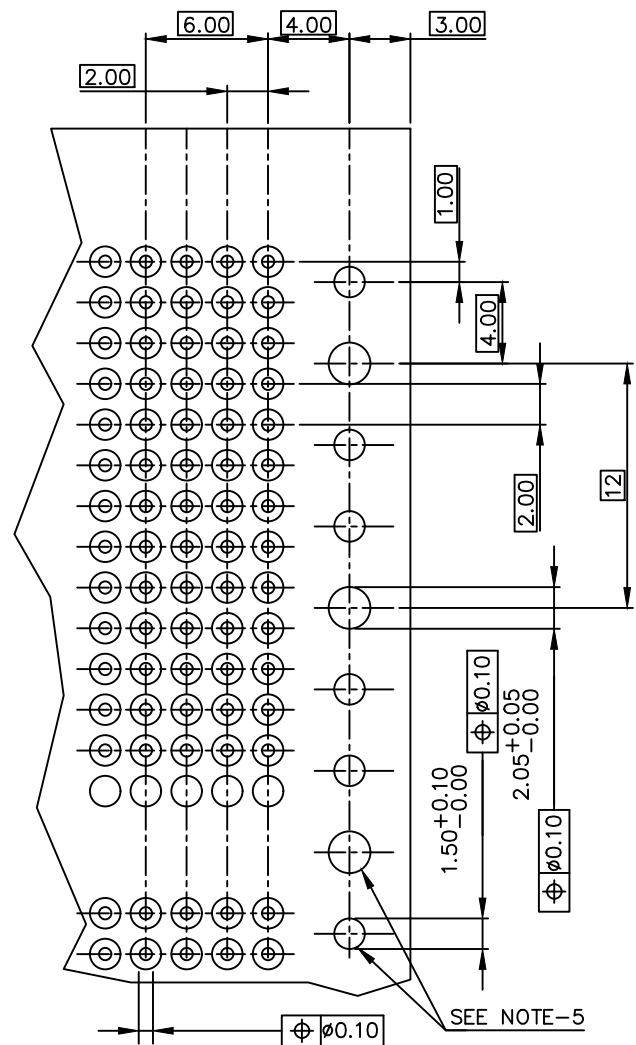

RECOMMENDED PC BOARD LAYOUT, COMPONENT SIDE.
FOR PTH DIMENSIONS REFER DRAWING NO : 58351.

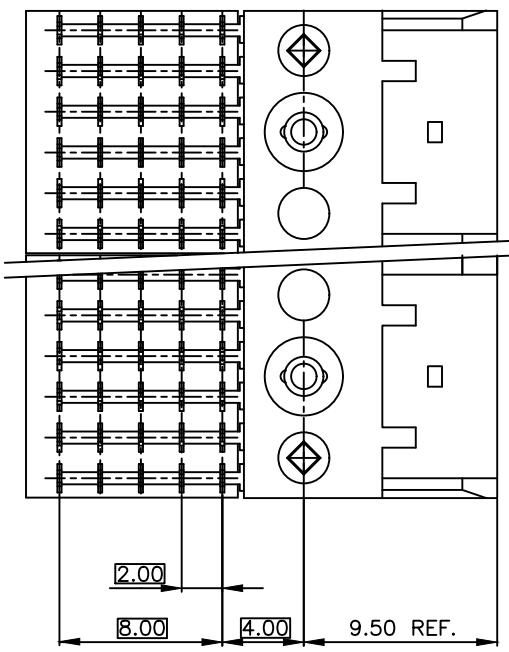

NOTES:

- MATERIAL : BODY : LCP UL94-V0
: CONTACT : COPPER ALLOY.
: PRESS BLOCK : GF, HIGH TEMPERATURE RESIN UL 94-V0 COMPLIANT
- FOR PLATING PERFORMANCE REFER DRAWING # 10159408
- PRODUCT SPECIFICATION : GS-12-002
- APPLICATION SPECIFICATIONS : BUS-20-061 , GS-20-001,TA-941
- INDICATED HOLES ARE UNPLATED
- DIAMOND LOCATION PEG ARE ONLY EXISTED ON THE BOTH SIDES OF PRODUCT.
- TOP SURFACE OF PRESS BLOCK MAY EXTEND UP TO 0.4MM HIGHER THAN HOUSING. THIS MAY AFFECT THE TAIL LENGTH BEFORE APPLICATION TO A BOARD.
- THIS PRODUCT MEETS EUROPEAN UNION DIRECTIVES AND OTHER COUNTRY REGULATIONS AS DESCRIBED IN GS-47- 0004
- ALL PRODUCTS WILL WITHSTAND EXPOSURE TO 240°C FOR 60 SECONDS BIN A CONVECTION, INFAR-RED OR VAPOR PHASE REFLOW OVEN.
- A Δ SYMBOL WILL BE NEXT TO ANY DIMENSION, VIEW, OR NOTE WHICH HAS BEEN MODIFIED WITH THE CURRENT DRAWING REVISION.

Amphenol FCI

© 2016 AFCI

mat'l. code				surface	tolerance	projection	product family		
				ISO 1302	ISO 406 ISO 1101		METRAL		
ltr	ecn no	dr	date	tolerances unless otherwise specified			title		
R	DG08-0171	TER	2008-07-07	angles	linear	.X±0.3	B SERIES R/A SIGNAL RECEPT ASSY,		
S	DG09-0068	CENH	2009-06-06			.XX±0.13	5 ROW, 8 MOD, PF		
T	ELX-I-38915	MINI	2020-10-27	0°±2°		.XXX±0.050	sheet 1 of 1 size		
				dr	C. DAILY	2002-06-18	89095		
				enr	ARUN	2020-10-27	A3		
				chr	ALEX BABU	2020-10-27	type		
				app	SANOJ	2020-10-27	Product Customer Drawing		
sheet index	revision sheet	T	1						