

### Features

- 2 Differential Channel, 4:1 Mux/DeMux
- PCI Express® 2.0 performance, 5.0 Gbps
- Low Bit-to-Bit Skew, 7ps Max.
- Low Crosstalk: -23dB@3GHz
- Low Off Isolation: -23dB@3GHz
- V<sub>DD</sub> Operating Range: +1.8V ±10%
- ESD Tolerance 2kV HBM on data I/O
- Packaging (Pb-free & Green):
  - 42 contact TQFN

### Description

Pericom Semiconductor's PI2PCIE2214 is a 8 to 2 differential channel multiplexer/demultiplexer switch. Due to its low bit-to-bit skew, high channel-to-channel noise isolation and high bandwidth, this product is ideal for PCI Express® switching to 5.0 Gbps.

### Application

Switch a PCI Express® lane output between four PCI Express lane inputs

### Block Diagram

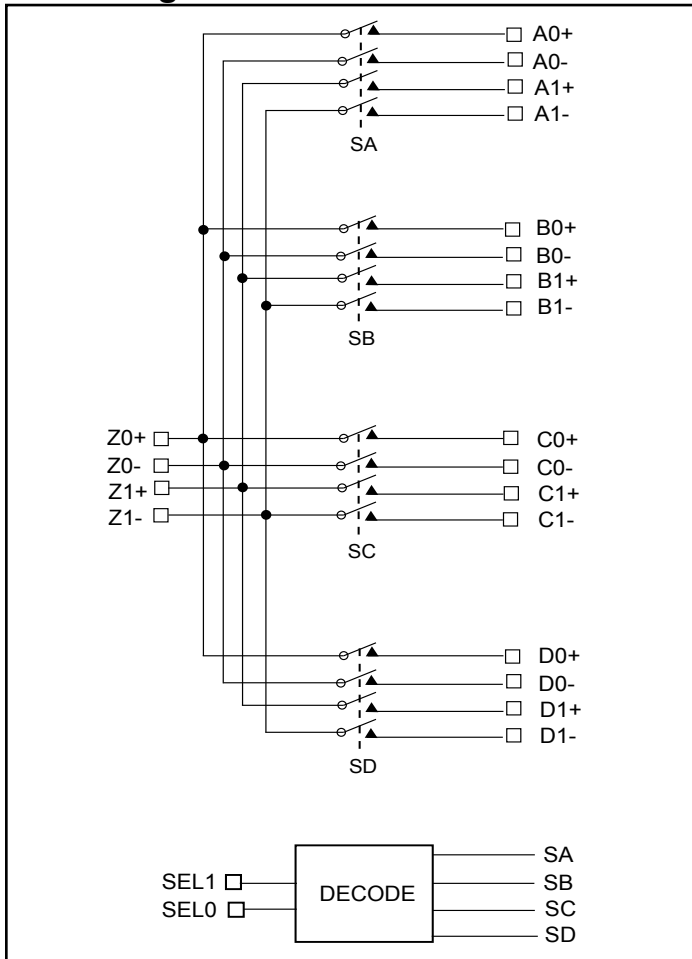

### Pin Description

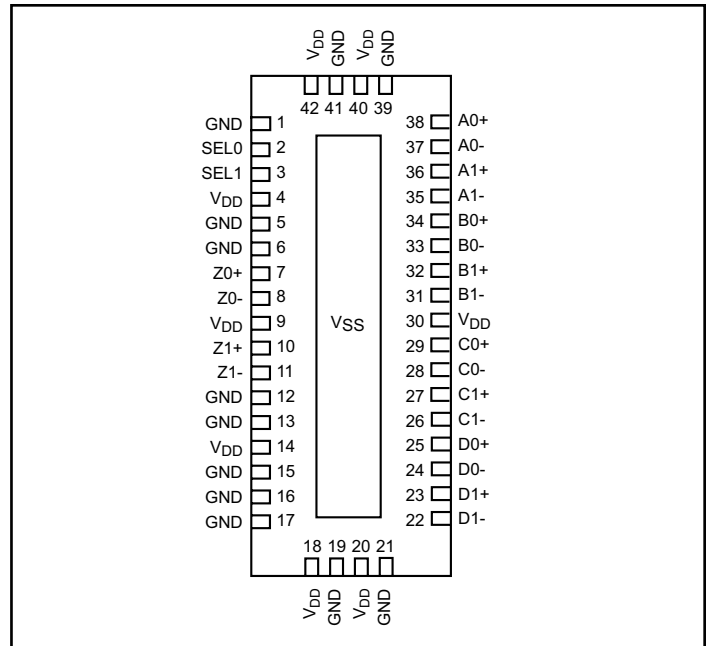

### Truth Table

SEL1	SEL0	FUNCTION
0	0	Z to A
0	1	Z to B
1	0	Z to C
1	1	Z to D

## Maximum Ratings

(Above which useful life may be impaired. For user guidelines, not tested.)

Storage Temperature .....	-65°C to +150°C
Supply Voltage to Ground Potential .....	-0.5V to +2.5V
DC Input Voltage .....	-0.5V to +V <sub>DD</sub>
DC Output Current .....	120mA
Power Dissipation .....	0.5W

**Note:** Stresses greater than those listed under MAXIMUM RATINGS may cause permanent damage to the device. This is a stress rating only and functional operation of the device at these or any other conditions above those indicated in the operational sections of this specification is not implied. Exposure to absolute maximum rating conditions for extended periods may affect reliability.

## Power Supply Characteristics

Parameters	Description	Test Conditions <sup>(1)</sup>	Min.	Typ. <sup>(2)</sup>	Max.	Units
I <sub>DD</sub>	Quiescent Power Supply Current	V <sub>DD</sub> = Max., V <sub>IN</sub> = GND or V <sub>DD</sub>			300	μA

**Notes:**

- For Max. or Min. conditions, use appropriate value specified under Electrical Characteristics for the applicable device type.
- Typical values are at V<sub>DD</sub> = 1.8V, T<sub>A</sub> = 25°C ambient and maximum loading.

## DC Electrical Characteristics for Switching over Operating Range

(T<sub>A</sub> = -40°C to +85°C, V<sub>DD</sub> = 1.8V ± 10%)

Parameter	Description	Test Conditions	Min.	Typ. <sup>(2)</sup>	Max.	Units
V <sub>IH</sub>	Input HIGH Voltage	Guaranteed HIGH level	0.65 x V <sub>DD</sub>	-	-	V
V <sub>IL</sub>	Input LOW Voltage	Guaranteed LOW level	-	-	0.35 x V <sub>DD</sub>	
V <sub>IK</sub>	Clamp Diode Voltage	V <sub>DD</sub> = Max., I <sub>IN</sub> = -18mA	-	-0.7	-1.2	
I <sub>IH</sub>	Input HIGH Current	V <sub>DD</sub> = Max., V <sub>IN</sub> = V <sub>DD</sub>	-	-	±5	μA
I <sub>IL</sub>	Input LOW Current	V <sub>DD</sub> = Max., V <sub>IN</sub> = GND	-	-	±5	

## Switching Characteristics (T<sub>A</sub> = -40° to +85°C, V<sub>DD</sub> = 1.8V ± 10%)

Parameter	Description	Min.	Typ. <sup>(2)</sup>	Max.	Units
t <sub>PZH</sub> , t <sub>PZL</sub>	Line Enable Time - SEL to A <sub>N</sub> , B <sub>N</sub>	0.5	-	8.0	ns
t <sub>PHZ</sub> , t <sub>PLZ</sub>	Line Disable Time - SEL to A <sub>N</sub> , B <sub>N</sub>	0.5	-	10	
t <sub>b-b</sub>	Bit-to-bit skew within the same differential pair		7		ps
t <sub>ch-ch</sub>	Channel-to-channel skew		35		ps

**Notes:**

- For max. or min. conditions, use appropriate value specified under Electrical Characteristics for the applicable device type.

## Dynamic Electrical Characteristics Over the Operating Range

(T<sub>A</sub> = -40° to +85°C, V<sub>DD</sub> = 1.8V ± 10%)

Parameter	Description	Test Conditions <sup>(1)</sup>	Min.	Typ. <sup>(2)</sup>	Max.	Units
X <sub>TALK</sub>	Crosstalk	f = 2.5 GHz		-40		dB
O <sub>IRR</sub>	OFF Isolation	f = 2.5 GHz		-25		dB
I <sub>LOSS</sub>	Differential Insertion Loss	f = 2.5 GHz		-3.0		dB
BW	Bandwidth -3dB			2.6		GHz

**Notes:**

- Guaranteed by design.
- Typical values are at V<sub>DD</sub> = 1.8V, T<sub>A</sub> = 25°C ambient and maximum loading.

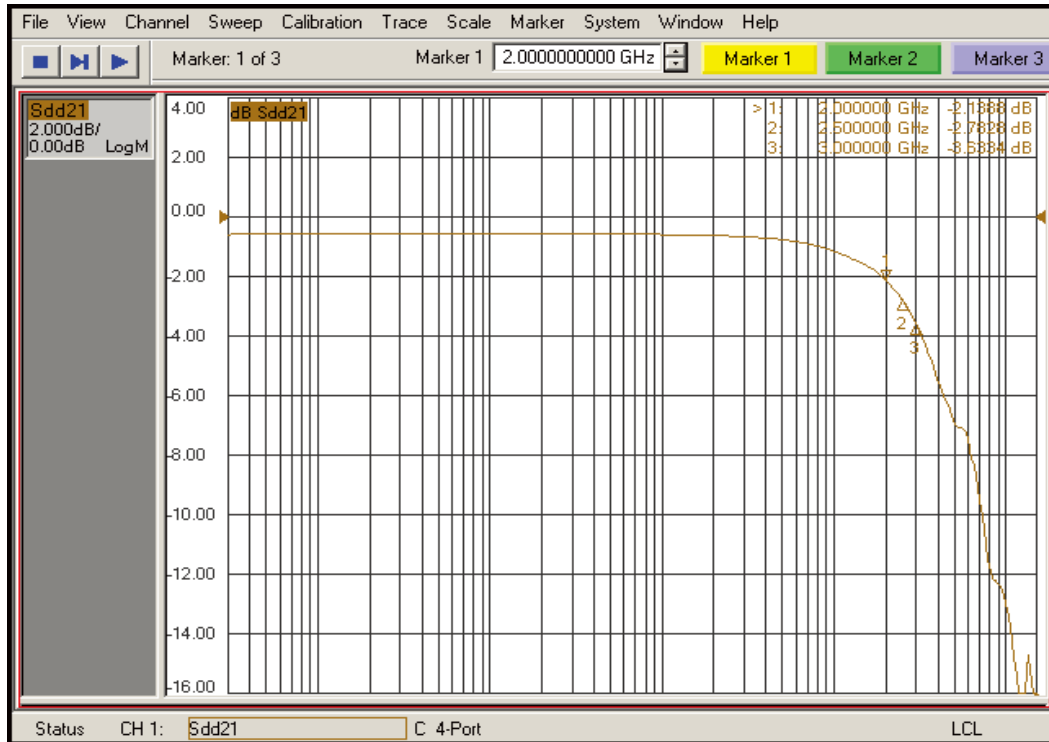

**Insertion Loss**

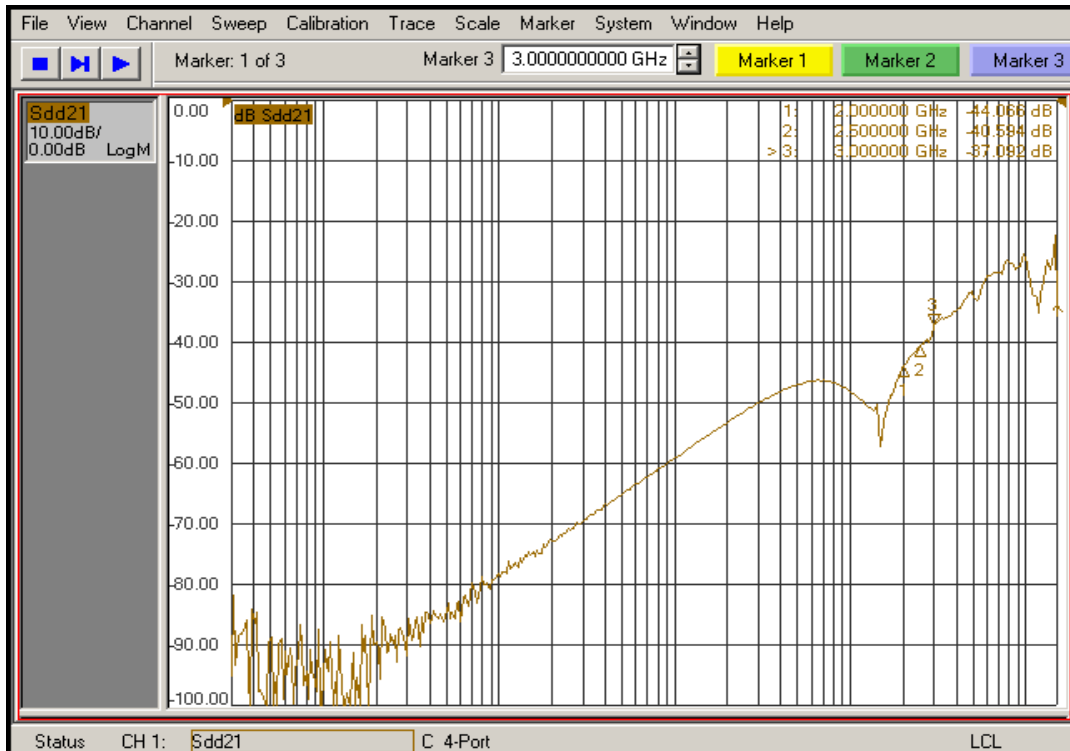

**Crosstalk**

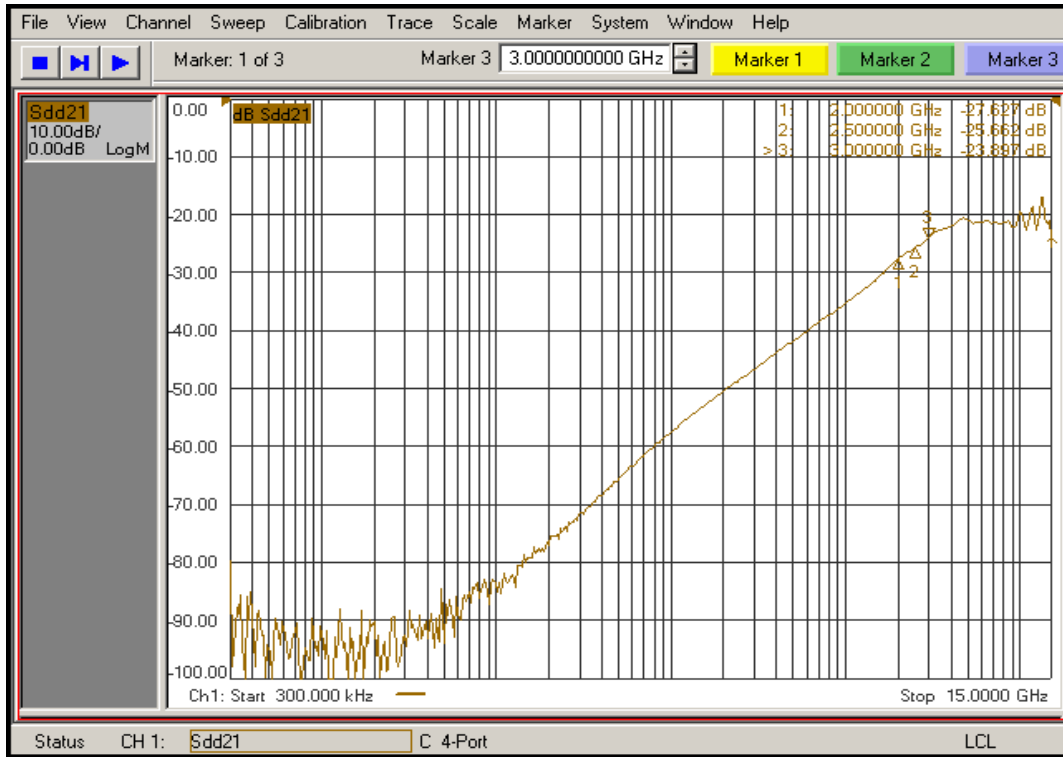

**Off Isolation**

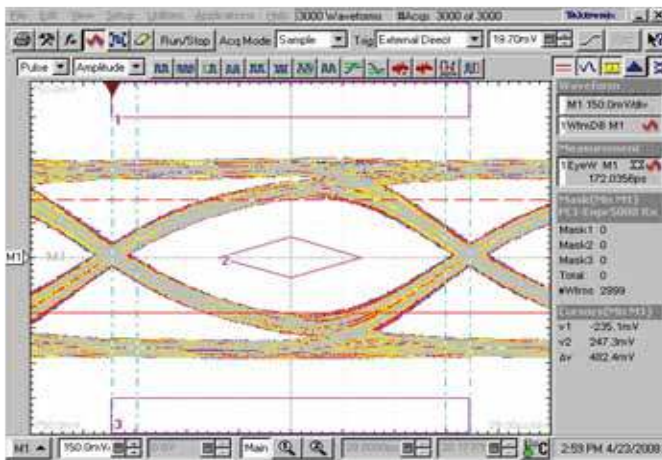

**Signal Eye with Switch**

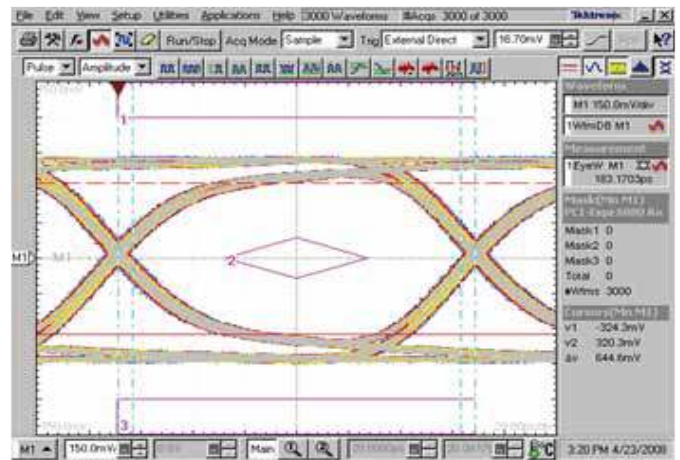

**Signal Eye without Switch**

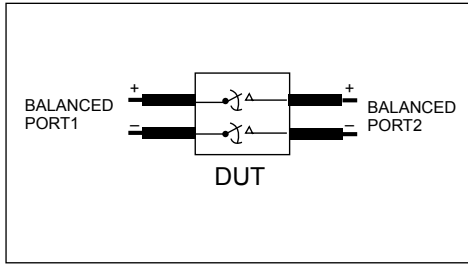

**Diff. Insertion Loss and Return Test Circuit**

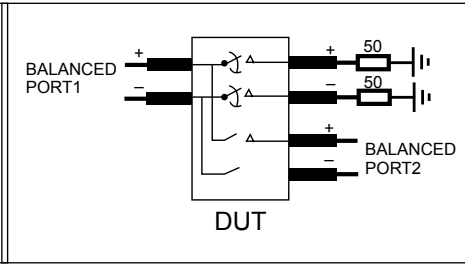

**Diff. Off Isolation Test Circuit**

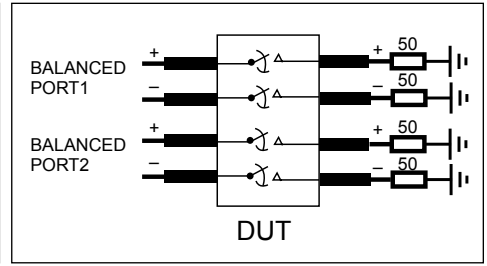

**Diff. Near End Xtalk Test Circuit**

**Test Circuit for Electrical Characteristics<sup>(1-5)</sup>**

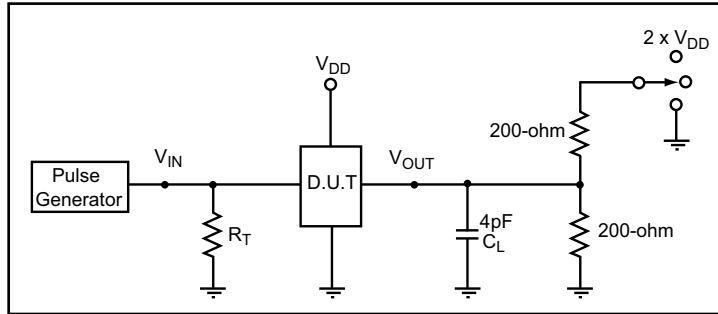

**Notes:**

1.  $C_L$  = Load capacitance: includes jig and probe capacitance.
2.  $R_T$  = Termination resistance: should be equal to  $Z_{OUT}$  of the Pulse Generator
3. Output 1 is for an output with internal conditions such that the output is low except when disabled by the output control.  
output 2 is for an output with internal conditions such that the output is high except when disabled by the output control.
4. All input impulses are supplied by generators having the following characteristics:  $PRR \leq \text{MHz}$ ,  $Z_O = 50\Omega$ ,  $t_R \leq 2.5\text{ns}$ ,  $t_F \leq 2.5\text{ns}$ .
5. The outputs are measured one at a time with one transition per measurement.

**Switch Positions**

Test	Switch
$t_{PLZ}$ , $t_{PZL}$	$2 \times V_{DD}$
$t_{PHZ}$ , $t_{PZH}$	GND
Prop Delay	Open

**Switching Waveforms**

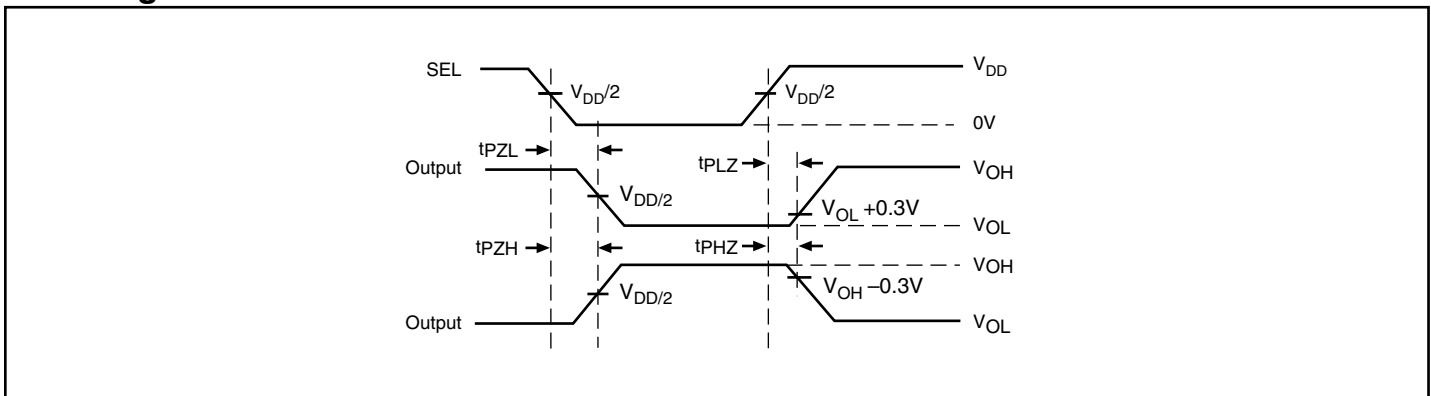

**Voltage Waveforms Enable and Disable Times**

**Package Mechanical: 42-Contact TQFN (ZH)**

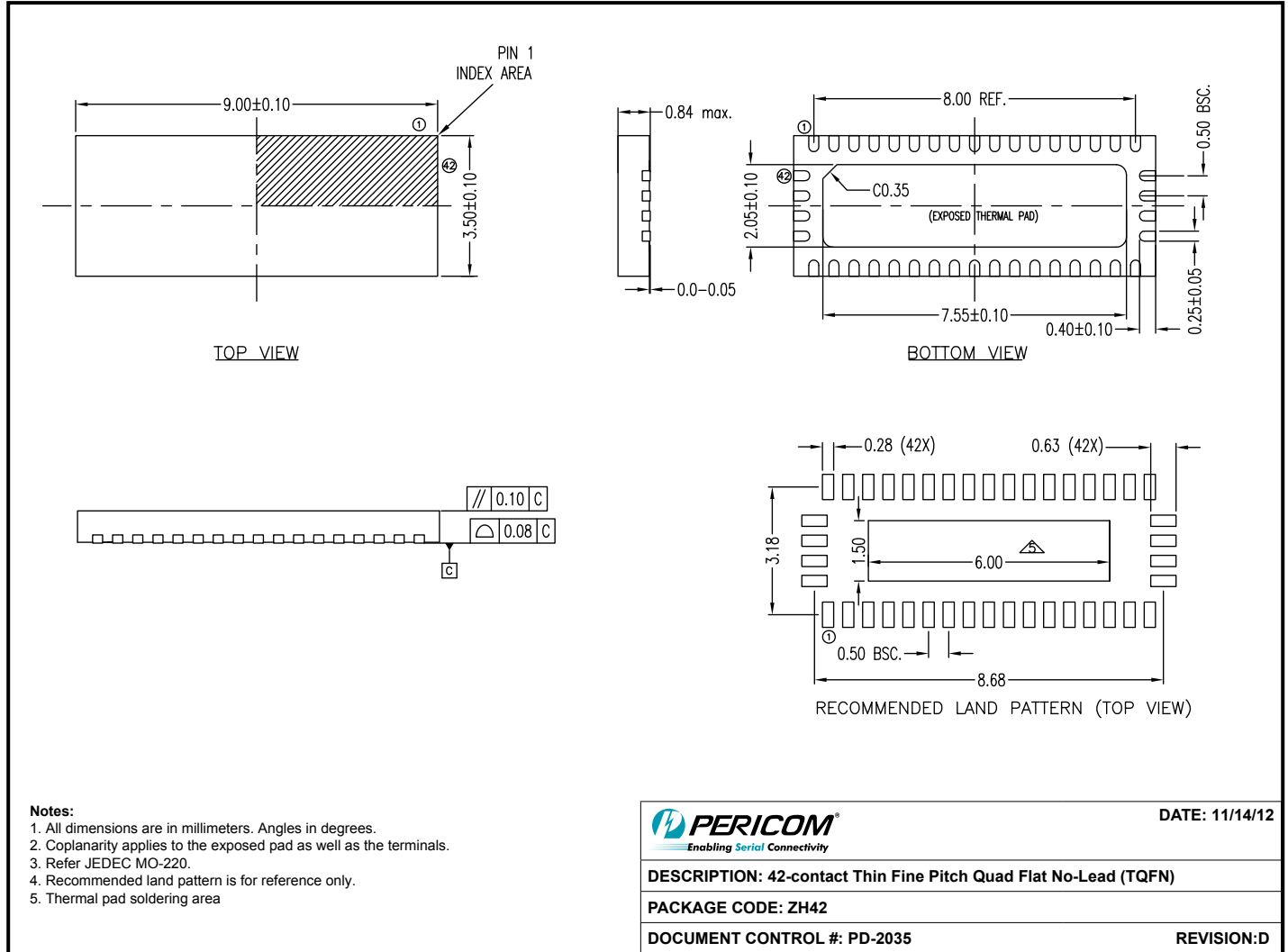

**Ordering Information**

Ordering Code	Package Code	Package Type
PI2PCIE2214ZHEX	ZH	42-Contact, Thin Fine Pitch Quad Flat No-Lead (TQFN)

- Notes:**
- Thermal characteristics can be found on the company web site at [www.pericom.com/packaging/](http://www.pericom.com/packaging/)
  - "E" denotes Pb-free and Green
  - Adding an "X" at the end of the ordering code denotes tape and reel packaging