

Evaluating the **ADP1074** LGA Active Clamp Forward Controller

FEATURES

- Full support evaluation kit for the **ADP1074** LGA package active clamp forward topology
- 5.0 V output voltage
- 12 A rated current
- Programmable light load mode
- Integrated driver for primary side MOSFET and secondary side synchronous rectifier
- External reference signal tracking
- Precision enable UVLO with hysteresis
- Protection features such as short-circuit, output overvoltage, and overtemperature protection
- Cycle by cycle input overcurrent protection
- Frequency synchronization
- Soft start and soft stop functionality

GENERAL DESCRIPTION

The ADP1074LGA-EVALZ evaluation board allows the user to evaluate the **ADP1074** LGA package in a power supply application.

The evaluation board delivers a rated current of 12 A in a steady state from an input voltage range of 9 V dc to 32 V dc.

For full details on the **ADP1074**, refer to the **ADP1074** data sheet. Consult the data sheet when using the ADP1074LGA-EVALZ.

EVALUATION BOARD PHOTOGRAPH



Figure 1.

TABLE OF CONTENTS

Features	1	Gate Signals and Synchronous Rectifier (SR).....	5
General Description	1	Soft Start	5
Evaluation Board Photograph.....	1	Output Ripple	6
Revision History	2	Control Loop.....	6
Evaluation Board Overview	3	Overcurrent Protection	7
Power Train Overview	3	Voltage and Current Stress.....	7
Applications.....	3	Efficiency Curves	8
Connectors	3	Thermal Performance.....	8
Getting Started	4	Evaluation Board Schematics and Artwork.....	9
Caution	4	Schematic.....	9
Hardware	4	Layout	10
Power-Up Procedure.....	4	Bill of Materials.....	12
Evaluating the ADP1074.....	5		

REVISION HISTORY

10/2018—Revision 0: Initial Version

EVALUATION BOARD OVERVIEW

The ADP1074LGA-EVALZ evaluation board features the ADP1074 LGA package in a dc to dc switching power supply with an active clamp forward topology and synchronous rectification operating at a 300 kHz switching frequency.

Figure 2 shows the block diagram of the evaluation board. The circuit provides a rated load of 5.0 V dc, 12 A from a dc input voltage source of 9 V dc to 32 V dc. The ADP1074 LGA package provides features that include output voltage regulation, synchronization, prebias startup, frequency synchronization, and comprehensive protection functions.

POWER TRAIN OVERVIEW

The evaluation board is shown in Figure 1. The evaluation board comes with a fan module and can be plugged into the fan module using the connectors provided. The circuit components are described as follows (see the Evaluation Board Schematics and Artwork section):

- An N channel MOSFET, Q3, is the main switch on the primary side.
- The active clamp reset switch, Q4, and capacitor, C33, are located on the primary side.
- A transformer, T1, provides the isolation.

The secondary side includes an N channel MOSFET, and Q1 and Q6 are the synchronous rectifiers (SRs). The output filter consists of an inductor, L3, and a capacitor bank, C3 to C7 and C9. These components form the main power stage.

Additional circuitry around the power train is also included. The resistor capacitor diode (RCD) snubber for the two

synchronous rectifiers consists of R3, C29, and D4 for one SR, and D3, C30, and R35 for the other SR.

The ADP1074 (U1) is the power controller that controls the power stage. The device integrates a gate drive ability to drive the primary switch and a synchronous rectifier based on Analog Devices, Inc., iCoupler® technology. During startup, U1 is powered by the input via the following external start-up circuit: Transistor Q5, Capacitor C38, R17, and Zener Diode D5. After switching starts, auxiliary windings on Transformer T1 provide power to VREG1. The primary current is sensed using a current sensing resistor, R15.

APPLICATIONS

The high efficiency, high power density, isolated dc to dc power supplies include intermediate bus converters, paralleled power supply systems, power over Ethernet (POE), a server, storage, industrial systems, networking systems, infrastructure systems, and so on.

CONNECTORS

The connections to the evaluation board are shown in Table 1.

Table 1. Evaluation Board Connections

Connector	Function
J2	VIN+, dc Input
J4	VIN-, ground return for the dc input
J1	VOUT+, dc output
J5	VOUT-, return for the dc output

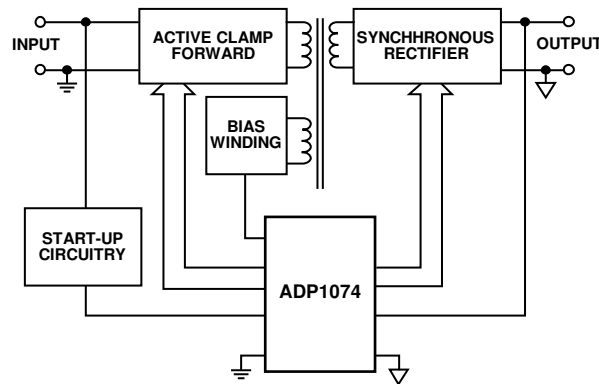

Figure 2. Evaluation Board Block Diagram

Table 2. Evaluation Board Connection Specifications

Parameter	Symbol	Min	Typ	Max	Unit	Test Conditions/Comments
Input Voltage	V_{IN}	9	24	32	V	
Output Voltage	V_{OUT}		5.0		V	
Output Current	I_{OUT}		12		A	
Operating Temperature	T_A		25	60	°C	Natural convection
			25	85	°C	Airflow = 200 linear feet per minute (LFM) or above
Efficiency	η		93.2		%	$V_{IN} = 12\text{ V}, V_{OUT} = 5\text{ V}, I_{OUT} = 8.5\text{ A}$ including fan current
Switching Frequency	f_s		300		kHz	
Output Voltage Ripple			10		mV	$V_{IN} = 12\text{ V}, V_{OUT} = 5.0\text{ V}, I_{OUT} = 12\text{ A}$
Board Size, Length x Width			0.9 x 1.1		Inch	Fits 1/8 th brick module dimensions

GETTING STARTED

CAUTION

This evaluation board uses high voltages. Take extreme caution, especially on the primary side, to ensure user safety. It is strongly recommended to turn off the evaluation board when not in use. A current-limited, isolated dc source is recommended to be used at the input.

HARDWARE

Evaluation Equipment

The evaluation board hardware includes

- A dc power supply capable of 9 V dc to 32 V dc, 15 A.
- An electronic load capable of 150 W, 0 V to 60 V.
- An oscilloscope capable of a 500 MHz bandwidth or above, 2-channel to 4-channel.
- A precision digital multimeter (HP34401 or equivalent).

Evaluation Board Configurations

The evaluation board is preconfigured with default settings to operate the power supply at the rated load. No additional configuration is necessary. Replace J3 with a wire if the primary current must be sensed using a current probe.

POWER-UP PROCEDURE

Use the following procedure to power up the evaluation board:

1. Connect a dc source in the voltage range of 9 V dc to 32 V dc at the input terminals and an electronic load at the output terminals.
2. Connect voltmeters on the input terminals and output terminals separately as needed.
3. Connect the voltage probes at different test pins. Ensure that the differential probes are used and that the ground of the probes is isolated if the measurements are made on the primary side and secondary side of the transformer simultaneously.
4. Set the electronic load to a suitable load less than or equal to 12 A.

After this procedure is complete, the evaluation board is running and ready for evaluation. The output is 5.0 V dc.



Figure 3. ADP1074LGA-EVALZ Evaluation Board, Top Side

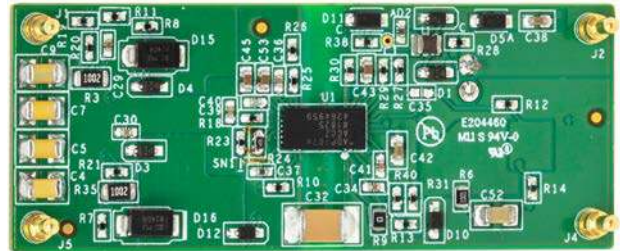

Figure 4. ADP1074 LGA-EVALZ Evaluation Board, Bottom Side

EVALUATING THE ADP1074

Several test points on the evaluation board allow easy monitoring of the various signals. The user can program the operation according to the ADP1074 data sheet. The following sections provide descriptions of the typical features and achievable results when evaluating the ADP1074.

GATE SIGNALS AND SYNCHRONOUS RECTIFIER (SR)

The gate signals (NGATE, PGATE, SR1, and SR2) are generated by isolated gate drivers within the ADP1074. The logic high level is VREG1 for the NGATE and PGATE pins, and VREG2 for SR, while both logic low levels are 0.0 V.

Switching Frequency, Duty Cycle Limit, and Frequency Synchronization

Program the internal oscillator frequency in discrete steps by setting the resistor and using the RT and DMAX pins of the ADP1074. The evaluation board is set up for a nominal frequency of 291 kHz. Program a maximum duty cycle using the DMAX pin. Refer to the ADP1074 data sheet for more information.

Pulse-Width Modulation (PWM) Jitter

Figure 5 shows the typical PWM jitter.

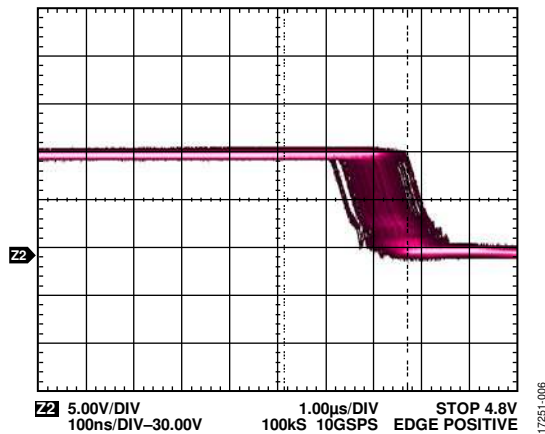

Figure 5. PWM Jitter at a 12 V DC Input, 12 A Load, 200 ns/div

Using an External SYNC Frequency

Remove the resistor on the SYNC pin and synchronize the ADP1074 to an external frequency.

SOFT START

After the voltage at EN exceeds the undervoltage lockout (UVLO) threshold, the converter enters a two-stage soft start sequence, allowing the output voltage to ramp up smoothly. Refer to the ADP1074 data sheet for more information.

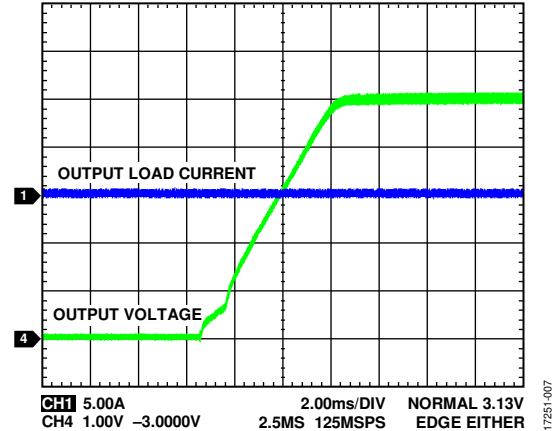

Figure 6. Soft Start at a 12 V DC Input, 0 A Load, 2 ms/div

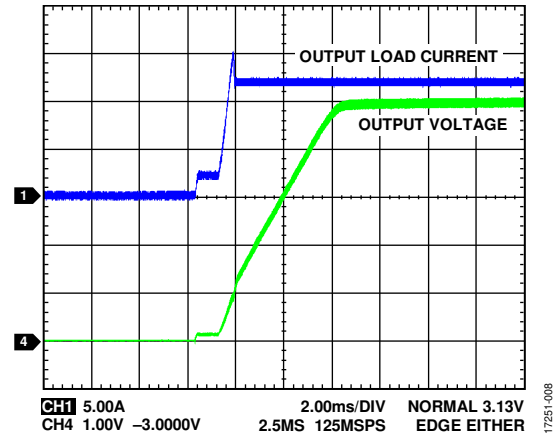

Figure 7. Soft Start at a 12 V DC Input, 12 A Load, 1 ms/div

When soft starting into a precharged output, the soft start scheme prevents the output from being discharged (and prevents reverse current) by tracking SS2 to the FB pin voltage.

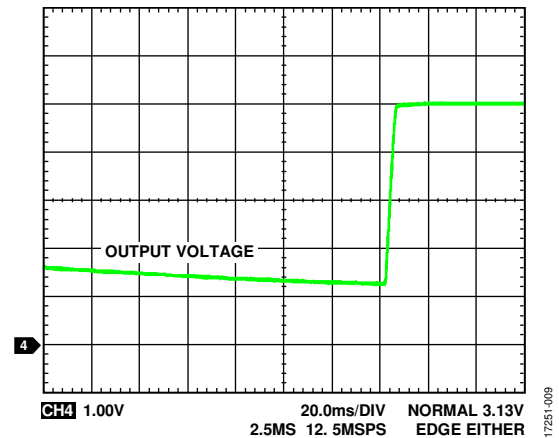

Figure 8. Soft Start from Precharge, 20 ms/div

Changing the Soft Start Slope

Change the slope of the first stage of soft start by changing the SS1 capacitor.

OUTPUT RIPPLE

Output ripple can be measured across C50. Minimize the loop area formed by the probe and the grounding to achieve clean waveforms.

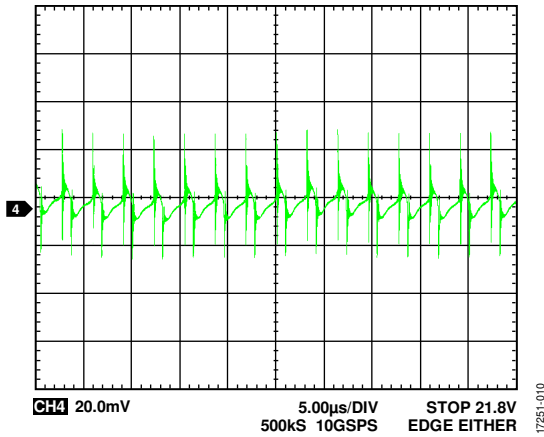

Figure 9. Output Ripple at a 12 V DC Input, No Load, 2 µs/div, Output Voltage AC Coupling

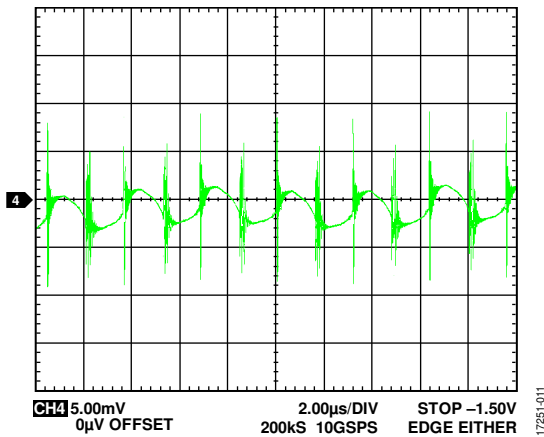

Figure 10. Output Ripple at a 24 V DC Input, 12 A Load, 2 µs/div, Output Voltage AC Coupling

CONTROL LOOP

On the secondary side, the output voltage information is sensed through a voltage divider and sent to the FB pin. The FB pin voltage is compared to a 1.2 V reference signal, and the error determines the COMP voltage. The COMP voltage information is sent to the primary side via the Analog Devices iCoupler technology, allowing closed-loop operation.

The loop gain can be measured using a network analyzer. The small signal perturbation is injected between the output voltage and the TP10 test point. The measurement probes of the network analyzer are connected at the TP10 test point.

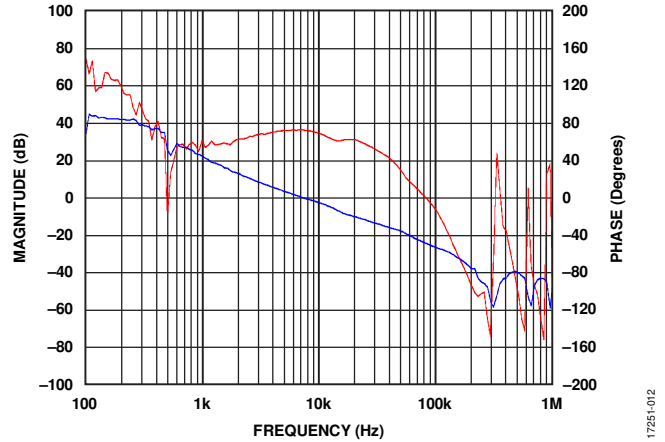

Figure 11. Loop Gain Measurement by the AP200 Loop Analyzer with Nominal Values; 12 V Input, 12 A Load; Crossover Frequency = 7.2 kHz, Phase Margin = 72°, Gain Margin = 24.4 dB

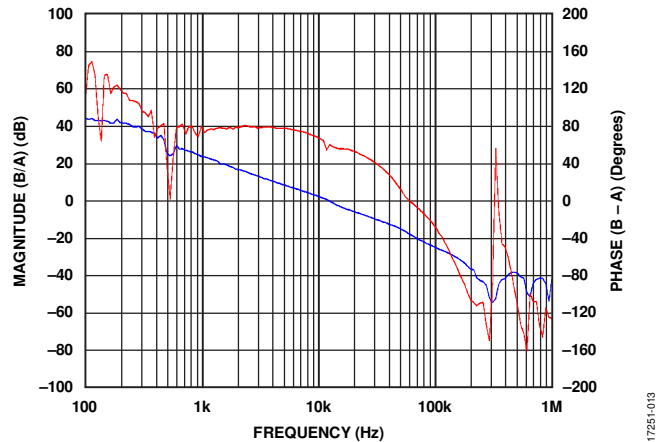

Figure 12. Loop Gain Measurement by the AP200 Loop Analyzer with R18 = 49.9 kΩ; 12 V Input, 12 A Load; Crossover Frequency = 11.79 kHz, Phase Margin = 54.2°, Gain Margin = 17.9 dB

Transient Response for Load Step

A dynamic electronic load can be connected to the output of the evaluation board to evaluate the transient response. Set up an oscilloscope to capture the transient waveform of the power supply output. Figure 13 shows an example of the load transient response.

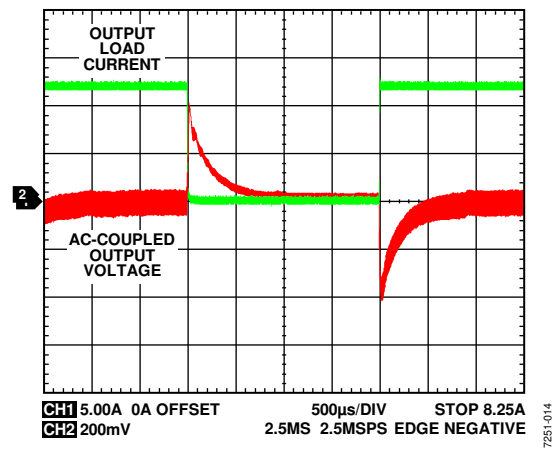

Figure 13. Transient Response with Load Steps from 0% to 100%

OVERCURRENT PROTECTION

The primary peak current is sensed cycle by cycle by a current sensing resistor. When the sensed input peak current is above the CS limit threshold, the controller operates in cycle by cycle constant current-limit mode for 1.25 ms. After 1.25 ms, the controller immediately shuts down the primary drivers and discharges SS2. The controller then goes into shutdown mode for the next 40 ms and then restarts the soft start sequence.

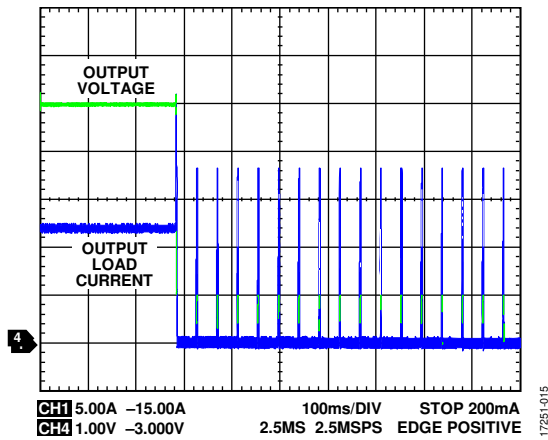

Figure 14. Overcurrent Protection, 100 ms/div

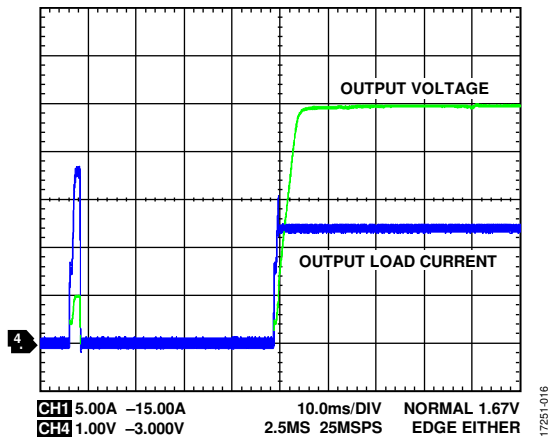

Figure 15. Recovery from Short Circuit, 10 ms/div

VOLTAGE AND CURRENT STRESS

Figure 16 and Figure 17 show the MOSFET drain to source voltage (V_{DS}) at different input voltages.

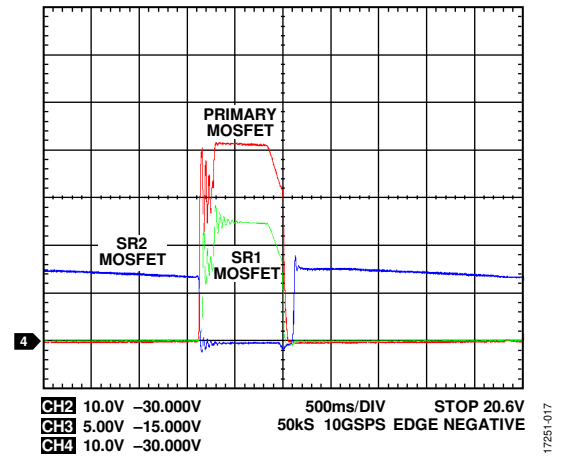

Figure 16. MOSFET Drain to Source Voltages at a 9 V DC Input, 12 A Load, 500 ns/div

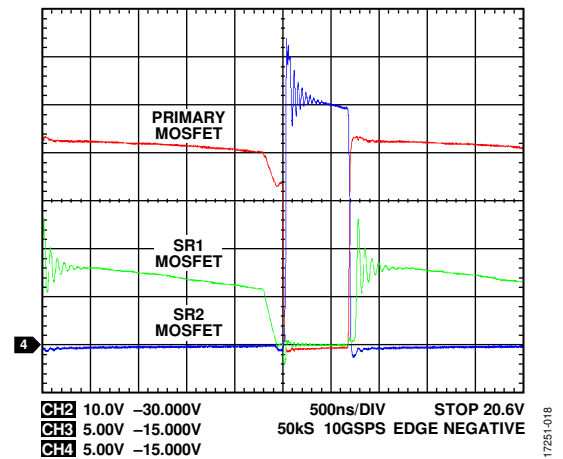

Figure 17. MOSFET Drain to Source Voltages at a 30 V DC Input, 12 A Load, 500 ns/div

EFFICIENCY CURVES

Figure 18 shows an efficiency curve at 48 V dc.

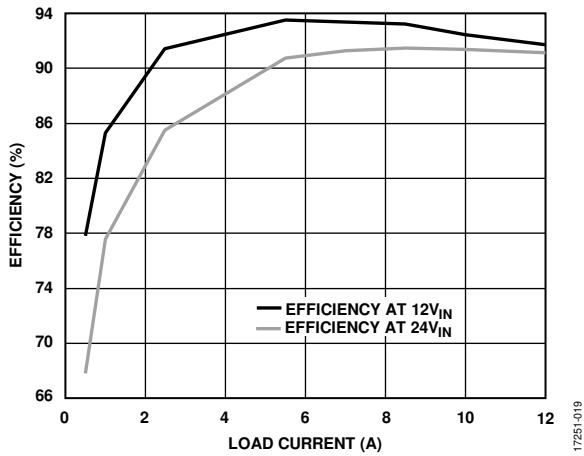

Figure 18. Efficiency Curves

17251-019

THERMAL PERFORMANCE

Figure 19 shows the thermal performance of the ADP1074 under specific conditions, at 12 V dc input, 12 A load with the fan module connected, and 1 hour soaking time.



Figure 19. Thermal Image of the ADP1074 with Air Cooling Provided by Fan, 1 Hour Soaking Time

17251-020

LAYOUT



Figure 21. Board Outline

17251-022

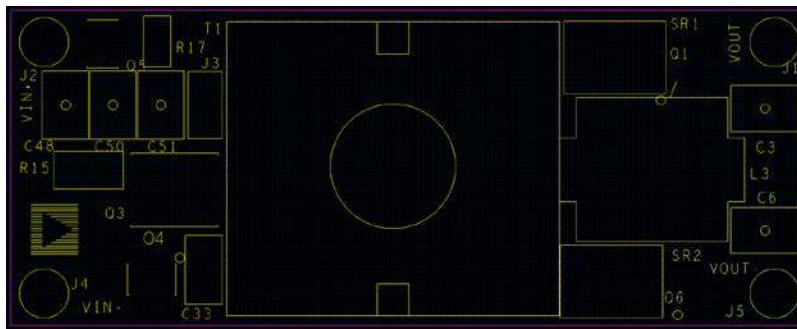

Figure 22. Silkscreen (Top)

17251-023

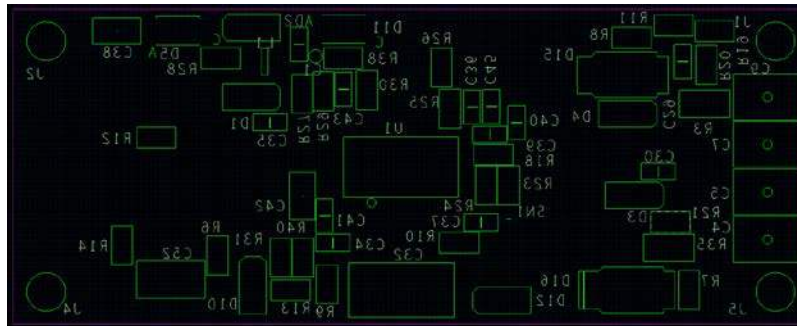

Figure 23. Silkscreen (Bottom)

17251-024

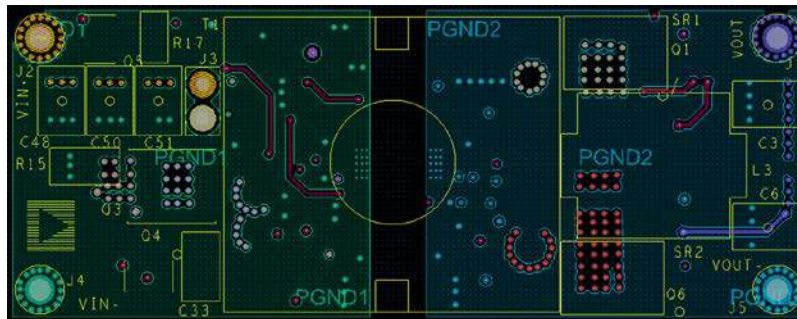
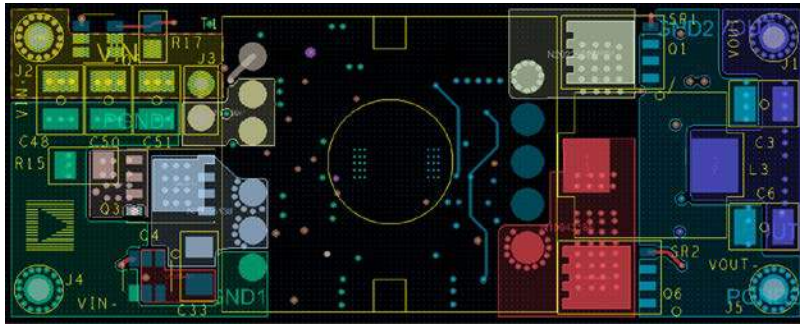

Figure 24. PCB Layout, Top Layer

17251-025



1725-1026

Figure 25. PCB Layout, Layer 2

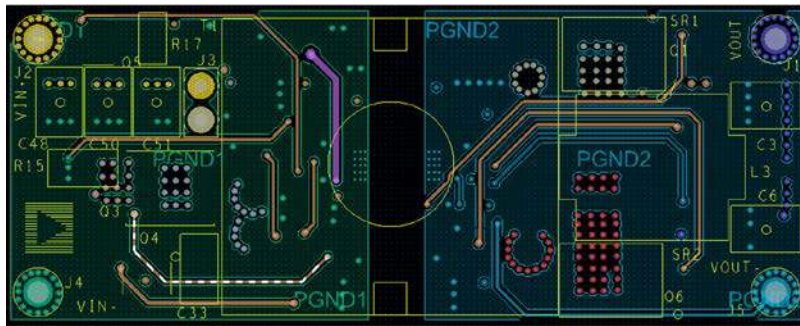

1725-1027

Figure 26. PCB Layout, Layer 3

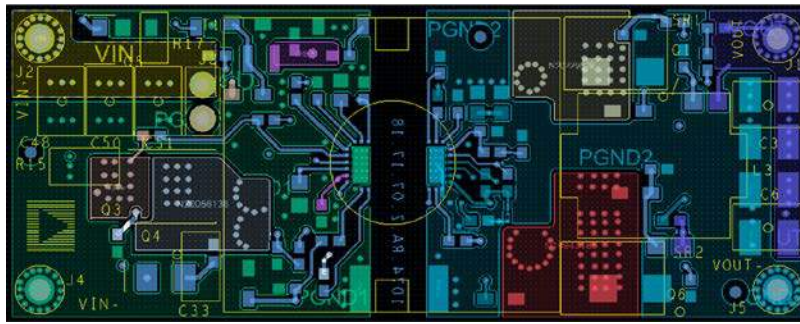

1725-1028

Figure 27. PCB Layout, Layer 4

BILL OF MATERIALS

Table 3 provides the components list for the evaluation board.

Table 3. Evaluation Board Components List

Item	Qty	Value	Reference	Description	Manufacturer	Part Number
1	2	2.2 μ F	C1, C37	2.2 μ F, \pm 20%, 16 V, ceramic capacitor, X5R, 0402	TDK	C1005X5R1C225M050BC
2	6	220 μ F	C3 to C9	Capacitor ceramic, 220 μ F, 6.3 V, X5R, 1206	Murata	GRM31CR60J227ME11 (substitute JMK325ABJ227MM-T)
3	2	0.01 μ F	C29, C30	50 V, ceramic capacitor, X7R, 0402	Murata	GCM155R71H103KA55D (substitute CGA2B3X5R1H103K050BB)
4	1	2200 pF	C32	Capacitor, ceramic, 2200 pF, 2 kV, X7R, 1812	Vishay	C4532X7R3D222K130KA
5	1	0.22 μ F	C33	Capacitor, ceramic, 0.22 μ F, 100 V, X7R, 1206	TDK	C3216X7R2A224K115AA
6	3	0.1 μ F	C34, C36, C41	Capacitor, ceramic, 0.1 μ F, 35 V, X7R, 0402	TDK	CGA2B3X7R1V104K050BB (substitute C1005X7R1H104K050BB)
7		Do not insert	C35	Do not install (TBD_C0402)	TBD0402	E000381
8	2	2.2 μ F	C38, C42	Capacitor, ceramic, 2.2 μ F, 35 V, X5R, 0603	Murata	GRT188R6YA225ME13D
9	1	100 pF	C39	Capacitor, ceramic, 100 pF, 50 V, C0G/NP0, 0402	Murata	GRM1555C1H101JA01D (substitute 04025C101KAT2A)
10	1	4700 pF	C40	Capacitor, ceramic 4700 pF 50 V X7R 0402	Kemet	UMK105B7472KV-F (substitute 500R07W472KV4T)
11	3	1.5 μ F	C43, C45, C53	Capacitor, ceramic, 1.5 μ F, 35 V, X5R, 0603	TDK	C1608X5R1V155M080AC
12	3	2.2 μ F	C48, C50, C51	Capacitor, ceramic, 2.2 μ F, 100 V, X7R, 1210	AVX	12101C225KAZ2A
13	1	0.1 μ F	C52	Capacitor, ceramic, 0.1 μ F, 250 V, X7R, 1206	Murata	GRM31CR72E104KW03L
14	6	1N4148WX	D1 to D4, D10, D12	Diode, small signal	Infineon	1N4148WX
15	2	B240A-13-F	D15, D16	Diode, 1 A, Schottky	Diodes, Inc.	B240A-13-F
16	2	Zener	D5, D11	Diode, Zener, 11 V, 500 mW, SOD123	Diode, Inc.	BZT52C11-7-F
17	4	VOUT+, VIN+, VIN-, VOUT-	J1, J2, J4, J5	Connector, PC pin, 0.062 inch diameter, gold	Mill-Max Manufacturing Corp.	6035-0-00-15-00-00-03-0
18	1	Not applicable	J3	Short with thick wire	Not applicable	Not applicable
19	1	1000 μ H	L1	Fixed inductor, 1 mH, 75 mA, 31.2 Ω , surface-mount device (SMD)	Taiyo Yuden	CB2518T102K
20	1	2 μ H	L2	2 μ H, 16 A inductor	Vishay	IHLP4040DZER2R0M11 (substitute 74439369022)
21	2	BSC014N04LSI	Q1, Q6	MOSFET, N channel, 40 V, 100 A, TDSON-8	Infineon	BSC014N04LSI
22	1	FDMS039N08	Q3	Transistor, MOSFET N channel, 80 V, 3.2 m Ω	On Semi	TPH1R306PL (substitute SIR680DP-T1-RE3)
23	1	ZXMP6A17E6TA	Q4	P channel, MOSFET, 60 V	Diodes, Inc.	ZXMP6A17E6TA
24	1	FMBS2383	Q5	Transistor, NPN, 160 V, 0.8 A, 6-SSOT	Fairchild	FMBS2383
25	2	10 k Ω	R3, R35	SMD resistor, 10 k Ω , 1 W, 5%	Vishay Dale or equivalent	CRCW120610K0FKEAC
26	1	1 k Ω	R6	SMD resistor, 1 k Ω , 1/8 W, 1%	Vishay Dale or equivalent	CRCW08051K00FKEAC
27	1	0 Ω	R9	SMD resistor, 0 Ω , 1/8 W, jumper	YAGEO	RC0805JR-070RL

Item	Qty	Value	Reference	Description	Manufacturer	Part Number
28	5	10 k Ω	R7, R8, R13, R14, R25, R10, R11	SMD resistor, 10 k Ω , 1/8 W, 1%	Vishay Dale or equivalent	CRCW040210K0FKEDC
29	2	0 Ω	R10, R11	SMD resistor 0 Ω , 1/8 W, jumper	Vishay Dale or equivalent	CRCW040210K0FKEDC
30	1	1.5 k Ω	R12	SMD resistor, 1.5 k Ω , 1%, 1/16 W, 0402	Vishay Dale or equivalent	CRCW04021K50FKEDHP
31	1	8 m Ω	R15	Current sense resistor, 8 m Ω , 1%	Vishay Dale or equivalent	ERJ-MP2KF8M0U
32	1	10 k Ω	R17	Resistor, film, SMD, 0805	Vishay Dale or equivalent	CRCW080510K0FKEA
33	1	24.9 k Ω	R18	Resistor, SMD, 24.9 k Ω , 1%, 1/10 W, 0402	Vishay Dale or equivalent	CRCW040224K9FKED
34	1	10 Ω	R19	Resistor, SMD, 10 Ω , 1%, 1/10 W, 0402	Vishay Dale or equivalent	ERJ-2RKF10R0X
35	2	3.09 k Ω	R20, R21	Resistor, SMD, 3.09 k Ω , 1%, 1/10 W, 0402	Vishay Dale or equivalent	CRCW04023K09FKED
36	1	976 Ω	R23	Resistor, SMD, 976 Ω , 1%, 1/10 W 0402	Vishay Dale or equivalent	CRCW0402976RFKED
37	1	887 Ω	R24	Resistor, SMD, 887 Ω , 1%, 1/10 W 0402	Vishay Dale or equivalent	
38	2	0 Ω	R26, R29	SMD, resistor, 0 Ω , 1/8 W, jumper	Vishay Dale or equivalent	CRCW040210K0FKEDC
39	1	28.1 k Ω	R27	Resistor, SMD, 28.1 k Ω , 1%, 1/16 W, 0402	Vishay Dale or equivalent	CRCW040228K0FKED
40	1	49.9 k Ω	R30	Resistor, SMD, 49.9 k Ω , 1%, 1/16 W, 0402	Vishay Dale or equivalent	CRCW040249K9FKEDC
41	1	24.3 k Ω	R28	Resistor, SMD, 24.3 k Ω , 1%, 1/16 W, 0402	Vishay Dale or equivalent	CRCW040224K3FKED
42	1	6.2 k Ω	R31	Resistor, SMD, 6.2 k Ω , 1%, 1/16 W, 0402	Vishay Dale or equivalent	CRCW04026K20FKED
43	1	100 Ω	R38	Resistor, SMD, 100 Ω , 1%, 1/10 W, 0402	Vishay Dale or equivalent	CRCW0402100RFKED
44	1	169 k Ω	R40	Resistor, SMD, 169 k Ω , 1%, 1/10 W, 0402	Vishay Dale or equivalent	CRCW0402169KFKED
45	1	PL160X9-102L	T1	Transformer	Coilcraft	PL160X9-102L
46	1	ADP1074	U1	ADP1074 LGA package	Analog Devices	ADP1074ACCZ

NOTES

**ESD Caution**

ESD (electrostatic discharge) sensitive device. Charged devices and circuit boards can discharge without detection. Although this product features patented or proprietary protection circuitry, damage may occur on devices subjected to high energy ESD. Therefore, proper ESD precautions should be taken to avoid performance degradation or loss of functionality.

Legal Terms and Conditions

By using the evaluation board discussed herein (together with any tools, components documentation or support materials, the "Evaluation Board"), you are agreeing to be bound by the terms and conditions set forth below ("Agreement") unless you have purchased the Evaluation Board, in which case the Analog Devices Standard Terms and Conditions of Sale shall govern. Do not use the Evaluation Board until you have read and agreed to the Agreement. Your use of the Evaluation Board shall signify your acceptance of the Agreement. This Agreement is made by and between you ("Customer") and Analog Devices, Inc. ("ADI"), with its principal place of business at One Technology Way, Norwood, MA 02062, USA. Subject to the terms and conditions of the Agreement, ADI hereby grants to Customer a free, limited, personal, temporary, non-exclusive, non-sublicensable, non-transferable license to use the Evaluation Board FOR EVALUATION PURPOSES ONLY. Customer understands and agrees that the Evaluation Board is provided for the sole and exclusive purpose referenced above, and agrees not to use the Evaluation Board for any other purpose. Furthermore, the license granted is expressly made subject to the following additional limitations: Customer shall not (i) rent, lease, display, sell, transfer, assign, sublicense, or distribute the Evaluation Board; and (ii) permit any Third Party to access the Evaluation Board. As used herein, the term "Third Party" includes any entity other than ADI, Customer, their employees, affiliates and in-house consultants. The Evaluation Board is NOT sold to Customer; all rights not expressly granted herein, including ownership of the Evaluation Board, are reserved by ADI. CONFIDENTIALITY. This Agreement and the Evaluation Board shall all be considered the confidential and proprietary information of ADI. Customer may not disclose or transfer any portion of the Evaluation Board to any other party for any reason. Upon discontinuation of use of the Evaluation Board or termination of this Agreement, Customer agrees to promptly return the Evaluation Board to ADI. ADDITIONAL RESTRICTIONS. Customer may not disassemble, decompile or reverse engineer chips on the Evaluation Board. Customer shall inform ADI of any occurred damages or any modifications or alterations it makes to the Evaluation Board, including but not limited to soldering or any other activity that affects the material content of the Evaluation Board. Modifications to the Evaluation Board must comply with applicable law, including but not limited to the RoHS Directive. TERMINATION. ADI may terminate this Agreement at any time upon giving written notice to Customer. Customer agrees to return to ADI the Evaluation Board at that time. LIMITATION OF LIABILITY. THE EVALUATION BOARD PROVIDED HEREUNDER IS PROVIDED "AS IS" AND ADI MAKES NO WARRANTIES OR REPRESENTATIONS OF ANY KIND WITH RESPECT TO IT. ADI SPECIFICALLY DISCLAIMS ANY REPRESENTATIONS, ENDORSEMENTS, GUARANTEES, OR WARRANTIES, EXPRESS OR IMPLIED, RELATED TO THE EVALUATION BOARD INCLUDING, BUT NOT LIMITED TO, THE IMPLIED WARRANTY OF MERCHANTABILITY, TITLE, FITNESS FOR A PARTICULAR PURPOSE OR NON-INFRINGEMENT OF INTELLECTUAL PROPERTY RIGHTS. IN NO EVENT WILL ADI AND ITS LICENSORS BE LIABLE FOR ANY INCIDENTAL, SPECIAL, INDIRECT, OR CONSEQUENTIAL DAMAGES RESULTING FROM CUSTOMER'S POSSESSION OR USE OF THE EVALUATION BOARD, INCLUDING BUT NOT LIMITED TO LOST PROFITS, DELAY COSTS, LABOR COSTS OR LOSS OF GOODWILL. ADI'S TOTAL LIABILITY FROM ANY AND ALL CAUSES SHALL BE LIMITED TO THE AMOUNT OF ONE HUNDRED US DOLLARS (\$100.00). EXPORT. Customer agrees that it will not directly or indirectly export the Evaluation Board to another country, and that it will comply with all applicable United States federal laws and regulations relating to exports. GOVERNING LAW. This Agreement shall be governed by and construed in accordance with the substantive laws of the Commonwealth of Massachusetts (excluding conflict of law rules). Any legal action regarding this Agreement will be heard in the state or federal courts having jurisdiction in Suffolk County, Massachusetts, and Customer hereby submits to the personal jurisdiction and venue of such courts. The United Nations Convention on Contracts for the International Sale of Goods shall not apply to this Agreement and is expressly disclaimed.