

PANDUIT PART NUMBER	STUD SIZE	DIMENSIONS in.				
		A ±.04	W ±.01	C ±.02	M ±.04	H ±.01
PN10-6F	#6	1.00 (25.40)	.31 (7.87)	.22 (5.59)	.81 (20.57)	.15 (3.81)
PN10-8F	#8	1.03 (26.16)	.37 (9.40)	.22 (5.59)	.81 (20.57)	.17 (4.32)
PN10-10F	#10	1.04 (26.42)	.37 (9.40)	.22 (5.59)	.81 (20.57)	.20 (5.08)
PN10-14F	1/4"	1.14 (28.96)	.49 (12.45)	.30 (7.62)	.90 (22.86)	.27 (6.86)

NOTES:

- UL LISTED AND CSA CERTIFIED FOR:
 - 600V. MAX. BLDG WIRE (1000 V. MAX IN SIGNS, FIXTURES & LUMINARIES)
 - #14-10 AWG SOLID OR STRANDED COPPER WIRE WITH THE CT-550 INSTALLATION TOOL.
 - #12-10 AWG STRANDED AND #12 AWG SOLID COPPER WIRE WITH THE CT-1550 AND CT-1551 INSTALLATION TOOLS.
 - #12-10 AWG SOLID OR STRANDED COPPER WIRE WITH THE CT-100 INSTALLATION TOOL.
 - 221°F (105°C) MAX TEMP. RATING
- MATERIAL:
 - STAMPING - .04" (1.02) THK COPPER, TIN PLATED
 - HOUSING - NYLON, YELLOW
 - SLEEVE - BRASS, TIN PLATED
- STRIP LENGTH - $9/32 +^{1/32}_{-0}$
- SEE www.panduit.com FOR PART NUMBER SUFFIX DESIGNATION FOR PACKAGE SIZE.
- DIMENSIONS IN BRACKETS ARE IN MILLIMETERS

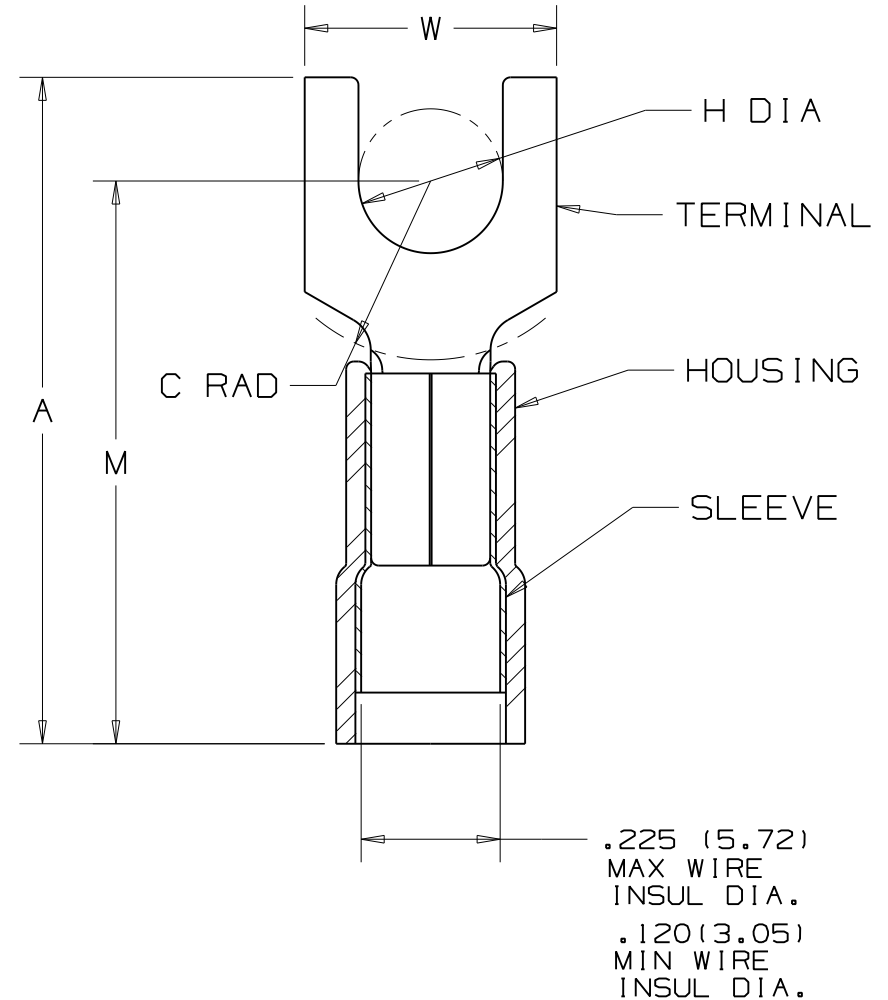

LISTED
587H
E52164



CERTIFIED
LR31212

								PANDUIT CORP.		TINLEY PARK, ILLINOIS	
								3PC. NYLON INSULATED, 12-10 BARREL, FORKS			
05	5/11	SB	UPDATED NOTE #4								
REV	DATE	BY	CHK	DESCRIPTION	ECN #	CUST	PM	DRAWN BY FES	CHK'D LA	SCALE NONE	DRAWING NO. A41190